

CHAPTER 2

INTRODUCTION TO TRANSACTION PROCESSING

REVIEW QUESTIONS

1. The expenditure cycle, conversion cycle, and revenue cycle.
2. Purchases/accounts payable system, cash disbursements system, fixed assets system, and payroll system.
3. The physical component includes the acquisition of goods, while the financial component includes the recognition of a liability owed to the supplier and the transfer of the payment to the supplier.
4. Production system and cost accounting system.
5. Sales order processing system and cash receipts system.
6. Source documents, product documents, and turnaround documents.
7. Special journals and the general journal.
8. A general journal is used to record nonrecurring and infrequent transactions. Oftentimes, general journals are replaced with a journal voucher system. The journal voucher is used to record a single nonrecurring and infrequent transaction, and it is used as a special source document for the transaction. The total of journal vouchers processed is equivalent to the general journal.
9. General ledger and subsidiary ledger.
10. A trail that allows the auditor to begin with a summary total found on the financial statements and track it back to the individual transactions that make

up this total. Conversely, an auditor should be able to track transactions to their final impact on the financial statements.

11. The confirmation process entails selecting customers and contacting them to determine whether the transactions recorded in the financial statements actually took place and are valid.
12. Master files, transaction files, reference files, and archive files.
13. Master files correspond to general ledger accounts and subsidiary ledgers. Examples include accounts receivable and customer subsidiary accounts, accounts payable and vendor subsidiary accounts, inventory, etc. Transaction files correspond to general and special journals. Examples include the general journal, sales journals, cash receipts journals, payroll journals, etc. Reference files include lists of vendors, delinquent customers, tax tables, sales tax rates, discount rates, lists of customers granted specific discounts, etc. Archive files are typically composed of records that have been processed but are retained for their history. Examples include payroll transactions, sales transactions, etc.
14. The digital audit trail, like the paper trail, allows us to trace transactions from the financial statement balance back to the actual transaction so we may: (1) compare balances, (2) perform reconciliations, (3) select and trace samples of entries, and (4) identify, pull, and verify specific transactions.
15. Cardinality reflects normal business rules as well as organizational policy. For instance, the 1:1 cardinality in the first example in Figure 2-16 suggests that each salesperson in the organization is assigned one automobile. If instead

the organization's policy were to assign a single automobile to one or more salespeople that share it, this policy would be reflected by a 1:M relationship.

16. Entity relationship diagrams represent the relationship between entities (resources, events, and agents) in a system. Dataflow diagrams represent the logical elements (i.e. what is being done) of a system by illustrating processes, data sources, data flows, and entities. System flowcharts represent the physical elements being used (i.e., how the tasks are being conducted) by illustrating the relationship between input sources, program, and output products. System flowcharts can also represent both the logical and physical elements of manual systems and also illustrate the preparation and handling of documents.
17. Cardinality refers to the numerical mapping between entity instances, and it is a matter of organization policy. The relationship can be one-to-one, one-to-many, or many-to-many.
18. An entity relationship (ER) diagram is a documentation technique used to represent the relationship between entities. One common use for ER diagrams is to model an organization's database, which we examine in detail in Chapter 9.
19. Entities are physical resources (automobiles, cash, or inventory), events (ordering inventory, receiving cash, shipping goods), and agents (salesperson, customer, or vendor) about which the organization wishes to capture data.

20. Batch processing occurs when similar transactions are accumulated over time and processed together. Real-time processing captures each event or transaction and processes it before engaging in another transaction. If transactions are independent of one another, such as the processing of daily cash receipts, then batch processing is appropriate. If transactions are dependent on one another, such as credit sales, ticket sales, etc., then real-time processing is more appropriate.
21. A flat-file model is one in which individual data files are not related to other files. End users in this environment own their data files rather than share them with other users. Data processing is thus performed by standalone applications rather than integrated systems.
22. No. A DFD shows which tasks are being performed, but not who performs them. It depicts the logical system.
23. Yes, A flowchart depicts the physical system and illustrates what type of and where a task is performed and who is performing it.
24. A single transaction may affect several different accounts. Some of these accounts, however, may not need to be updated in real time. In fact, the task of doing so takes time which, when multiplied by hundreds or thousands of transactions, can cause significant processing delays. Batch processing of non-critical accounts, however, improves operational efficiency by eliminating unnecessary activities at critical points in the process.
25. When testing an application program, the auditor needs details about its

internal logic provided by the program flowchart to design the audit tests.

26. The system flowchart shows the relationship between two computer programs, the files that they use, and the outputs that they produce. However, this level of documentation does not provide the operational details that are sometimes needed. An auditor wishing to assess the correctness of a program's logic cannot do so from the system flowchart. A program flowchart provides this detail. Every program represented in a system flowchart should have a supporting program flowchart that describes its logic.
27.
 - a. increased data storage since the same data is stored in multiple files
 - b. increased data updating since changes must be made to multiple files
 - c. possibility of noncurrent data caused by failure to update.
28. Another problem with the flat-file approach is the user's inability to obtain additional information as his or her needs change. This problem is called task-data dependency. The user's information set is constrained by the data that he or she possesses and controls. Users act independently rather than as members of a user community. In such an environment, it is difficult to establish a mechanism for the formal sharing of data. Therefore, new information needs tend to be satisfied by procuring new data files. This takes time, inhibits performance, adds to data redundancy, and drives data management costs even higher.
29. Organizations have overcome some of the problems associated with flat files by implementing the database model to data management. Figure 2-13 illustrates how this approach centralizes the organization's data into a

common database that is shared by other users. With the organization's data in a central location, all users have access to the data they need to achieve their respective objectives. Access to the data resource is controlled by a database management system (DBMS).

30. Record layout diagrams are used to reveal the internal structure of the records that constitute a file or database table. The layout diagram usually shows the name, data type, and length of each attribute (or field) in the record.
31. Updating a master file record involves changing the value of one or more of its variable fields to reflect the effects of a transaction.
32. The DBMS is a special software system that permits users to access authorized data only. The user's application program sends requests for data to the DBMS, which validates and authorizes access to the database in accordance with the user's level of authority. If the user requests data that he or she is not authorized to access, the request is denied.
33. The flat-file approach is a single-view model. Files are structured, formatted, and arranged to suit the specific needs of the owner or primary user of the data. Such structuring, however, may exclude data needed by other users, thus preventing successful integration of data across the organization.
34. Transaction volume is the key factor. Large-scale systems that process high volumes of transactions often use real-time data collection and batch updating. Master file records that are unique to a transaction such as customer accounts and individual inventory records can be updated in real

time without causing operational delays. Common accounts should be updated in batch mode. Real-time processing is better suited to systems that process lower transaction volumes and those that do not share common records.

35. In a real-time processing environment, the master files are updated as soon as the transaction is submitted and accepted into the system. Thus, reports are more accurate in the sense that the information is as current as possible. Faster operational response time to customer requests such as the shipping of an order is another, and very important, benefit. Finally, the reduction of paper and storage space of physical source documents is another benefit.
36. By collecting data in real time, certain transaction errors can be prevented or detected and corrected at their source.
37. Block codes for the general ledger accounts, sequential codes for documents, and group codes for coding transactions.
38. Sequential codes are appropriate for items in either an ascending or descending sequence, such as the numbering of checks or source documents. An advantage is that during batch processing, any gaps detected in the sequence is a signal that a transaction may be missing. A disadvantage is that the codes carry little, if any, information other than the sequence order. Another disadvantage is that sequential codes are difficult to manage when items need to be added; the sequence needs either to be reordered or the items must be added to the end of the list. Block codes provide some remedies to sequential codes by restricting each class to a prespecified

range. The first digit typically represents a class, whereas the following digits are sequential items which may be spaced in intervals in case of future additions. An example of block coding is a chart of accounts. A disadvantage of block coding is that the information content does not provide much meaning, i.e. an account number only means something if the chart of accounts is known. Group codes may be used to represent complex items or events involving two or more pieces of related data. The code is comprised of fields which possess specific meaning. The advantages of group codes over sequential and block codes are 1. they facilitate the representation of large amounts of diverse data, 2. they allow complex data structures to be represented in a hierarchical form that is logical and thus more easily remembered by humans, and 3. they permit detailed analysis and reporting both within an item class and across different classes of items. A disadvantage is that the codes may be overused to link classes which do not need to be linked, and thus create a more complex coding system than is necessary. Alphabetic codes may be used sequentially or in block or group codes. An advantage is that a system which uses alphabetic codes can represent far more situations than a system with numeric codes given a specific field size. Some disadvantages are that sequentially assigned codes mostly have little meaning. Also, humans typically find alphabetic codes more difficult to sort than numeric data. Lastly, mnemonic codes are alphabetic characters in the form of acronyms, abbreviations or other combinations that convey meaning. The meaning aspect is its advantage. A disadvantage of

mnemonic codes is that they are limited in their ability to represent items within a class (i.e. names of all of American Express's customers).

DISCUSSION QUESTIONS

1. Cash flows into the firm from sales made to customers. The sales order processing subsystem of the revenue cycle captures the intent of customers to exchange cash for services or goods manufactured. Typically sales are made on credit. The cash receipts subsystem of the revenue cycle captures the actual receipt of cash. Depending on the credit terms and promptness of payment by the customer, the lag between the sales order processing subsystem and the cash receipts subsystem may be days, weeks, or months.

The cash inflow allows the organization to purchase raw materials, pay workers, and buy capital assets necessary to manufacture the product (or to provide services). The raw materials requirements are determined by the production planning subsystem of the conversion cycle. These requirements trigger orders being placed through the purchases/accounts payable subsystem of the expenditure cycle. For credit sales, the cash is ultimately released once the goods are received (or services are performed) and an invoice has been received. The lag between receiving goods and disbursement of cash may be days or weeks. Cash is also disbursed to employees, typically after services are rendered by the employees. The lag is usually no more than one-half a month for salaried

employees and as short as one-half a week for hourly wage earners. The payroll subsystem of the expenditure system captures these disbursements to employees.

2. Initially, the cost accounting system was used for the valuation of inventory and cost of goods sold reported to external users; however, the valuable use of cost accounting data for budgeting, cost control, performance reporting, and management decision making have proved to be crucial internal support.
3. The conversion cycle activities for service and retailing entities include planning the items to purchase or the services to produce, planning the workforce to accomplish the necessary tasks (extremely crucial in service entities), and directing the workforce in performing the service or selling the good.
4. Yes. For example, the remittance advice of a bill that is returned with the payment serves as a source document for the cash receipts transaction processing system. Thus, the product document becomes a source document.
5. This type of transaction is recorded in the general journal since it is nonrecurring, infrequent, and not similar to other types of transactions.
6. Sometimes the terms are used interchangeably, such as the sales journal is sometimes called the sales register. The term journal is appropriate when the information needs to be ultimately posted to the general ledger. Registers may be used to keep logs of information that may support, but do not specifically get posted to the general ledger, such as a raw materials receipts register or a

shipping log.

7. The balance in the general ledger is considered a control account. This amount is an aggregated number representing the total amount owed to creditors listed in the accounts payable journal. The accounts payable subsidiary ledger details the exact amount owed to each creditor. The sum of the amounts owed to each creditor listed in the accounts payable journal should equal the corresponding control total in the general ledger. Thus, the accounts payable subsidiary ledger is a detailed breakdown of the summary control total of accounts payable in the general ledger.
8. Confirmation is most typically used for confirming the accounts receivable account as reported on the balance sheet. The audit trail is used to trace from the general ledger accounts receivable control account to the subsidiary account, and then to specific customer accounts. A sample of the customer accounts is then selected for confirmation.
9. In theory, the digital audit trail functions the same as a manual audit trail. In practice, the steps are slightly different. The archive file that consists solely of valid transactions is the file to which the accounts receivable subsidiary account balances and transactions are traced. The customers still need to be contacted for confirmation.
10. Small batches have the advantage of fewer transactions to sort through for error detection, but they are not processed as efficiently. Further, computing facilities and constraints might dictate whether multiple small batches may be processed throughout the day or whether a single large batch is processed at

night when the computing facilities have excess capacity. (Multiple small batches may still be processed in the evening.)

11. Not all modern organizations use entirely modern information systems. Some firms employ legacy systems for certain aspects of their data processing. When legacy systems are used to process financially significant transactions, auditors need to know how to evaluate and test them.
12. Large-scale systems that process high volumes of transactions often use real-time data collection and batch updating. Master file records that are unique to a transaction, such as customer accounts and individual inventory records, can be updated in real time without causing operational delays. Common accounts should be updated in batch mode. Real-time processing is better suited to systems that process lower transaction volumes and those that do not share common records.
13. Real-time processing is better suited to systems that process lower transaction volumes and those that do not share common records.
14. The most striking difference between the database model and the flat-file model is the pooling of data into a common database that all organizational users share.
15. The flat-file approach is a single-view model. Files are structured, formatted, and arranged to suit the specific needs of the owner or primary user of the data. Such structuring, however, may exclude data needed by other users, thus preventing successful integration of data across the organization. For

example, because the accounting function is the primary user of accounting data, these data are often captured, formatted, and stored to accommodate financial reporting and generally accepted accounting principles(GAAP). This structure, however, may be useless to the organization's other (nonaccounting) users of accounting data such as the marketing, finance, production, and engineering functions. These users are presented with three options: (1) do not use accounting data to support decisions, (2) manipulate and massage the existing data structure to suit their unique needs, or (3) obtain additional private sets of the data and incur the costs and operational problems associated with data redundancy.

16. The data update problem in a flat-file model occurs because organizations have a great deal of data stored in files that require periodic updating to reflect changes. For example, a change to a customer's name or address must be reflected in the appropriate master files. When users keep separate files, all changes must be made separately for each user. This adds significantly to the task and the cost of data management.

Information currency problems occur because user failing to update all the user files affected by a change in status. If update information is not properly disseminated, the change will not be reflected in some users' data, resulting in decisions based on outdated information.

17. The auditor should examine the system flowchart since it clearly depicts the separation of functions and illustrates who is responsible for performing specific processing steps. The dataflow diagram illustrates the logical system

and is too general since many different physical designs may be applicable.

18. Uncoded data takes a great deal of recording space, is time-consuming to record and is prone to many types of errors. Consider a firm that manufactures bicycles and carries in its inventory reflector lights. The lights come in six sizes, 2 colors, and 4 different grades of material. Thus, 48 different varieties of reflector light are held (6x2x4). Every time lights are purchased, the description would need to be included rather than a code. For example if 100 units of one type of reflector light were purchased, and 200 units of another were purchased from Collins Manufacturer in Roanoke, Virginia, the journal entry would be:

Inventory-2", yellow, metal reflector light	75
Inventory-3", orange, plastic reflector light	120
A/P-Collins Mnf-Roanoke, VA	195

Some problems this approach may produce are 1. the sales staff will have a more tedious job in writing up orders, and more errors may occur (i.e. what if they forget to write the color or material type?), 2. the warehouse personnel will have a more difficult time locating and picking the goods for shipment, and again more errors may occur, and 3. the accounting personnel will also have a more tedious job posting to the subsidiary ledgers and errors may occur.

19. a. *state codes*—alphabetic code, i.e. PA, this method is appropriate because it corresponds with the postal services abbreviation and is meaningful to humans.
- b. *check number*—numeric, sequential. This method allows the checks

to be examined to determine if any are missing.

- c. *chart of accounts*—block coding since this method allows a whole class of items to be restricted to a specific range. i.e. assets 100-199, liabilities 200-299, equity accounts, 300-399.
- d. *inventory item number*—alpha-numeric. The numeric portion allows the items to be easily sorted and found. The alphabetic portion allows more combinations to be made with fewer digits or characters. i.e. 2000A, 2000B, 2000C could represent virtually the same inventory item but in three different sizes.
- e. *bin number (inv warehouse location)*—group codes since certain digits may be used to represent which warehouse, certain digits may be used to represent floor, certain digits may be used to represent rows, certain digits may be used to represent bins. i.e. 211225 could represent warehouse 2, floor 1, row 12, and bin #25.
- f. *sales order number*—numeric, sequential. This method allows the sales orders to be examined to determine if any are missing.
- g. *vendor code*—alpha-numeric. The alphabetic portion allows more meaningful codes to be used and found. The numeric portion allows different firms with similar names to be distinguished. i.e. ALPH01, ALPH02 where ALPH01 is the vendor code for Alphahydraulics and ALPH02 is the vendor code for Alpha Trucking Services. Once the name of the company is known, finding the vendor code is much easier than if only numbers are used.

- h. *invoice number*—numeric, sequential. This method allows the invoices to be examined sequentially. Gaps in the sequence may signify missing invoices.
- i. *customer number*—same as for vendor code.

MULTIPLE CHOICE

1. B
2. A
3. A
4. D
5. D
6. B
7. B
8. E
9. C
10. D
11. A
12. B
13. E
14. A
15. D
16. B
17. B
18. C
19. A
20. C
21. A
22. C

PROBLEMS

1. TRANSACTION CYCLE IDENTIFICATION

- a. Expenditure cycle-payroll subsystem.
- b. Conversion cycle-production system subsystem.
- c. Revenue cycle-cash receipts subsystem..
- d. Revenue cycle-sales order processing subsystem.
- e. Expenditure cycle-purchases subsystem.
- f. Conversion cycle-production subsystem.

2. TYPES OF FILES

- a. master file
- b. transaction file
- c. reference file
- d. archive file
- e. master file
- f. transaction file
- g. reference file
- h. archive file

3. SYSTEM FLOWCHART

Solution to problem 2-3

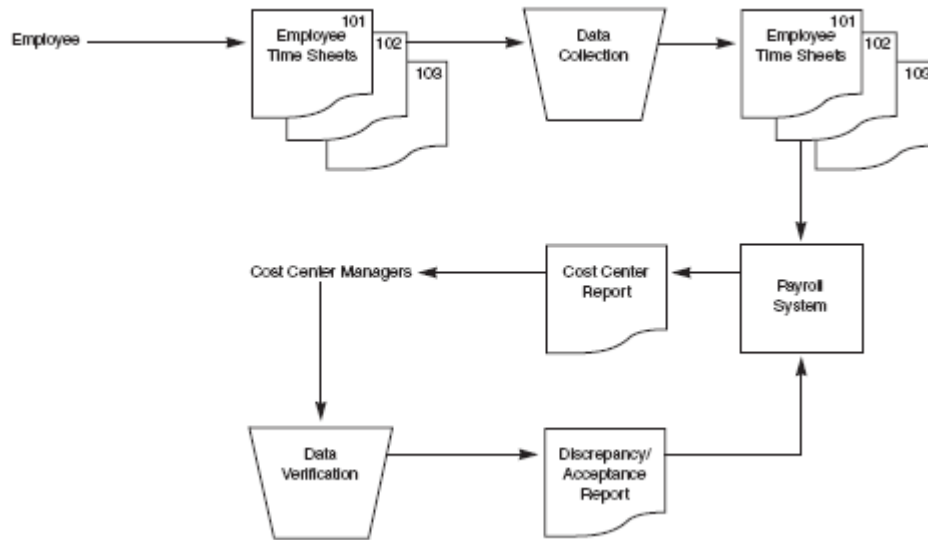

4. SYSTEM FLOWCHART

Solution to Problem 4 System Flowchart

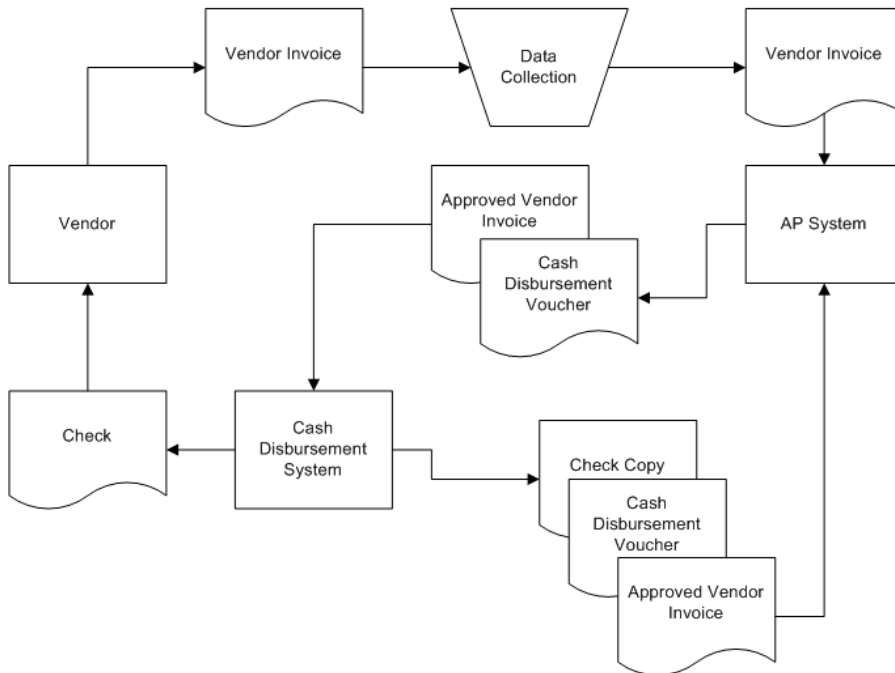

5 .

Receiving report file

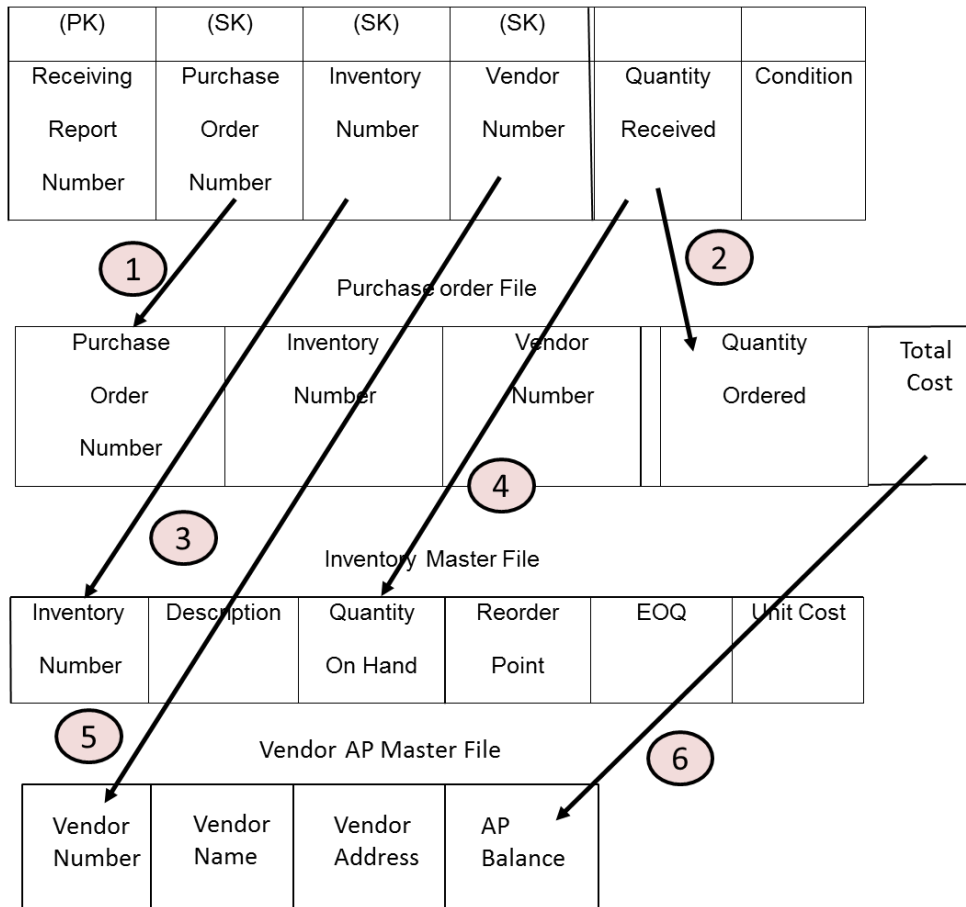

- 1) System reads the Receiving Report record and matches it to the PO record using the PO Number.
- 2) System verifies that quantities received were constant with what was ordered.
- 3) Match the Receiving Report to the Inventory Master record
- 4) Update the Quantity on Hand in Inventory using the Quantity Received
- 5) Match the Receiving report record (or the PO) to Vendor AP file record using Vendor Number.
- 6) Update the AP Balance using the Total cost field in the PO Record.

6. RECORD STRUCTURES

Cash Receipts file

(PK)	(SK)			
Cash Receipt Number	Customer Number	Customer Check Number	Remittance Amount	Remittance Date

AR (Sub) Master File

Customer Number	Customer Name	Customer Address	Current Balance	Credit Limit	Last Payment Date	Billing Date
-----------------	---------------	------------------	-----------------	--------------	-------------------	--------------

Cash (GL) Master File

GL Acct Number	Description	Total Debits	Total Credits	Account Balance
----------------	-------------	--------------	---------------	-----------------

AR Control (GL) Master File

GL Acct Number	Description	Total Debits	Total Credits	Account Balance
----------------	-------------	--------------	---------------	-----------------

Explanation:

- 1) System reads the Cash Receipts record and matches it to the AR Sub record using the Customer Number.
- 2) System updates the Current Balance in the in the AR Sub record using the Remittance Date in the Cash Receipts record.
- 3) System updates the Last Payment Date in the in the AR Sub record using the Remittance Date in the Cash Receipts record.

4) System automatically accesses the Cash record in the GL File and updates Total Debits from the Remittance Amount in the Cash Receipts record.

5) System automatically accesses the AR Control record in the GL File and updates Total Credits from the Remittance Amount in the Cash Receipts record.

Note: Steps 4 and 5 may be accomplished in real Time or batch mode.

7. SYSTEM FLOWCHART

- a. Symbol 1 is a terminal showing the source or destination of a document or report; symbol 2 is source document.
- b. Symbols 3 and 4 depict the entry of data in real time into a system from a computer terminal.
- c. Symbols 4 and 5 depict the storage/retrieval of data to/from a computer disk.
- d. Symbols 6, 8, and 9 depict the processing of a source document and its placement into a file.

8. System Flowchart

Time sheets are collected in a batch, and the relevant data are manually keyed into the system. The payroll data are then stored on a magnetic disk. An edit program then verifies whether the employee number is valid by checking it against an employee master file. The validity of the cost center assigned is also verified against a master file. Logical and clerical errors are also tested, such as an employee working an unreasonable number of hours in a day/week. The good records, those that pass all the edit tests, are stored in the Edited Transactions file. Records that are found to be in error are sent to an error file. These errors are investigated, corrected, and reentered into the system. The Update program reads the edited transaction records, one at a time, and updates any corresponding fields in the master files. Finally, a report program generates paychecks and management reports.

9. SYSTEM FLOWCHARTS AND PROGRAM FLOWCHARTS

Any of the following types of errors may cause a payroll record to be placed in the error file:

- a. invalid employee number
- b. invalid cost center
- c. incorrect batch/control total that does not equal the totals computed by the program

A program flowchart is presented below.

solution to problem 2-9

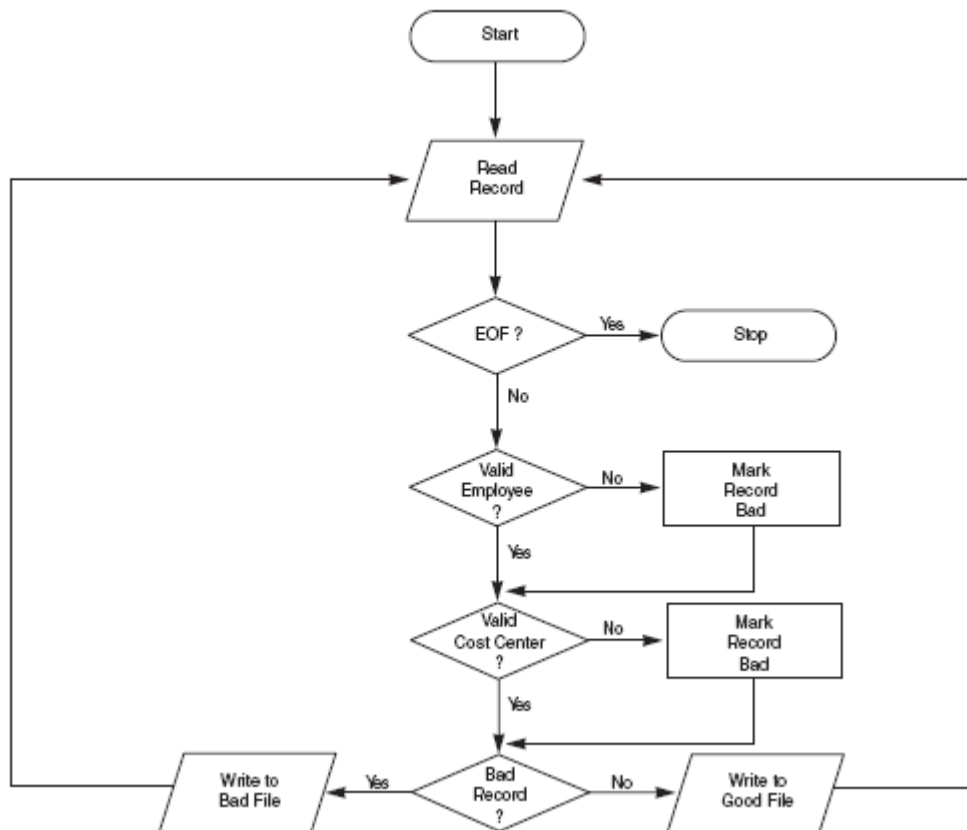

10. TRANSACTION CYCLE RELATIONSHIP

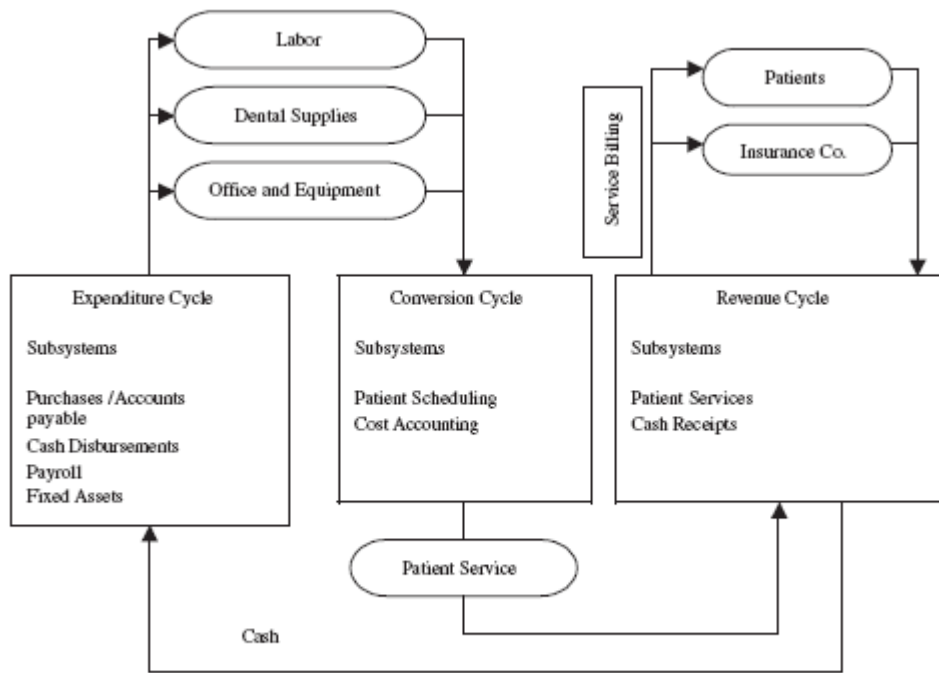

11. SYSTEM FLOWCHART MANUAL SALES PROCEDURES

Solution to Problem 2-11

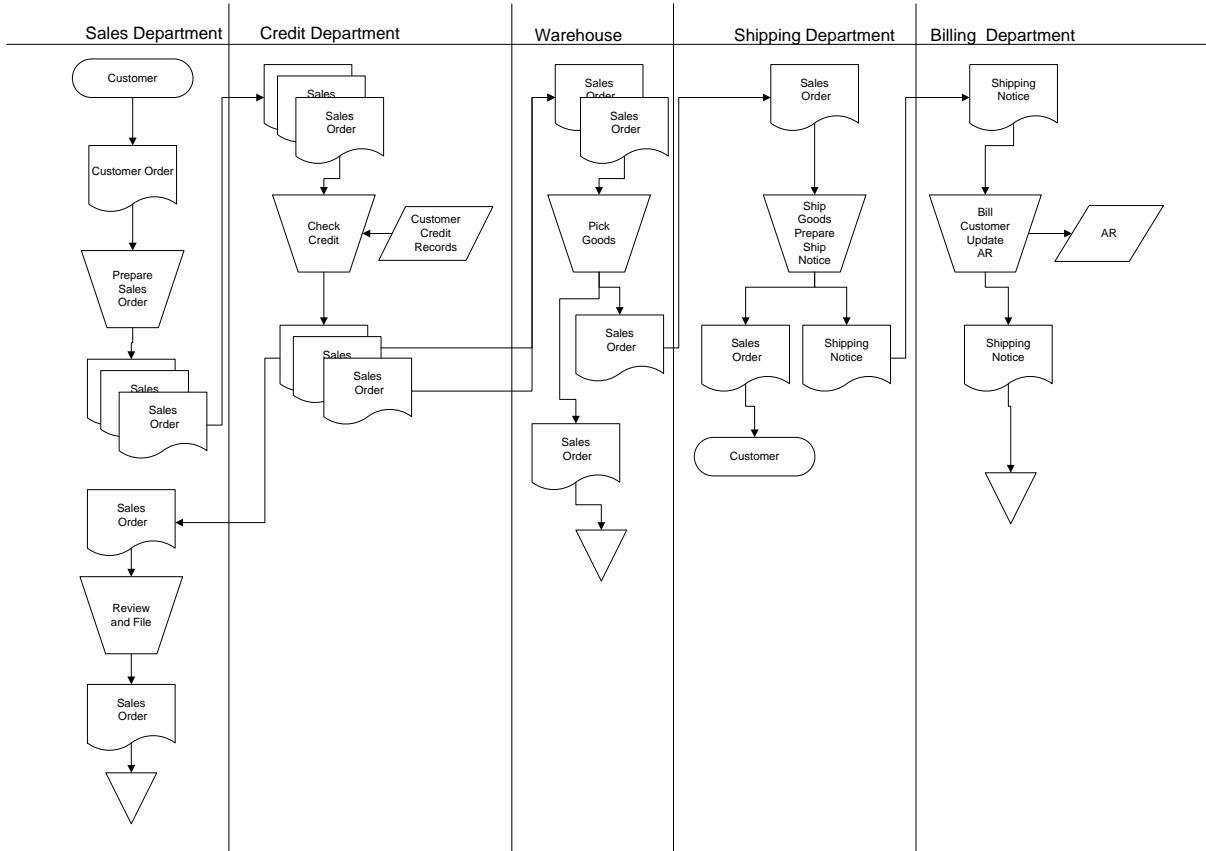

12. SYSTEM DOCUMENTATION – EXPENDITURE CYCLE

See the drawings on this and the following page.

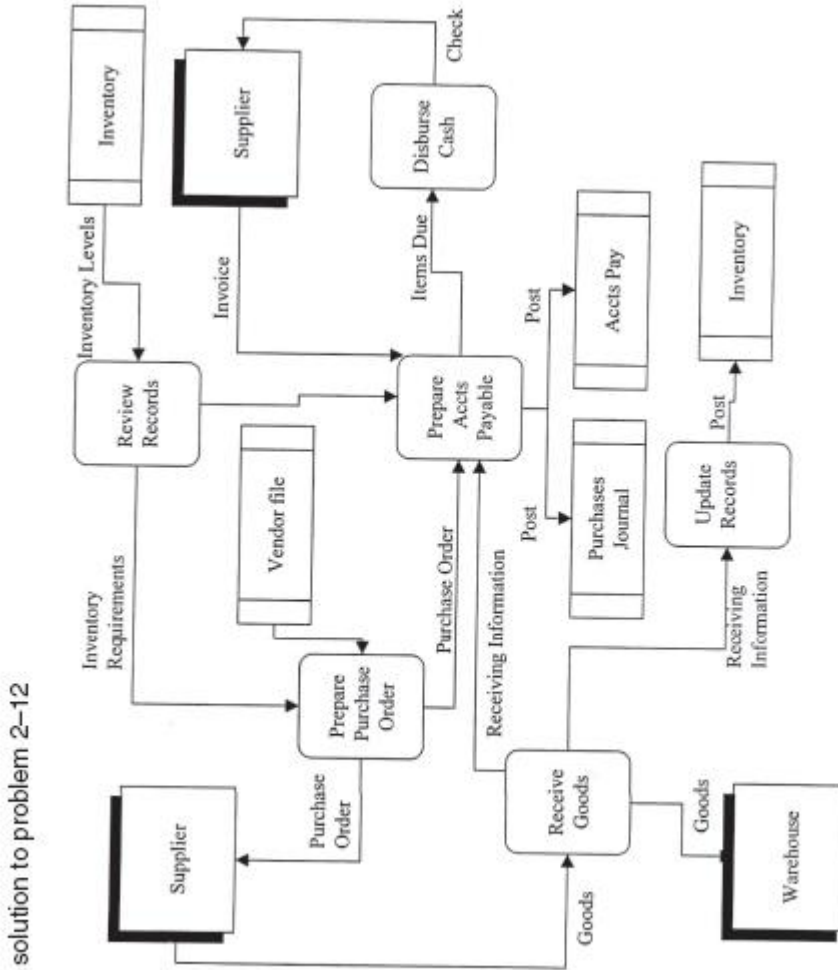

13. SYSTEM DOCUMENTATION – CASH RECEIPTS

Solution to Problem 2-13

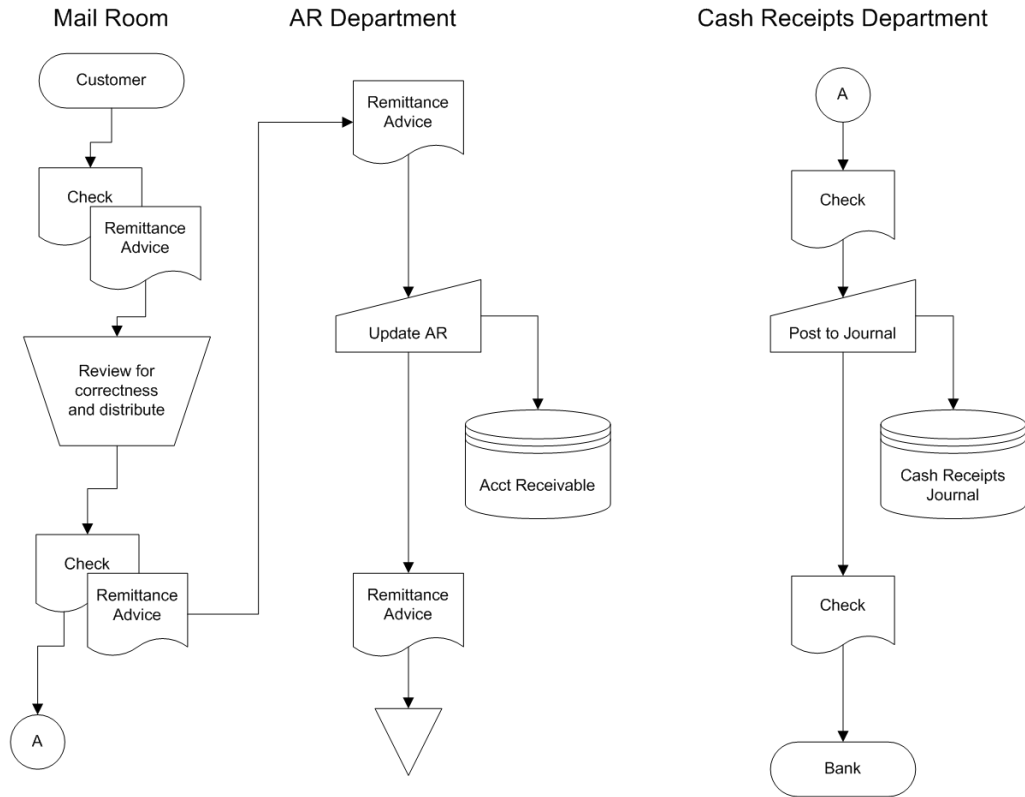

14. SYSTEM DOCUMENTATION PAYROLL

See drawings on the following pages.

Solution to Problem 2-14
Data Flow Diagram for Payroll

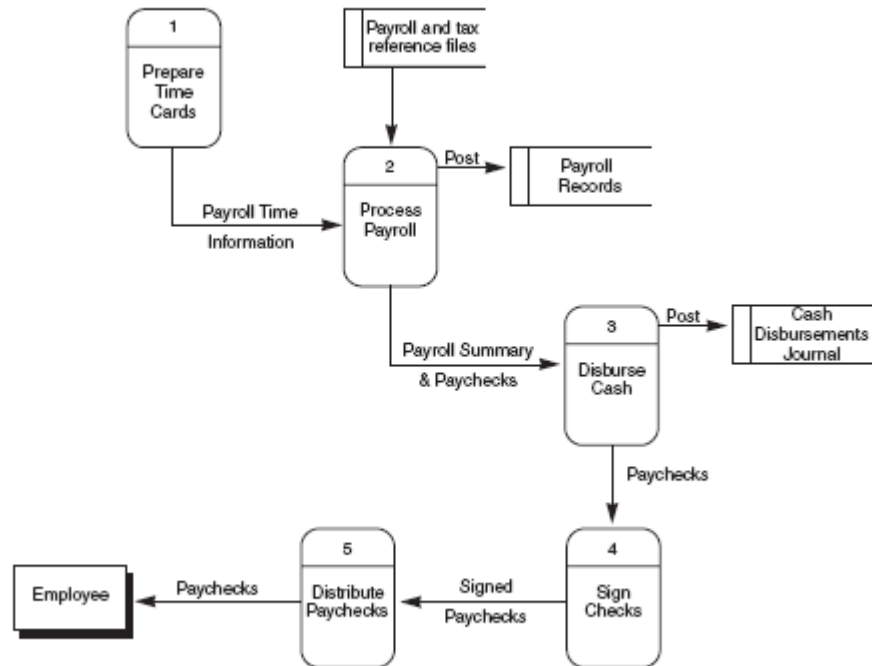

Solution to Problem 2-14
Flowchart for Payroll

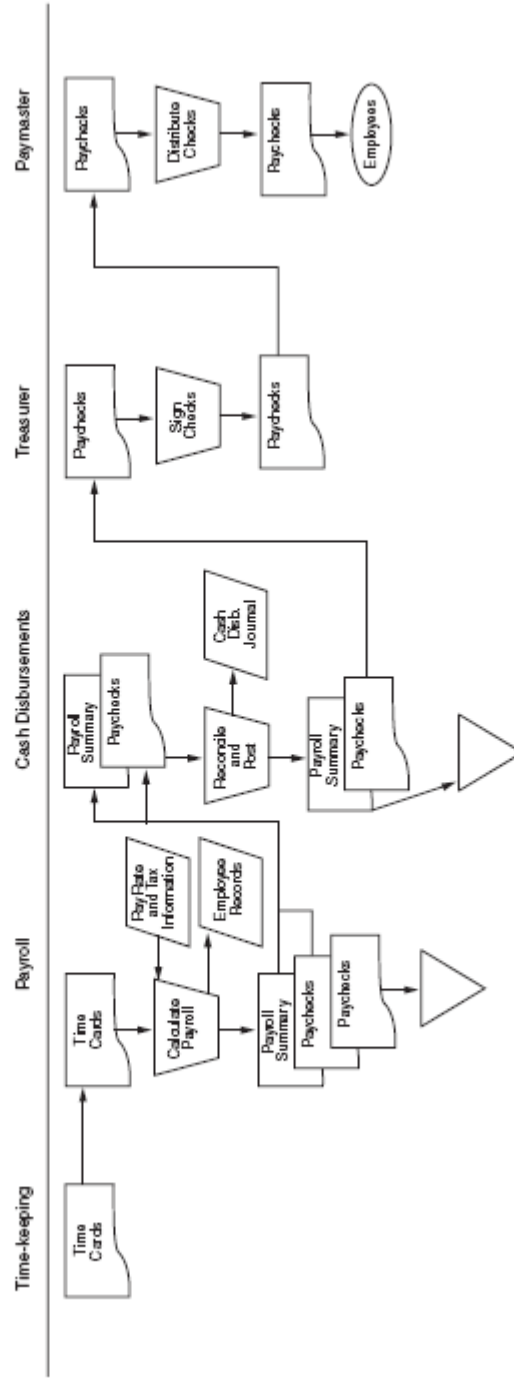

15. SYSTEMS DOCUMENTATION – PAYROLL

See the data flow diagram, ER diagram, and flowchart on the following pages.

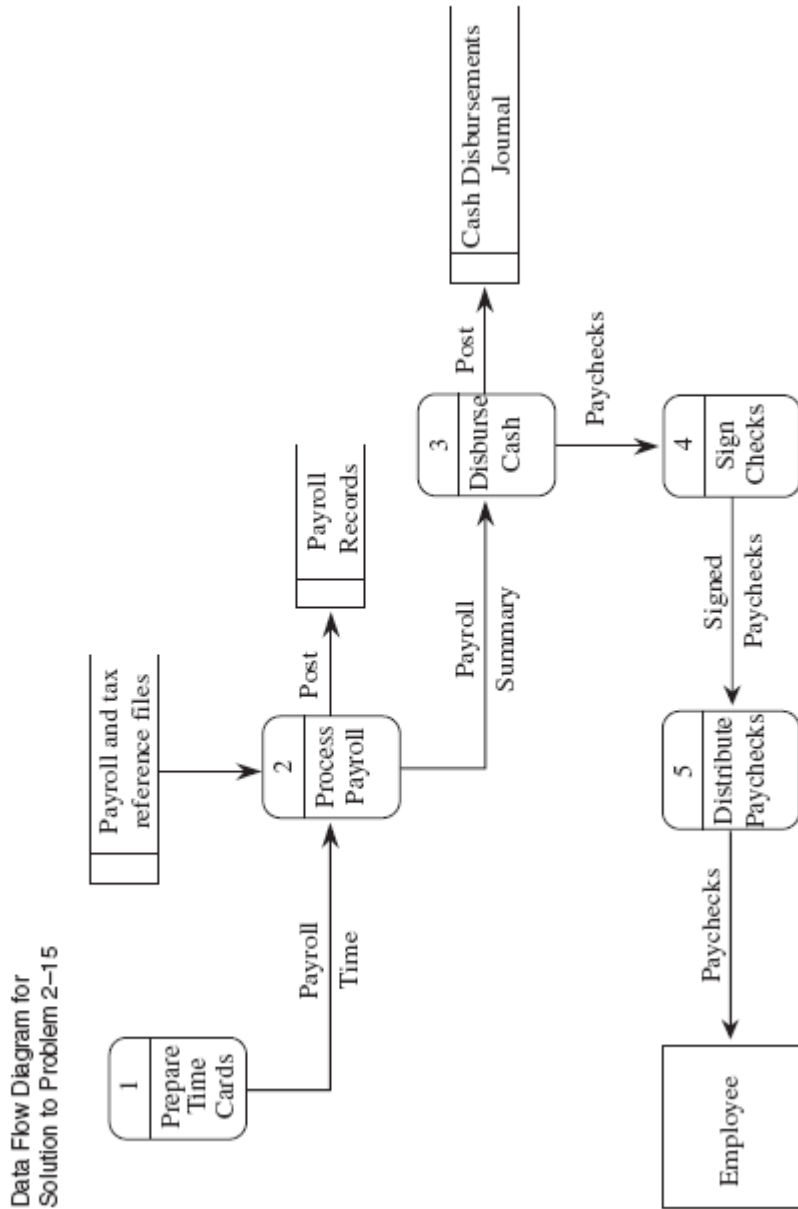

Solution to Problem 2-15
Flowchart for Computer Payroll System

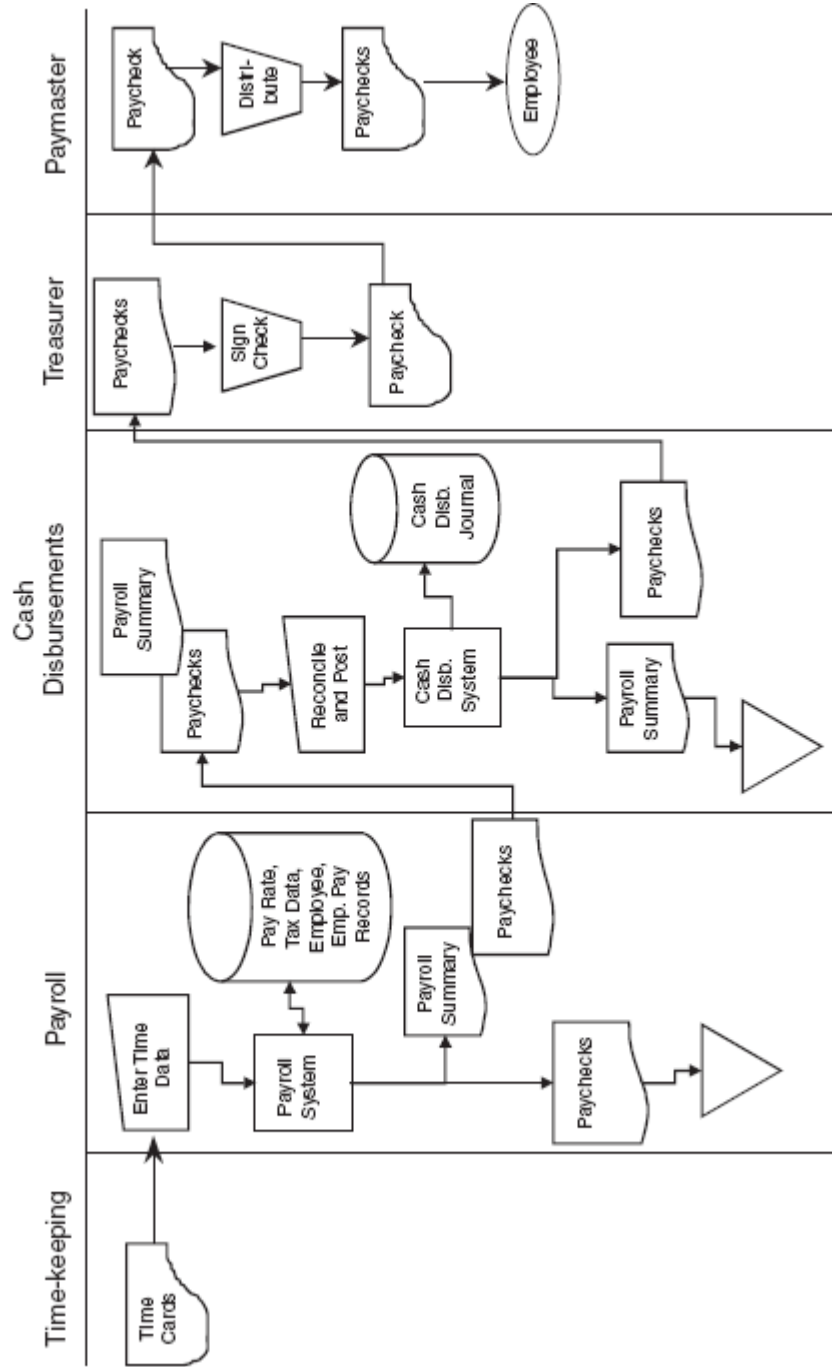

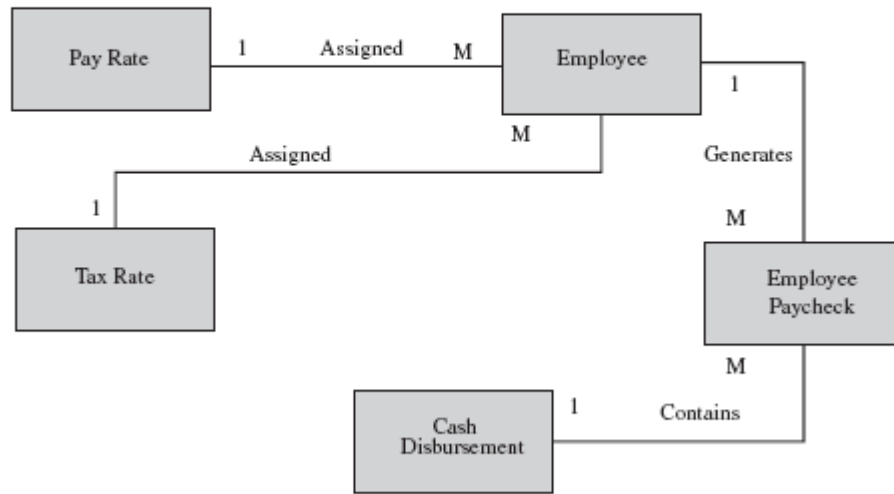

16. SYSTEM DOCUMENTATION – REVENUE CYCLE

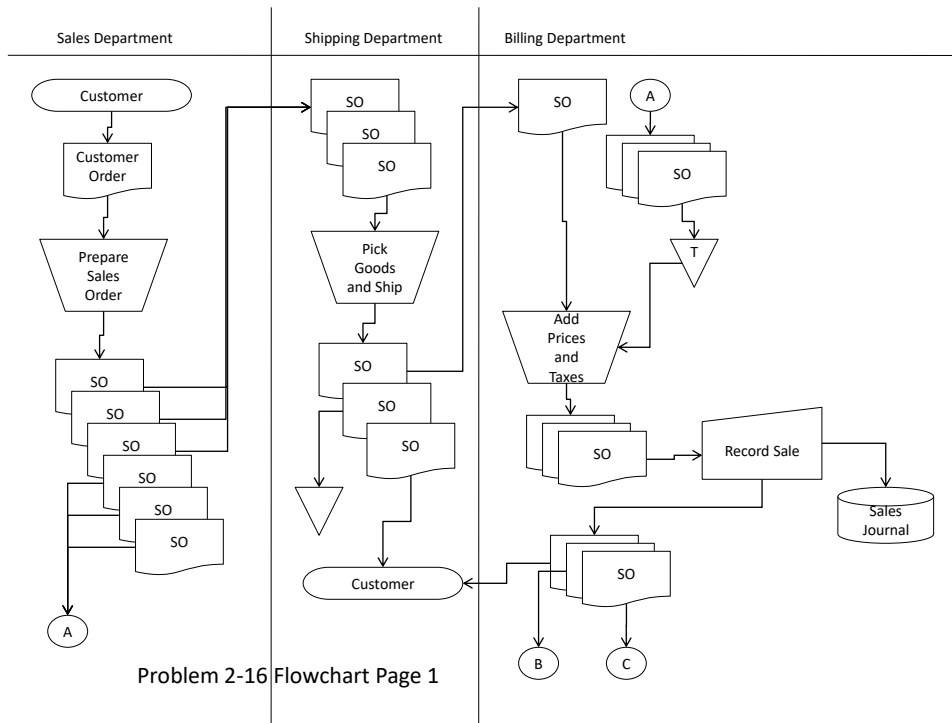

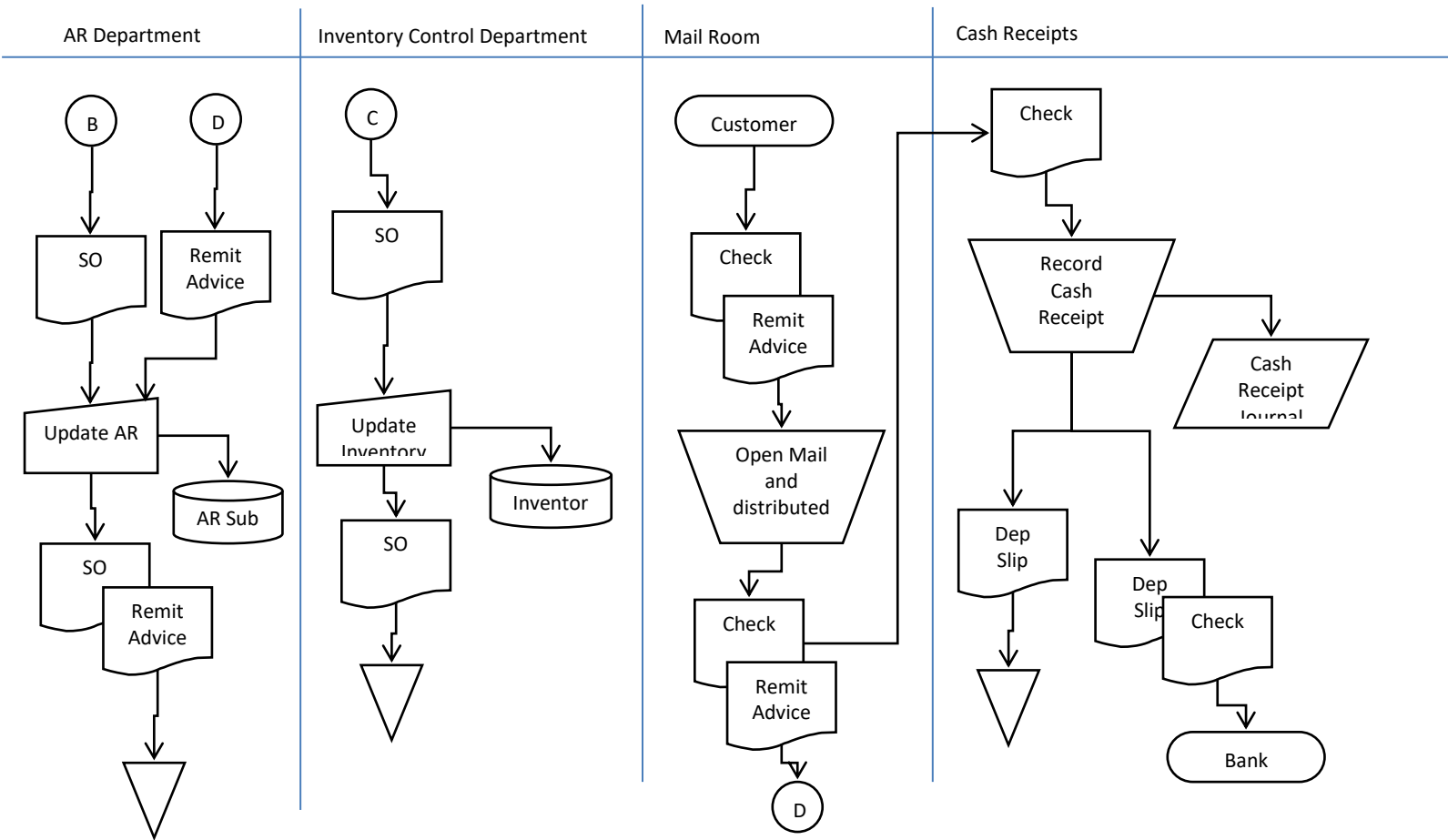

Problem 2-16 Flowchart Page 2

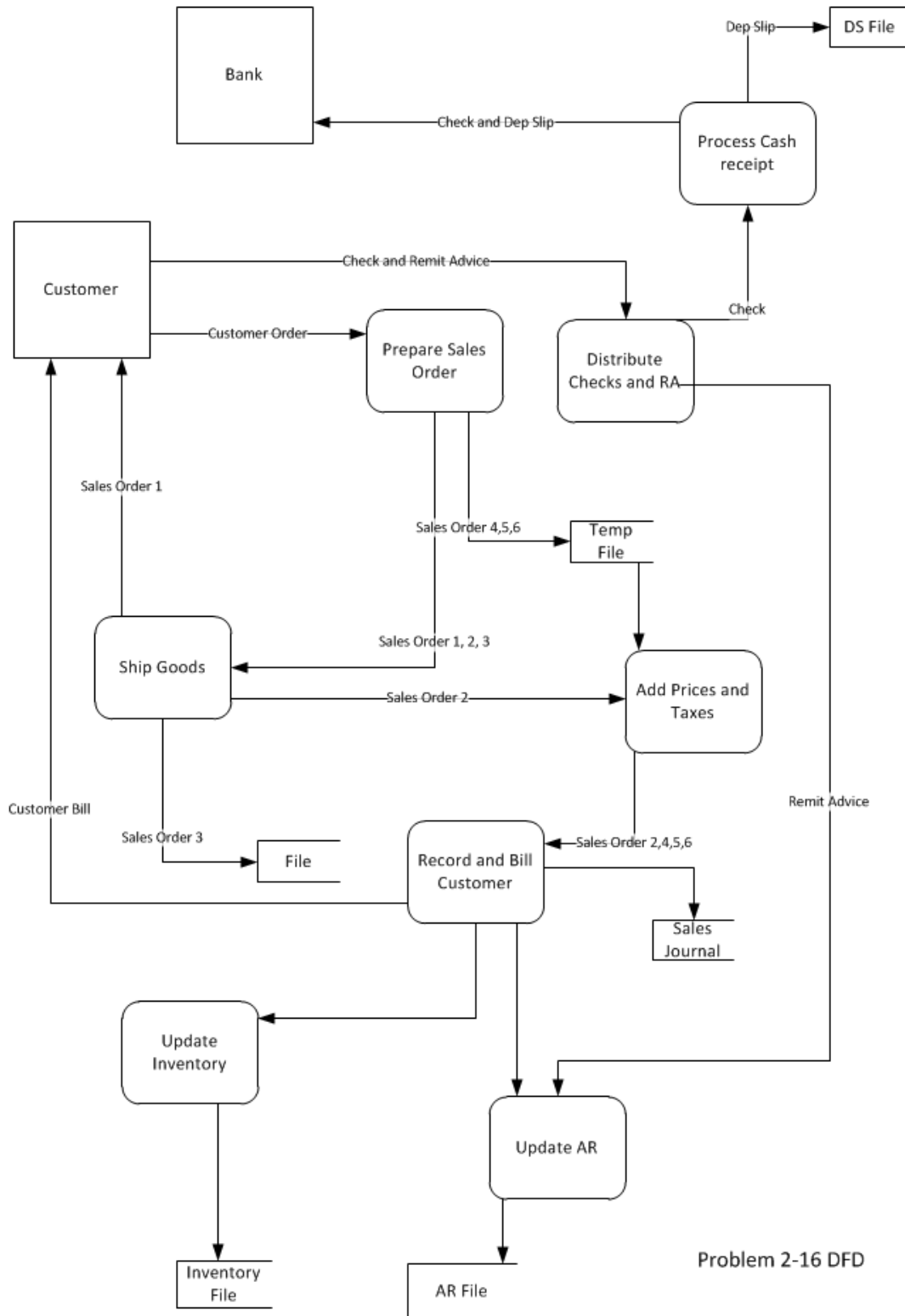

Problem 2-16 DFD

17. SYSTEM DOCUMENTATION EXPENDITURE CYCLE

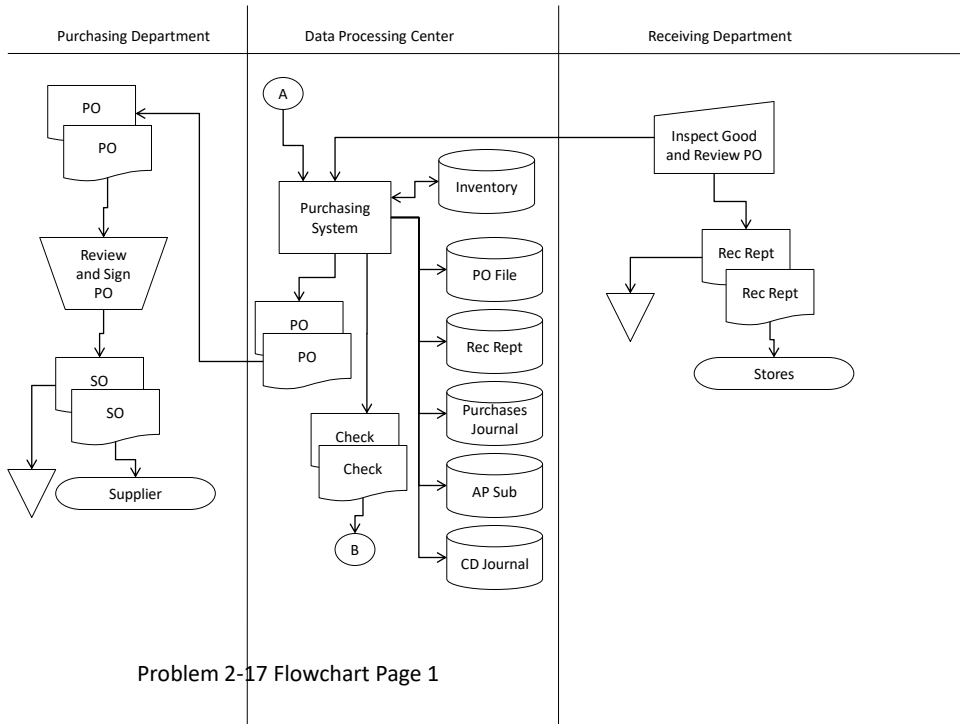

Problem 2-17 Flowchart Page 1

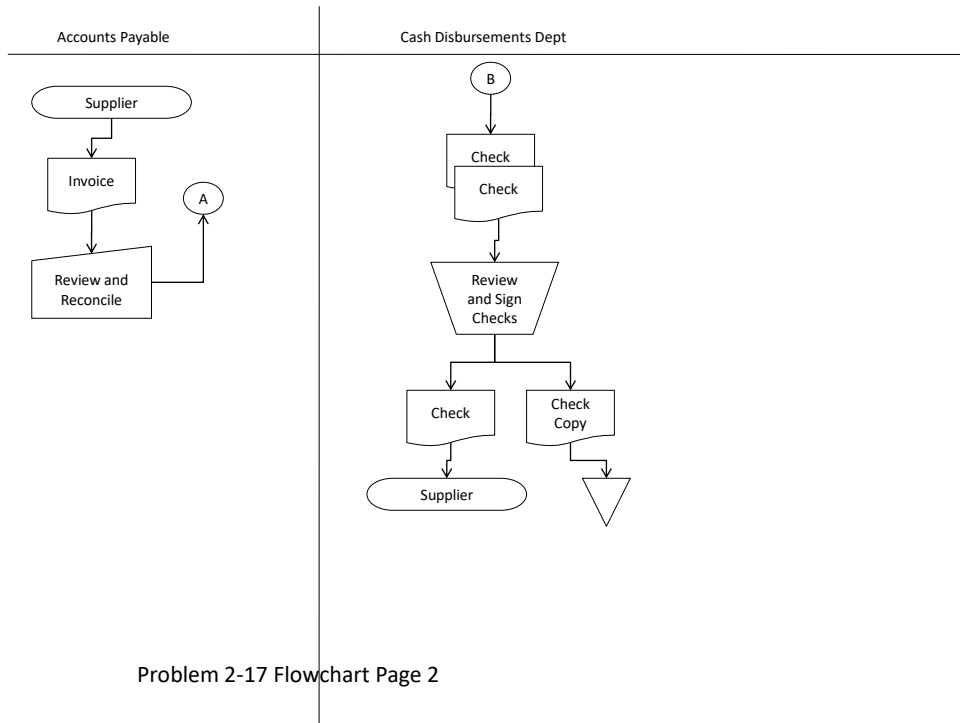

Problem 2-17 Flowchart Page 2

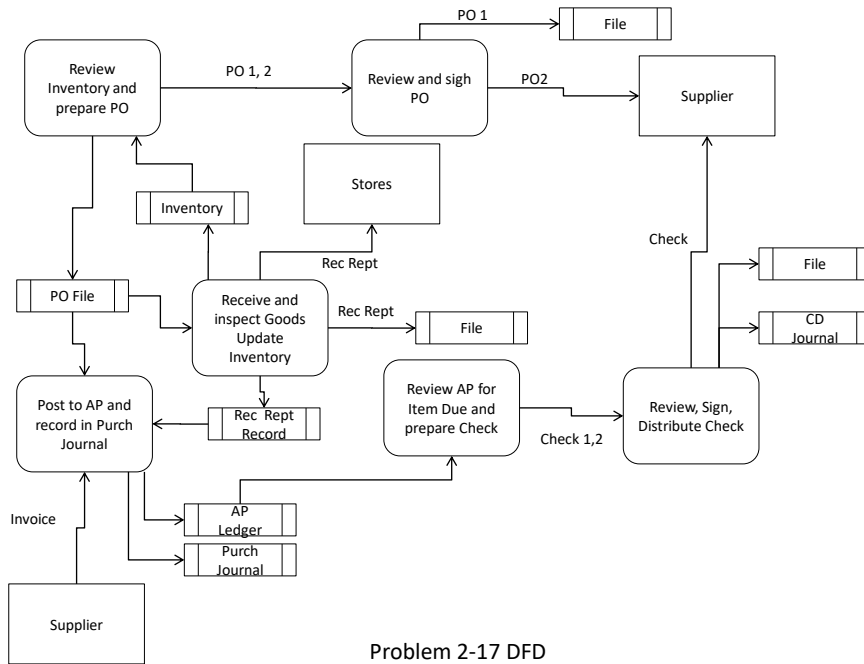

Problem 2-17 DFD

18.
Solution to Problem 2-18 – Cash Receipts Centralized DP System

Cash Receipts System Flowchart

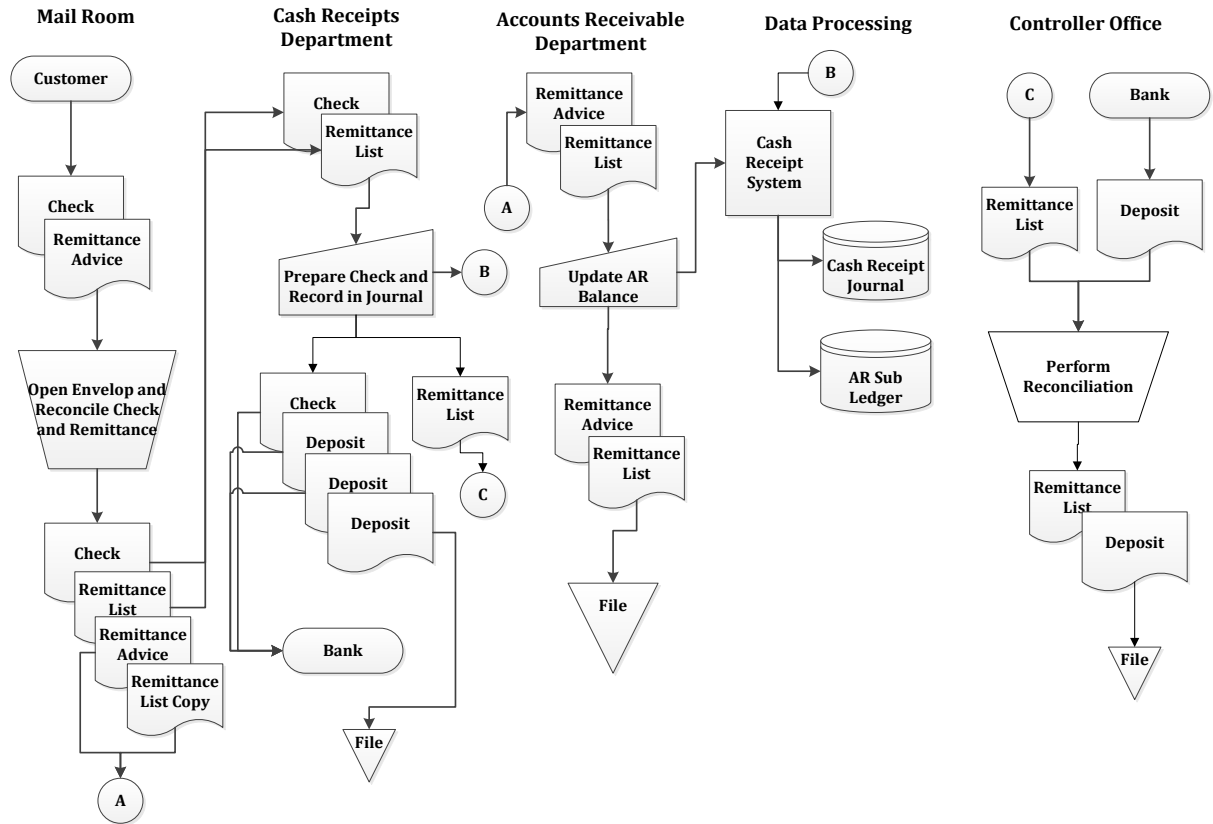

19.

Solution to Problem 2-19 Purchases System Centralized Data Processing

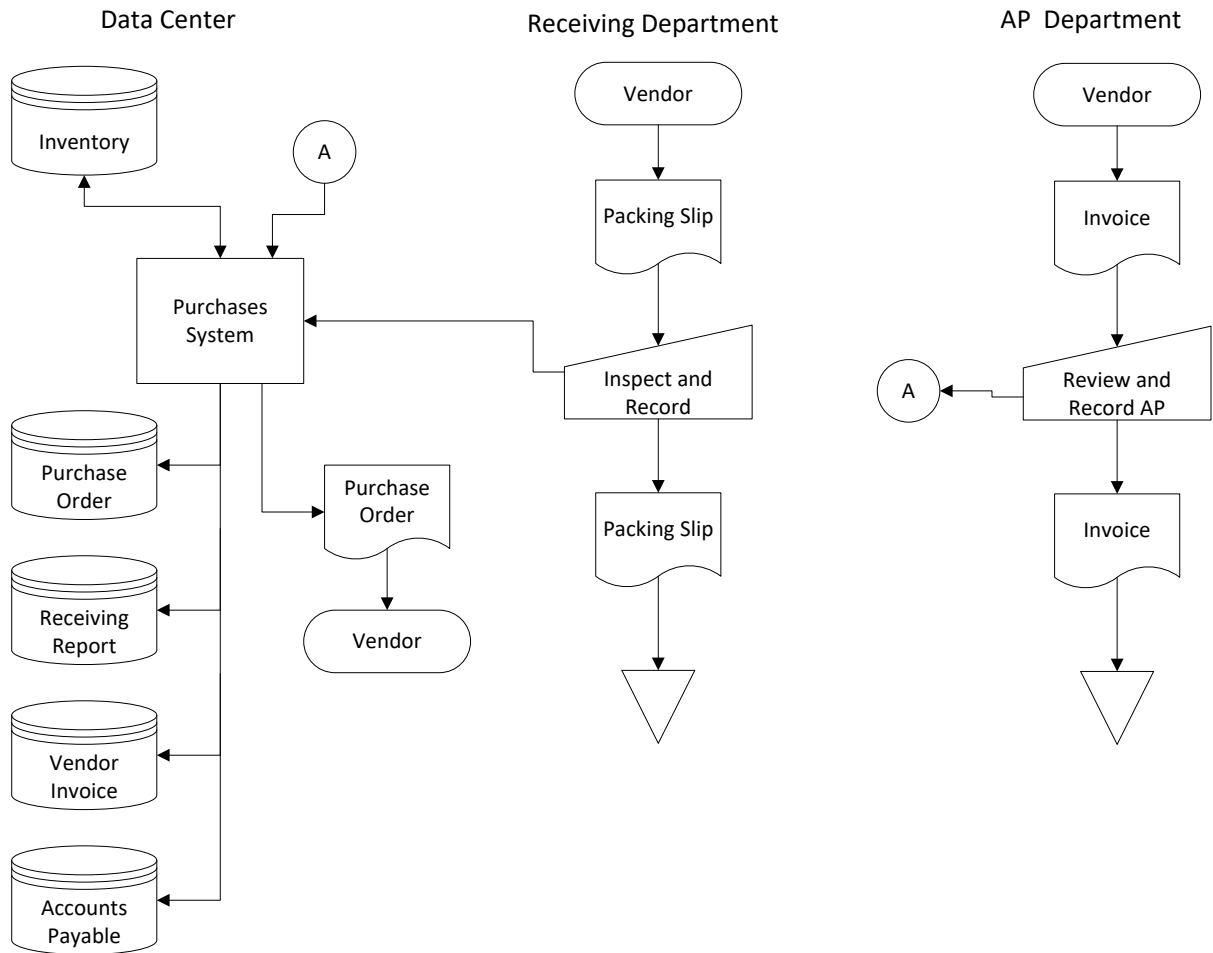

20. SYSTEM DOCUMENTATION CASH DISBURSEMENT

Solution to Problem 2-20, Cash disbursement Procedures (Centralized DP)

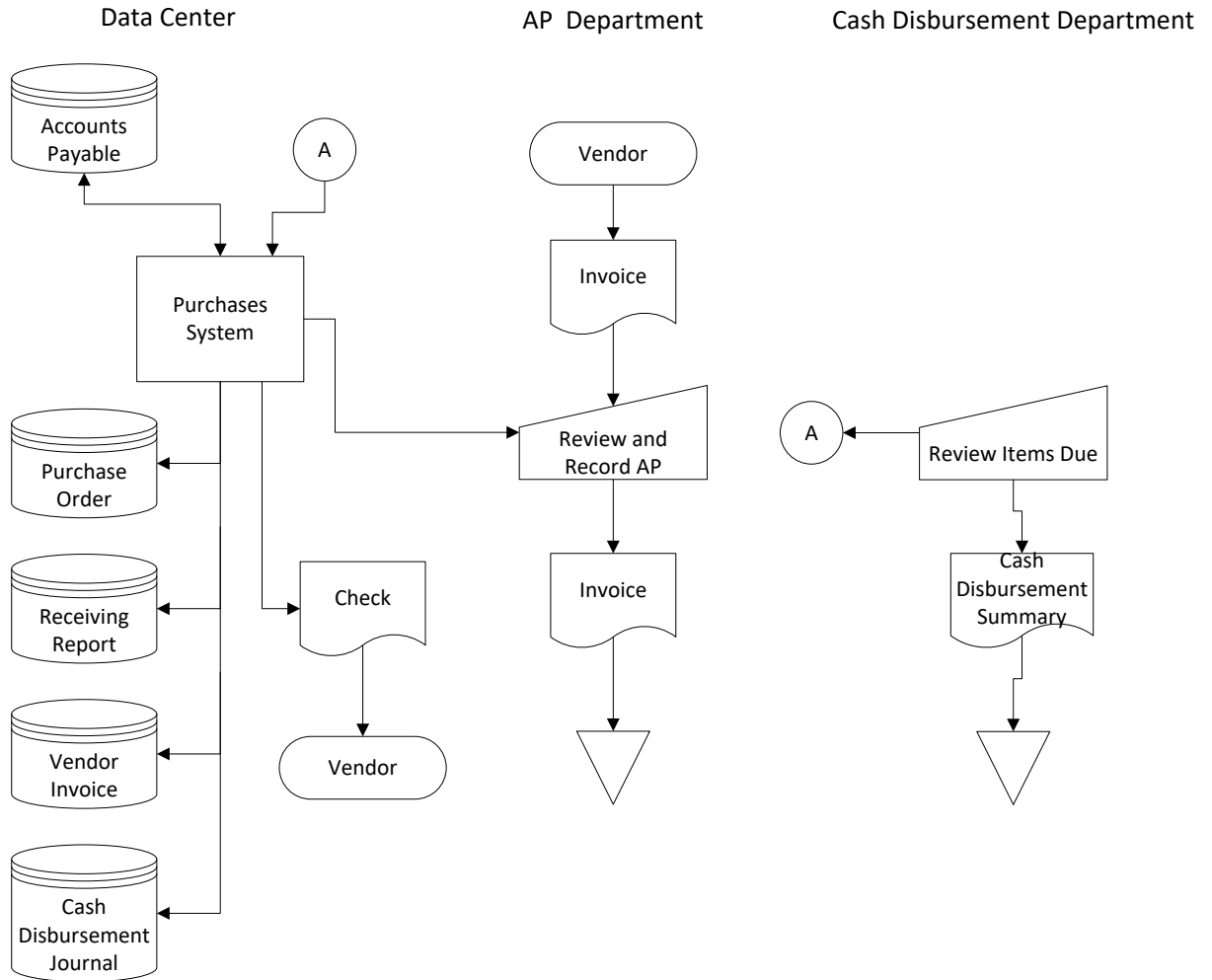

21. CODING SCHEME

101.0	Cash
102.0	Accounts Receivable
103.0	Office Supplies Inventory
104.0	Prepaid Insurance
105.0	Inventory
121.0	Investments in Marketable Securities
131.0	Delivery Truck
131.5	Accumulated Depreciation – Delivery Truck
132.0	Equipment
132.5	Accumulated Depreciation – Equipment
133.0	Furniture and Fixtures
133.5	Accumulated Depreciation – Furniture and Fixtures
134.0	Building
134.5	Accumulated Depreciation – Building
135.0	Land
201.0	Accounts Payable
202.0	Wages Payable
203.0	Taxes Payable
221.0	Notes Payable (Long-term)
222.0	Bonds Payable
301.0	Common Stock
302.0	Paid in Capital in Excess of Par

311.0	Treasury Stock
390.0	Retained Earnings
401.0	Sales
401.5	Sales Returns and Allowances
420.0	Dividend Income
501.0	Cost of Goods Sold
501.0	Wages Expense
521.0	Utility Expense
522.0	Office Supplies Expense
531.0	Insurance Expense
541.0	Depreciation Expense
551.0	Advertising Expense
561.0	Fuel Expense
571.0	Interest Expense

22. CODING SCHEME

The following scheme uses group codes with alphabetic and numeric data since they can be used to categorize information in a hierarchical form.

<u>Warehouse</u>	<u>Aisle</u>	<u>Side of Aisle</u>	<u>Shelf</u>	<u>Bin</u>
1	C	L	5	08

Thus, code 1CL08 represents the above. 2AR415 represents inventory in warehouse #2, aisle A, right side of aisle, shelf 4, bin #15.

23. FLAT FILE VS DATABASE MODEL

The problems with flat files that are resolved by Database technology include:

Data Storage --- Flat files result in considerable data redundancy and storage problems

Data Updating -- When users keep separate files, all changes must be made separately for each user. This adds significantly to the task and the cost of data management.

Currency of Information -- If update information is not properly disseminated, the change will not be reflected in some users' data, resulting in decisions based on outdated information.

Task-Data Dependency -- The user's information set is constrained by the data that he or she possesses and controls

Flat Files Limit Data Integration -- The flat-file approach is a single-view model. Files are structured, formatted, and arranged to suit the specific needs of the owner or primary user of the data.

24. ACCESS METHODS

- a. **indexed sequential or indexed random; least optimal: sequential**
- b. indexed random or hashing; least optimal: sequential
- c. sequential; least optimal: indexed random
- d. sequential or pointer; least optimal; indexed random
- e. indexed random or hashing; least optimal: sequential
- f. indexed random or hashing; least optimal: sequential
- g. indexed random; least optimal: hashing

25. FILE ORGANIZATION

- a. A sequential file could be used, but with only eight updates per month, in charge of utilities.
- b. Random access for customer balances and payment information is crucial. A network or relational database is necessary since this is a many-to-many relationship: many purchases per customer, many merchants per customer, many customers per merchants.
- c. Random access will be necessary for flight inquiries and updates throughout the day. A navigational database would be appropriate. Only one direction needs to be investigated. Most customers start with a departure city and then flights to the destination city can be investigated. Many different destinations will exist for a given departure city. Rarely will a customer wish to book a flight based on a destination

where they do not know from which city they will depart.

- d. A random access storage device is necessary to access the students' records quickly when they check out books. A network or relational database will be necessary since the data should be bidirectional. An investigation may need to be conducted to determine what books a student has checked out or an investigation may need to be conducted regarding who has a certain book checked out that has been recalled.