

Chapter 2 Modeling Data in the Organization

Chapter Overview

The purpose of this chapter is to present a detailed description of the entity-relationship model and the use of this tool within the context of conceptual data modeling. This chapter presents the basic entity-relationship (or E-R) model. Advanced features of conceptual data modeling will follow in Chapter 3.

Chapter Objectives

Specific student learning objectives are included in the beginning of the chapter. *From an instructor's point of view, the objectives of this chapter are to:*

1. Emphasize the importance of understanding organizational data, and convince your students that unless they can represent data unambiguously at the conceptual level, they cannot implement a database that will effectively serve the needs of various organizational stakeholder groups.
2. Present the E-R model as a conceptual data model that can be used to capture the structure and much, although not all, of the semantics (or meaning) of data.
3. Apply E-R modeling concepts to several practical examples including the Pine Valley Furniture Company case.

Key Terms

Associative entity	Entity type	Optional attribute
Attribute	Entity-relationship diagram (E-R diagram)	Relationship instance
Binary relationship		Relationship type
Business rule	Entity-relationship model (E-R model)	Required attribute
Cardinality constraint		Simple (or atomic) attribute
Composite attribute	Identifier	Strong entity type
Composite identifier	Identifying owner	Ternary relationship
Degree	Identifying relationship	Time stamp
Derived attribute	Maximum cardinality	Unary relationship
Entity	Minimum cardinality	Weak entity type
Entity instance	Multivalued attribute	

Classroom Ideas

1. Review the major steps in the database development process (Figures 1-7 and 1-8) and highlight the importance of data modeling in determining the overall data requirements of information systems. Lead a discussion regarding the parties within an organization that typically are most heavily involved in each of the steps and how end users may best participate in the process.
2. Introduce the concept of drawing models to represent information in a concise manner by having your students participate in a small active exercise in map-making. Divide the

- students into teams of 3 – 4 each so that you have an even number of teams in the class. Instruct each team to work together to investigate and develop a map to selected campus locations (you develop the list ahead of time; e.g., from this classroom to the library, from this classroom to a colleague’s office, etc.). Ask each team to verify the map they draw and then return to the classroom. Pair up each team with a unique location with another team; ask the teams to exchange maps. Instruct each team to then verify the map they received by following it and then returning to the classroom. Conduct a debriefing discussion about how easy/hard it was to follow the maps, how useful were the symbols used, how easily understood were the symbols, etc. Use this discussion to lead into the use of E-R notation used to represent data models and why standardization is useful to systems development activities.
3. Use the sample E-R diagram shown in Figure 2-1 to introduce the first conceptual model to your students. Ask them to explain the business rules represented in this diagram.
 4. Use Figure 2-2 to summarize the basic E-R notation used in this chapter and throughout the remainder of the text.
 5. Contrast the terms entity type and entity instance (see Figure 2-3). Discuss other examples: STUDENT with each student in the classroom as an instance, etc. Warn the students that the term “entity” is often used either way; the meaning is intended to come from the *context* in which it is used.
 6. Give examples of common errors in E-R diagramming, including inappropriate entities (see Figure 2-4). Ask your students for other examples.
 7. Compare strong versus weak entities using Figure 2-5. Ask your students for other examples.
 8. Discuss the various types of attributes that are commonly encountered (Figures 2-7 through 2-9). Again, ask your students to think of other examples.
 9. Make sure your students understand the difference between relationship types and relationship instances (Figure 2-10).
 10. Introduce the notion of an associative entity by using Figure 2-11. Discuss the four reasons (presented in the text) for converting a relationship to an associative entity.
 11. Discuss unary, binary, and ternary relationships (Figure 2-12). Have the students brainstorm at least two additional examples for each of these relationship degrees.
 12. Discuss the bill-of-materials unary relationship (Figure 2-13). Use a simple and familiar product (such as a toy) to illustrate this essential structure, which is often difficult for students to understand.
 13. Introduce the concept and notation of cardinality constraints in relationships (Figures 2-16, 2-17, and 2-18). Emphasize that these constraints are important expressions of business rules.
 14. Introduce the problem of representing time dependent data. Use Figure 2-19 to illustrate one technique for coping with time dependencies.
 15. Discuss examples of multiple relationships between entities (Figure 2-20). Ask your students to suggest other examples.
 16. Use the diagram for Pine Valley Furniture Company (Figure 2-21) to illustrate a more comprehensive E-R diagram. Stress that in real-world situations, E-R diagrams are often much more complex than this example.
 17. As time permits, have your students work in small teams, 2 or 3 students each, to solve

some of the E-R diagramming tasks in the Problems and Exercises section of the chapter.

Answers to Review Questions

1. *Define each of the following terms:*
 - a. *Entity type.* A collection of entities that share common properties or characteristics
 - b. *Entity-relationship model.* A logical representation of the data for an organization or for a business area
 - c. *Entity instance.* A single occurrence of an entity type
 - d. *Attribute.* A property or characteristic of an entity type that is of interest to the organization
 - e. *Relationship type.* A meaningful association between (or among) entity types
 - f. *Identifier.* An attribute (or combination of attributes) that uniquely identifies individual instances of an entity type
 - g. *Multivalued attribute.* An attribute that may take on more than one value for a given entity instance
 - h. *Associative entity.* An entity type that associates the instances of one or more entity types and contains attributes that are peculiar to the relationship between those entity instances
 - i. *Cardinality constraint.* Specifies the number of instances of one entity that can (or must) be associated with each instance of another entity
 - j. *Weak entity.* An entity type whose existence depends on some other entity type
 - k. *Identifying relationship.* The relationship between a weak entity type and its owner
 - l. *Derived attribute.* An attribute whose values can be calculated from related attribute values
 - m. *Business rule.* A statement that defines or constrains some aspect of the business

2. *Match the following terms and definitions:*
 - i composite attribute
 - d associative entity
 - b unary relationship
 - j weak entity
 - h attribute
 - m entity
 - e relationship type
 - c cardinality constraint
 - g degree
 - a identifier
 - f entity type
 - k ternary
 - l bill-of-materials

3. *Contrast the following terms:*
 - a. *Stored attribute; derived attribute.* A stored attribute is one whose values are stored in the database, while a derived attribute is one whose values can be calculated or derived from related stored attributes.
 - b. *Simple attribute; composite attribute.* A simple attribute is one that cannot be broken down into smaller components, while a composite attribute can be broken down into component parts.
 - c. *Entity type; relationship type.* An entity type is a collection of entity instances that share common properties or characteristics, while a relationship type is a meaningful association between (or among) entity types.
 - d. *Strong entity type; weak entity type.* A strong entity type is an entity that exists independently of other entity types, while a weak entity type depends on some other entity type.
 - e. *Degree; cardinality.* The degree (of a relationship) is the number of entity types that participate in that relationship, while cardinality is a constraint on the number of instances of one entity that can (or must) be associated with each instance of another entity.
 - f. *Required attribute; optional attribute.* A required attribute must have a value for each entity instance, whereas an optional attribute may not have a value for every entity instance.
 - g. *Composite attribute; multivalued attribute.* A composite attribute has component parts that give meaning, whereas a multivalued attribute may take one or more values for an entity instance.
 - h. *Ternary relationship; three binary relationships.* A ternary relationship is a simultaneous relationship among the instances of three entity types and often includes attributes unique to that simultaneous relationship. Three binary relationships reflect the three two-way relationships between two entity types, and do not depict the same meaning as a ternary relationship.
4. *Three reasons underlying the importance of data modeling:*
 - a. The characteristics of data captured during data modeling are crucial in the design of databases, programs, and other system components. Facts and rules that are captured during this process are essential in assuring data integrity in an information system.
 - b. Data, rather than processes, are the most important aspects of many modern information systems and hence, require a central role in structuring system requirements.
 - c. Data tend to be more stable than the business processes that use the data. Thus, an information system that is based on a data orientation should have a longer useful life than one based on a process orientation.
5. *Where can you find business rules?* Business rules appear in descriptions of business functions, events, policies, units, stakeholders, and other objects. These descriptions can be found in interview notes from individual and group information systems requirements collection sessions, organizational documents, and other sources. Rules are identified by

asking questions about the who, what, when, where, why, and how of the organization.

6. *Six general guidelines:*

- a. Data names should relate to business, not technical characteristics.
- b. Data names should be meaningful, almost to the point of being self-documenting.
- c. Data names should be unique from the name used for every other distinct data object.
- d. Data names should be readable. The names should be structured in a way consistent with how the concepts would most naturally be said.
- e. Data names should be composed of words taken from an approved list.
- f. Data names should be repeatable, meaning that different people or the same person at different times should develop exactly or almost the same name.

7. *Four criteria:*

- a. Choose an identifier that will not change its value over the life of each instance of the entity type.
- b. Choose an identifier such that for each instance of the entity the attribute is guaranteed to have valid values and not be null (or unknown).
- c. Avoid the use of so-called intelligent identifiers (or keys), whose structure indicates classifications, locations, and so on.
- d. Consider substituting single-attribute surrogate identifiers for large composite identifiers.

8. *Why composite rather than simple?*

An identifier attribute is an attribute (or combination of attributes) whose value distinguishes individual instances of an entity type. Often, a simple attribute will not be unique for all instances of an entity type (e.g., FlightNumber for an instance of an airline flight). Rather, a combination of simple attributes will be needed to uniquely identify the entity instance (e.g., FlightID and FlightDate would make the instance unique).

9. *Three conditions for an associative entity type:*

- a. All of the relationships for the participating entity types are “many” relationships.
- b. The resulting associative entity type has independent meaning to end users, and it preferably can be identified with a single-attribute identifier.
- c. The associative entity has one or more attributes in addition to the identifier.

10. *Four types of cardinality constraints:*

- a. Optional one:

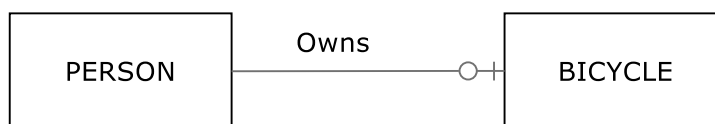

b. Mandatory one:

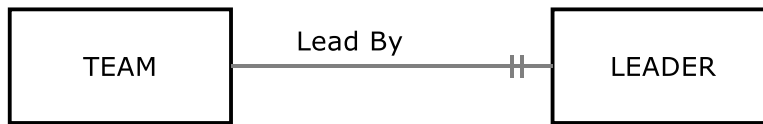

c. Optional many:



d. Mandatory many:



11. *Example of weak entity:* Phone Call (see below) is an example of a weak entity because a phone call must be placed by a PERSON and thus, an instance of PHONE CALL cannot exist without an instance of PERSON. In this simple example, PHONE CALL is related to only one other entity type, Thus, it is not necessary to show the identifying relationship; however, if this data model were ever expanded so that PHONE CALL related to other entity types, it is good practice to always indicate the identifying relationship.



12. *Degree of relationship definition & examples:*

The degree of a relationship is the number of entity types that participate in the relationship.

a) Unary (one entity type):

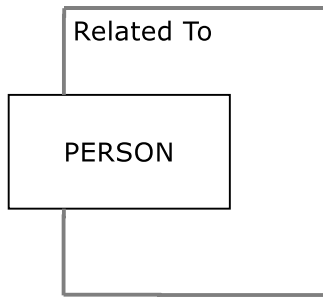

b) Binary (two entity types):



c) Ternary (three entity types):

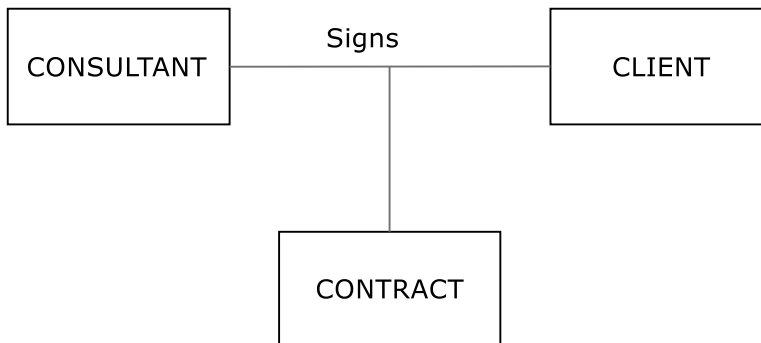

13. *Attribute examples:*

- a. Derived – distance (rate x time); both rate and time could be stored, and then when the data is retrieved from the database (e.g., at run-time) the distance could be calculated from the already-stored data elements
- b. Multivalued – spoken language; a person can speak more than one language
- c. Atomic – Social Security Number; this United States National Identification number cannot be broken down into component parts
- d. Composite – Phone Number; a phone number is often broken down into country code, area code, and the rest of the phone number
- e. Required – First Name or Last Name of a person; although Middle Initial may be optional, a person's First Name and Last Name are generally necessary for business records in a database so the person can be appropriately addressed
- f. Optional – Middle Initial; a person's middle initial may be optional for identification purposes or also because some people may not have a middle name

14. *Examples of relationships:*

(a) Ternary

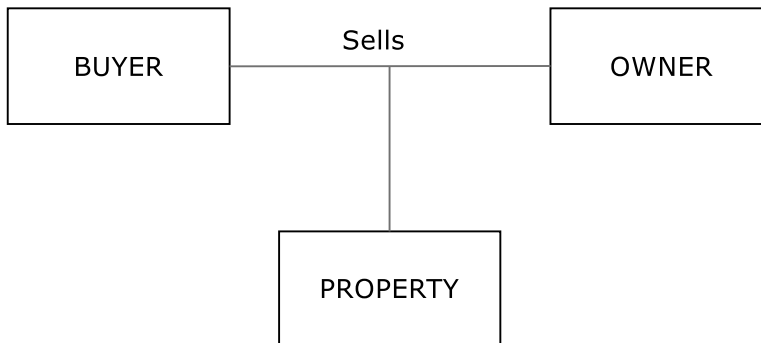

The sale of a property is a simultaneous relationship among the PROPERTY, a BUYER, and an OWNER entity types. This “event” cannot be modeled appropriately with three binary relationships; any one of the three binary relationships (PROPERTY-BUYER; BUYER-OWNER; and PROPERTY-OWNER) is missing an essential element of the sale.

(b) Unary

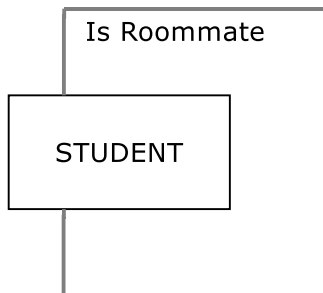

In an on-campus dormitory/apartment situation, this diagram shows a recursive/unary relationship among instances of the STUDENT entity type. This notation indicates only the current roommate situation between instances of the STUDENT entity type.

15. Effective (or effectivity) dates:

Effective (or effectivity) dates are used in a data model when the organization wishes to record historical data, rather than just the current instance. A few examples might include the effective date of a product price or service rate. Another example might be the start and end date of an advisor’s assignment to work with a student at a university (see E-R segment below, which includes a multivalued composite attribute Advisor).

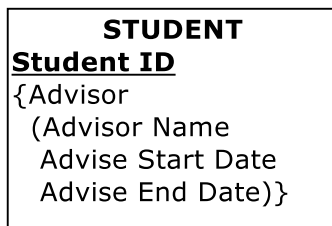

16. *Special guidelines for naming relationships:*

- A relationship name should always be a verb phrase and should state the action taken,

- as opposed to the result of the action taken.
- Use descriptive, powerful verb phrases as opposed to vague names.
17. *The relationship definition should also explain the following:*
- any optional participation
 - the reason for any explicit maximum cardinality
 - any mutually exclusive relationships
 - any restrictions on participation in the relationship
 - the extent of history that is kept in the relationship
 - whether an entity instance involved in a relationship instance can transfer participation to another relationship instance
18. *Manages relationship in Figure 12a:*
- Presently, the cardinality is one-to-many. One possible scenario is an employee who is supervised by more than one manager. This would make the cardinality many-to-many. Another possibility (although very rare in practice) is that the employee is supervised by one manager, and the manager only supervises one employee. This would result in a one-to-one cardinality. If we take time/history into consideration, the idea of someone being managed currently versus never being managed could affect the cardinality. As we can see here, you cannot always tell what the business rule is by looking at the ERD. These possible scenarios will need to be discussed with the end user to determine the “correct” modeling representation for the business rules at this organization.
19. *Entity type vs. Entity instance:*
- An entity type can be thought of as a template, defining all of the characteristics of an entity instance. For example, “student” would be an entity type, whereas *you* are an instance of “student.”
20. *Conversion of ternary relationship into an associative entity:*
- Converting a ternary relationship into an associative entity is recommended for two main reasons: (1) research has shown that participation/cardinality constraints cannot be accurately represented for a ternary relationship with current notation; and (2) most E-R diagramming tools cannot represent ternary relationships. By converting a ternary relationship into an associative entity with three mandatory binary relationships, a data modeler can accurately represent the participation/cardinality constraints although there is a risk that the meaning/semantics of the original ternary relationship is lost with this solution.

Answers to Problems and Exercises1. *Cellular Operator Database Figure 2-23 questions:*

- a. Can a customer have an unlimited number of plans?

Yes. A Customer may be responsible for 0, 1, or many Plans.

- b. Can a customer exist without a plan?

Yes. The minimum cardinality of the Belongs relationship from the Customer to the Plan states that a Customer may exist without a Plan (the minimum cardinality is 0).

- c. Is it possible to create a plan without knowing who the customer is?

No. The minimum cardinality of both the “responsible for” and “belongs” relationships between Plan and Customer states that at least one Customer must be related to a Plan.

- d. Does the operator want to limit the types of handsets that can be linked to a specific plan type?

Yes, the cellular operator requires that a Handset (that is a particular type and a particular operating system) is linked to one Plan (that is a particular type of plan). This business rule is to be implemented in this design by indirectly requiring that a Plan Type has 0:M Plans, and each Plan is associated with certain Handsets, and each Handset is of some Handset Type. A given Plan Type is related to Handset Type through the intermediary entity types in this design.

- e. Is it possible to maintain data regarding a handset without connecting it to a plan?

Yes. The minimum cardinality of the Includes relationship between Plan and Handset states that a Handset may be included in 0 or 1 plan. The 0 minimum cardinality means that we can track data about the handset even if it is not connected to a plan; the Handset has optional participation in the Includes relationship with Plan.

- f. Can a handset be associated with multiple plans?

No. The minimum cardinality of the Includes relationship between Plan and Handset states that a Handset may be included in 0 or 1 plan, not multiple plans.

- g. Assume a handset type exists that can utilize multiple operating systems. Could this situation be accommodated within the model included in Figure 2-23?

No. The current model shows that a handset type is associated with one and only one operating system.

- h. Is the company able to track a manufacturer without maintaining information about its handsets?

Yes. The minimum cardinality of the relationship between Manufacturer and Handset Type indicates that we can track data about a Manufacturer even if we have no (or zero) Handset Types in our database.

- i. Can the same operating system be used on multiple handset types?

Yes. The maximum cardinality on the relationship between Operating System and Handset Type indicates that an Operating System may be used on 0, 1, or many Handset types.

- j. There are two relationships between Customer and Plan. Explain how they differ.

The Responsible For relationship is an overall 1:M relationship between Customer and Plan. A Customer can be responsible for 0, 1, or many Plans yet any one Plan will be linked to only 1 Customer for responsibility purposes. The Belongs relationship is an overall M:M relationship that permits the linking of multiple customers to a single plan, as in the case of family members being part of a particular plan or different plans.

- k. Characterize the degree and the cardinalities of the relationship that connects Customer to itself. Explain its meaning.

The “Family Member” relationship that connects Customer to itself has a degree of 1 (unary). It permits the tracking of each family member as a Customer. Any Customer may be a Family Member of 0, 1, or many Customer(s); as a Family Member Customer, the Customer may be linked to 0 or 1 Customer.

- l. Is it possible to link a handset to a specific customer in a plan with multiple customers?

No, this is not possible according to the current model. However, the current model could be adjusted to create an Associative Entity to track the particular Customer instance with a particular Plan instance that is then associated with a particular Handset. This suggested extension to the current model also permits a design that will easily extend the database’s ability to track additional data about the particular Customer instance with a particular Plan instance.

- m. Can the company track a handset without identifying its operating system?

No. The minimum cardinality of the relationship between Handset Type and Operating System is 1 and only 1; the minimum of 1 is a mandatory participation for the Handset Type with the Operating System.

2. For each of the descriptions below, perform the following tasks:

- i) Identify the degree and cardinalities of the relationship.
 - ii) Express the relationships in each description graphically with an E-R diagram
- a. A book is identified by its ISBN (International Standard Book Number), and it has a title, a price, and a date of publication. It is published by a publisher, each of which has its own ID number and a name. Each book has exactly one publisher, but one publisher typically publishes multiple books over time.

(2.a.i) This relationship is a degree of 2 (binary). This relationship is one-to-many from Publisher to Book.

(2.a.ii)

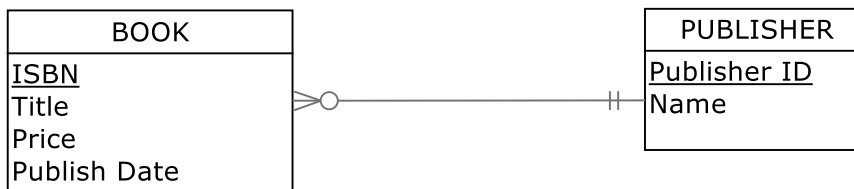

Note: This solution assumes that we have a reason to track a Publisher even if it does not yet have a Book published.

- b. A book (see above in 2.a) is written by one or multiple authors. Each author is identified by an author number and has a name and date of birth. Each author has either one or multiple books; in addition, occasionally data are needed also regarding prospective authors who have not yet published any books.

(2.b.i) This relationship is a degree of 2 (binary). This relationship is many-to-many from Author to Book.

(2.b.ii)

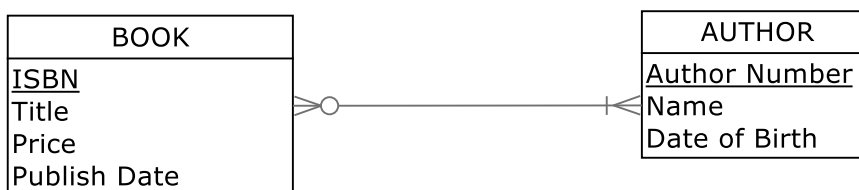

- c. In the context specified above in 2.a and 2.b, better information is needed regarding the relationship between a book and its authors. Specifically, it is important to record the percentage of the royalties that belong to a specific author, whether or not a specific author is a lead author of the book, and each author's position in the sequence of the book's authors.

(2.c.i) This relationship is a degree of 2 (binary). This relationship is many-to-many from Author to Book.

(2.c.ii)

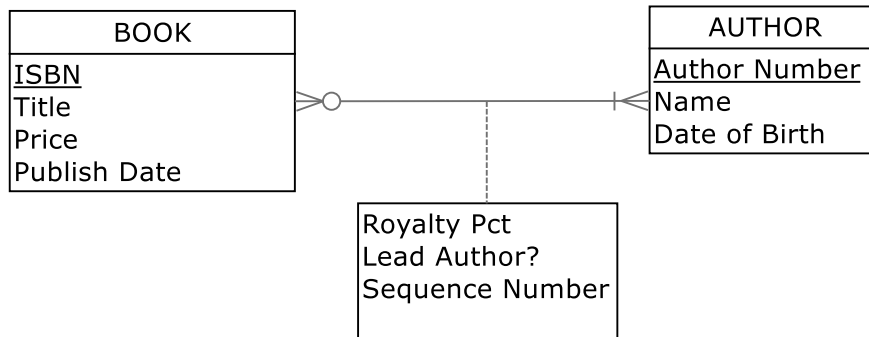

- d. A book (see 2.a above) can be part of a series, which is also identified as a book and has its own ISBN number. One book can belong to several sets, and a set consists of at least one but potentially many books.

(2.d.i) This relationship is a degree of 1 (unary). This relationship is many-to-many.

(2.d.ii) This solution assumes that “series” and “sets” are synonymous terms. The question does not require that a series have any special attributes or distinguishing features, so it can be represented in the data model like any other Book instance and identified by ISBN.

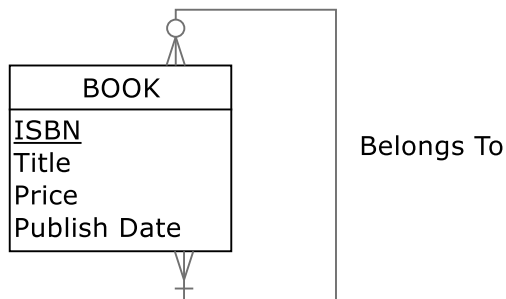

- e. A piano manufacturer wants to keep track of all the pianos it makes individually. Each piano has an identifying serial number and a manufacturing completion date. Each instrument represents exactly one piano model, all of which have an identification number and a name. In addition, the company wants to maintain information about the designer of the model. Over time, the company often manufactures thousands of pianos of a certain model, and the model design is specified before any single piano exists.

(2.e.i) These relationships have a degree of 2 (binary). These relationships are one-to-many.

(2.e.ii)

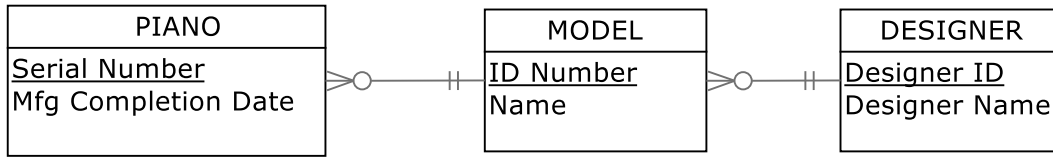

- f. A piano manufacturer (see 2.e above) employs piano technicians who are responsible for inspecting the instruments before they are shipped to the customers. Each piano is inspected by at least two technicians (identified by their employee number). For each separate inspection, the company needs to record its date and a quality evaluation grade.

(2.f.i) This relationship is a degree of 2 (binary). This relationship is many-to-many.

(2.f.ii)

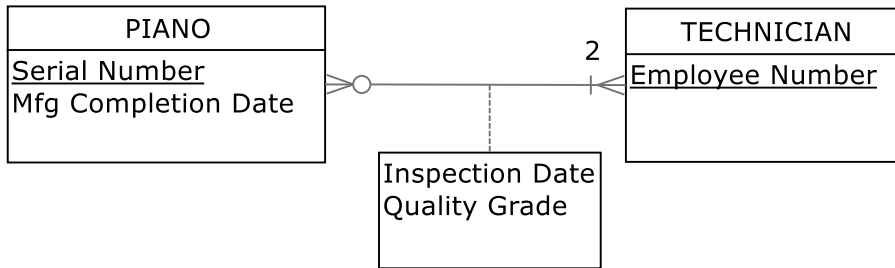

- g. The piano technicians (see 2.f above) have a hierarchy of reporting relationships: some of them have supervisory responsibilities in addition to their inspection role and have multiple other technicians report to them. The supervisors themselves report to the chief technician of the company.

(2.g.i) This relationship is a degree of 1 (unary). This relationship is one-to-many.

(2.g.ii) Because the chief technician is not represented as a separate entity type, that person does not have a supervisor. This, in turn, leads to the 0 minimum cardinality on the 1 side of the unary relationship.

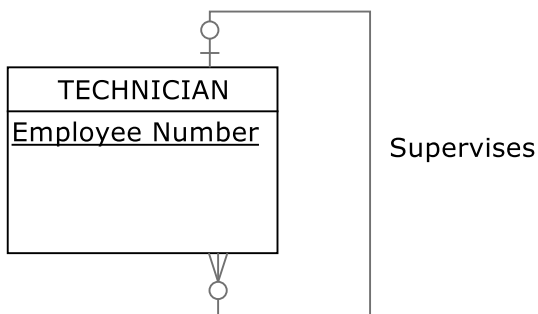

- h. A vendor builds multiple types of tablet computers. Each type has a type identification number and a name. The key specifications for each type include amount of storage space and display type. The company uses multiple processor types, exactly one of which is used for a specific tablet computer type; obviously, the same processor can be used in multiple types of tablets. Each processor has a manufacturer and a manufacturer's unique code that identifies it.

(2.h.i) This relationship is a degree of 2 (binary). This relationship is many-to-many.

(2.h.ii)

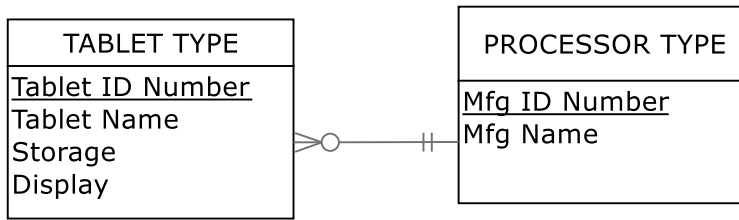

- i. Each individual tablet computer manufactured by the vendor (see 2.h above) is identified by the type identification number and a serial number that is unique within the type identification. The vendor wants to maintain information about when each tablet is shipped to a customer.

(2.i.i) These relationships are a degree of 2 (binary). These relationships are one-to-many. If, over time, shipment of a tablet computer to multiple customers (e.g., as in a refurbished unit) is possible, the Tablet Computer – Customer relationship would become many-to-many and the Shipping Date attribute would become an attribute of that M:N relationship.

(2.i.ii)

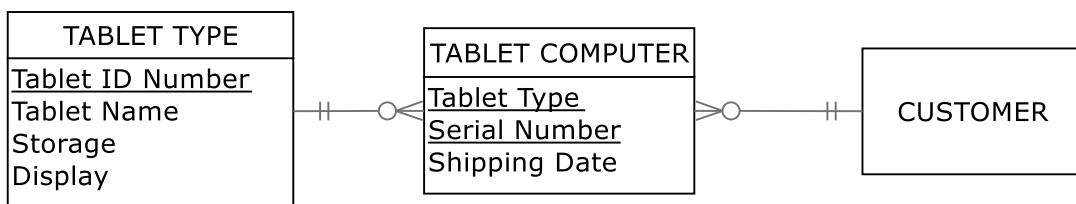

- j. Each of the tablet computer types (see 2.h above) has a specific operating system. Each technician the company employs is certified to assemble a specific tablet type – operating system combination. The validity of a certification starts on the day the employee passes a certification examination for the combination, and the certification is valid for a specific period of time that varies depending on tablet type–operating system combination.

(2.j.i) This relationship is a degree of 2 (binary). This relationship is many-to-many.

(2.j.ii) Based on the limited situation description, it appears that there is no need to model a separate entity type for Operating System. If the situation required additional data about the Operating System and the Technician's certification for this element, the diagram would need to be revised accordingly.

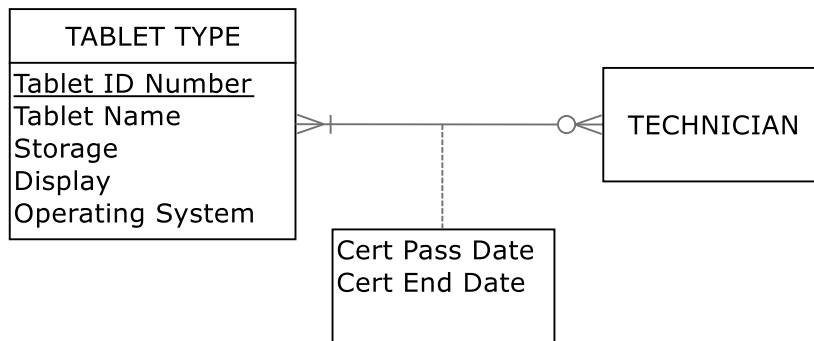

3. Each answer refers to Figure 2-21 found in the chapter text.
- a) Where is a unary relationship, what does it mean, and for what reasons might the cardinalities on it be different in other organizations?

A unary relationship is shown with the EMPLOYEE entity; An EMPLOYEE Supervises 0:M EMPLOYEEs, An EMPLOYEE Is Supervised By 0:1 EMPLOYEE. This relationship tells us that we can determine which employees are supervised by another employee, as well as determine which employees are supervisors in this company.

In other organizations, there may be different policies regarding employee supervision that could cause the data relationships among EMPLOYEE instances to be different. For instance, another company might allow an employee to have multiple supervisors (e.g., in an organization with a matrix structure).

- b) Why is Includes a one-to-many relationship and why might this ever be different in some other organization?

Includes is a one-to-many (1:M) relationship because of the business rules that PVFC has in place: “a product line may group any number of products but *must group at least one product*; and each product *must belong to exactly one product line*.” Another organization may have other business rules that could permit a product being assigned to more than one product line (changing Includes to a M:N relationship). Alternatively, another organization might also show Includes as a (1:M) overall relationship but might permit the establishment of a PRODUCT LINE without identifying PRODUCTS that belong to this group (e.g., thus permitting an optional minimum cardinality on the PRODUCT side of the Includes relationship).

- c) Does Includes allow for a product to be represented in the database before it is assigned to a product line (e.g., while the product is in research and development)?

No, Figure 2-21 shows that the PRODUCT must be Included in at least 1 PRODUCT LINE by the mandatory 1 and only 1 cardinality notation near the PRODUCT LINE portion of the Includes relationship line. The cardinality notation would have to be changed to show optional one cardinality in order to represent the research and development situation.

- d) Suppose there is a rating of the competency for each skill an employee possesses, where in the data model would we place this rating?

The Has Skill associative entity, which associates a single instance of a SKILL with a single instance of an EMPLOYEE, would permit the tracking of a competency rating for each skill in which an employee has competence.

- e) What is the meaning of the Does Business In associative entity and why does each Does Business In instance have to be associated with exactly one TERRITORY and CUSTOMER?

The Does Business In associative entity associates a single instance of a TERRITORY with a single instance of a CUSTOMER for the overriding M:N Does Business In relationship between TERRITORY and CUSTOMER. Each Does Business In instance must be related to exactly one TERRITORY and one CUSTOMER because the business rules of PVFC indicate that sales territories have been established for its customers. In particular, the rules are: *a TERRITORY has one-to-many CUSTOMERs; and a CUSTOMER may do business in 0:M TERRITORIES.* When converting this M:N relationship on the ERD, the cardinalities near the originating entities will always be mandatory one, indicating the exactly one relationship with each entity's instances and the associative entity's instance.

- f) In what way might Pine Valley change the way it does business that would cause the Supplies associative entity to be eliminated and the relationships around it to change?

According to current business practice at PVFC, each RAW MATERIAL is provided by 1 or more VENDORS and a VENDOR supplies 0, 1, or many RAW MATERIALs and this is represented by the Supplies associative entity. The PVFC could consider entering into exclusive supplier arrangements with particular vendors such that an instance of RAW MATERIAL is supplied by only 1 VENDOR. If that situation should occur, then the overall relationship between RAW MATERIAL and VENDOR would change to 1:M (instead of M:N) and the Supply Unit Price attribute could become part of the RAW MATERIAL entity instance; the Supplies associative entity would no longer need to be on the ERD.

4. Analysis of Figure 2-21:

- 4.1. Entities PRODUCT, PRODUCT LINE; relationship Includes
- 4.2. Entities CUSTOMER, ORDER; relationship Submits
- 4.3. Entities ORDER, PRODUCT; associative entity ORDER LINE
- 4.4. Entities CUSTOMER, TERRITORY; associative entity DOES BUSINESS IN
- 4.5. Entities SALESPERSON, TERRITORY; relationship Serves
- 4.6. Entities PRODUCT, RAW MATERIAL; relationship Uses
- 4.7. Entities RAW MATERIAL, VENDOR; relationship Supplies
- 4.8. Entities WORK CENTER, PRODUCT; associative entity PRODUCED IN
- 4.9. Entities EMPLOYEE, WORK CENTER; associative entity WORKS IN
- 4.10. Entity EMPLOYEE; relationship Supervises, Is Supervised By

5. Use of CASE or drawing tool: Student answers will vary based on the CASE or drawing tool that is used and their personal experiences. The answers should describe their experiences with the CASE or drawing tool in terms of the requirements of the E-R notation used in the chapter. Expect to see students make reference to noting identifiers, using associative entities,

using cardinality constraints properly, indicating required vs. optional attributes, and noting derived/composite/multivalued attributes.

6. *ER diagrams in Figure 2-24:*

6a) The ERD for City B does not (nor does any ERD) tell us why the cardinality is 1:M. The more restrictive cardinality for City B could be due to a business rule that they want to maintain only current volunteers but it could also be due to only tracking the agency for which the volunteer works the most hours of assistance. More detailed discussions would need to be held with the end users to properly document this business rule; notes should be added to the diagram to depict the appropriate business rule.

6b) The ERD for City A shows that a volunteer may assist one, none, or several agencies.

6c) The native notation used in ERDs does not show whether membership in a relationship can change (i.e., whether a volunteer can change agencies or whether an agency can change its volunteers). Some DBMSs can be told whether membership can change or not, and special notation or textual notes can be added to an ERD to state such business rules. The minimum cardinality next to Agency does address whether a Volunteer must always be associated with an Agency to exist in the database, but none of the cardinalities control whether linkages between specific agencies and volunteers can change. More detailed discussions would need to be held with the end users to properly document this business rule; notes should be added to the diagram to depict the appropriate business rule.

	City A	City B	Can't Tell
a. Which city maintains data about only those volunteers who currently assist agencies?			X
b. In which city would it be possible for a volunteer to assist more than one agency?	X		
c. In which city would it be possible for a volunteer to change which agency or agencies she assists?			X

7. *ERD for Student situation:*

Note: Assume Student Name is unique and available to be used as the identifier. Typically, Student Name would not be used as an identifier.

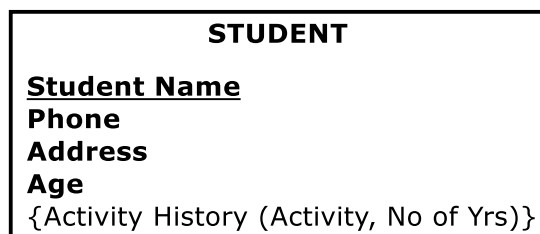

8. *Associative entities vs. Weak entities?*

A weak entity requires the presence of another entity type; the weak entity does not exist independently from the other entity type and has no business meaning in the ERD without the other entity type. A weak entity will not have its own identifier, but will have a partial identifier attribute that will later be combined with the identifier of its strong entity owner to create a full identifier.

An associative entity is an entity type that associates the instances of one or more entity types and contains attributes specific to the relationship between those entity instances. An associative entity generally has independent business meaning to end users and can be identified with a single-attribute identifier. If an associative entity meets these conditions, then it would not be considered a weak entity.

9. *Figure 2-21 associative entities:*

DOES BUSINESS IN: between TERRITORY and CUSTOMER

Although this entity has no attributes and no independent meaning, it is the only way that Visio can represent the M:N relationship between TERRITORY and CUSTOMER.

ORDER LINE: between PRODUCT and ORDER

This relationship has an attribute: Ordered Quantity that reflects the amount of product on each line of the order by the customer. It has independent meaning on the Customer's Order.

USES: between PRODUCT and RAW MATERIAL

This relationship has one attribute, Goes Into Quantity. It also may have independent meaning, although there is no obvious independent identifier.

SUPPLIES: between RAW MATERIAL and VENDOR

Since there is an attribute on this entity and it can have independent meaning, it might be a good candidate to convert to an associative entity.

PRODUCED IN: between WORK CENTER and PRODUCT

Although this entity has no attributes and no independent meaning, it is the only way that Visio can represent the M:N relationship between WORK CENTER and PRODUCT.

WORKS IN: between WORK CENTER and EMPLOYEE

Although this entity has no attributes and no independent meaning, it is the only way that Visio can represent the M:N relationship between WORK CENTER and EMPLOYEE.

HAS SKILL: between EMPLOYEE and SKILL

Although this entity has no attributes and no independent meaning, it is the only way that Visio can represent the M:N relationship between SKILL and EMPLOYEE.

There are so many associative entities because there are many M:N relationships that have independent meaning and because Visio's templates cannot represent M:N relationships.

10. *ERD for Figure 2-25 Grade Report:* Student ID was chosen as the identifier for the STUDENT entity type as it is likely unique. Course ID was chosen as the identifier for the COURSE entity type as it is likely unique. Instructor Name was chosen as the identifier for the INSTRUCTOR entity type and it is assumed to be unique—should discussions during analysis work prove otherwise, it may be wise to create either (a) a composite identifier comprised of Instructor Name and Location, or (b) a new attribute Instructor ID that will be a unique number which can serve as an identifier (the latter option would, in practice, be the most likely one).

Note: The addition of Semester and Year attributes on the Registers for relationship allows this diagram (and resulting database) to reflect multiple semesters of data.

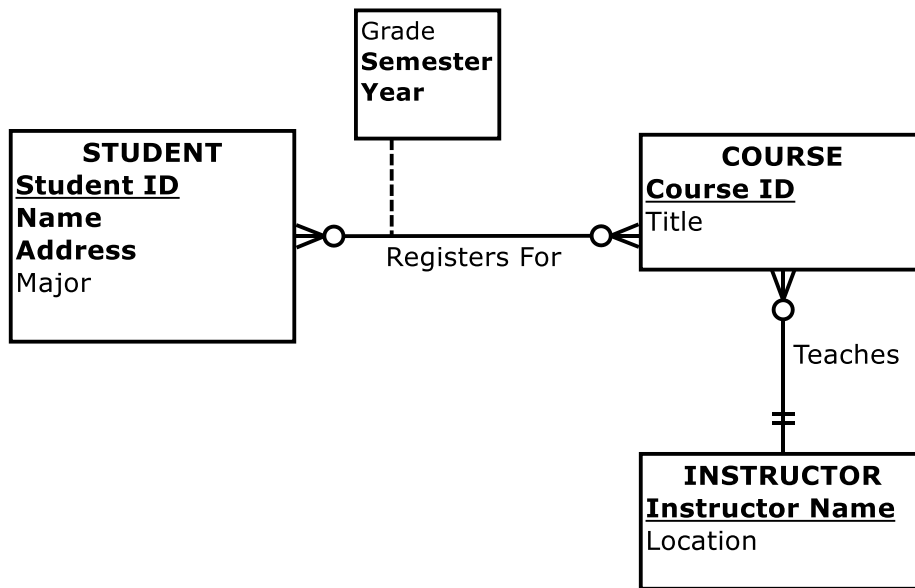

11. **Note:** attributes are omitted from the ERD solutions for this Problem and Exercise in order to save space in the Instructor’s Manual.

a. Figure 2-5



b. Figure 2-10a

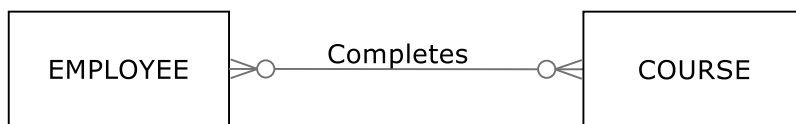

c. Figure 2-11b



d. Figure 2-12 (all parts)

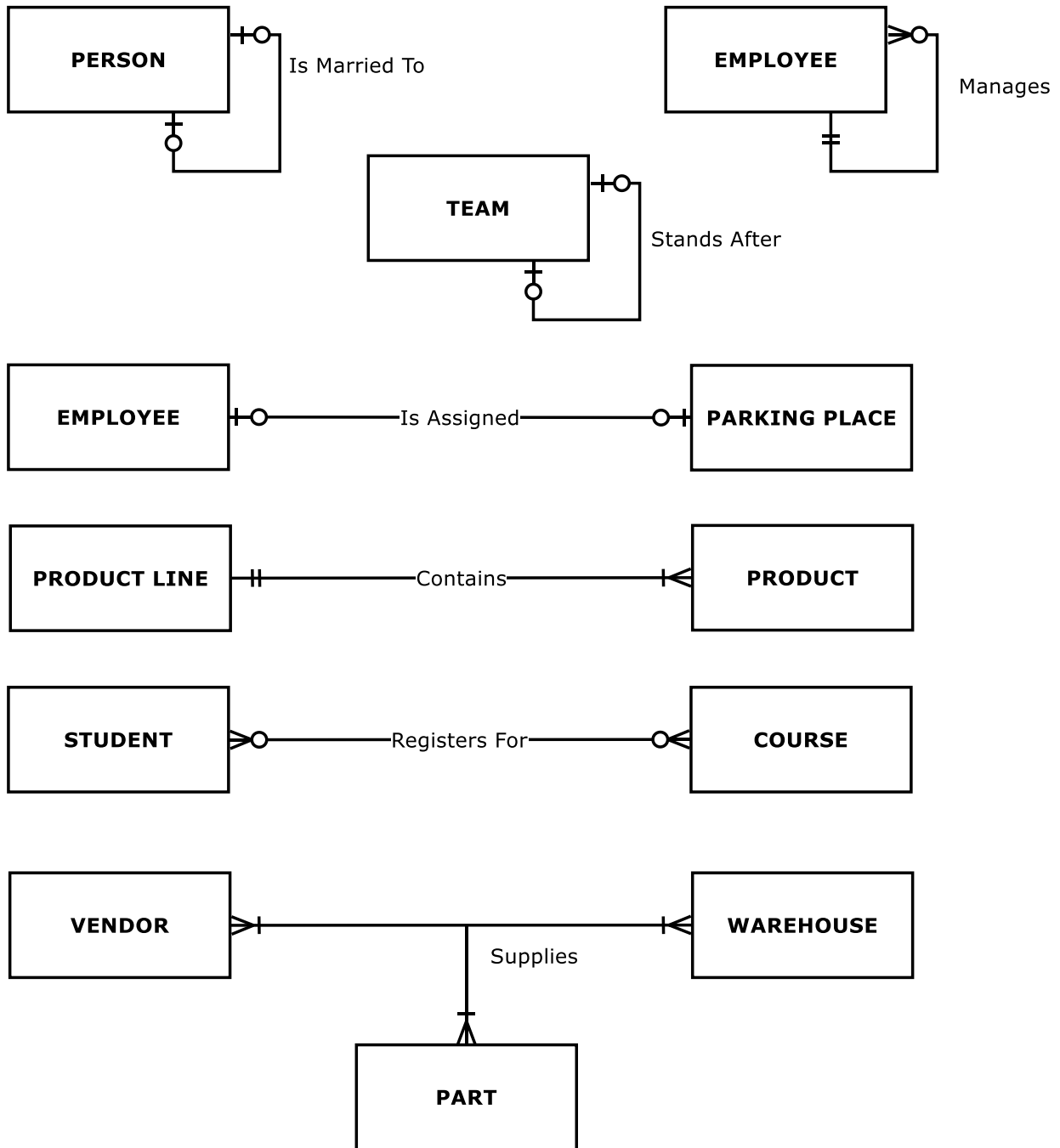

e. Figure 2-13c

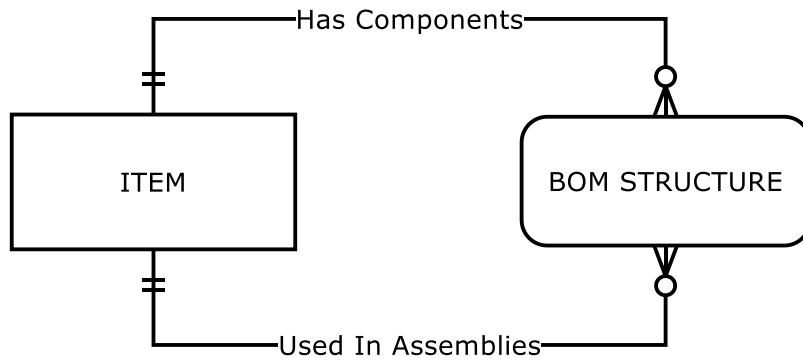

f. Figure 2-14

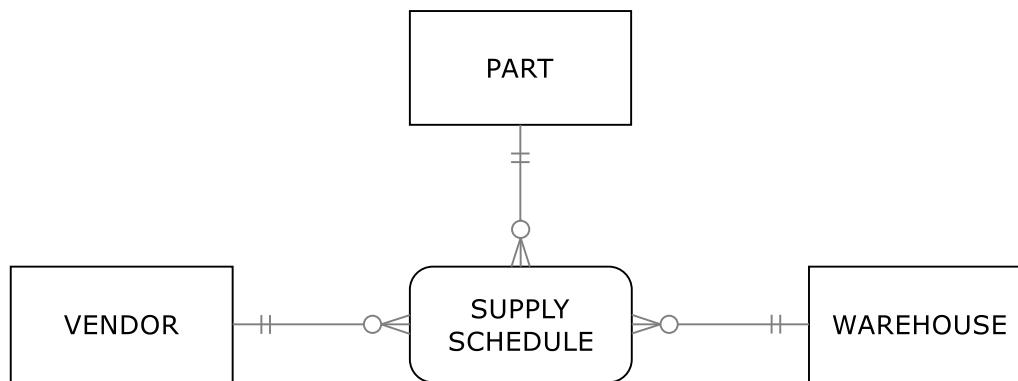

12. Is Married To relationship with time variations:

Diagram Notes for Problem & Exercise 12.d:

- This solution presumes that Marriage Date is a partial identifier of the MARRIAGE entity; a full composite identifier will include Marriage Date and the two Person IDs involved in the marriage. The solution also assumes that the same two people do not get married, divorced, and re-married on the same date. Adding a Marriage Time attribute (also a part of the identifier) would permit this situation to be covered by this model.
- An alternate solution would be to use a surrogate identifier of License No instead of the suggested composite identifier of Marriage Date and the two Person IDs for the MARRIAGE entity.

Problem & Exercise (a)

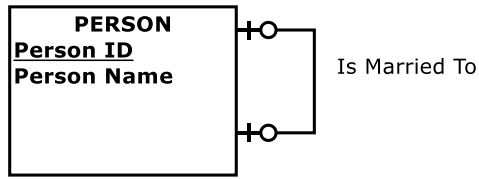

Problem & Exercise (b)

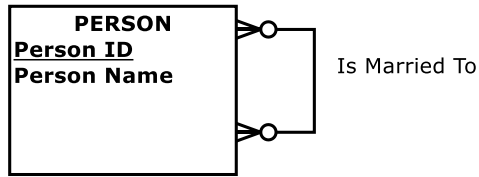

Problem & Exercise (c)

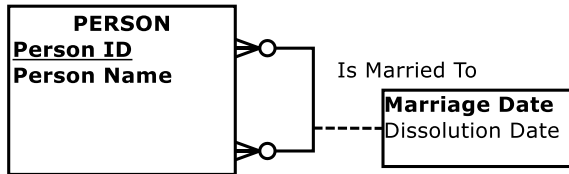

Problem & Exercise (d)

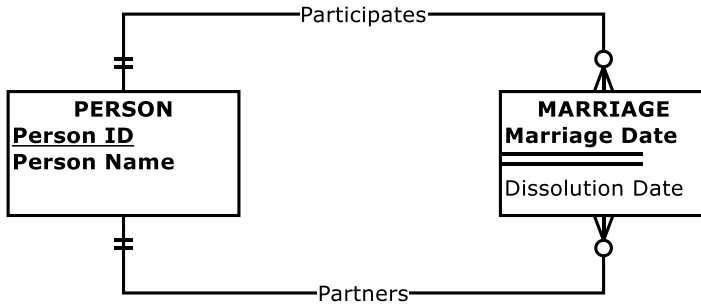

Problem & Exercise 12.e:

The solution in 12.d does not place any restrictions on the number of persons to whom any one person is simultaneously married, thus the 12.d solution is sufficient in representing the lack of legal restrictions regarding the number of marriage partners.

13. Figure 2-26 Student, Club, School situation:

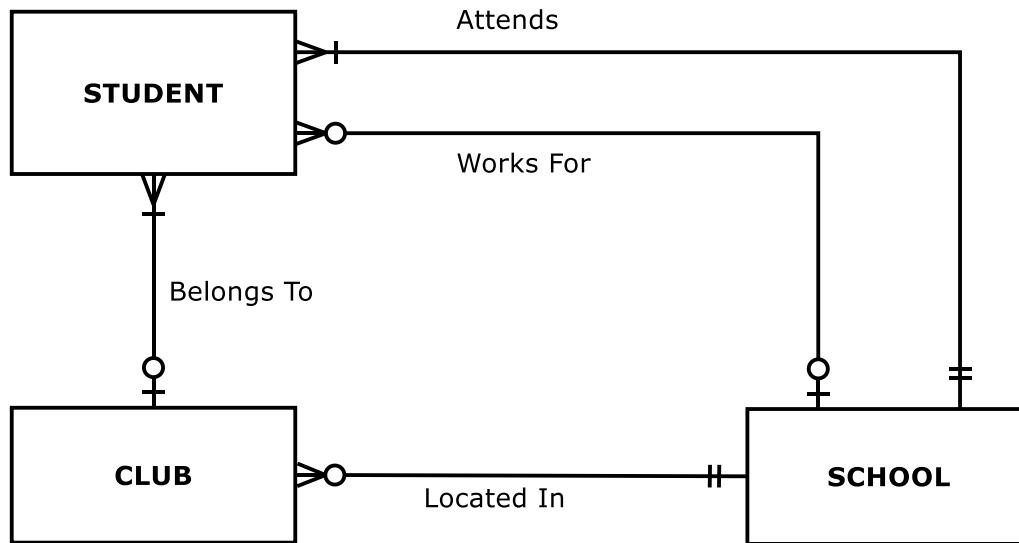

13.a. A STUDENT Works For 0:1 SCHOOL; A SCHOOL Employs 0:M STUDENTs

13.b. A STUDENT may belong to a CLUB only when located in the SCHOOL s/he Attends

13.c. Student answers may vary. Alternative solutions include:

- Since the STUDENT may not Work For a SCHOOL (the employment is optional), the Works For relationship is needed in the diagram in order to properly represent this business rule. This solution makes it harder for the database to enforce the business rule that a STUDENT works for the SCHOOL that s/he attends, but opens up the possibility that a STUDENT could Work For a SCHOOL that s/he is not currently attending.
- An alternative design would be to remove the Works For relationship, and add an attribute to STUDENT named Works that would have a binary (Y/N) value to represent whether or not the STUDENT instance is working for the SCHOOL s/he Attends. The advantage of this design is that it would enforce the business rule that a STUDENT can only Work For a SCHOOL that s/he is currently attending.

14. Figure 2-27 diagrams showing stock price history:

Note: Student answers may vary. The crux of the answer relies upon what the purpose of the E-R diagram is for the modeling situation and how end users in the organization “see” the situation. In particular, do people in the organization have a term for stock price and refer to it as its own concept?

If so, solution B may be the “better” way to model this situation. Instructors may also use solution B to demonstrate an issue related to view integration (topic in Chapter 4) where transitive dependencies emerge; solution B makes the model easy to expand so that stock prices may have relationships that do not directly involve the STOCK entity.

Solution A indicates that each STOCK has multiple prices and is well-suited to early discussions with end users about the data needs of a system. Solution B adds the precision of multiple STOCK PRICE entity instances occurring for each STOCK entity instance. Solution B indicates that STOCK PRICE is a weak entity whose instances do not exist independently

in the database without a corresponding STOCK entity instance. Solution B presents more precise detail of the data relationships that will likely be developed in the logical design of the database; this model may more closely resemble the relational model implementation of this design. Solution B also makes it easy to expand the model so that stock prices may have relationships with other entities that do not directly involve the STOCK entity.

15. Figure 2-11a (Modified):

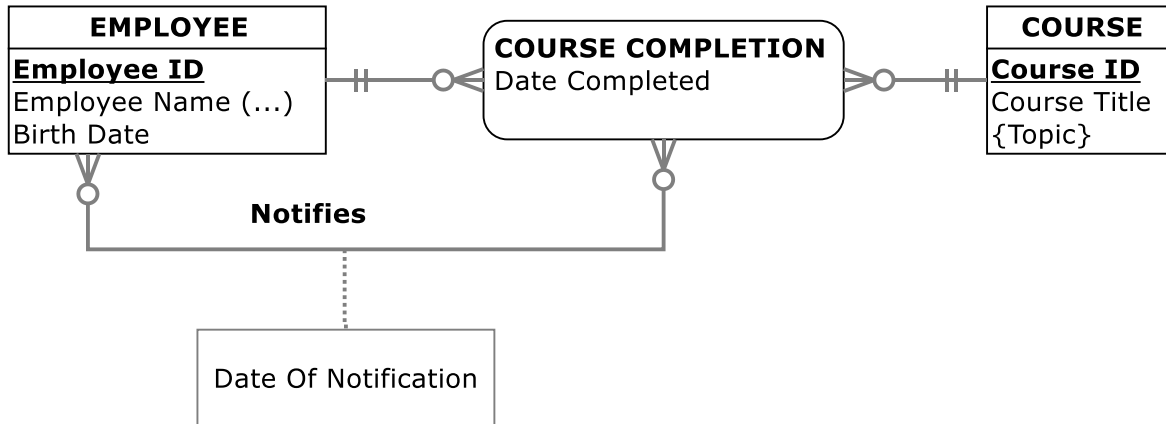

16.a. Salesperson Name (LName, MI, FName), Employee Name (LName, MI, FName) (see p. 42 of this manual)

16.b. There could be more than one product finish for a product, which could affect the price (see p. 43 of this manual).

16.c. Yes, this would be possible. For example, a customer could have more than one address.

17.a. ERD for Employee & Project situation:

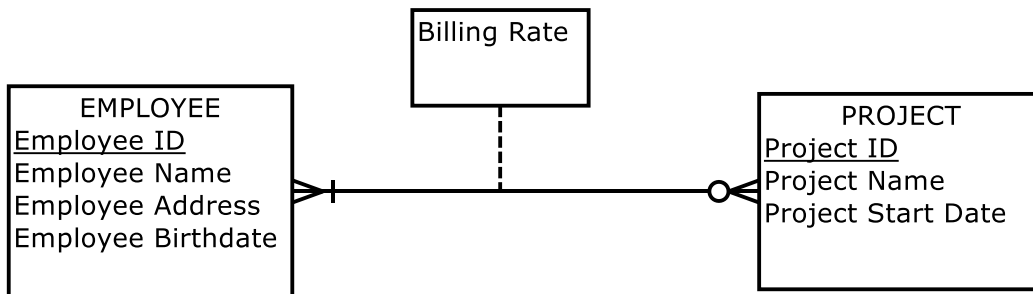

Yes, the attribute names do generally follow the guidelines for naming attributes.

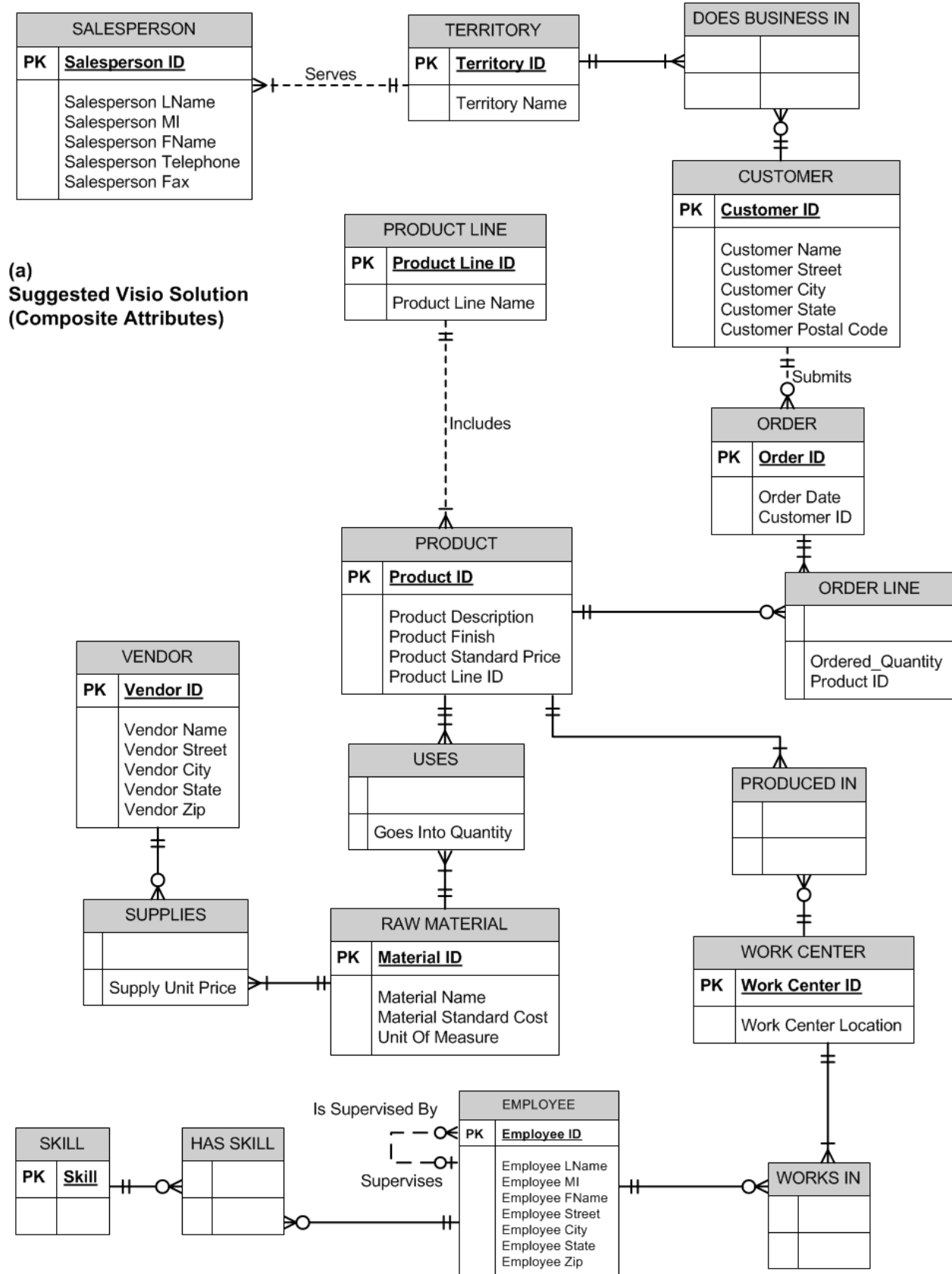

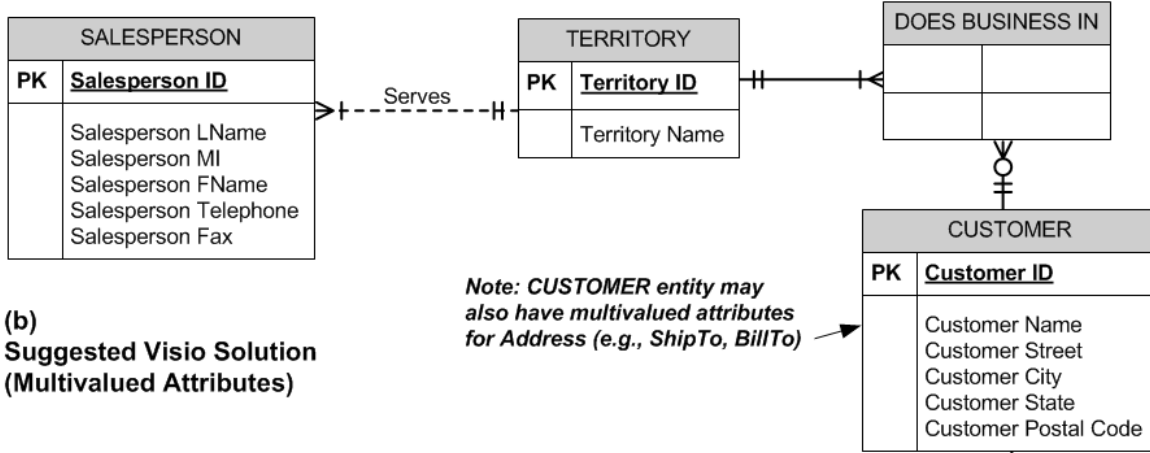

(b)
Suggested Visio Solution
(Multivalued Attributes)

Note: CUSTOMER entity may also have multivalued attributes for Address (e.g., ShipTo, BillTo)

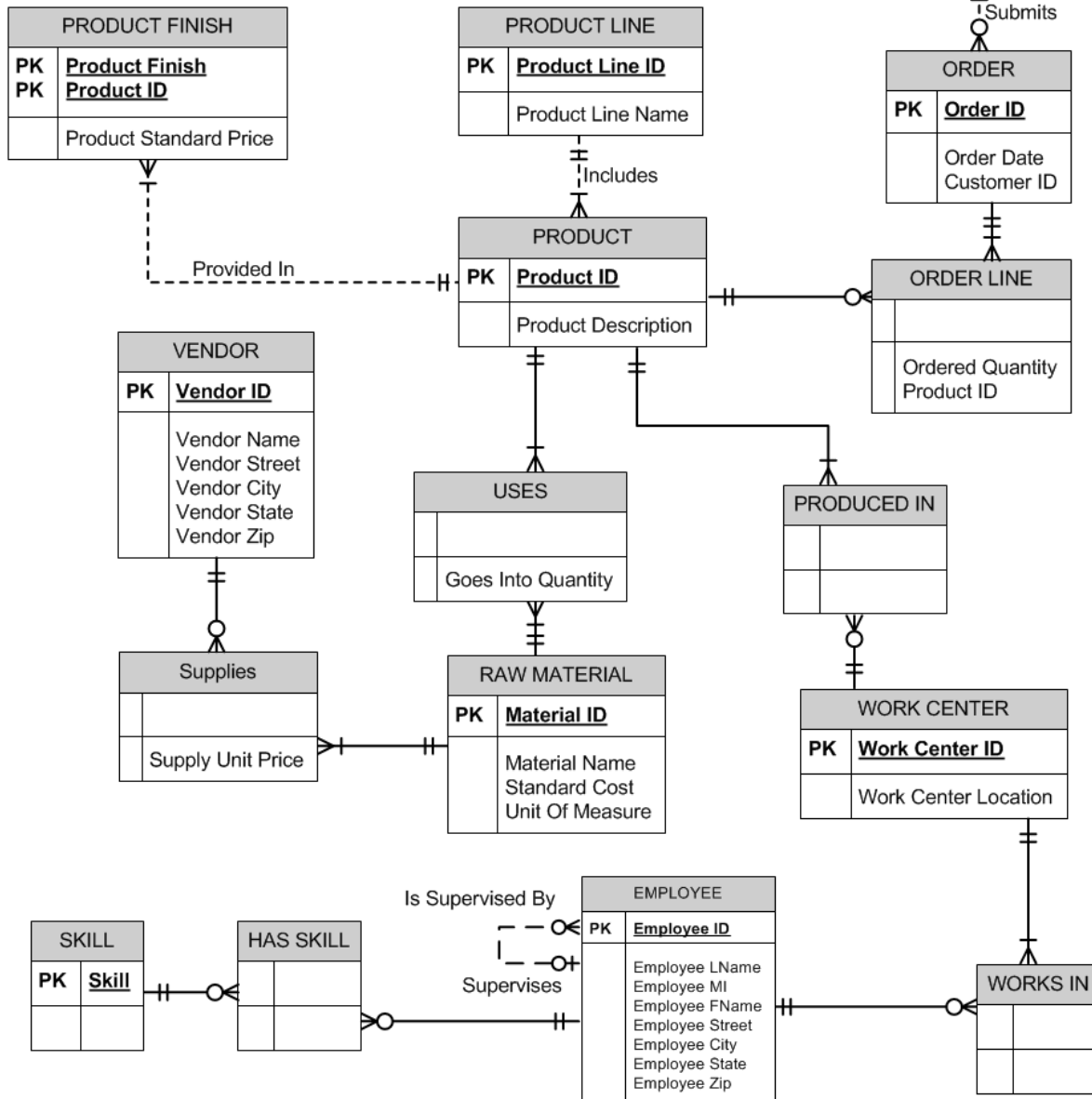

17.b. ERD for Chemist, Project, Equipment situation:

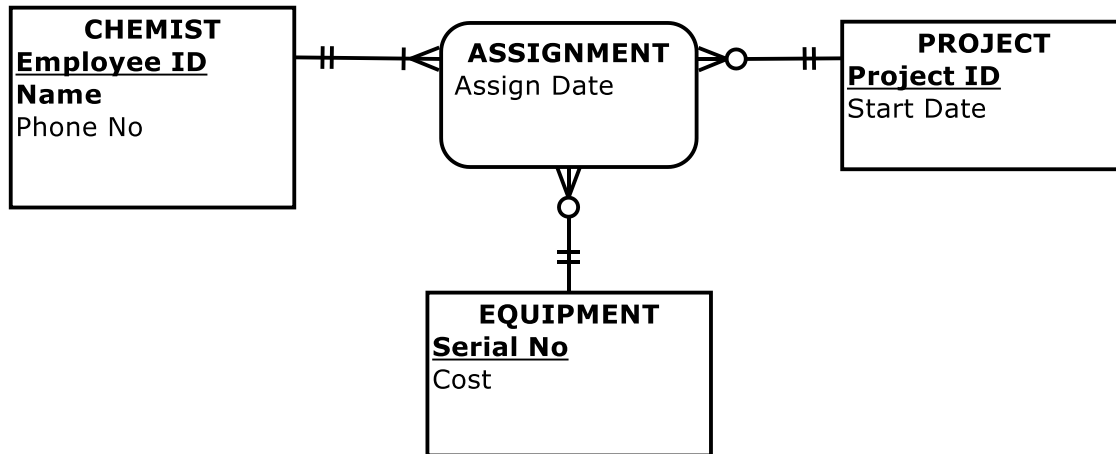

Assignment: All three entities participate in the Assigned relationship that is modeled as an associative entity Assignment, since the Assign Date for each CHEMIST's assignment to a particular project and equipment item must be tracked. However, EQUIPMENT and PROJECT do not need to participate in any assignments. All entities can have multiple assignments.

17.c. ERD for Course, Section situation:

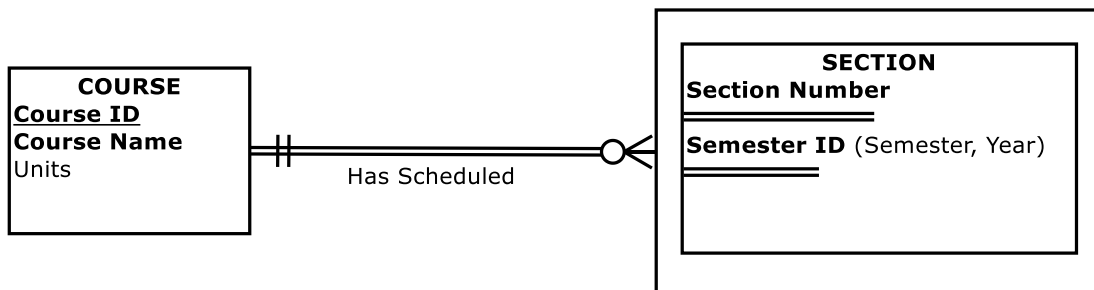

Diagram Notes for 17c: SECTION is modeled as a weak entity. It could have been modeled as a multivalued attribute; however, using a weak entity is better, since SECTION may have a relationship with another entity. A multivalued attribute could not be used to show this relationship.

17.d. ERD for Hospital situation:

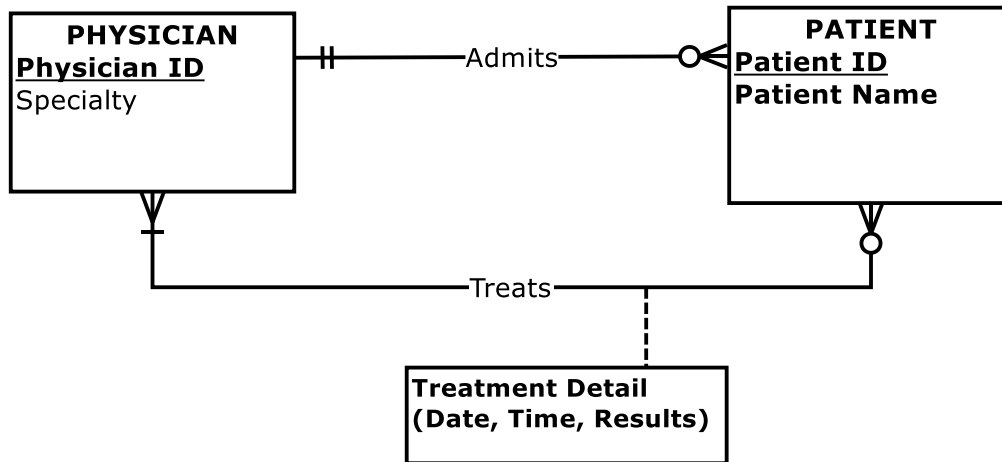
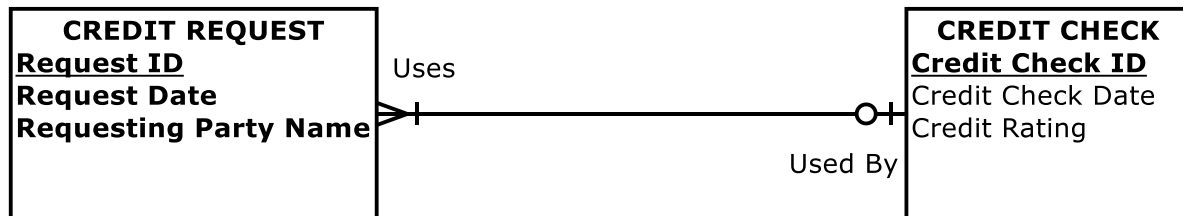
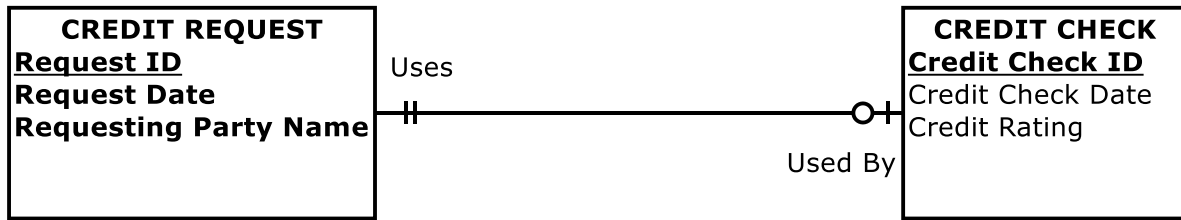

Diagram Notes for 17.d: Both Admits and Treats relationships were created since the patient could be treated by other PHYSICIANS in addition to the admitting PHYSICIAN. Hospital was not included as an entity in this case as there was insufficient information in the scenario write-up to indicate that the data model needed to allow for multiple hospitals (e.g., in the case of a large health-care organization). The current ERD does not allow for the tracking of multiple admissions over time by different physicians. The ERD would need a M:N relationship between PHYSICIAN and PATIENT in order to track that kind of data. If the date of admission needs to be tracked, under the circumstances of tracking multiple admissions over time, the ERD could be revised to show Date Admitted as an attribute of the M:N Admits relationship, just as Treatment Detail is an attribute of the Treats relationship. The ERD could also be revised to show ADMISSION and TREATMENT DETAIL associative entities (with corresponding attributes) instead of the M:N relationships currently discussed.

17.e. **First situation:** credit check can be used by more than one request.



Second Situation: CREDIT CHECK can only be used by 1 CREDIT REQUEST (2 entities)



Second Situation: CREDIT CHECK can only be used by 1 request (1 entity)

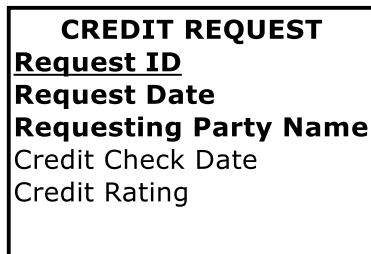

Using 1 entity type seems much simpler since the credit check and rating only apply to this credit request. However, Credit Check Date and Credit Rating will have blank values (null) until the credit check is received.

17.f. Starting point diagram:

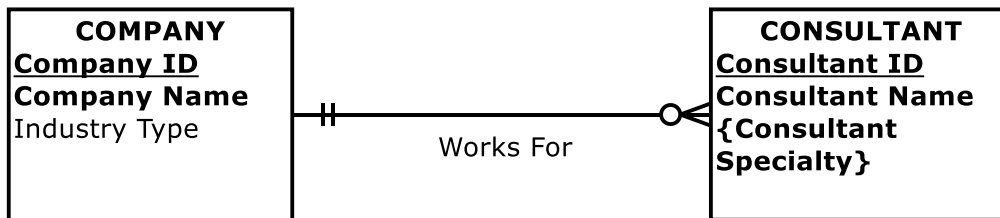

Situation 1 – Adding Hourly Rate attribute. This could be added to the CONSULTANT entity if the business rule is that a CONSULTANT Works for only one COMPANY at a time.

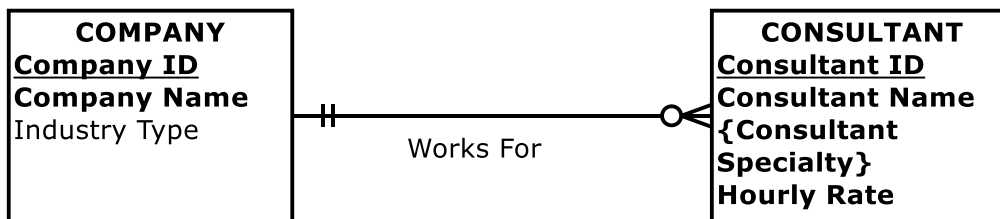

Situation 2 – Tracking a CONSULTANT’s contract. Notice that CONTRACT is added as another entity that participates in a binary relationship with COMPANY and a binary relationship with CONSULTANT. We have moved the Hourly Rate attribute to the CONTRACT entity, which permits a CONSULTANT to vary his/her Hourly Rate as a function of the particular

CONTRACT for a COMPANY. As only current CONTRACTs are tracked, an alternative solution would be to move the CONSULTANT attributes into the CONTRACT entity and eliminate the CONSULTANT entity from the model. The downside to this alternative solution is that Consultant Name and Consultant Specialty would occur redundantly in the CONTRACT entity instances.

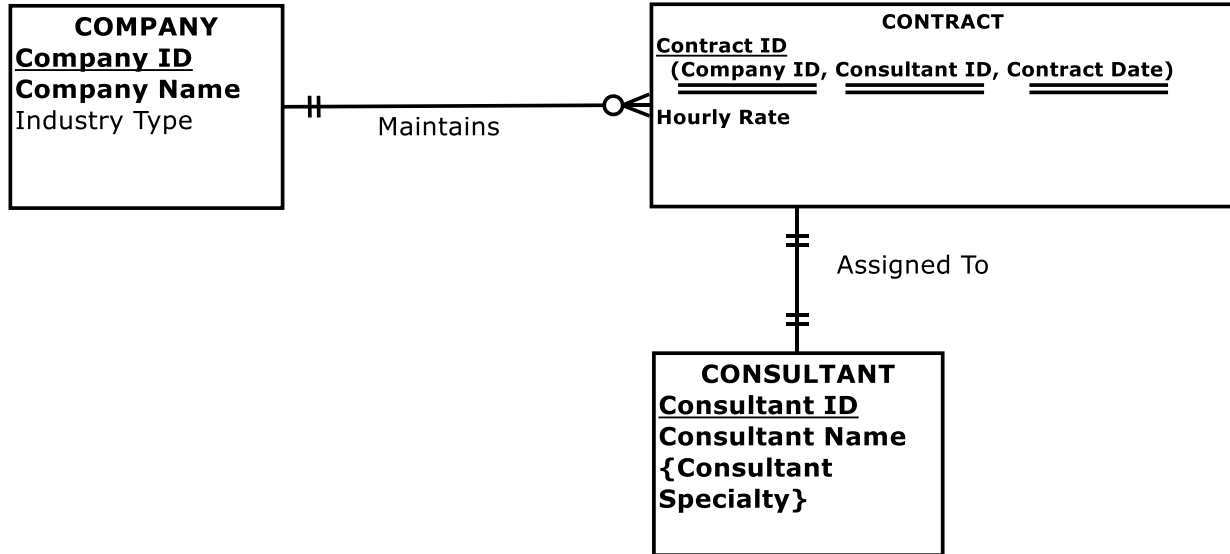

Situation 3 – Tracking historical CONTRACT information. We can create an associative entity for CONTRACT. We’ve also added Contract ID as a surrogate identifier that is a unique serial number (not a composite identifier, as shown in Situation 2 above).

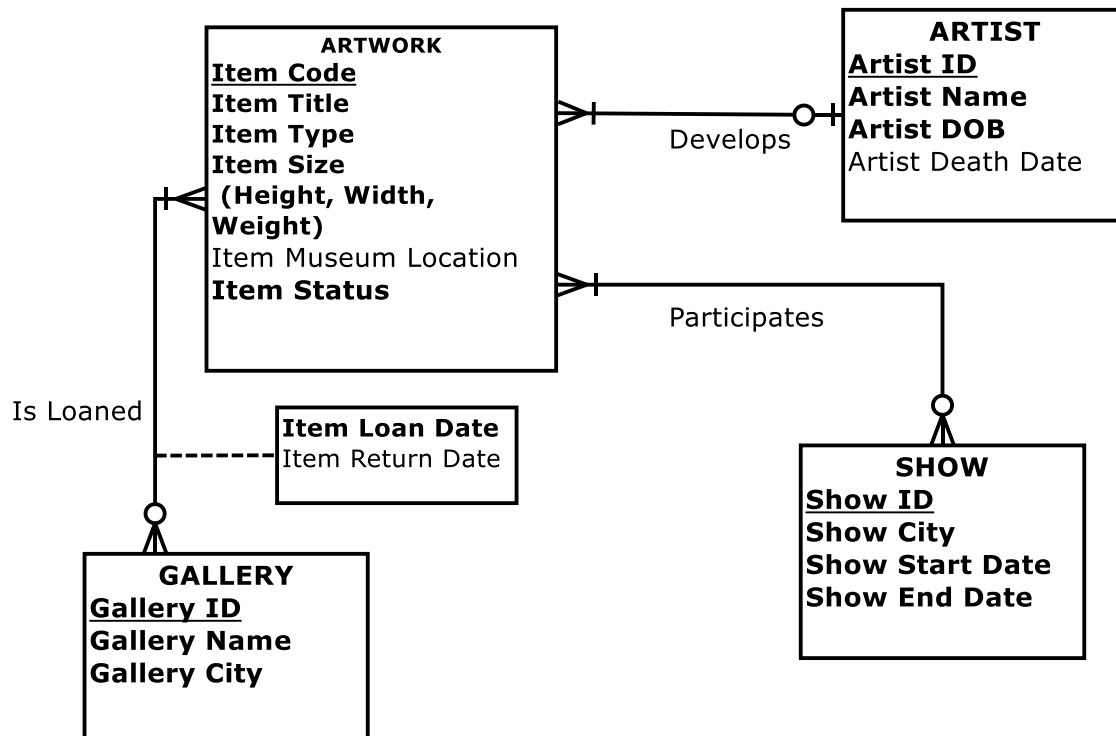

17.g. Art Museum ERD

Diagram Notes for Problem & Exercise 17.g:

- ARTWORK is created by 0:1 ARTIST (0 for Unknown ARTIST); alternative design would be to have a valid ARTIST instance with a Name of “Unknown”; this would enable you to enforce a business rule that each piece of ARTWORK must have an ARTIST stored in the database and the cardinality would change to mandatory one near the ARTIST entity in the diagram.
- Item Status attribute of ARTWORK permits designation of ARTWORK as Display (and then a valid value for Item Museum Location attribute), Storage, Loan, or Show.
- An ARTWORK item may participate in a SHOW; however, there is not a way to note on the ERD that an ARTWORK item cannot be a part of two shows with overlapping dates. This business constraint will need to be noted as part of the system design documentation.

17.h. Law Firm ERD

Note: This problem and exercise is a good lead-in for Chapter 3 modeling notation for the Enhanced Entity Relationship Diagram (EERD). The P&E offers several chances to provide better representation in the EERD (with subtyping) than the ERD notation that is provided in Chapter 2. Using EERD notation, a single LEGAL ENTITY can be shown as a supertype, with subtypes of DEFENDANT and PLAINTIFF. The “type” (person or organization) characteristic of both DEFENDANT and PLAINTIFF may also be considered for further subtyping. The solution presented here is a valid answer to the P&E, given the limitations of basic ERD notation and what is currently known about the situation.

This P&E also provides the instructor with an opportunity to discuss how history might be modeled if the business assumption regarding the tracking of Net Worth for both Plaintiff and Defendant was changed from only being concerned with Net Worth at the time of the CASE, to wanting to track the Net Worth over time of each party to the CASE. Refer to the chapter section on “Modeling Time-Dependent Data” and Figure 2-19 for more information on how this ERD could be revised.

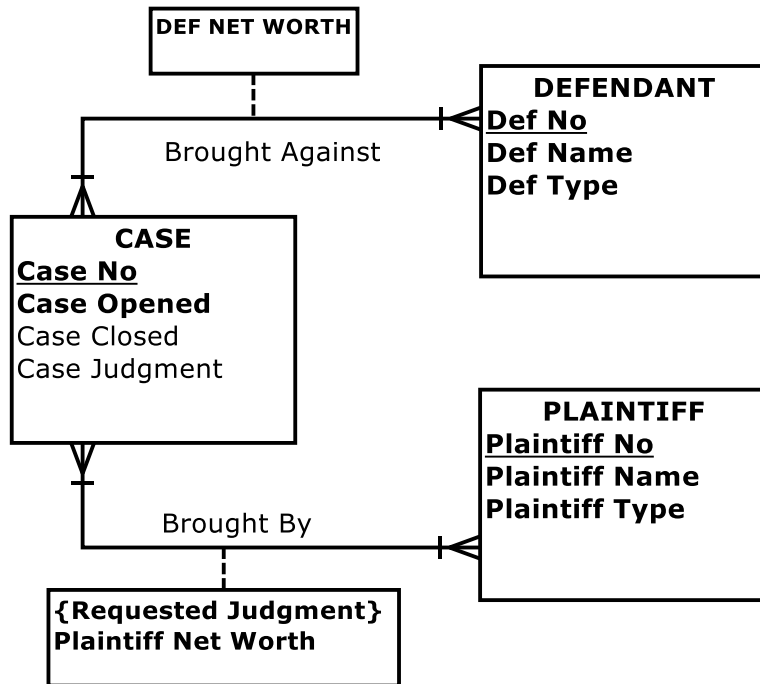

Diagram Notes for Problem & Exercise 17.h:

- Def Type and Plaintiff Type are used to denote Person or Organization type of legal entity.
- Net Worth of both Plaintiff and Defendant is relevant only at the time of the CASE, thus are modeled as attributes of the M:N relationships between CASE and PLAINTIFF, DEFENDANT.

17.i. Publisher, author, book ERD

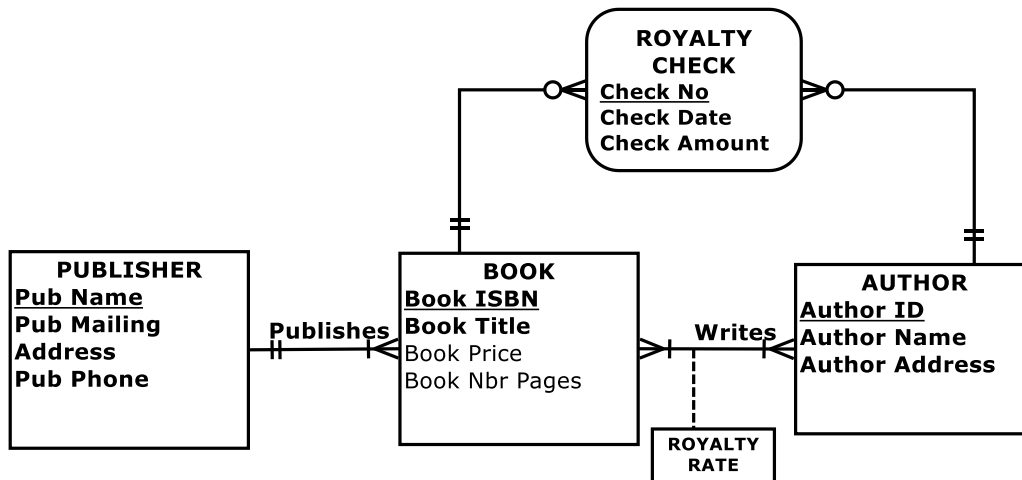

Diagram Note for Problem & Exercise 17.i: No checks are written before the first royalty is paid, thus the minimum cardinality is 0 for the Royalty Check Associative Entity.

18. PVFC ERD alternative representation

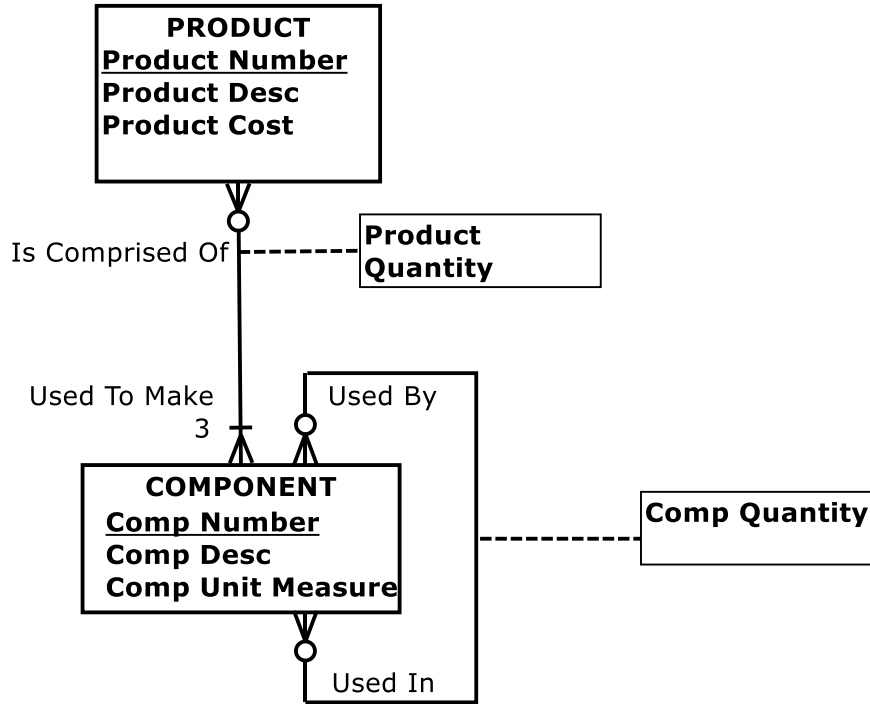

Diagram Note for Problem & Exercise 18: A COMPONENT may be Used To Make 0:M PRODUCTS, as a COMPONENT may be a raw material that is not used immediately in making a PRODUCT.

19. Emerging Electric ERD

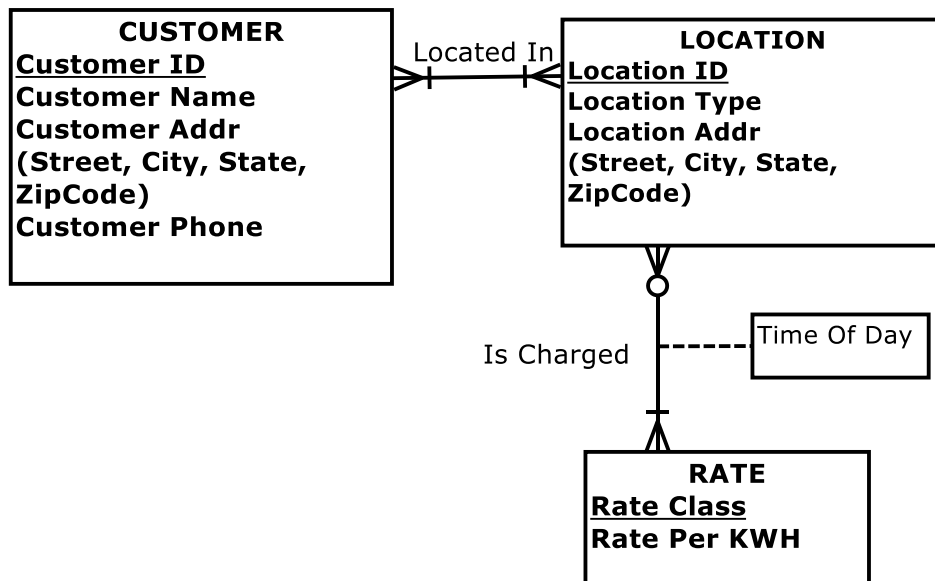
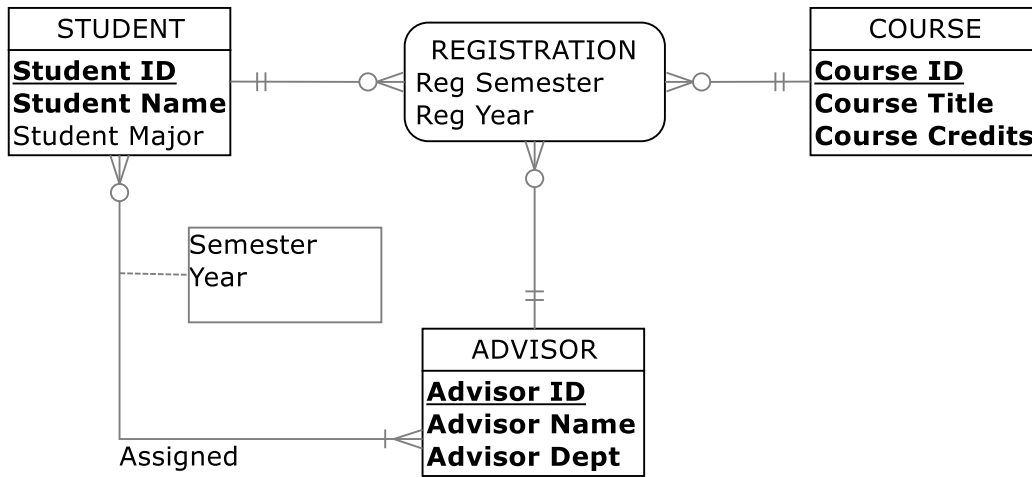

Diagram Notes for Problem & Exercise 19:

- A RATE may be for one, none, or many LOCATIONS.
- A LOCATION may have multiple CUSTOMERS.
- A CUSTOMER may own multiple LOCATIONS.

20. *STUDENT and ADVISORs ERD*



21. *Figure 2-4a Revised for Sarbanes-Oxley compliance purposes*

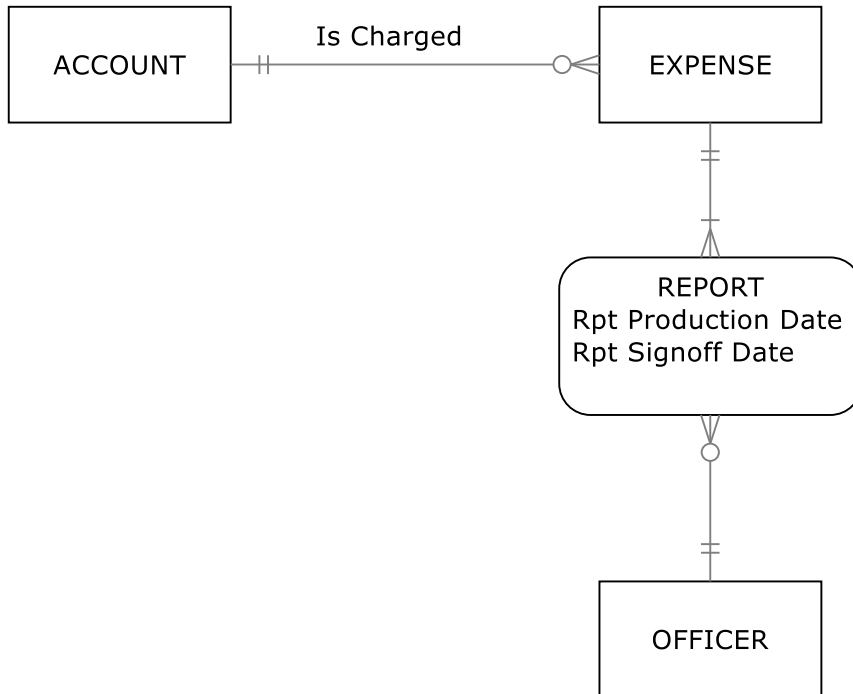

22. Real Estate Firm ERD

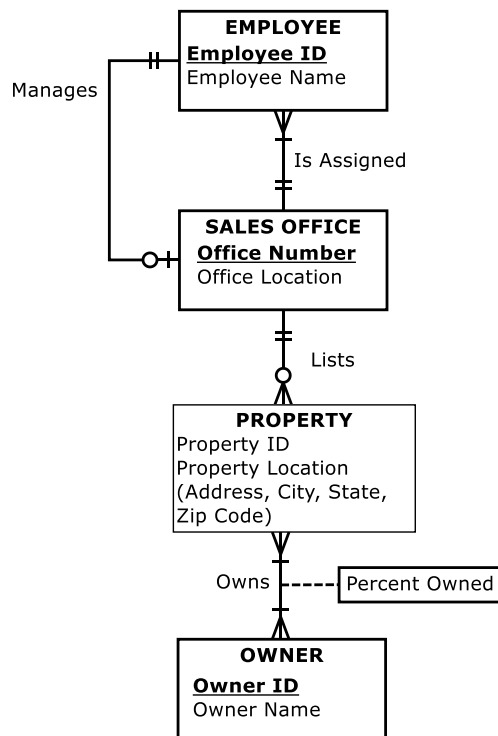

Diagram Note for Problem & Exercise 22: An additional business rule for this scenario is that an EMPLOYEE may Manage only the SALES OFFICE to which s/he Is Assigned.

Entities:

Employee: An employee of the firm. An employee works for one sales office and may manage one sales office. It is not explicitly indicated that the employee can only manage the office that he/she works for. This would be specified as a business rule.

Sales Office: The office where real estate is sold.

Property: Buildings for sale, such as houses, condos and apartment buildings.

Owner: The individual who owns one or more properties.

Attributes on Employee:

Employee ID: A unique identifier for an employee. This attribute must be unique.

Employee Name: The name of the employee.

Attributes on Sales Office:

Office Number: A unique identifier for the office.

Office Location: The physical location of the sales office. This data may be made up of the city and state.

Attributes on Property:

Property ID: The unique identifier for the property.

Property Location: A composite attribute that consists of the street address, city, state, and Zip Code.

Attributes on Owner:

Owner ID: The unique identifier for the owner.

Owner Name: The name of the owner.

Relationship:

Is Assigned: An employee is assigned to one sales office. A sales office may have many employees assigned but must have at least one employee.

Manages: An employee may manage one sales office or no sales office. Each sales office is managed by one employee. A business rule is needed here in order to indicate that an employee can only manage the sales office in which he or she works.

Lists: Each property is listed by only one sales office. Each sales office can list one, none, or many properties.

Owns: Each property has one or more owners. Each owner can own one or more properties. Percent Owned is an attribute on Owns; it tracks the percent of property that a particular owner owns.

23. Preliminary ERD for Symphony Orchestra

Business Rule: A concert includes the performance of one or more compositions; a composition may be performed at one or more concerts or may not be performed. This business rule is modeled in the ERD above through the use of the COMPOSITION and CONCERT entities, together with the PERFORMANCE Associative Entity.

Note: The use of the Associative Entity PERFORMANCE also permits the independent binary relationship between SOLOIST and PERFORMANCE, which permits the model to support the tracking of derived data, Date Last Performed. Although the diagram *appears* to represent a ternary relationship among COMPOSITION, CONCERT, SOLOIST and PERFORMANCE, such a ternary relationship would not accurately reflect the requirements of the problem. Rather, the needs of the problem state that there is an overall M:N binary relationship between SOLOIST and PERFORMANCE, which permits the tracking of multiple soloists performing any given composition as well as a given soloist performing multiple compositions.

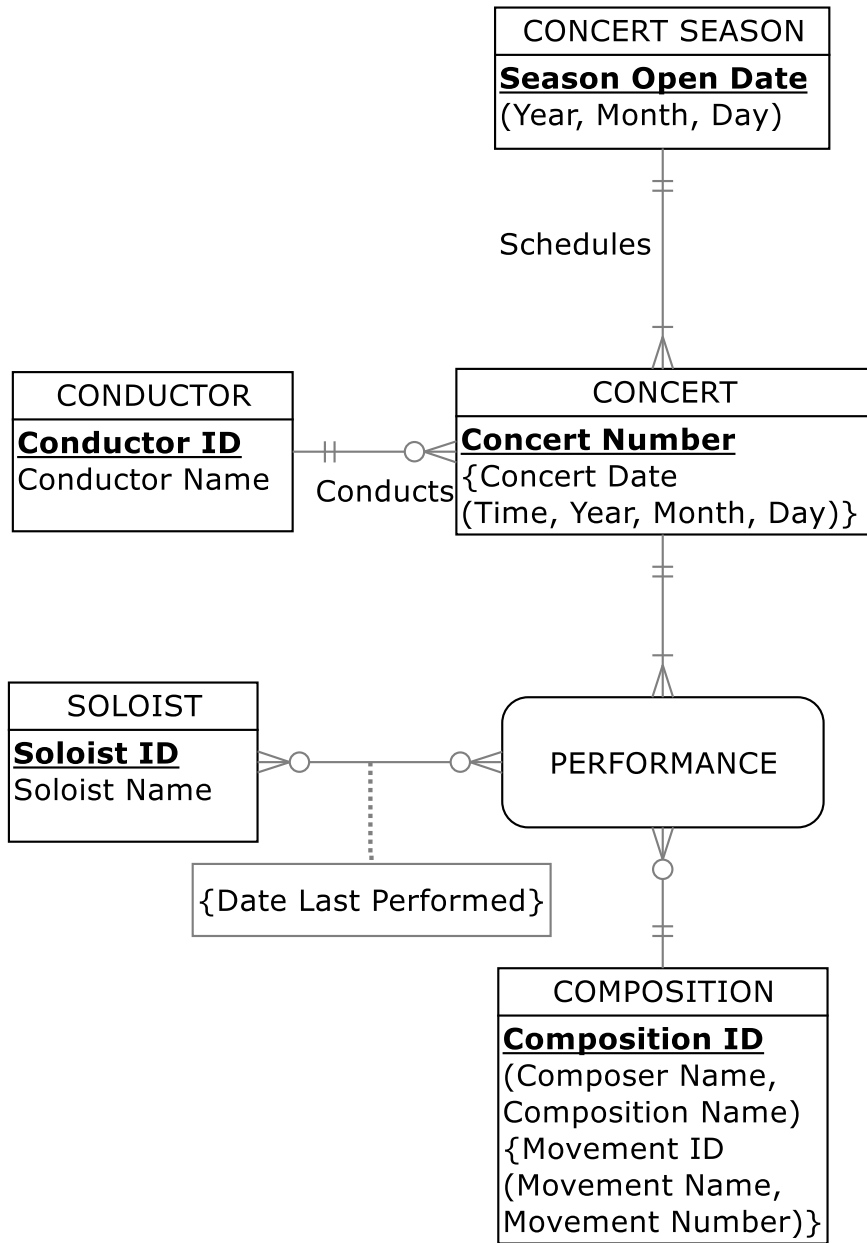

24. Stillwater Antiques ERD

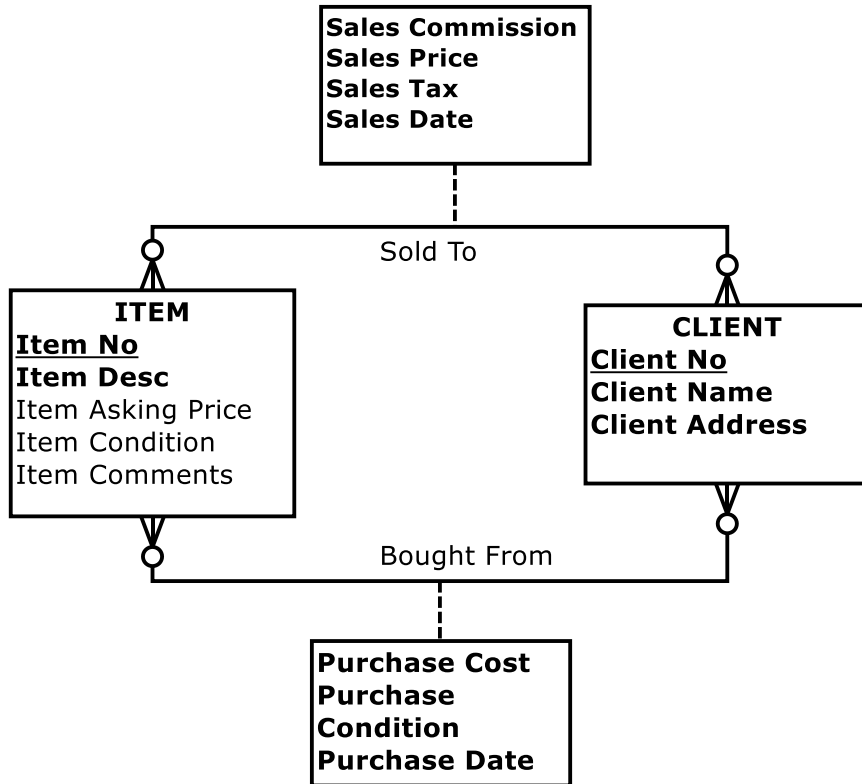

25. A.M. Honka School of Business ERD

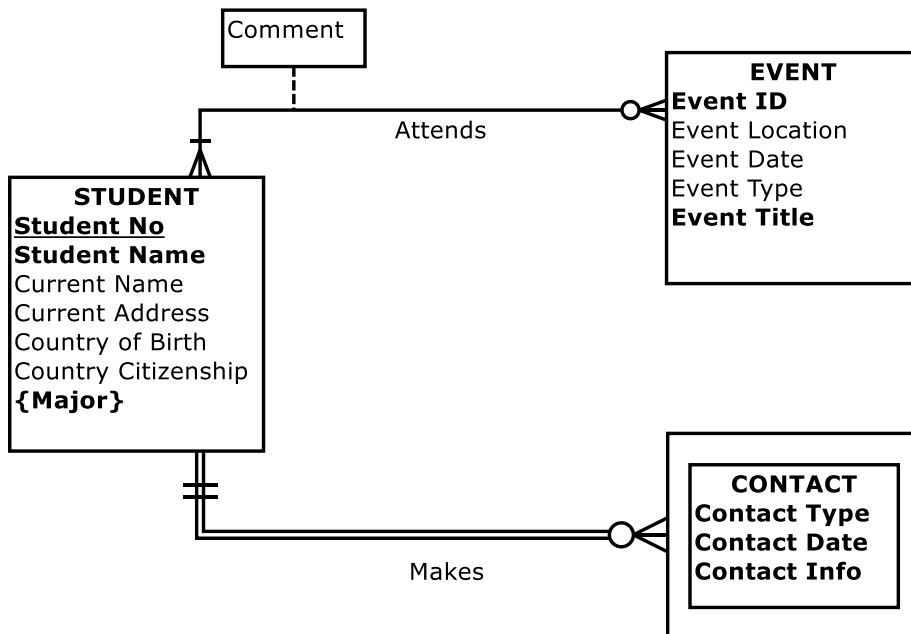

Note: Contact Type refers to mail, email, telephone, fax, or personal discussion.

26. Wally's Wonderful World of Wallcoverings ERD:

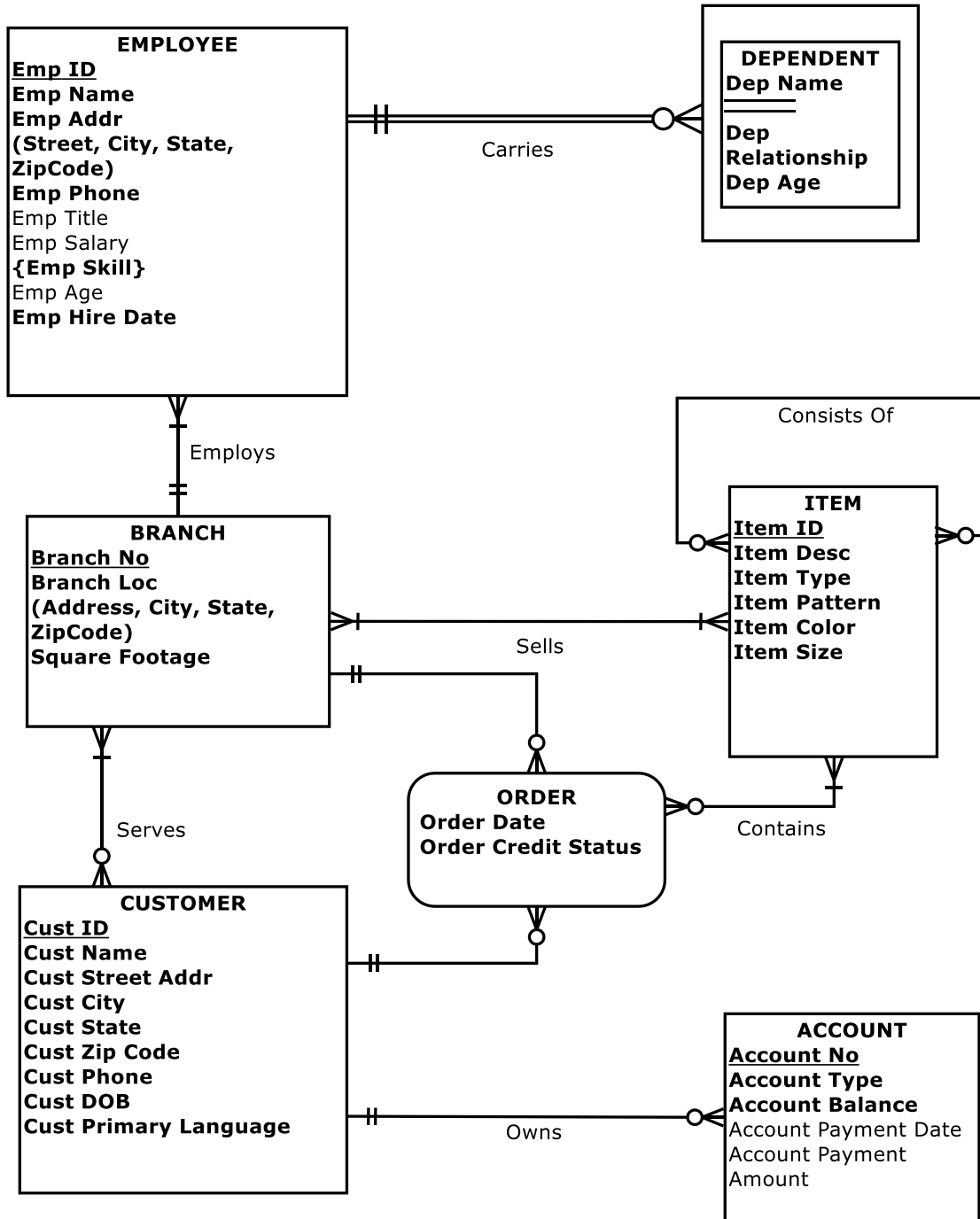

Note:

The question does not indicate that there is a quantity for the Contains or Consists Of relationships.

27. Peck and Paw ERD:

