

**CHAPTER 2, FORM A
COLLEGE ALGEBRA AND TRIGONOMETRY**

NAME _____
DATE _____

1. Match the set described in Column I with the correct interval notation from Column II. Choices in Column II may be used once, more than once, or not at all.

- | I | II |
|--------------------------------------|------------------------|
| a. Domain of $f(x) = \sqrt{x-3}$ | A. $(-\infty, \infty)$ |
| b. Range of $f(x) = \sqrt{x} - 3$ | B. $[3, \infty)$ |
| c. Domain of $f(x) = x^2 - 16$ | C. $[0, 2]$ |
| d. Range of $y = 2x^2$ | D. $[0, \infty)$ |
| e. Domain of $f(x) = \sqrt[3]{x-2}$ | E. $[-3, 3]$ |
| f. Range of $f(x) = \sqrt[3]{x} + 2$ | F. $(-\infty, -2]$ |
| g. Domain of $f(x) = x+2 $ | G. $[-3, \infty)$ |
| h. Range of $f(x) = x +3$ | H. $[-7, \infty)$ |
| i. Domain of $y = 2s^2$ | |
| j. Range of $f(x) = x^2 - 7$ | |

1. a. _____
 b. _____
 c. _____
 d. _____
 e. _____
 f. _____
 g. _____
 h. _____
 i. _____
 j. _____

The graph shows the line that passes through the points $(-5, -3)$ and $(-1, 4)$. Refer to it to answer Exercises 2–6.

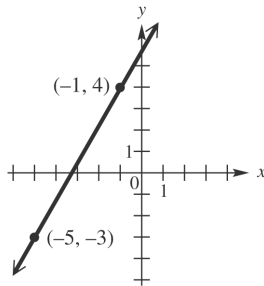

- | | |
|---|----------|
| 2. What is the slope of the line? | 2. _____ |
| 3. What is the distance between the two points shown? | 3. _____ |
| 4. What are the coordinates of the midpoint of the <i>segment</i> joining the two points? | 4. _____ |
| 5. Find the standard form of the equation of the line. | 5. _____ |
| 6. Write the linear function defined by $f(x) = ax + b$ that has this line as its graph. | 6. _____ |

CHAPTER 2, FORM A

Tell whether each graph is that of a function. Give the domain and the range. If it is a function, give the intervals where it is increasing, decreasing, or constant.

7.

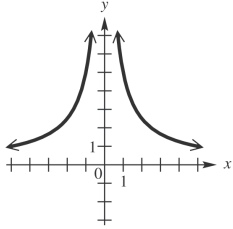

7. _____

8.

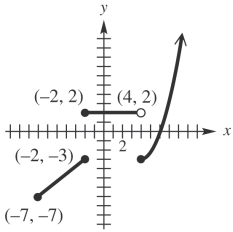

8. _____

9. Suppose point P has coordinates $\left(\frac{2}{5}, \frac{3}{7}\right)$.

- a. What is the equation of the vertical line through P ?
- b. What is the equation of the horizontal line through P ?

9. a. _____
 b. _____

10. Find the slope-intercept form of the equation of the line passing through $(2, 5)$ and

- a. parallel to the graph of $y = 4x - 7$;
- b. perpendicular to the graph of $y = 4x - 7$.

10. a. _____
 b. _____

Graph each relation.

11. $x = 2|y - 3| + 1$

11.

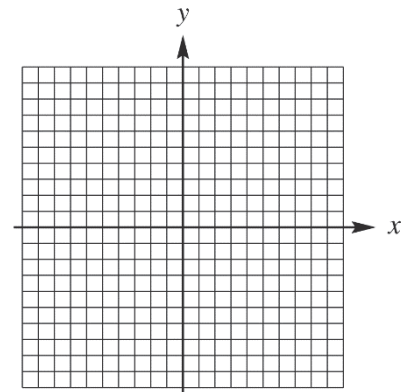

CHAPTER 2, FORM A

12. $f(x) = \lceil x \rceil + 2$

12.

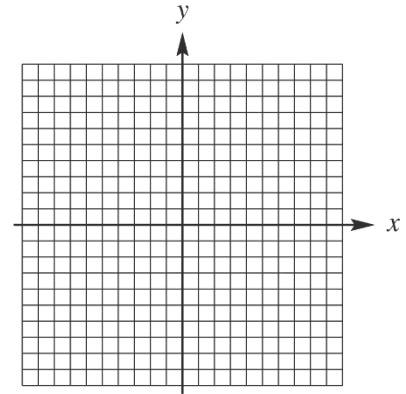

13. $f(x) = \begin{cases} 2x-1 & \text{if } x < 0 \\ -3x-1 & \text{if } x \geq 0 \end{cases}$

13.

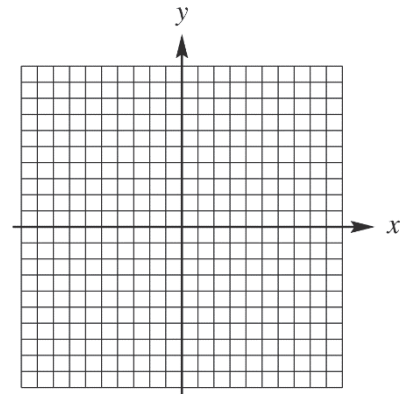

14. Explain how the graph of $y = -\frac{1}{2}\sqrt{x+3} + 5$ can be obtained from the graph of $y = \sqrt{x}$.

14. _____

15. Determine whether the graph of $2x^2 + 3y^2 = 1$ is symmetric with respect to

15. a. _____

a. the x-axis,

b. _____

b. the y-axis,

c. _____

c. the origin.

Given $f(x) = x^2 - 1$ and $g(x) = 2x + 1$, find each of the following. Simplify the expressions when possible.

16. $(fg)(x)$

16. _____

17. $(f + g)(x)$

17. _____

18. the domain of $\frac{g}{f}$

18. _____

CHAPTER 2, FORM A

19. $\frac{f(x+h) - f(x)}{h}$

19. _____

20. $(f - g)(0)$

20. _____

21. $\left(\frac{f}{g}\right)(2)$

21. _____

22. $(f \circ g)(x)$

22. _____

23. $(f \circ g)(-2)$

23. _____

24. $(g \circ f)(x)$

24. _____

25. $(g \circ f)(-2)$

25. _____

CHAPTER 2, FORM B
COLLEGE ALGEBRA AND TRIGONOMETRY

NAME _____
 DATE _____

1. Match the set described in Column I with the correct interval notation from Column II. Choices in Column II may be used once, more than once, or not at all.

- | I | II |
|--------------------------------------|------------------------|
| a. Domain of $f(x) = \sqrt{x-4}$ | A. $(-\infty, \infty)$ |
| b. Range of $f(x) = \sqrt{x} - 2$ | B. $[-2, \infty)$ |
| c. Domain of $f(x) = 3x^2$ | C. $[0, 2]$ |
| d. Range of $f(x) = x^2 + 5$ | D. $[0, \infty)$ |
| e. Domain of $f(x) = \sqrt[3]{x-8}$ | E. $[-3, 3]$ |
| f. Range of $f(x) = \sqrt[3]{x} - 1$ | F. $(-\infty, -2]$ |
| g. Domain of $f(x) = x-2 $ | G. $[5, \infty)$ |
| h. Range of $f(x) = x + 5$ | H. $[4, \infty)$ |
| i. Domain of $x = 2y^2$ | |
| j. Range of $x = 2y^2$ | |

1. a. _____
 b. _____
 c. _____
 d. _____
 e. _____
 f. _____
 g. _____
 h. _____
 i. _____
 j. _____

The graph shows the line that passes through the points $(-2, -1)$ and $(4, -3)$. Refer to it to answer Exercises 2–6.

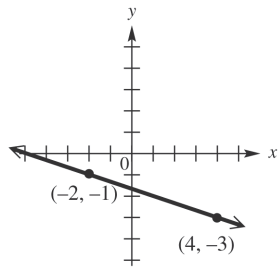

- | | |
|---|----------|
| 2. What is the slope of the line? | 2. _____ |
| 3. What is the distance between the two points shown? | 3. _____ |
| 4. What are the coordinates of the midpoint of the <i>segment</i> joining the two points? | 4. _____ |
| 5. Find the standard form of the equation of the line. | 5. _____ |
| 6. Write the linear function defined by $f(x) = ax + b$ that has this line as its graph. | 6. _____ |

CHAPTER 2, FORM B

Tell whether each graph is that of a function. Give the domain and the range. If it is a function, give the intervals where it is increasing, decreasing, or constant.

7.

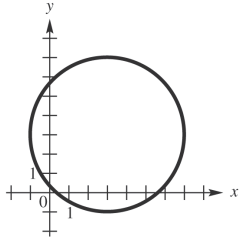

7. _____

8.

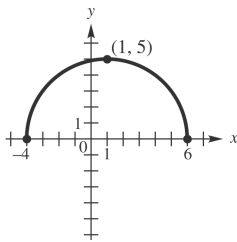

8. _____

Graph each relation.

9. $f(x) = 2 - |3x|$

9.

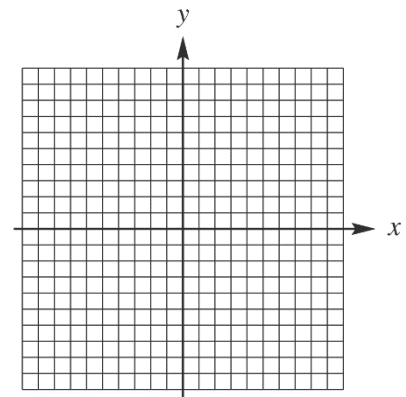

10. $f(x) = \left\lfloor \frac{1}{2}x \right\rfloor$

10.

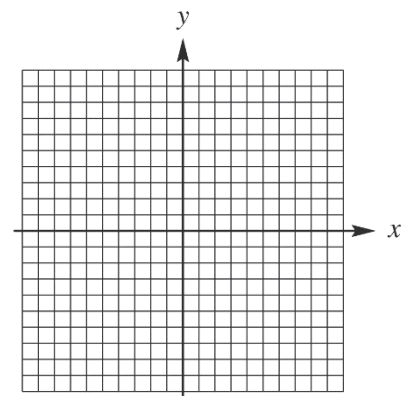

CHAPTER 2, FORM B

11.
$$f(x) = \begin{cases} -2x & \text{if } x < -3 \\ 4 & \text{if } -3 \leq x \leq 2 \\ x-4 & \text{if } x \geq 2 \end{cases}$$

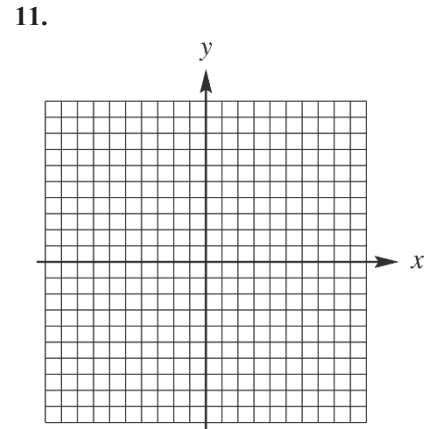

12. Suppose point P has coordinates $\left(\frac{5}{8}, -\frac{7}{9}\right)$.

- a. What is the equation of the vertical line through P ?
- b. What is the equation of the horizontal line through P ?

- 12. a. _____
- b. _____

13. Find the slope-intercept form of the equation of the line passing through $(-6, 3)$ and

- a. parallel to the graph of $y = -3x - 12$;
- b. perpendicular to the graph of $y = -3x - 12$.

- 13. a. _____
- b. _____

14. Explain how the graph of $y = -\frac{1}{3}\sqrt{x+4} + 2$ can be obtained from the graph of $y = \sqrt{x}$.

14. _____

15. Determine whether the graph of $y^2 = 3x$ is symmetric with respect to

- a. the x -axis,
- b. the y -axis,
- c. the origin.

- 15. a. _____
- b. _____
- c. _____

Given $f(x) = 2x^2 + 7x + 6$ and $g(x) = 3x - 2$, find each of the following. Simplify the expressions when possible.

16. $(fg)(x)$

16. _____

17. $(f - g)(x)$

17. _____

18. the domain of $\frac{g}{f}$

18. _____

CHAPTER 2, FORM B

19. $\frac{f(x+h) - f(x)}{h}$

19. _____

20. $(f + g)(1)$

20. _____

21. $\left(\frac{g}{f}\right)(0)$

21. _____

22. $(f \circ g)(x)$

22. _____

23. $(f \circ g)(1)$

23. _____

24. $(g \circ f)(x)$

24. _____

25. $(g \circ f)(1)$

25. _____

CHAPTER 2, FORM C
COLLEGE ALGEBRA AND TRIGONOMETRY

NAME _____
 DATE _____

1. Match the set described in Column I with the correct interval notation from Column II. Choices in Column II may be used once, more than once, or not at all.

- | I | II |
|--------------------------------------|------------------------|
| a. Domain of $f(x) = \sqrt{x+2}$ | A. $(-\infty, \infty)$ |
| b. Range of $f(x) = \sqrt{x} - 4$ | B. $[-4, \infty)$ |
| c. Domain of $f(x) = x^2 - 1$ | C. $[0, 2]$ |
| d. Range of $f(x) = x^2 - 16$ | D. $[0, \infty)$ |
| e. Domain of $f(x) = \sqrt[3]{x-2}$ | E. $[-3, 3]$ |
| f. Range of $f(x) = \sqrt[3]{x} + 2$ | F. $(-\infty, -3]$ |
| g. Domain of $f(x) = x+3 $ | G. $[-1, \infty)$ |
| h. Range of $f(x) = x -3$ | H. $[-2, \infty)$ |
| i. Domain of $y = 2x^2$ | |
| j. Range of $y = x^2 - 3$ | |

1. a. _____
 b. _____
 c. _____
 d. _____
 e. _____
 f. _____
 g. _____
 h. _____
 i. _____
 j. _____

The graph shows the line that passes through the points $(-3, -5)$ and $(3, -2)$. Refer to it to answer Exercises 2–6.

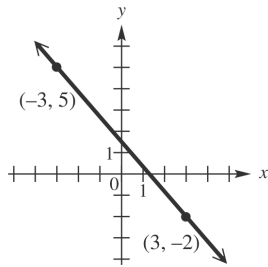

- | | |
|---|----------|
| 2. What is the slope of the line? | 2. _____ |
| 3. What is the distance between the two points shown? | 3. _____ |
| 4. What are the coordinates of the midpoint of the <i>segment</i> joining the two points? | 4. _____ |
| 5. Find the standard form of the equation of the line. | 5. _____ |
| 6. Write the linear function defined by $f(x) = ax + b$ that has this line as its graph. | 6. _____ |

CHAPTER 2, FORM C

Tell whether each graph is that of a function. Give the domain and the range. If it is a function, give the intervals where it is increasing, decreasing, or constant.

7.

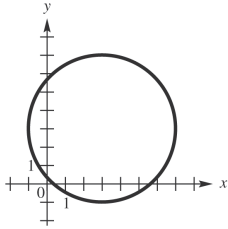

7. _____

8.

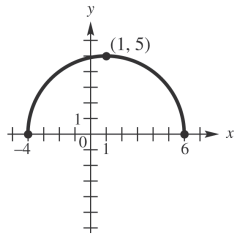

8. _____

9. Suppose point P has coordinates $(2\sqrt{2}, -\sqrt{5})$.

a. What is the equation of the vertical line through P ?

9. a. _____

b. What is the equation of the horizontal line through P ?

b. _____

10. Find the slope-intercept form of the equation of the line passing through $(4, -2)$ and

a. parallel to the graph of $x = \frac{5}{4}y - 2$;

10. a. _____

b. perpendicular to the graph of $x = \frac{5}{4}y - 2$;

b. _____

CHAPTER 2, FORM C

Graph each relation.

11. $f(x) = \frac{1}{2}|x+1| - 2$

11.

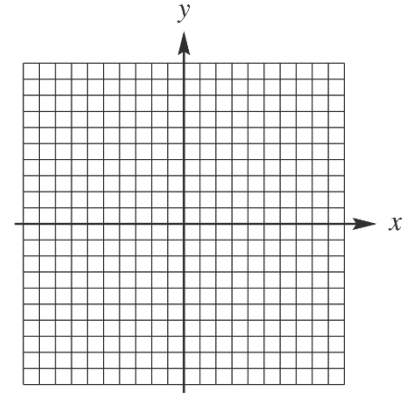

12. $f(x) = \llbracket 2x \rrbracket - 2$

12.

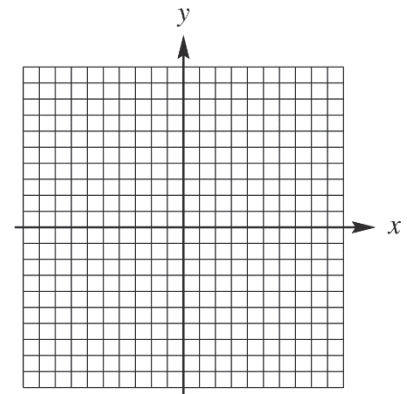

13. $f(x) = \begin{cases} x+1 & \text{if } x \leq -2 \\ -1 & \text{if } x > -2 \end{cases}$

13.

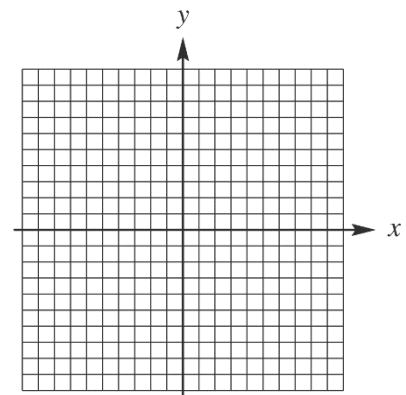

CHAPTER 2, FORM C

14. Explain how the graph of $y = 3|x + 4| + 2$ can be obtained from the graph of $y = |x|$. 14. _____

15. Determine whether the graph of $y = 3x^2 + 7$ is symmetric with respect to 15. a. _____

a. the x -axis, b. _____

b. the y -axis, c. _____

c. the origin.

Given $f(x) = 3x^2 - 2$ and $g(x) = 4x + 4$, find each of the following. Simplify the expressions when possible.

16. $(fg)(x)$ 16. _____

17. $(g - f)(x)$ 17. _____

18. $f(-2)$ 18. _____

19. $\frac{f(x+h) - f(x)}{h}$ 19. _____

20. $(f + g)(0)$ 20. _____

21. $\left(\frac{f}{g}\right)(-2)$ 21. _____

22. $(f - g)(x)$ 22. _____

23. $(f \circ g)(x)$ 23. _____

24. $(g \circ f)(x)$ 24. _____

25. $(g \circ f)(0)$ 25. _____

CHAPTER 2, FORM D
COLLEGE ALGEBRA AND TRIGONOMETRY

NAME _____
 DATE _____

1. Match the set described in Column I with the correct interval notation from Column II. Choices in Column II may be used once, more than once, or not at all.

- | I | II |
|--------------------------------------|------------------------|
| a. Domain of $f(x) = \sqrt{x+1}$ | A. $(-\infty, -1]$ |
| b. Range of $f(x) = \sqrt{x} + 1$ | B. $(-\infty, \infty)$ |
| c. Domain of $f(x) = x^2 - 25$ | C. $[0, 2]$ |
| d. Range of $f(x) = x^2 - 1$ | D. $[0, \infty)$ |
| e. Domain of $f(x) = \sqrt[3]{x-2}$ | E. $[-3, 3]$ |
| f. Range of $f(x) = \sqrt[3]{x} + 2$ | F. $[-3, \infty)$ |
| g. Domain of $f(x) = x+4 $ | G. $[-1, \infty)$ |
| h. Range of $f(x) = x - 4$ | H. $[-4, \infty)$ |
| i. Domain of $y = 2x^2$ | |
| j. Range of $y = x^2 - 4$ | |

1. a. _____
 b. _____
 c. _____
 d. _____
 e. _____
 f. _____
 g. _____
 h. _____
 i. _____
 j. _____

The graph shows the line that passes through the points $(-7, -4)$ and $(3, -2)$. Refer to it to answer Exercises 2–6.

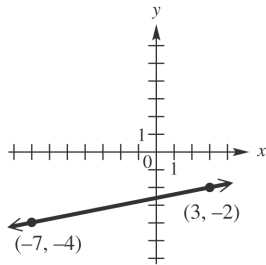

- | | |
|---|----------|
| 2. What is the slope of the line? | 2. _____ |
| 3. What is the distance between the two points shown? | 3. _____ |
| 4. What are the coordinates of the midpoint of the <i>segment</i> joining the two points? | 4. _____ |
| 5. Find the standard form of the equation of the line. | 5. _____ |
| 6. Write the linear function defined by $f(x) = ax + b$ that has this line as its graph. | 6. _____ |

CHAPTER 2, FORM D

Tell whether each graph is that of a function. Give the domain and the range. If it is a function, give the intervals where it is increasing, decreasing, or constant.

7.

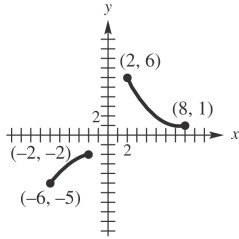

7. _____

8.

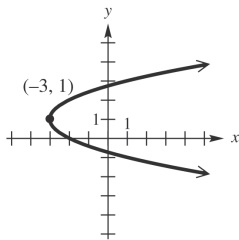

8. _____

Graph each relation.

9. $f(x) = 3 + |x + 1|$

9.

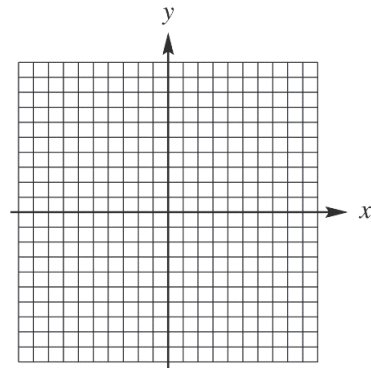

10. $f(x) = \begin{cases} -x & \text{if } x < 0 \\ 2x & \text{if } x \geq 0 \end{cases}$

10.

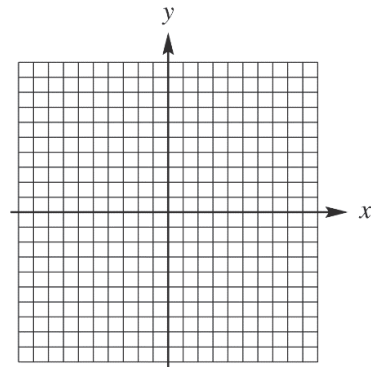

CHAPTER 2, FORM D

11. Suppose point P has coordinates $(-3, 2.1)$.
- a. What is the equation of the vertical line through P ? 11. a. _____
- b. What is the equation of the horizontal line through P ? b. _____
12. Find the slope-intercept form of the equation of the line passing through $(1, -5)$ and
- a. parallel to the graph of $x = -\frac{3}{4}y + 5$; 12. a. _____
- b. perpendicular to the graph of $x = -\frac{3}{4}y + 5$; b. _____
13. Find the slope of the line through points $(11, -5)$ and $(-8, 6)$. 13. _____
 from the graph of $y = \sqrt{x}$.
14. Explain how the graph of $y = 3\sqrt{x-4} - 2$ can be obtained 14. _____
 from the graph of $y = \sqrt{x}$.
15. Determine whether the graph of $xy = -4$ is symmetric 15. a. _____
 with respect to b. _____
- a. the x -axis, c. _____
- b. the y -axis,
- c. the origin.

Given $f(x) = 2x^3 - 3x - 1$ and $g(x) = 2x + 1$, find each of the following. Simplify the expressions when possible.

16. $(f + g)(x)$ 16. _____
17. $\left(\frac{f}{g}\right)(x)$ 17. _____
18. $f(0)$ 18. _____
19. $\frac{f(x+h) - f(x)}{h}$ 19. _____
20. $(g - f)(0)$ 20. _____
21. $(fg)(-1)$ 21. _____
22. $(f \circ g)(x)$ 22. _____

CHAPTER 2, FORM D

23. $(f \circ g)(2)$

24. $(g \circ f)(x)$

25. $(g \circ f)(2)$

23. _____

24. _____

25. _____

**CHAPTER 2, FORM E
COLLEGE ALGEBRA AND TRIGONOMETRY**

NAME _____
DATE _____

Choose the best answer.

- 1a. Which of the following is the domain of $f(x) = \sqrt{3-x}$? 1a. _____
 a. $[0, 3]$ b. $(-\infty, 3]$
 c. $[3, \infty)$ d. $(-\infty, \infty)$
- 1b. Which of the following is the range of $f(x) = x^2 - 49$? 1b. _____
 a. $[-49, \infty)$ b. $[-7, \infty)$
 c. $[-7, 7]$ d. $[0, \infty)$
- 1c. Which of the following is the domain of $f(x) = \sqrt[3]{x+7}$? 1c. _____
 a. $(-\infty, \infty)$ b. $(-\infty, 6]$
 c. $[0, \infty)$ d. $[6, \infty)$
- 1d. Which of the following is the range of $f(x) = |x| + 1$? 1d. _____
 a. $[-1, 1]$ b. $[0, 1]$
 c. $[0, \infty)$ d. $[1, \infty)$
- 1e. Which of the following is the domain of $x = y^2$? 1e. _____
 a. $(-\infty, \infty)$ b. $[0, \infty)$
 c. $(0, \infty)$ d. $(-\infty, 0]$

The graph shows the line that passes through $(-5, 8)$ and $(4, -3)$. Refer to it to answer Exercises 2-6.

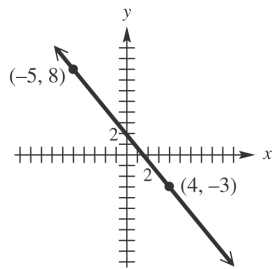

2. What is the slope of the line? 2. _____
 a. $-\frac{13}{7}$ b. $\frac{11}{9}$
 c. $-\frac{11}{9}$ d. 0
3. What is the distance between the two points shown? 3. _____
 a. $\sqrt{26}$ b. $2\sqrt{5}$
 c. $\sqrt{202}$ d. $\sqrt{122}$

CHAPTER 2, FORM E

4. What are the coordinates of the midpoint of the segment joining the two points?

- a. $\left(-\frac{1}{2}, \frac{5}{2}\right)$ b. $\left(-\frac{9}{2}, \frac{11}{2}\right)$
 c. $\left(\frac{3}{2}, \frac{1}{2}\right)$ d. $(-1, 5)$

4. _____

5. Find the standard form of the equation of the line.

- a. $11x + 9y = 127$ b. $11x - 9y = 17$
 c. $11x + 9y = 17$ d. $11x - 9y = 127$

5. _____

6. Find the standard form of the equation of the line.

- a. $f(x) = \frac{11}{9}x - \frac{17}{9}$ b. $f(x) = -\frac{11}{9}x + \frac{17}{9}$
 c. $f(x) = \frac{11}{9}x + \frac{127}{9}$ d. $f(x) = \frac{11}{9}x - \frac{127}{9}$

6. _____

Tell whether each graph is that of a function. Give the domain and range.

7.

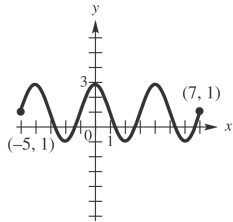

7. _____

- a. Function; domain: $[-5, 7]$; range: $[-1, 3]$
 b. Function; domain: $(-\infty, \infty)$; range: $[-1, 3]$
 c. Function; domain: $[-1, 3]$; range: $[-5, 7]$
 d. Not a function; domain: $[-5, 7]$; range: $[-1, 3]$

8.

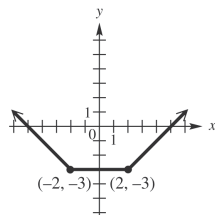

8. _____

- a. Not a function; domain: $(-\infty, \infty)$; range: $[-2, \infty)$
 b. Not a function; domain: $[-5, 5]$; range: $[-3, \infty)$
 c. Function; domain: $(-\infty, \infty)$; range: $[-2, \infty)$
 d. Function; domain: $(-\infty, \infty)$; range: $[-3, \infty)$

CHAPTER 2, FORM E

9. Suppose point P has coordinates $(-6, 1)$.

What is the equation of the horizontal line through P ?

- a. $x = -6$ b. $y = 1$
 c. $x = 1$ d. $y = 6$

9. _____

10. Find the slope-intercept form of the equation of the line passing.

through $(-2, 5)$ perpendicular to the graph of $y = -\frac{1}{8}x + \frac{19}{4}$.

- a. $y = 8x + 21$ b. $y = \frac{1}{3}x - 3$
 c. $y = -8x - 13$ d. $y = -\frac{1}{3}x + 3$

10. _____

Graph each function.

11. $f(x) = 2|x - 1| - 2$

11. _____

a.

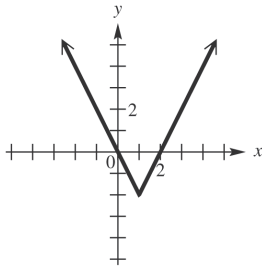

b.

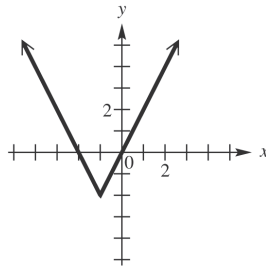

c.

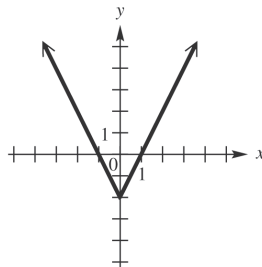

d.

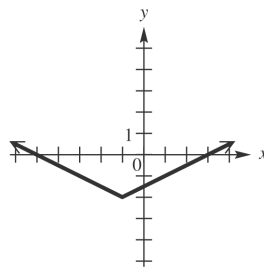

CHAPTER 2, FORM E

12. $f(x) = \left\lfloor \frac{1}{2}x \right\rfloor$

12. _____

a.

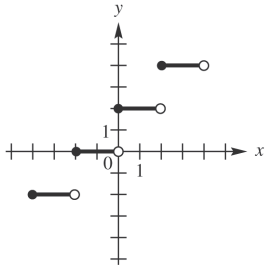

b.

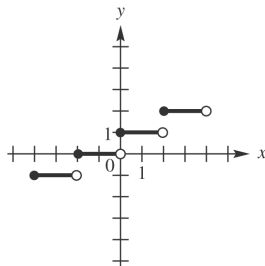

c.

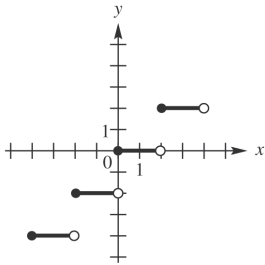

d.

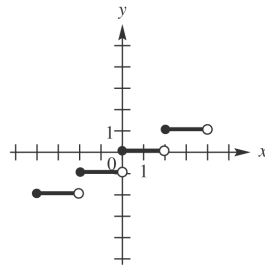

13. $f(x) = \begin{cases} 2 & \text{if } x < -2 \\ -\frac{1}{2}x + 1 & \text{if } x \geq -2 \end{cases}$

13. _____

a.

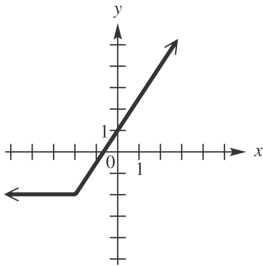

b.

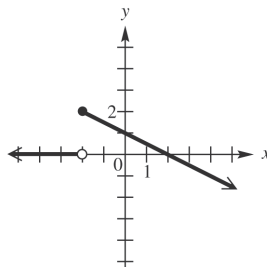

c.

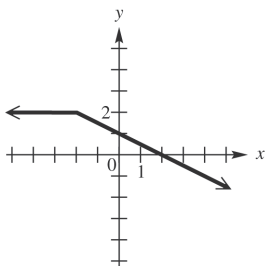

d.

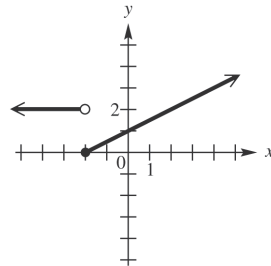

CHAPTER 2, FORM E

14. Explain how the graph of $y = \sqrt{x+2} - 5$ can be obtained from the graph of $y = \sqrt{x}$. 14. _____
- Translate 2 unit to the right and 5 units up.
 - Translate 2 unit to the right and 5 units down.
 - Translate 2 unit to the left and 5 units up.
 - Translate 2 unit to the left and 5 units down.

15. Determine the symmetries of the graph of the relation $x^2 - 2xy + y^2 = 5$. 15. _____
- x -axis only
 - y -axis only
 - origin only
 - x -axis, y -axis, and origin

Given $f(x) = 5x - 4$ and $g(x) = x^2 + 3$, find each of the following. Simplify the expressions when possible.

16. $(fg)(x)$ 16. _____
- $x^3 + 4x^2 - 12$
 - $5x^3 - 4x^2 + 15x - 12$
 - $5x^3 + 4x^2 + 3x - 12$
 - $-5x^3 + 4x^2 - 5x - 12$

17. $(g - f)(x)$ 17. _____
- $x^2 - 5x + 7$
 - $x^2 + 5x - 7$
 - $-x^2 - 5x + 1$
 - $x^2 + 5x + 1$

18. The domain of $\frac{g}{f}$ 18. _____
- $\left(-\infty, \frac{4}{5}\right) \cup \left(\frac{4}{5}, \infty\right)$
 - $\left(-\infty, \frac{5}{4}\right) \cup \left(\frac{5}{4}, \infty\right)$
 - $\left(-\infty, \frac{1}{3}\right) \cup \left(\frac{1}{3}, \infty\right)$
 - $(-\infty, \infty)$

19. $\frac{f(x+h) - f(x)}{h}$ 19. _____
- h
 - 5
 - $5x + 2h$
 - $5x + 2h - 4$

20. $(f + g)(-1)$ 20. _____
- 1
 - 5
 - 2
 - 5

CHAPTER 2, FORM E

21. $\left(\frac{f}{g}\right)(0)$

a. $-\frac{3}{4}$

b. $\frac{1}{4}$

c. $-\frac{4}{3}$

d. $\frac{15}{2}$

21. _____

22. $(g \circ f)(x)$

a. $25x^2 + 40x - 19$

b. $25x^2 - 40x + 19$

c. $25x^2 - 40x - 19$

d. $25x^2 + 40x + 19$

22. _____

23. $(g \circ f)(1)$

a. -6

b. 4

c. 0

d. 1

23. _____

24. $(f \circ g)(x)$

a. $5x^2 - 11$

b. $5x^2 + 11$

c. $5x^2 + 19$

d. $5x^2 - 12$

24. _____

25. $(f \circ g)(0)$

a. -1

b. 0

c. 11

d. 15

25. _____

**CHAPTER 2, FORM F
COLLEGE ALGEBRA AND TRIGONOMETRY**

NAME _____
DATE _____

Choose the best answer.

1a. Which of the following is the domain of $f(x) = \sqrt{x-1}$? 1a. _____

- a. $[0,1]$ b. $(-\infty,1]$
c. $[1,\infty)$ d. $(-\infty,\infty)$

1b. Which of the following is the range of $f(x) = x^2 - 4$? 1b. _____

- a. $[-2,\infty)$ b. $[-4,\infty)$
c. $[-4,4]$ d. $[0,\infty)$

1c. Which of the following is the domain of $f(x) = \sqrt[3]{x-7}$? 1c. _____

- a. $(-\infty,\infty)$ b. $(-\infty,3]$
c. $[0,\infty)$ d. $[3,\infty)$

1d. Which of the following is the range of $f(x) = |x| + 2$? 1d. _____

- a. $[-2,2]$ b. $[0,2]$
c. $[2,\infty)$ d. $[0,\infty)$

1e. Which of the following is the domain of $x = y^2$? 1e. _____

- a. $(-\infty,\infty)$ b. $[0,\infty)$
c. $(0,\infty)$ d. $(-\infty,0]$

The graph shows the line that passes through $(-7, -4)$ and $(3, -2)$. Refer to it to answer Exercises 2-6.

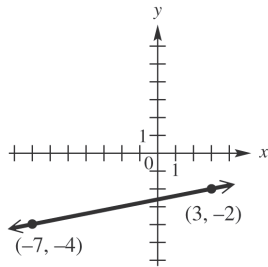

2. What is the slope of the line? 2. _____

- a. 0 b. $-\frac{1}{5}$
c. $\frac{1}{5}$ d. 5

3. What is the distance between the two points shown? 3. _____

- a. $\sqrt{122}$ b. $2\sqrt{26}$
c. $2\sqrt{13}$ d. $2\sqrt{34}$

CHAPTER 2, FORM F

4. What are the coordinates of the midpoint of the *segment* joining the two points?

- a. $\left(\frac{1}{2}, -\frac{11}{2}\right)$ b. $(-2, -1)$
 c. $(-5, -1)$ d. $(-2, -3)$

4. _____

5. Find the standard form of the equation of the line.

- a. $5x - y = 17$ b. $5x + y = -17$
 c. $x - 5y = 13$ d. $x + 5y = -13$

5. _____

6. Find the standard form of the equation of the line.

- a. $f(x) = \frac{1}{5}x - \frac{13}{5}$ b. $f(x) = -5x + 17$
 c. $f(x) = 5x - 17$ d. $f(x) = \frac{1}{5}x + \frac{13}{5}$

6. _____

Tell whether each graph is that of a function. Give the domain and range.

7.

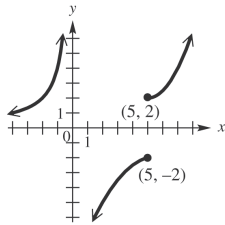

7. _____

- a. not a function; domain: $(-\infty, 0) \cup (0, \infty)$; range: $(-\infty, -2] \cup (0, \infty)$
 b. not a function; domain: $(-\infty, \infty)$; range: $(-\infty, \infty)$
 c. not a function; domain: $(-\infty, 0) \cup (0, \infty)$; range: $(-\infty, \infty)$
 d. not a function; domain: $(-\infty, 0) \cup (0, \infty)$; range: $(-\infty, -2] \cup (2, \infty)$

8.

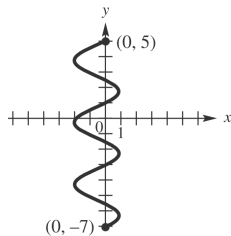

8. _____

- a. not a function; domain: $[-2, 1]$; range: $(-\infty, \infty)$
 b. not a function; domain: $[-7, 5]$; range: $[-2, 1]$
 c. not a function; domain: $[-7, 5]$; range: $(-\infty, \infty)$
 d. not a function; domain: $[-2, 1]$; range: $[-7, 5]$

CHAPTER 2, FORM F

9. Suppose point P has coordinates $(-3, 6)$.

What is the equation of the horizontal line through P ?

- a. $x = -3$ b. $y = -3$
 c. $x = 6$ d. $y = 6$

9. _____

10. Find the slope-intercept form of the equation of the line passing

through $(1, 2)$ perpendicular to the graph of $y = -\frac{1}{8}x + \frac{1}{3}$.

- a. $y = 8x - 3$ b. $y = \frac{1}{8}x - \frac{1}{3}$
 c. $y = -8x + 3$ d. $y = -\frac{1}{8}x + \frac{17}{8}$

10. _____

Graph each relation.

11. $f(x) = \frac{1}{2}|x+1|$

11. _____

a.

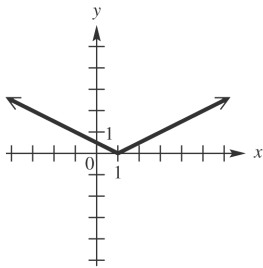

b.

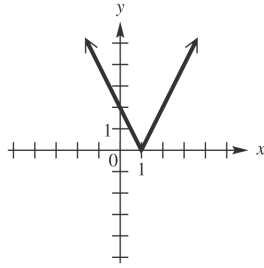

c.

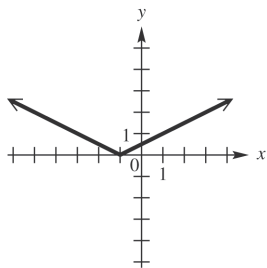

d.

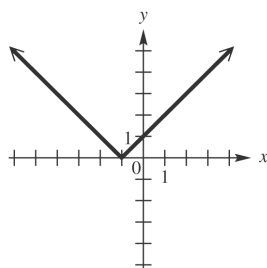

CHAPTER 2, FORM F

12. $f(x) = \left\lfloor \frac{1}{2}x \right\rfloor - 2$

a.

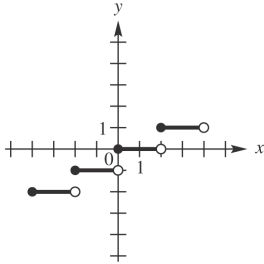

b.

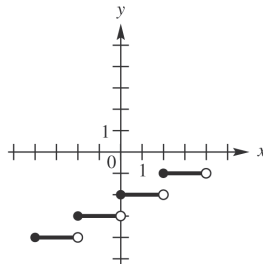

c.

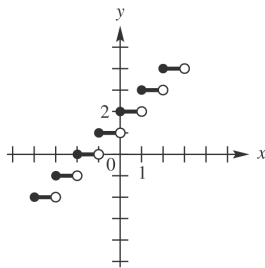

d.

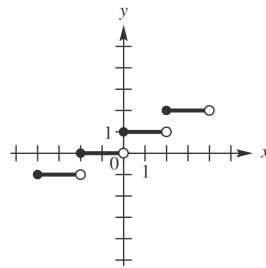

12. _____

13. $f(x) = \begin{cases} -2x & \text{if } x < -1 \\ x+3 & \text{if } x \geq -1 \end{cases}$

a.

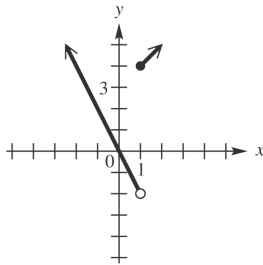

b.

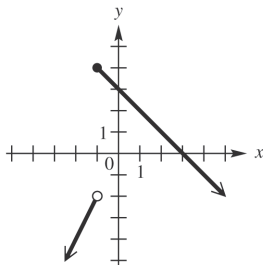

c.

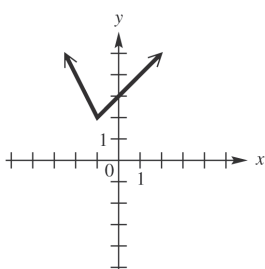

d.

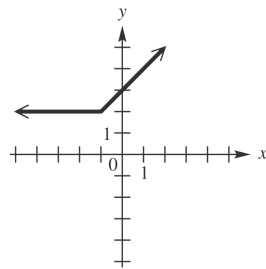

13. _____

14. Explain how the graph of $y = \sqrt{x+3} + 1$ can be obtained from the graph of $y = \sqrt{x}$.

- a. Translate 3 units to the right and 1 units up.
- b. Translate 3 units to the right and 1 units down.
- c. Translate 3 units to the left and 1 units up.
- d. Translate 3 units to the left and 1 units down.

14. _____

CHAPTER 2, FORM F

15. Determine the symmetries of the graph of the relation $4x^2 + 9y^2 = 36$.

- a. x -axis only
- b. y -axis only
- c. Origin only
- d. x -axis, y -axis, and origin

15. _____

Given $f(x) = 6x^2 + 5x - 6$ and $g(x) = 2x - 8$, find each of the following.
Simplify the expressions when possible.

16. $f(-3)$

- a. -9
- b. 21
- c. 33
- d. 51

16. _____

17. $\frac{f(x+h) - f(x)}{h}$

- a. $12x + 6h + 5$
- b. $12x - 6h - 5$
- c. $-12x + 6h + 5$
- d. $-12x + 6h - 5$

17. _____

18. $(f \circ g)\left(\frac{3}{2}\right)$

- a. -131
- b. 119
- c. -181
- d. 169

18. _____

19. $(f + g)(x)$

- a. $6x^2 + 7x - 14$
- b. $6x^2 - 7x - 14$
- c. $6x^2 + 7x - 2$
- d. $6x^2 - 3x - 2$

19. _____

20. $(f + g)(0)$

- a. -15
- b. -14
- c. -27
- d. 1

20. _____

MULTIPLE CHOICE. Choose the one alternative that best completes the statement or answers the question.

List the ordered pairs from the table.

1)

x	y
-5	-7
-4	-5
-2	-1
-1	1

- A) (-5, 1), (-4, -1), (-2, -5), (-1, -7)
 C) (-5, -7), (-4, -5), (-2, -1), (-1, 1)

- B) (-7, -5), (-5, -4), (-1, -2), (1, -1)
 D) (-5, -5), (-4, -7), (-2, 1), (-1, -1)

Answer: C

2)

Sales at the University Bookstore

Month	Sales
1	\$670,000
2	\$190,000
3	\$1,090,000
4	\$320,000

- A) (670,000, 1), (190,000, 2), (1,090,000, 3), (320,000, 4)
 B) (1, 670,000), (2, 190,000), (3, 1,090,000), (4, 320,000)
 C) (1, 190,000), (2, 670,000), (3, 320,000), (4, 1,090,000)
 D) (320,000, 1), (1,090,000, 2), (190,000, 3), (670,000, 4)

Answer: B

For the points P and Q, find the distance d(P, Q).

3) P(2, 7), Q(-1, -3)

- A) -7
 B) $\sqrt{109}$
 C) $\sqrt{91}$
 D) 30

Answer: B

4) P(5, -5), Q(7, -1)

- A) $12\sqrt{3}$
 B) 2
 C) 12
 D) $2\sqrt{5}$

Answer: D

5) P(-5, -1), Q(7, -4)

- A) 15
 B) $3\sqrt{17}$
 C) $135\sqrt{15}$
 D) 135

Answer: B

6) P(5, 6), Q(-1, 3)

- A) 3
 B) $27\sqrt{3}$
 C) 27
 D) $3\sqrt{5}$

Answer: D

7) P($9\sqrt{11}$, $-2\sqrt{7}$), Q($-3\sqrt{11}$, $-7\sqrt{7}$)

- A) $\sqrt{167}$
 B) $\sqrt{1759}$
 C) 1759
 D) 167

Answer: B

For the points P and Q, find the coordinates of the midpoint of the segment PQ.

8) P(0, 5), Q(4, 1)

- A) (2, 3)
 B) (-2, 2)
 C) (4, 6)
 D) (-4, 4)

Answer: A

9) P(7, -8), Q(-7, 4)

A) (0, -4)

B) (14, -12)

C) (0, -2)

D) (7, -6)

Answer: C

10) P(-5, -7), Q(1, 8)

A) (-6, -15)

B) $\left(-3, -\frac{15}{2}\right)$

C) $\left(-2, \frac{1}{2}\right)$

D) (-4, 1)

Answer: C

11) P(-8, -5), Q(-2, -1)

A) (-5, -3)

B) (-10, -6)

C) (-3, -2)

D) (-6, -4)

Answer: A

12) P($11\sqrt{5}$, $-\sqrt{10}$), Q($-\sqrt{5}$, 0)

A) $\left(5\sqrt{10}, -\frac{\sqrt{30}}{2}\right)$

B) (-5, 10)

C) $\left(5\sqrt{5}, -\frac{\sqrt{10}}{2}\right)$

D) $\left(6\sqrt{5}, \frac{\sqrt{10}}{2}\right)$

Answer: C

13) P($5\sqrt{5}$, $\sqrt{11}$), Q($-\sqrt{5}$, $4\sqrt{11}$)

A) $\left(2\sqrt{10}, -\frac{\sqrt{33}}{2}\right)$

B) $(2\sqrt{5}, 5\sqrt{11})$

C) $\left(3\sqrt{5}, \frac{\sqrt{11}}{2}\right)$

D) $\left(2\sqrt{5}, \frac{5\sqrt{11}}{2}\right)$

Answer: D

14) P($-\sqrt{10}$, 1), Q(0, $\sqrt{3}$)

A) $(-\sqrt{10}, 1 + \sqrt{3})$

B) $\left(\frac{\sqrt{10}}{2}, \frac{1 - \sqrt{3}}{2}\right)$

C) $\left(-\frac{\sqrt{10}}{2}, \frac{1 + \sqrt{3}}{2}\right)$

D) $\left(\frac{-\sqrt{10} + \sqrt{3}}{2}, \frac{1}{2}\right)$

Answer: C

Determine whether the three points are the vertices of a right triangle.

15) (-5, 2), (0, 2), (0, 4)

A) Yes

B) No

Answer: A

16) (5, 6), (7, 10), (9, 9)

A) Yes

B) No

Answer: A

17) (-7, 4), (-1, 6), (3, -6)

A) Yes

B) No

Answer: A

18) (9, 6), (15, 8), (14, 3)

A) Yes

B) No

Answer: B

19) (-6, -6), (0, -4), (6, -11)

A) Yes

B) No

Answer: B

20) $(-9, 9), (2, -2), (4, 0)$

A) Yes

B) No

Answer: A

Determine whether the three points are collinear.

21) $(-2, 6), (6, 4), (-10, 8)$

A) Yes

B) No

Answer: A

22) $(0, -12), (-1, -3), (-9, -11)$

A) Yes

B) No

Answer: B

23) $(-5, -11), (4, 7), (5, 9)$

A) Yes

B) No

Answer: A

24) $(7, -3), (-3, 6), (1, 1)$

A) Yes

B) No

Answer: B

Find the coordinates of the other endpoint of the segment, given its midpoint and one endpoint.

25) midpoint $(5, 9)$, endpoint $(2, 4)$

A) $(-4, -6)$

B) $(12, 10)$

C) $(8, 14)$

D) $(8, -1)$

Answer: C

26) midpoint $(0, -5)$, endpoint $(2, -4)$

A) $(-2, -6)$

B) $(0, -8)$

C) $(-2, -3)$

D) $(6, -2)$

Answer: A

27) midpoint $(0, 3)$, endpoint $(-4, 8)$

A) $(4, 13)$

B) $(-12, 18)$

C) $(-14, 16)$

D) $(4, -2)$

Answer: D

28) midpoint $(7, 13)$, endpoint $(10, 9)$

A) $(18, 3)$

B) $(4, 5)$

C) $(16, 1)$

D) $(4, 17)$

Answer: D

29) midpoint (b, x) , endpoint (m, q)

A) $(2b - m, 2x - q)$

B) $\left(\frac{b+m}{2}, \frac{x+q}{2}\right)$

C) $(2m - b, 2q - x)$

D) $(b - m, x - q)$

Answer: A

30) midpoint $\left(\frac{p+b}{2}, \frac{q-y}{2}\right)$, endpoint (p, q)

A) $\left(\frac{b}{2}, -\frac{y}{2}\right)$

B) (b, y)

C) $(b, -y)$

D) $\left(\frac{3p+b}{4}, \frac{3q-y}{4}\right)$

Answer: C

Solve the problem.

- 31) The graph shows an idealized linear relationship for the average monthly payment to retirees from 1995 to 1999. Use the midpoint formula to estimate the average payment in 1997.

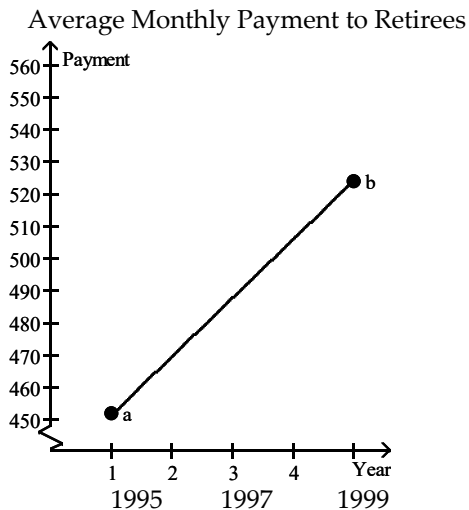

- A) \$488 B) \$36 C) \$500 D) \$524

Answer: A

- 32) The table lists how financial aid income cutoffs (in dollars) for a family of four have changed over time. Use the midpoint formula to approximate the financial aid cutoff for 1985.

Year	Income (in dollars)
1960	20,500
1970	26,000
1980	31,500
1990	37,000
2000	42,500

- A) \$53,500 B) \$17,750 C) \$34,250 D) \$20,500

Answer: C

- 33) The table shows enrollment in 2-year technical schools for 1980, 1990 and 2000. Assuming a linear relationship, estimate the enrollment for 1995.

Year	Enrollment (in millions)
1980	2.2
1990	2.7
2000	3.2

- A) 4.65 million B) 2.95 million C) 2.2 million D) 1.25 million

Answer: B

Graph the equation by determining the missing values needed to plot the ordered pairs.

34) $y + x = 4$; (1,), (4,), (3,)

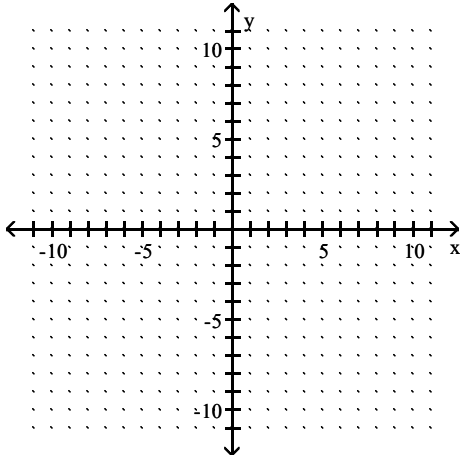

A)

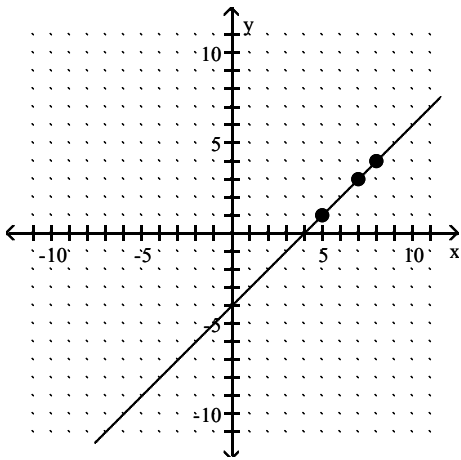

C)

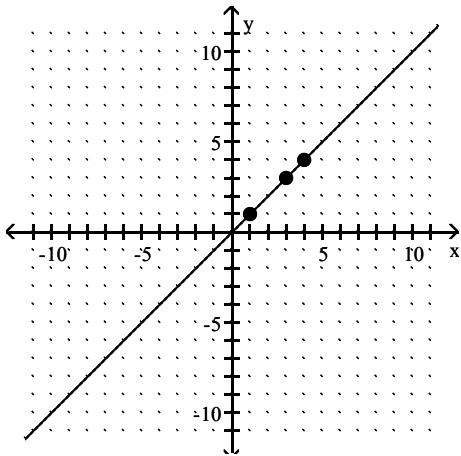

B)

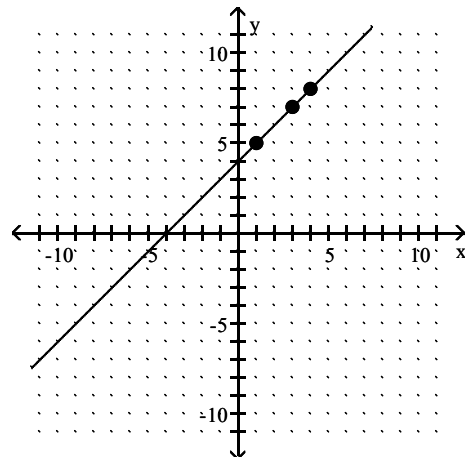

D)

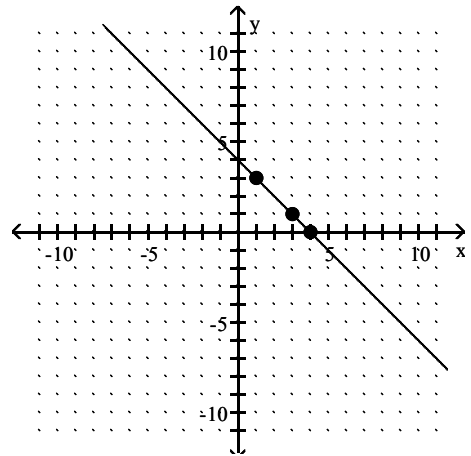

Answer: D

35) $y - x = 1$; (3,), (, 8), (4,)

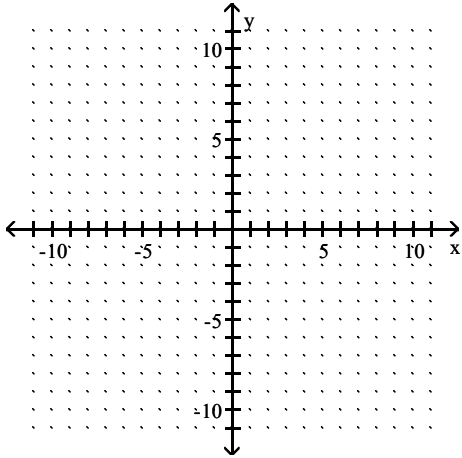

A)

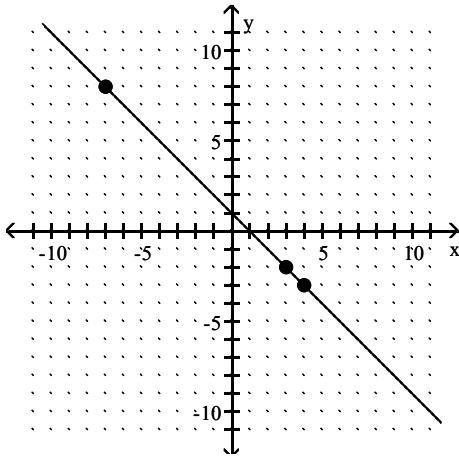

B)

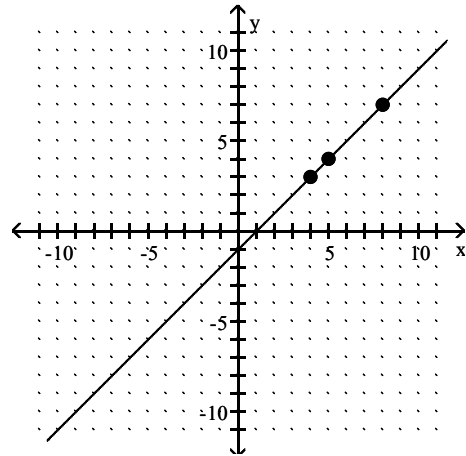

C)

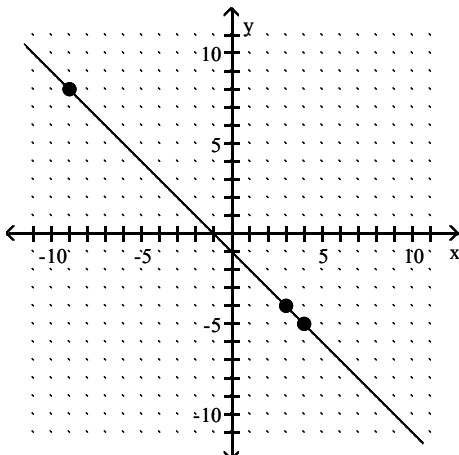

D)

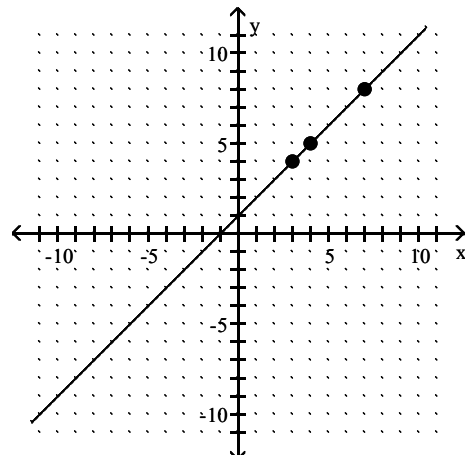

Answer: D

36) $x + 3y = 6$; $(0, \quad), (\quad, 0), (1, \quad), (\quad, 1)$

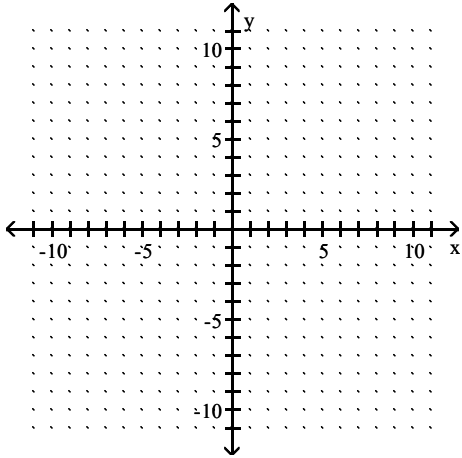

A)

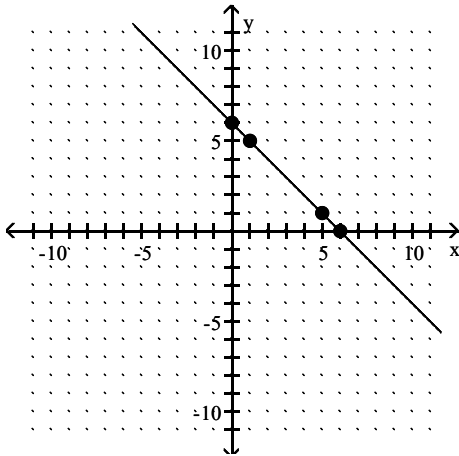

B)

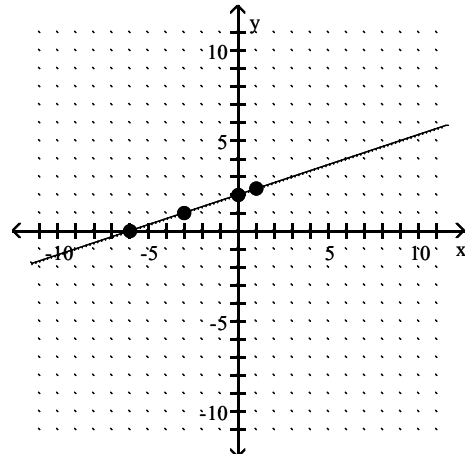

C)

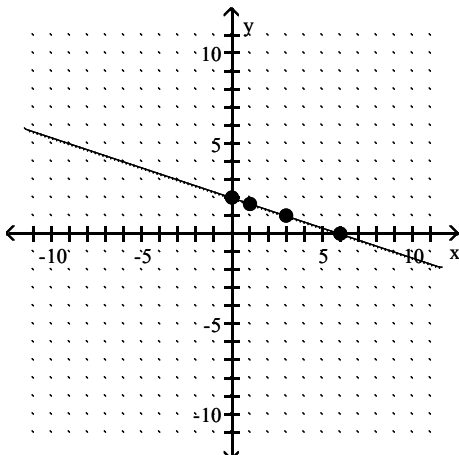

D)

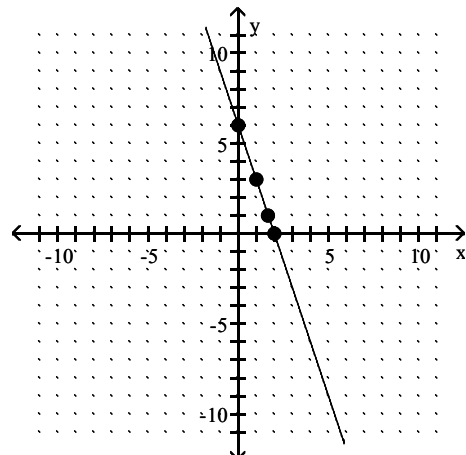

Answer: C

37) $4x - 5y = -20$; $(0, \quad)$, $(\quad, 0)$, $(-1, \quad)$

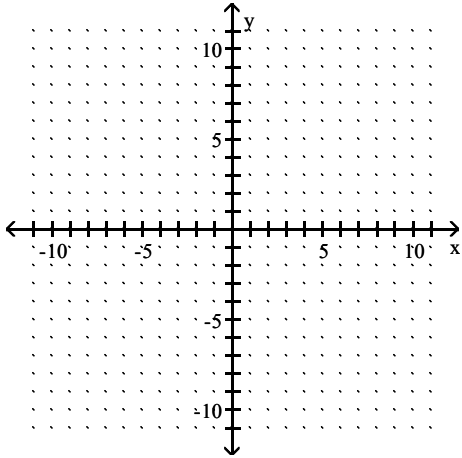

A)

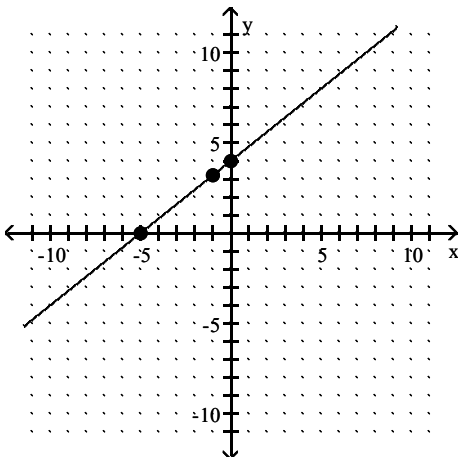

C)

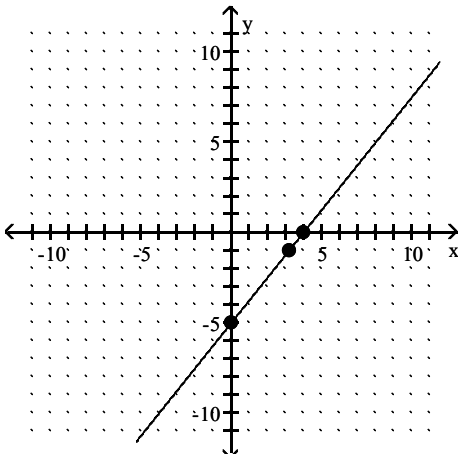

B)

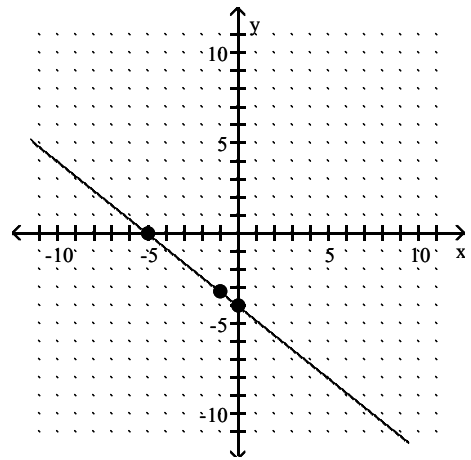

D)

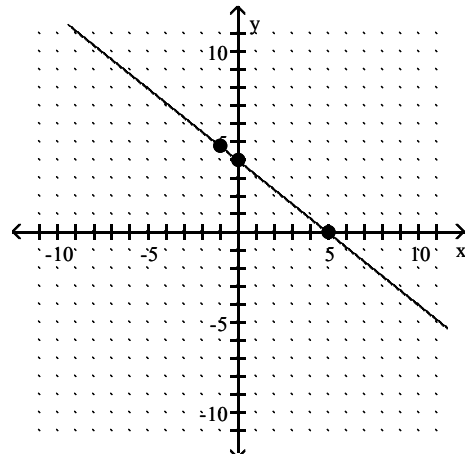

Answer: A

38) $4y = -2x + 8$; $(0, \quad), (\quad, 0), (1, \quad)$

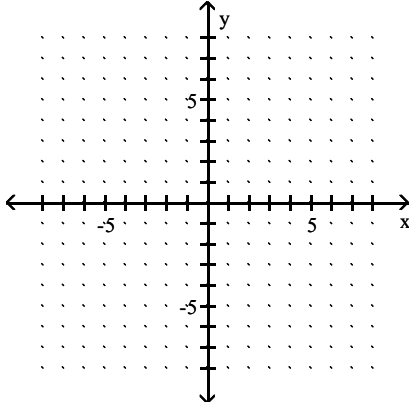

A)

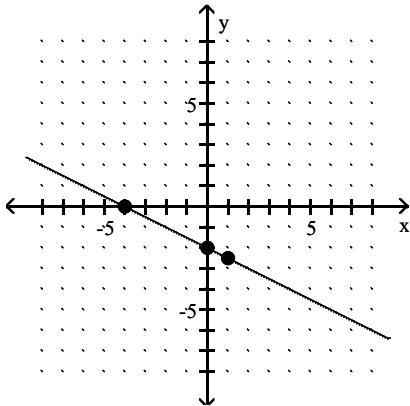

C)

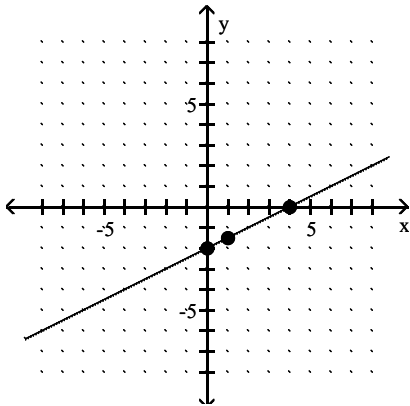

B)

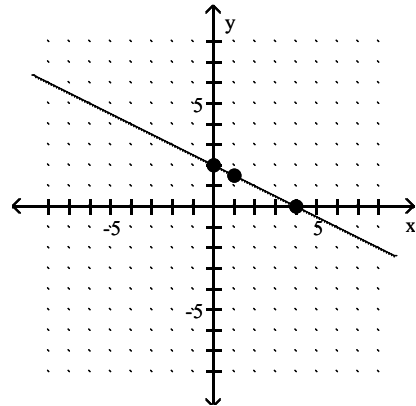

D)

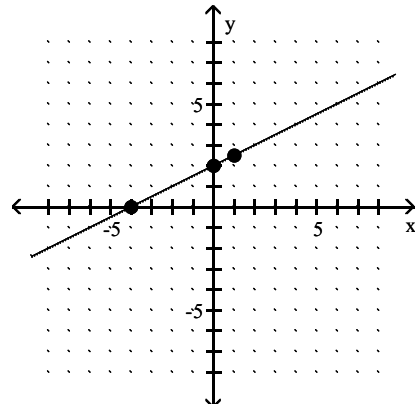

Answer: B

Graph the equation by plotting points.

39) $y = \sqrt{x+1}$

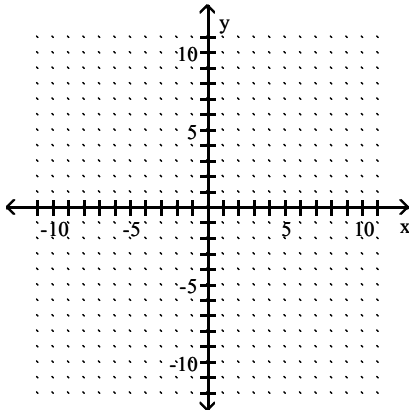

A)

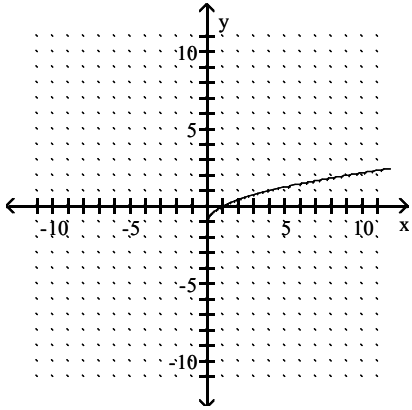

C)

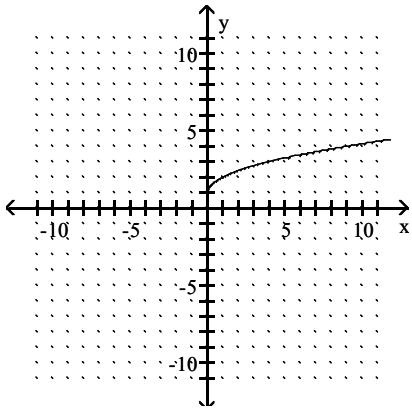

B)

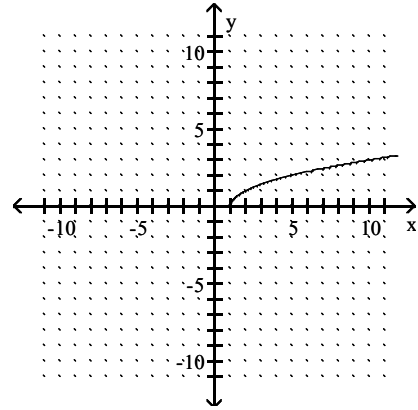

D)

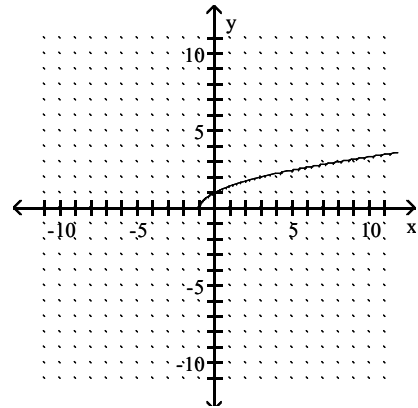

Answer: D

40) $y = \sqrt{x} + 3$

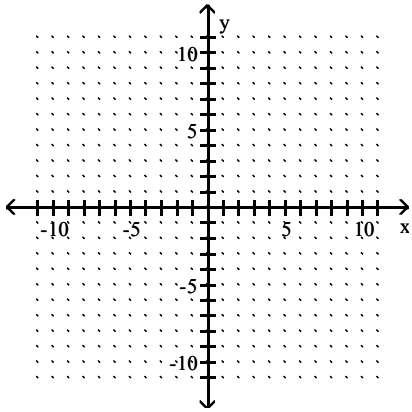

A)

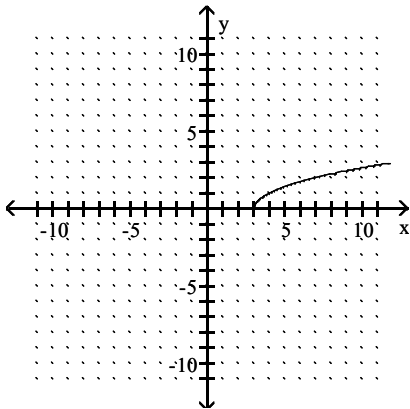

B)

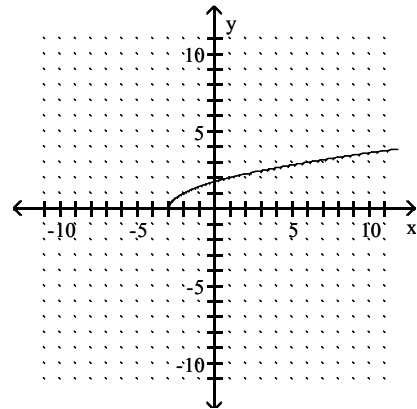

C)

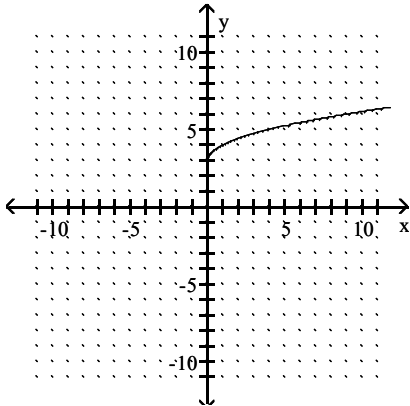

D)

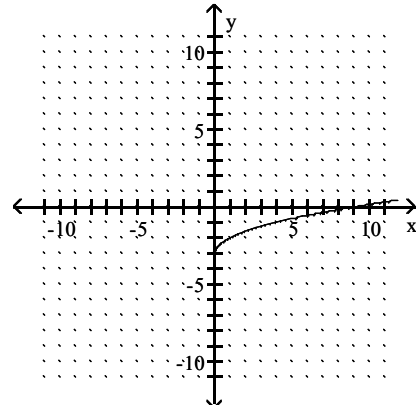

Answer: C

41) $y = x^2 - 2$

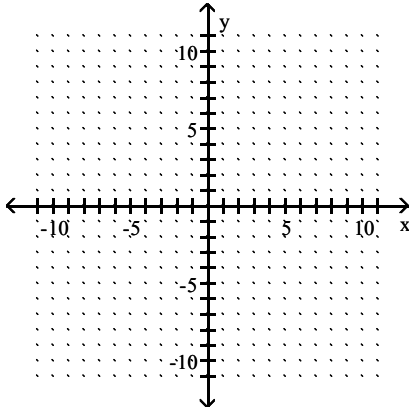

A)

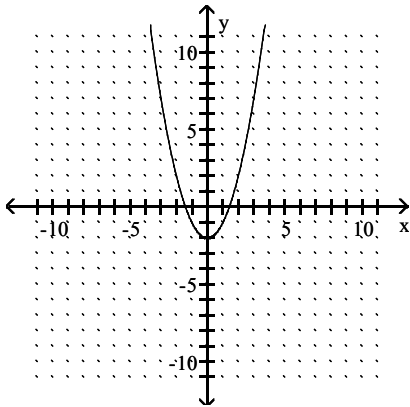

B)

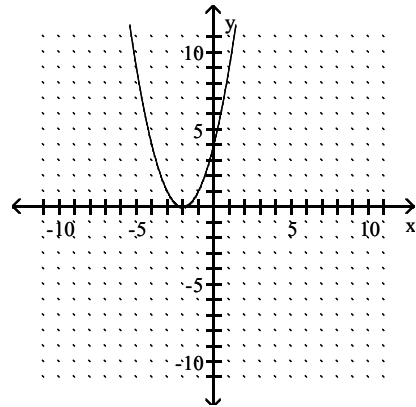

C)

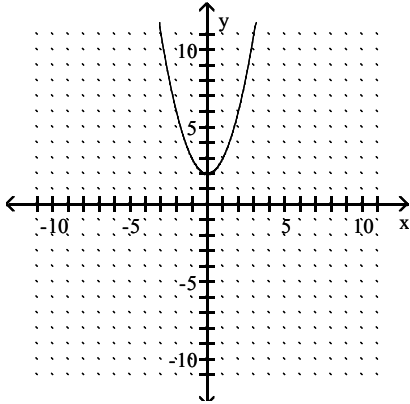

D)

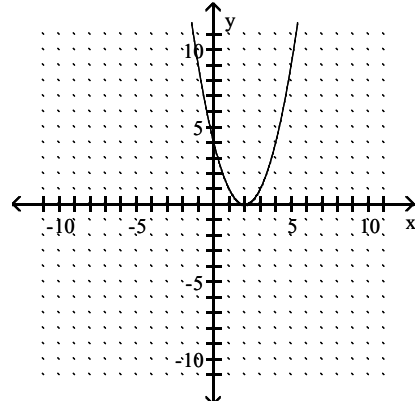

Answer: A

42) $y = |-2 - x|$

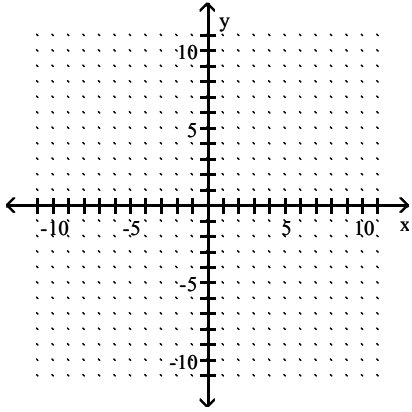

A)

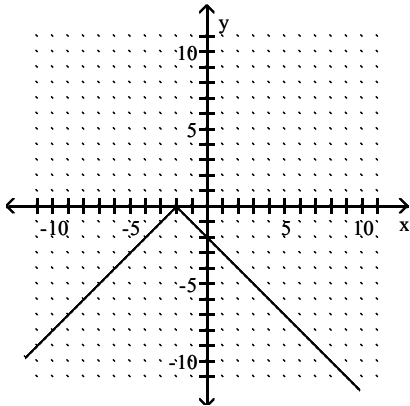

C)

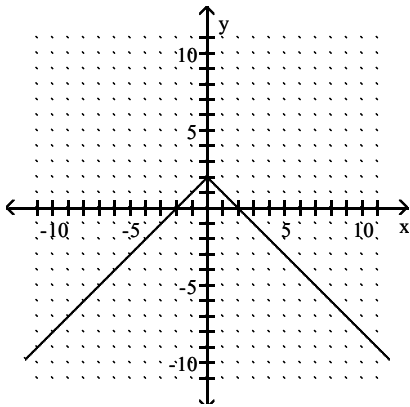

B)

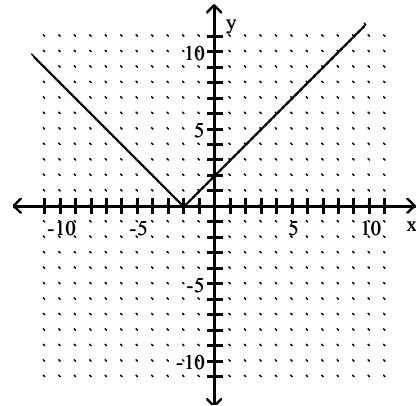

D)

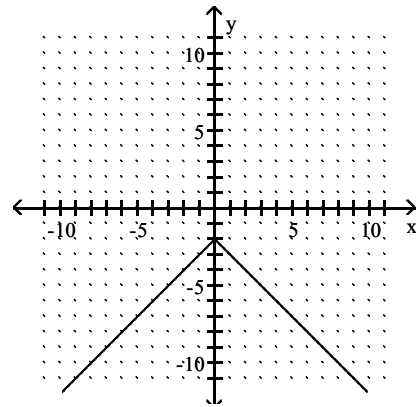

Answer: B

43) $y = |x| + 5$

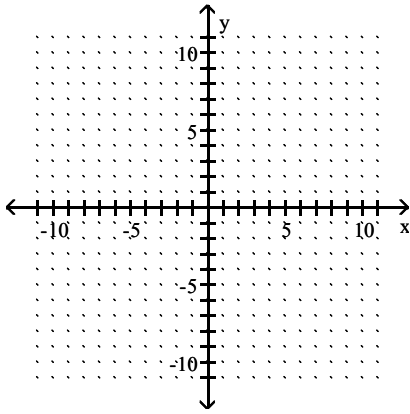

A)

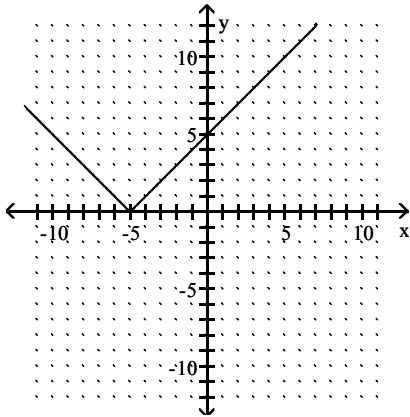

B)

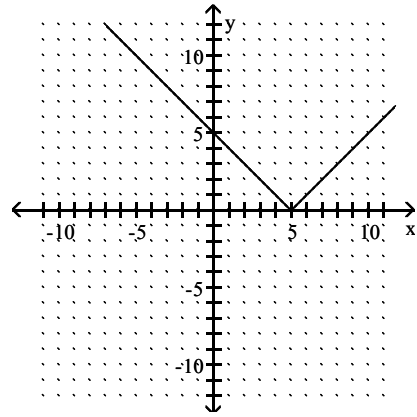

C)

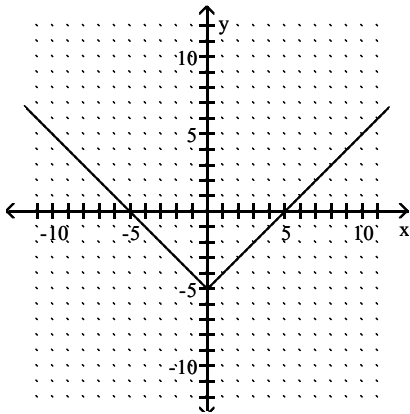

D)

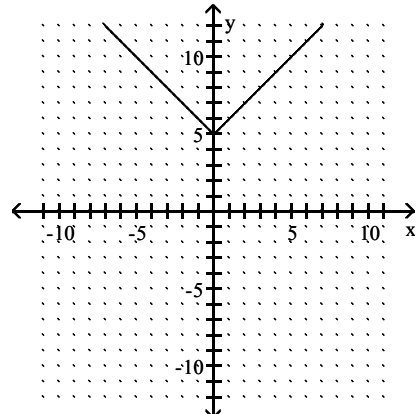

Answer: D

44) $y = -x^2 + 5$

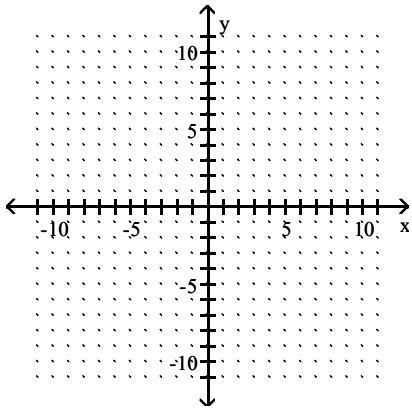

A)

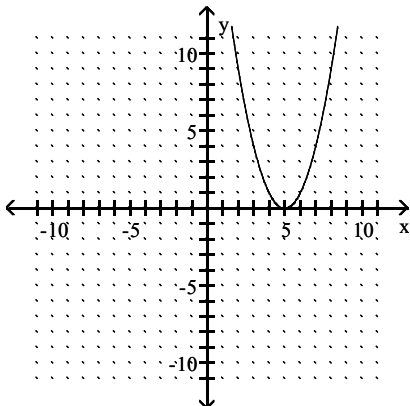

B)

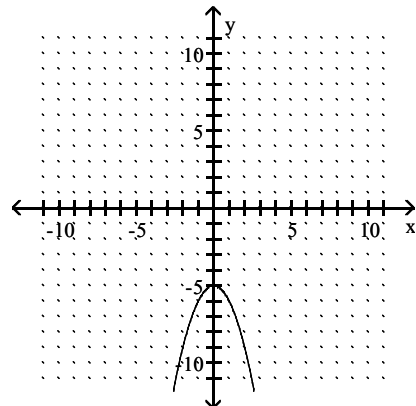

C)

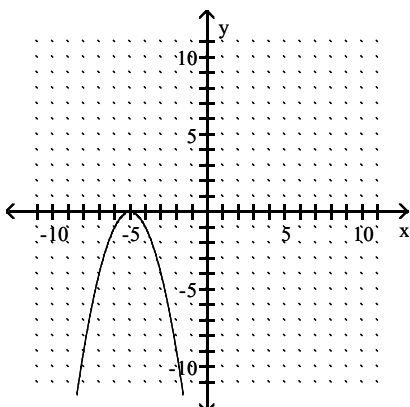

D)

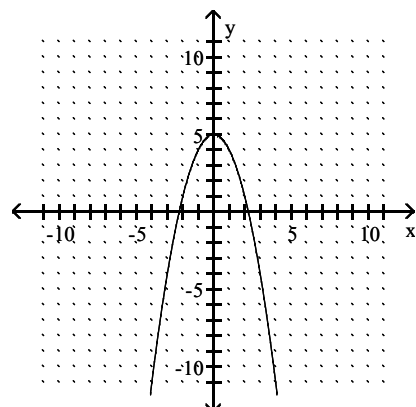

Answer: D

45) $y = x^3 + 5$

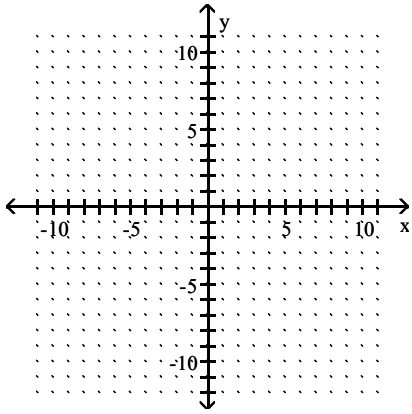

A)

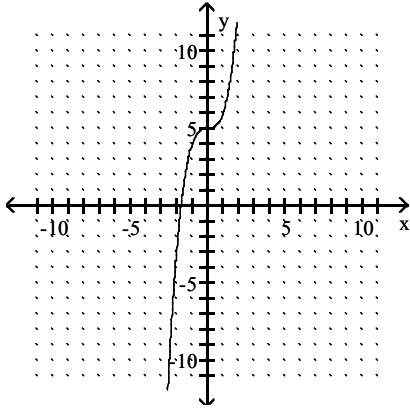

C)

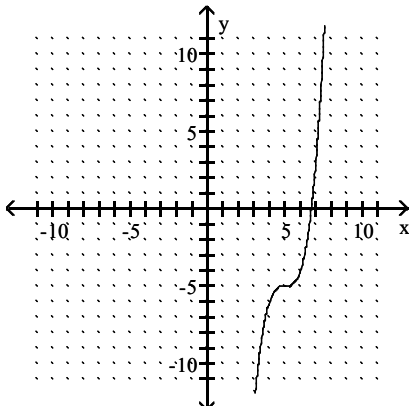

B)

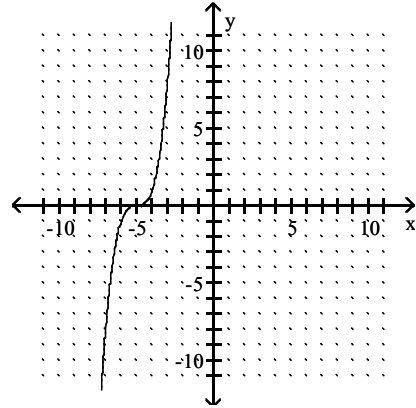

D)

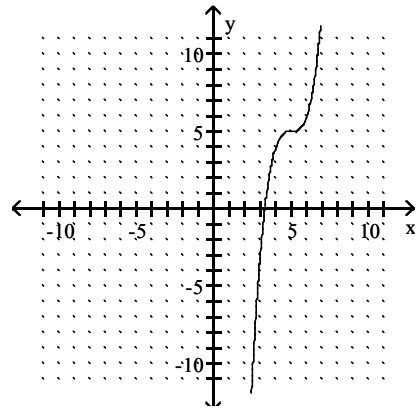

Answer: A

46) $y = (x + 2)^3$

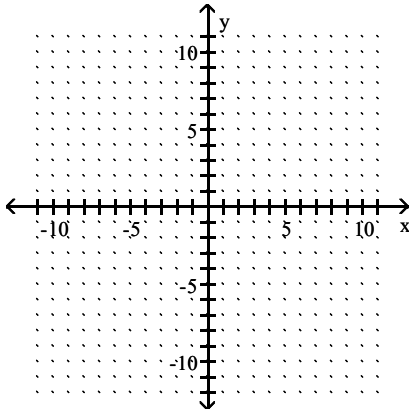

A)

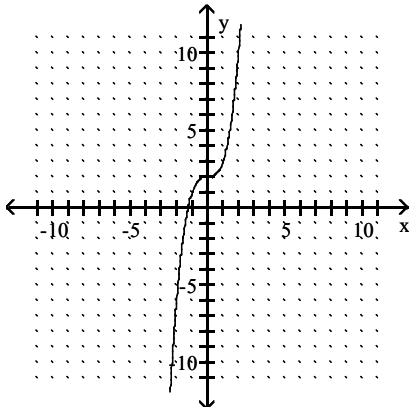

C)

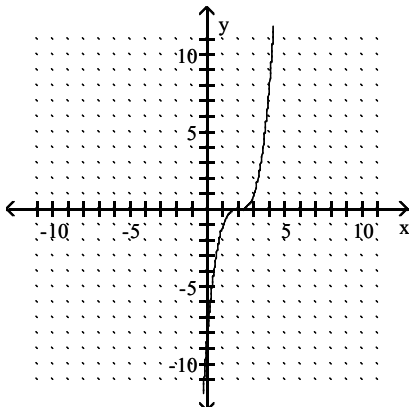

B)

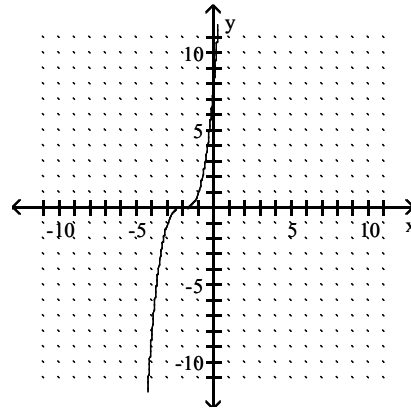

D)

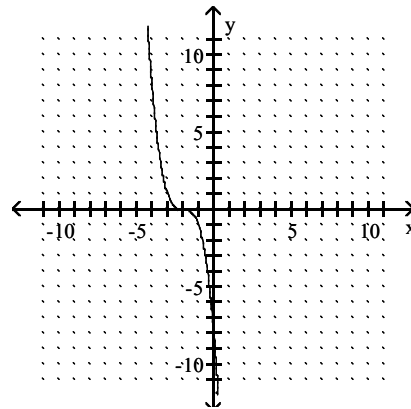

Answer: B

Provide an appropriate response.

47) If the point (a, b) is in the fourth quadrant, in what quadrant is $(a, -b)$?

A) II

B) IV

C) III

D) I

Answer: D

48) If the point (a, b) is in the fourth quadrant, in what quadrant is $(-a, -b)$?

A) IV

B) II

C) III

D) I

Answer: B

- 49) If the point (a, b) is in the fourth quadrant, in what quadrant is (b, a) ?
 A) III B) IV C) II D) I
 Answer: C

- 50) If a vertical line is drawn through the point $(-5, 6)$, where will it intersect the x -axis?
 A) $(0, 6)$ B) $(6, 0)$ C) $(-5, 0)$ D) $(0, -5)$
 Answer: C

- 51) If a horizontal line is drawn through the point $(5, -2)$, where will it intersect the y -axis?
 A) $(-2, 0)$ B) $(0, -2)$ C) $(5, 0)$ D) $(0, 5)$
 Answer: B

- 52) What is the midpoint of the segment joining (a, z) and $(-5a, 7z)$?
 A) $(-4a, 8z)$ B) $(-3a, 4z)$ C) $(-2a, 4z)$ D) $(2a, 3z)$
 Answer: C

- 53) What is the distance from the origin to the point $(m, -n)$?
 A) $\sqrt{m^2 + n^2}$ B) $\sqrt{m^2 - n^2}$ C) $m^2 + n^2$ D) $\sqrt{m - n}$
 Answer: A

- 54) What is the distance from the point (c, w) to the point (m, q) ?
 A) $\sqrt{(m - c)^2 + (q - w)^2}$ B) $[\sqrt{m - c} + \sqrt{q - w}]^2$
 C) $\sqrt{(m - c)^2 - (q - w)^2}$ D) $\sqrt{(c - w)^2 + (m - q)^2}$
 Answer: A

- 55) Are the points $A(1, 6)$, $B(4, 9)$, $C(6, 1)$, and $D(9, 4)$ the vertices of a parallelogram (opposite sides equal in length)? of a rhombus (all sides equal in length)?
 A) yes; yes B) no; no C) no; yes D) yes; no
 Answer: D

- 56) Are the points $A(-1, 12)$, $B(2, 9)$, $C(4, 1)$, and $D(7, 4)$ the vertices of a parallelogram (opposite sides equal in length)? of a rhombus (all sides equal in length)?
 A) yes; no B) no; yes C) yes; yes D) no; no
 Answer: D

Find the center-radius form of the equation of the circle.

- 57) center $(0, 0)$, radius 3
 A) $x^2 + y^2 = 3$ B) $x^2 + y^2 = 6$ C) $x^2 + y^2 = 9$ D) $x^2 + y^2 = \sqrt{3}$
 Answer: C

- 58) center $(-8, -10)$, radius 8
 A) $(x + 10)^2 + (y + 8)^2 = 8$ B) $(x + 8)^2 + (y + 10)^2 = 64$
 C) $(x - 10)^2 + (y - 8)^2 = 8$ D) $(x - 8)^2 + (y - 10)^2 = 64$
 Answer: B

- 59) center $(6, 0)$, radius 3
 A) $(x + 6)^2 + y^2 = 9$ B) $(x - 6)^2 + y^2 = 9$ C) $x^2 + (y + 6)^2 = 3$ D) $x^2 + (y - 6)^2 = 3$
 Answer: B

60) center (0, 6), radius 10

A) $(x - 6)^2 + y^2 = 100$

B) $x^2 + (y + 6)^2 = 10$

C) $x^2 + (y - 6)^2 = 100$

D) $(x + 6)^2 + y^2 = 100$

Answer: C

61) center (5, 7), radius $\sqrt{15}$

A) $(x + 7)^2 + (y + 5)^2 = 225$

B) $(x + 5)^2 + (y + 7)^2 = 15$

C) $(x - 7)^2 + (y - 5)^2 = 225$

D) $(x - 5)^2 + (y - 7)^2 = 15$

Answer: D

62) center (0, 2), radius $\sqrt{19}$

A) $(x + 2)^2 + y^2 = 361$

B) $x^2 + (y + 2)^2 = 19$

C) $(x - 2)^2 + y^2 = 361$

D) $x^2 + (y - 2)^2 = 19$

Answer: D

63) center (7, 0), radius $\sqrt{15}$

A) $x^2 + (y - 7)^2 = 225$

B) $(x - 7)^2 + y^2 = \sqrt{15}$

C) $(x + 7)^2 + y^2 = 15$

D) $(x - 7)^2 + y^2 = 15$

Answer: D

64) center $(-\sqrt{3}, -4)$, radius $\sqrt{3}$

A) $(x - \sqrt{3})^2 + (y - 4)^2 = 9$

B) $(x + \sqrt{3})^2 + (y + 4)^2 = 3$

C) $(x + \sqrt{3})^2 + (y + 4)^2 = \sqrt{3}$

D) $(x - \sqrt{3})^2 + (y - 4)^2 = 3$

Answer: B

Graph the circle.

65) $x^2 + y^2 = 36$

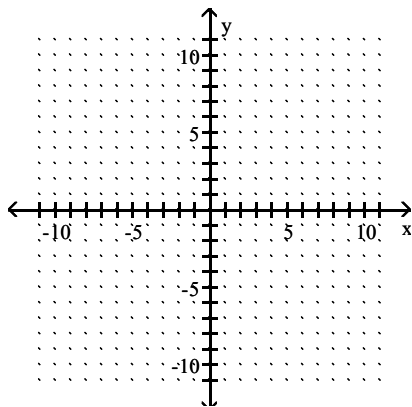

A)

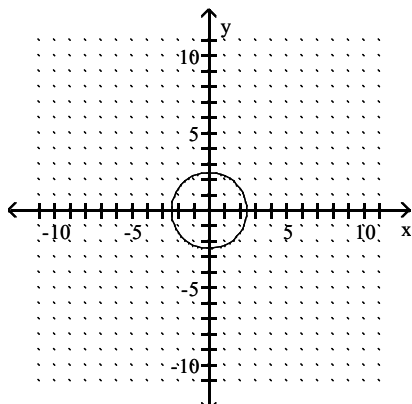

B)

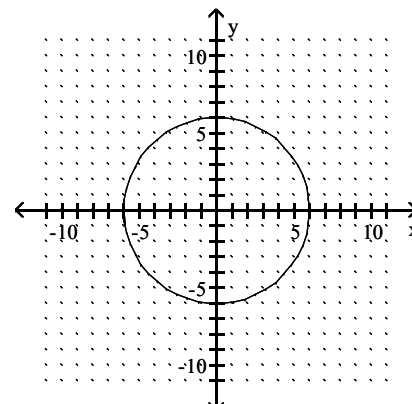

C)

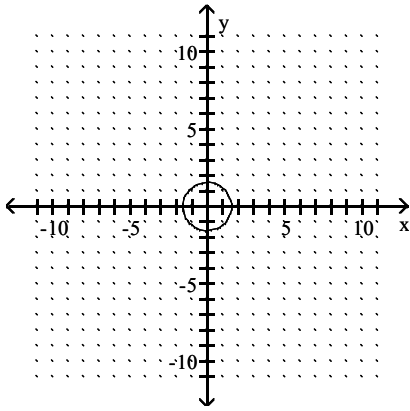

D)

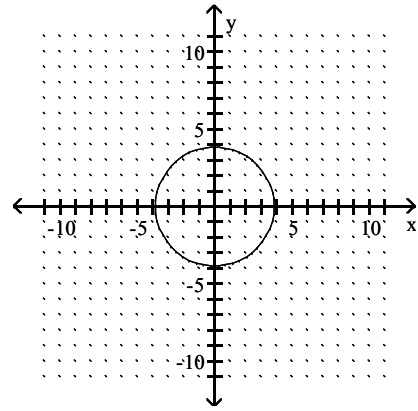

Answer: B

66) $(x - 4)^2 + (y + 1)^2 = 25$

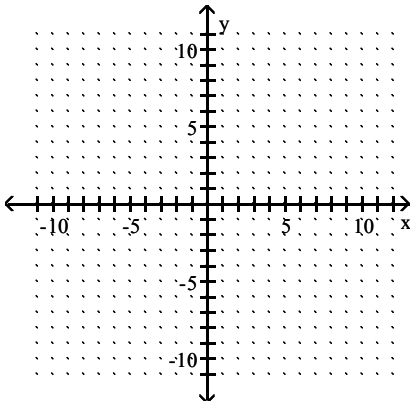

A)

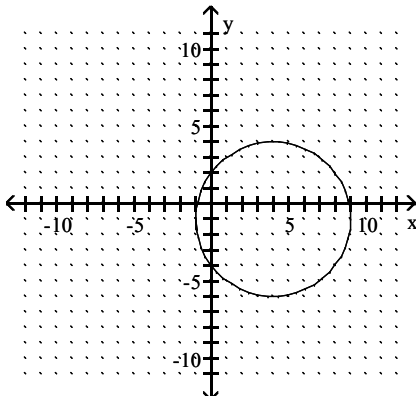

B)

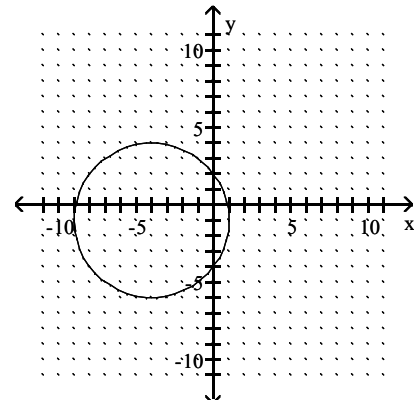

C)

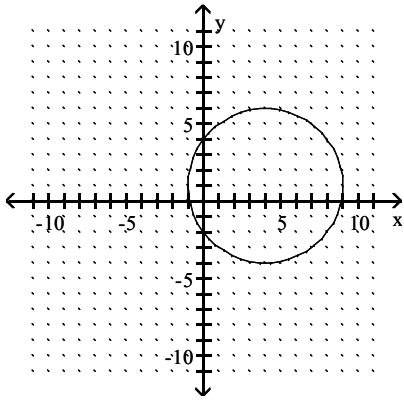

D)

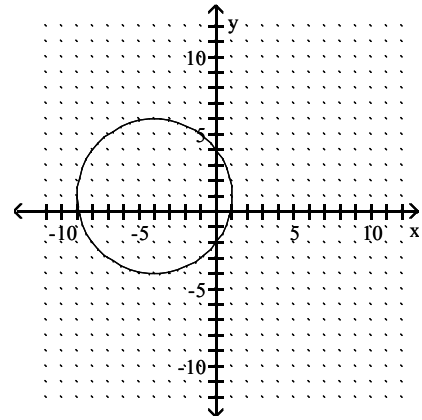

Answer: A

67) $(x - 4)^2 + (y - 4)^2 = 16$

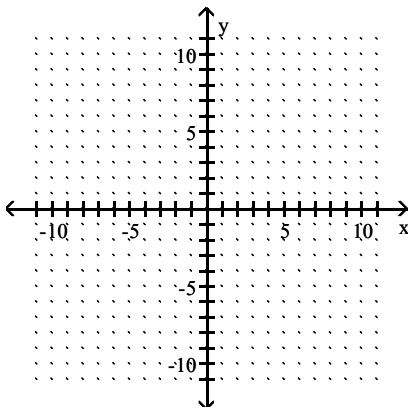

A)

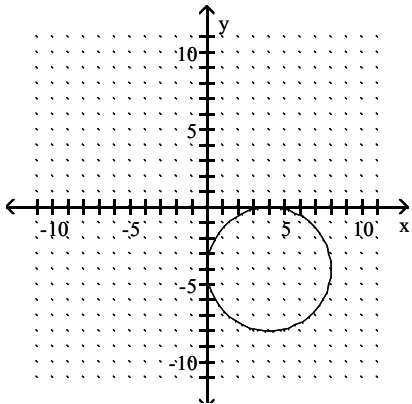

B)

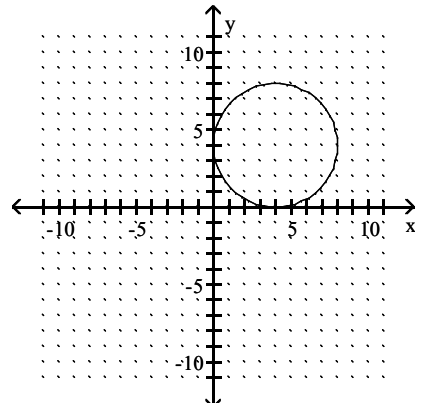

C)

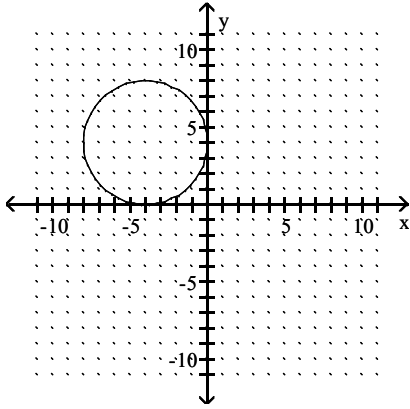

D)

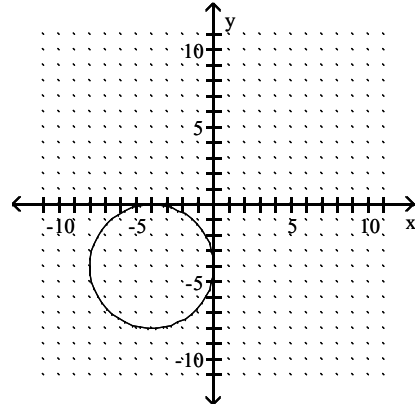

Answer: B

$$68) x^2 + (y - 6)^2 = 9$$

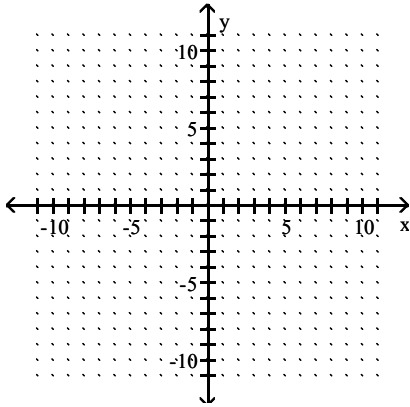

A)

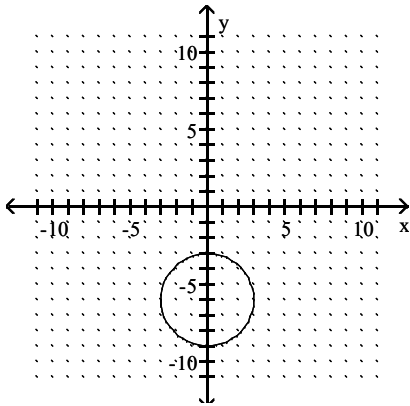

B)

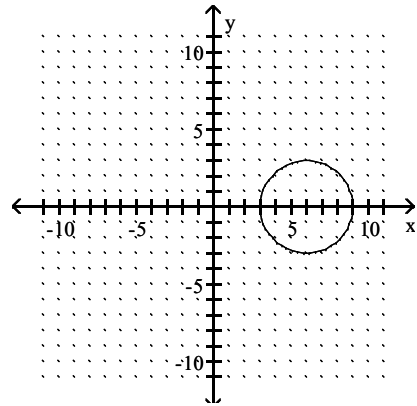

C)

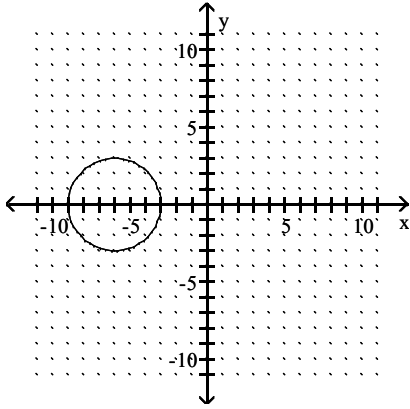

D)

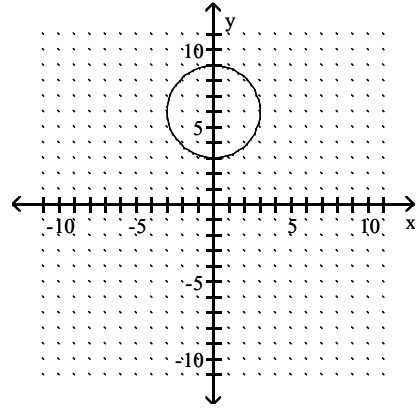

Answer: D

69) $(x - 3)^2 + y^2 = 4$

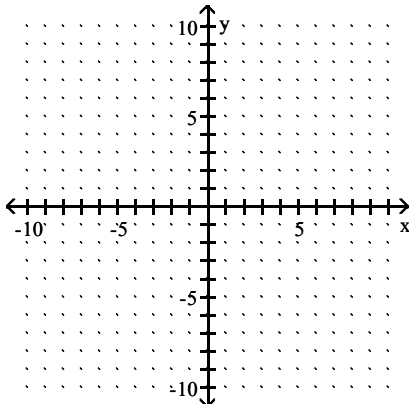

A)

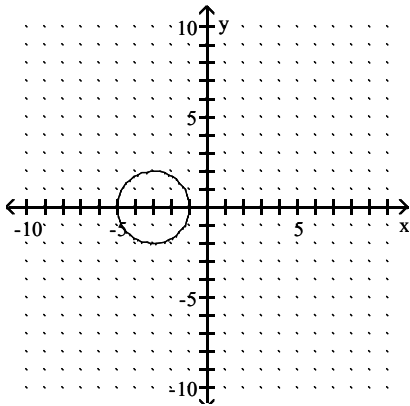

B)

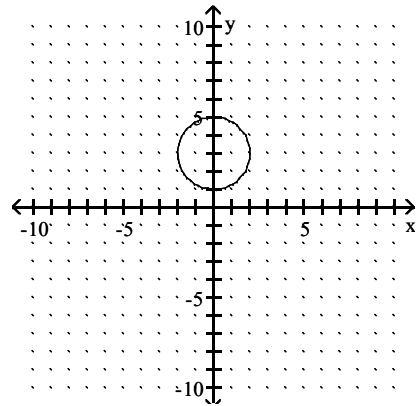

C)

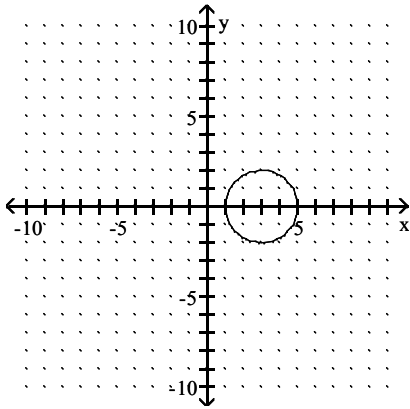

Answer: C

D)

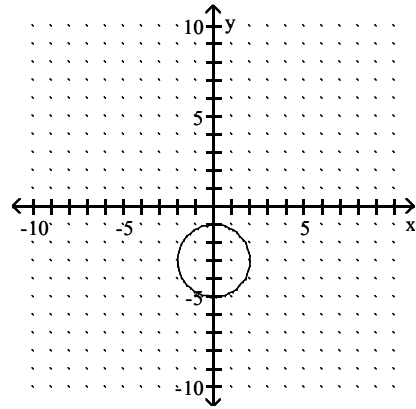

Use the graph to determine the equation of the circle in center-radius form.

70)

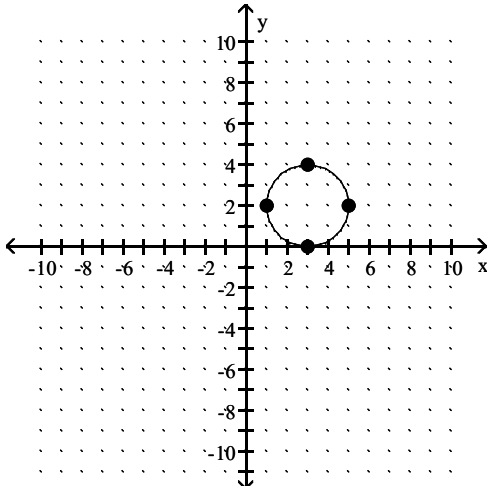

A) $(x + 3)^2 + (y + 2)^2 = 2$

C) $(x + 3)^2 + (y + 2)^2 = 4$

B) $(x - 3)^2 + (y - 2)^2 = 4$

D) $(x - 3)^2 + (y - 2)^2 = 2$

Answer: B

71)

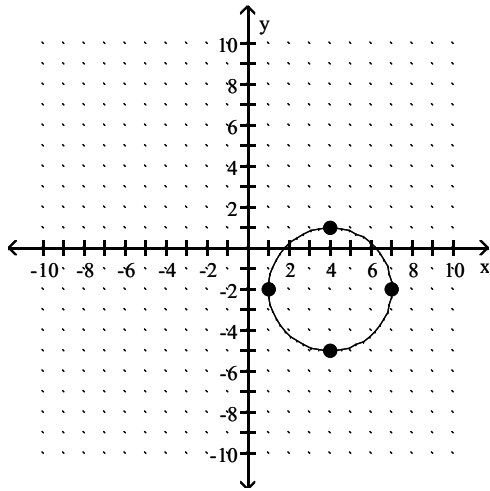

A) $(x + 4)^2 + (y - 2)^2 = 3$

C) $(x + 4)^2 + (y - 2)^2 = 9$

B) $(x - 4)^2 + (y + 2)^2 = 9$

D) $(x - 4)^2 + (y + 2)^2 = 3$

Answer: B

72)

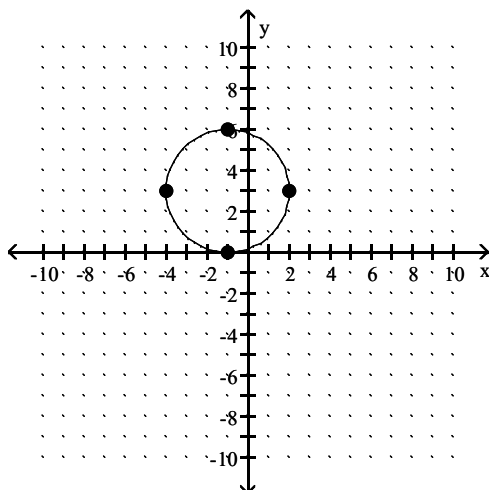

A) $(x + 1)^2 + (y - 3)^2 = 9$

C) $(x + 1)^2 + (y - 3)^2 = 3$

B) $(x - 1)^2 + (y + 3)^2 = 3$

D) $(x - 1)^2 + (y + 3)^2 = 9$

Answer: A

73)

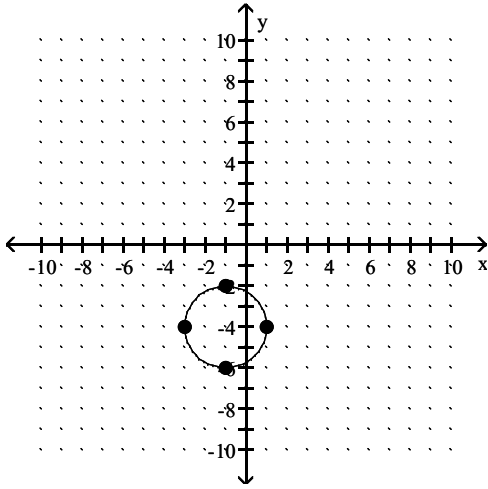

A) $(x - 1)^2 + (y - 4)^2 = 2$

B) $(x - 1)^2 + (y - 4)^2 = 4$

C) $(x + 1)^2 + (y + 4)^2 = 4$

D) $(x + 1)^2 + (y + 4)^2 = 2$

Answer: C

Decide whether or not the equation has a circle as its graph. If it does not, describe the graph.

74) $x^2 + y^2 + 16x - 4y + 52 = 0$

A) no; the graph is nonexistent

B) no; the graph is the point $(-8, 2)$

C) yes

D) no; the graph is the point $(8, -2)$

Answer: C

75) $x^2 + y^2 - 2x + 6y - 15 = 0$

A) yes

B) no; the graph is the point $(-1, 3)$

C) no; the graph is nonexistent

D) no; the graph is the point $(1, -3)$

Answer: A

76) $x^2 + y^2 - 6x + 8y + 25 = 0$

A) no; the graph is nonexistent

B) no; the graph is the point $(3, -4)$

C) yes

D) no; the graph is the point $(-3, 4)$

Answer: B

77) $x^2 + y^2 + 18x + 14y + 211 = 0$

A) no; the graph is nonexistent

B) no; the graph is the point $(9, 7)$

C) yes

D) no; the graph is the point $(-9, -7)$

Answer: A

78) $2x^2 + 2y^2 + 16x - 4y + 26 = 0$

A) no; the graph is the point $(-4, 1)$

B) yes

C) no; the graph is nonexistent

D) no; the graph is the point $(4, -1)$

Answer: B

Find the center and radius of the circle.

79) $x^2 + y^2 - 12x + 2y - 44 = 0$

A) center: $(-1, 6)$; radius: 9

C) center: $(6, -1)$; radius: 9

Answer: C

B) center: $(1, -6)$; radius: 81

D) center: $(-6, 1)$; radius: 81

80) $x^2 + y^2 + 10x - 8y - 8 = 0$

A) center: $(-4, 5)$; radius: 49

C) center: $(5, -4)$; radius: 49

Answer: B

B) center: $(-5, 4)$; radius: 7

D) center: $(4, -5)$; radius: 7

81) $x^2 + y^2 + 10x + 14y + 38 = 0$

A) center: $(5, 7)$; radius: 36

C) center: $(7, 5)$; radius: 36

Answer: D

B) center: $(-7, -5)$; radius: 6

D) center: $(-5, -7)$; radius: 6

82) $2x^2 + 2y^2 - 16x - 4y + 16 = 0$

A) center: $(4, 1)$, radius: 3

C) center: $(-4, -1)$, radius: 9

Answer: A

B) center: $(-1, -4)$, radius: 9

D) center: $(1, 4)$, radius: 3

Find the center-radius form of the circle described or graphed.

83) a circle having a diameter with endpoints $(-3, 4)$ and $(-3, -4)$

A) $x^2 + (y - 4)^2 = 9$

B) $(x - 4)^2 + y^2 = 9$

C) $(x + 3)^2 + y^2 = 16$

D) $(x + 3)^2 + y^2 = 4$

Answer: C

84) a circle having a diameter with endpoints $(-2, 8)$ and $(8, 2)$

A) $x^2 + (y - 5)^2 = 25$

B) $(x - 3)^2 + (y - 5)^2 = 34$

C) $(x - 5)^2 + (y - 3)^2 = 34$

D) $(x - 3)^2 + y^2 = 9$

Answer: B

85) a circle having a diameter with endpoints $(-6, -7)$ and $(-1, 2)$

A) $\left(x + \frac{7}{2}\right)^2 + \left(y + \frac{5}{2}\right)^2 = \frac{53}{2}$

B) $\left(x - \frac{7}{2}\right)^2 + \left(y - \frac{5}{2}\right)^2 = 74$

C) $\left(x + \frac{5}{2}\right)^2 + \left(y + \frac{9}{2}\right)^2 = 106$

D) $\left(x - \frac{7}{2}\right)^2 + \left(y + \frac{5}{2}\right)^2 = 130$

Answer: A

86)

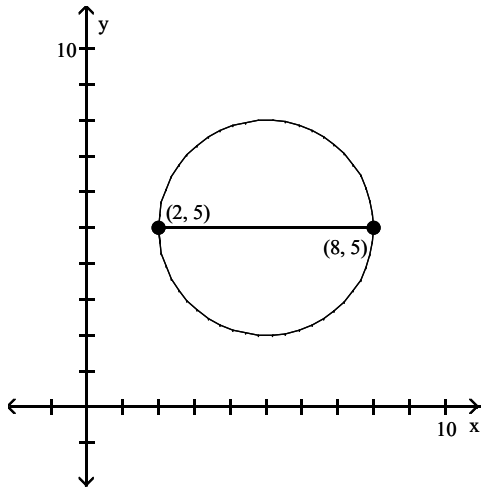

A) $(x - 5)^2 + (y - 5)^2 = 3$

B) $(x + 5)^2 + (y + 5)^2 = 9$

C) $(x + 5)^2 + (y + 5)^2 = 3$

D) $(x - 5)^2 + (y - 5)^2 = 9$

Answer: D

87)

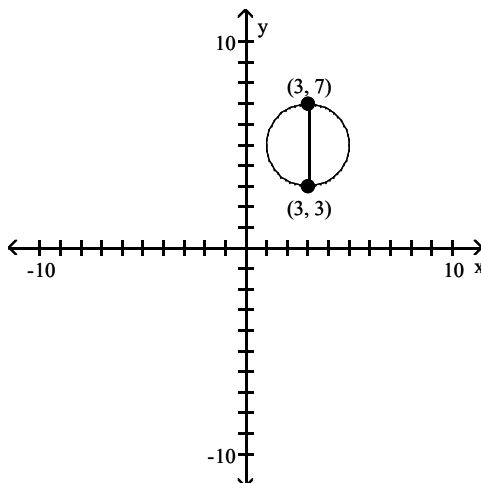

A) $(x + 3)^2 + (y + 5)^2 = 2$

B) $(x - 3)^2 + (y - 5)^2 = 4$

C) $(x - 3)^2 + (y - 5)^2 = 2$

D) $(x + 3)^2 + (y + 5)^2 = 4$

Answer: B

Solve the problem.

88) Suppose that receiving stations X, Y, and Z are located on a coordinate plane at the points (0, 7), (-12, 15), and (-8, -9) respectively. The epicenter of an earthquake is determined to be 5 units from X, 15 units from Y, and 13 units from Z. Where on the coordinate plane is the epicenter located?

A) at (-2, 3)

B) at (-4, 5)

C) at (-2, 2)

D) at (-3, 3)

Answer: D

89) The locations of three receiving stations and the distances to the epicenter of an earthquake are contained in the following three equations: $(x + 2)^2 + (y - 1)^2 = 16$, $(x + 7)^2 + (y + 3)^2 = 25$, $(x - 4)^2 + (y + 11)^2 = 100$. Determine the location of the epicenter.

A) at (-3, -1)

B) at (-1, -4)

C) at (-1, -3)

D) at (-2, -3)

Answer: D

90) Find the center-radius form of the equation of a circle with center (5, 7) and tangent to the x-axis.

A) $(x - 5)^2 + (y - 7)^2 = 25$

B) $(x + 5)^2 + (y + 7)^2 = 49$

C) $(x + 5)^2 + (y + 7)^2 = 25$

D) $(x - 5)^2 + (y - 7)^2 = 49$

Answer: D

91) Find the equation of a circle with center at (-4, 4), passing through the point (-1, 8). Write it in center-radius form.

A) $(x + 4)^2 + (y - 4)^2 = 25$

B) $(x - 4)^2 + (y + 4)^2 = 25$

C) $(x - 4)^2 + (y + 4)^2 = 5$

D) $(x + 4)^2 + (y - 4)^2 = 5$

Answer: A

92) Find all points (x, y) with $x = y$ that are 5 units from (9, 2).

A) (5, 5) and (6, 6)

B) (-5, -5) and (6, 6)

C) (-5, -5) and (-6, -6)

D) (5, 5) and (-6, -6)

Answer: A

93) Find all values of y such that the distance between (2, y) and (-10, 3) is 13.

A) -8, -2

B) -2, 8

C) -8, 2

D) 2, 8

Answer: B

94) A circle has a diameter with endpoints (-2, 1) and (22, 17). Find the coordinates of the center.

A) (46, 33)

B) (-14, -7)

C) (20, 18)

D) (10, 9)

Answer: D

95) A circle has a diameter with endpoints (-2, 1) and (22, 11). Find the radius.

A) 13

B) $\sqrt{13}$

C) $\sqrt{26}$

D) 26

Answer: A

96) Find the center-radius form of the equation of the circle having a diameter with endpoints (-5, 1) and (3, 7).

A) $(x - 3)^2 + (y + 7)^2 = 100$

B) $(x - 1)^2 + (y + 4)^2 = 5$

C) $(x + 3)^2 + (y - 7)^2 = 10$

D) $(x + 1)^2 + (y - 4)^2 = 25$

Answer: D

Decide whether the relation defines a function.

97) $\{(1, -4), (2, -3), (5, 6), (7, -7), (10, -6)\}$

A) Not a function

B) Function

Answer: B

98) $\{(-4, 1), (-3, -6), (3, -3), (3, 2)\}$

A) Not a function

B) Function

Answer: A

99) $\{(-8, 2), (-8, 8), (1, -9), (6, 3), (7, 5)\}$

A) Not a function

B) Function

Answer: A

100) $\{(-6, -4), (-1, 3), (1, 2), (5, -7)\}$

A) Function

B) Not a function

Answer: A

101)

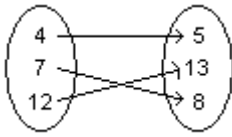

A) Function

B) Not a function

Answer: A

102)

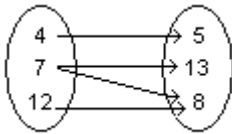

A) Not a function

B) Function

Answer: A

103)

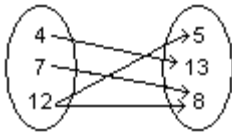

A) Not a function

B) Function

Answer: A

104) Student Test Score

Name	Test Score
Bob L.	81
Susan H.	83
Jim H.	76
Bruce B.	96

A) Not a function

B) Function

Answer: B

105) Student Test Score

Name	Test Score
Bob L.	79
Susan H.	83
Jim H.	79
Bruce B.	96

A) Not a function

B) Function

Answer: B

106) Annual New Telemarketing Companies

Year	Number
1995	37
1996	74
1997	149
1998	121
1999	261

A) Function

B) Not a function

Answer: A

107)

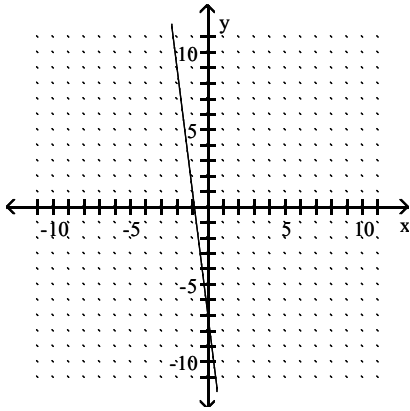

A) Function

B) Not a function

Answer: A

108)

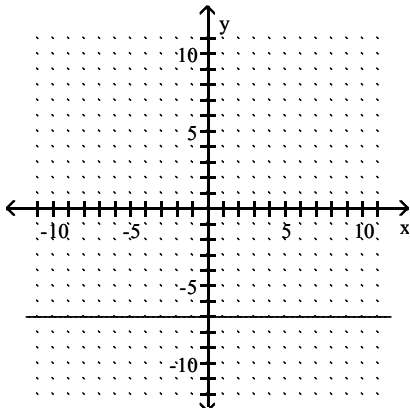

A) Function

B) Not a function

Answer: A

109)

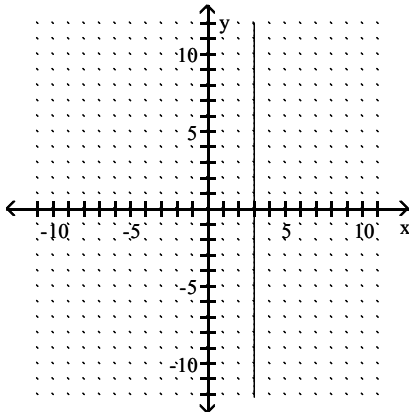

A) Not a function

B) Function

Answer: A

110)

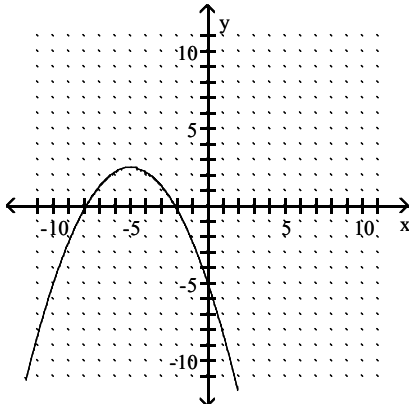

A) Function

B) Not a function

Answer: A

111)

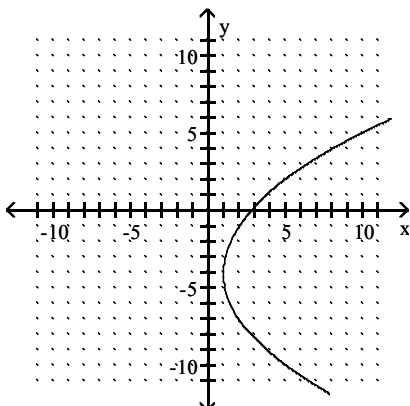

A) Not a function

B) Function

Answer: A

112)

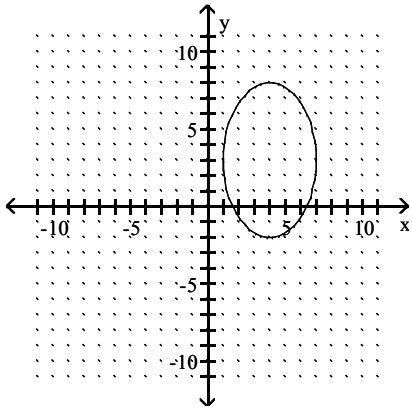

A) Not a function

B) Function

Answer: A

113)

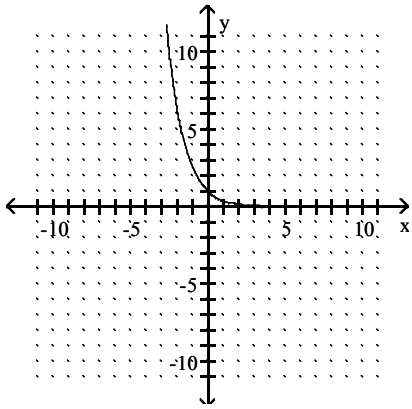

A) Not a function

B) Function

Answer: B

114)

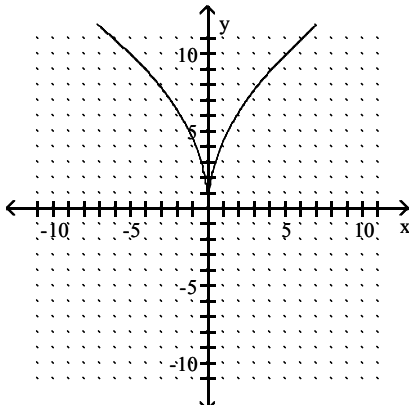

A) Not a function

B) Function

Answer: B

115)

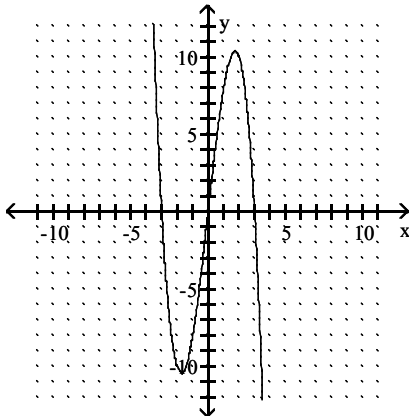

A) Not a function

B) Function

Answer: B

116)

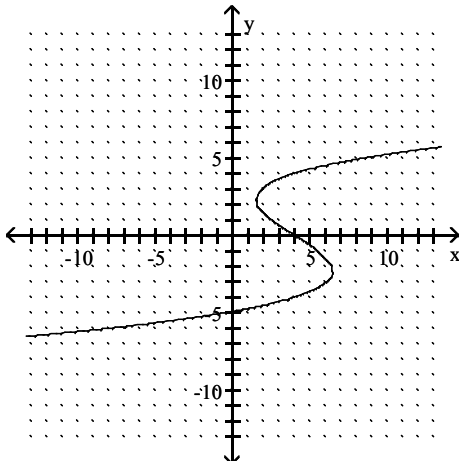

A) Not a function

B) Function

Answer: A

Give the domain and range of the relation.

117) $\{(2, 7), (-1, -9), (-6, -4), (6, 0)\}$

A) domain: $\{-9, -4, 0, 7\}$; range: $\{-6, -1, 2, 6\}$

C) domain: $\{-6, -1, 2, 6\}$; range: $\{-9, -4, 0, 7\}$

B) domain: $\{-9, -6, -4, -1\}$; range: $\{2, 6, 7\}$

D) domain: $\{2, 6, 7\}$; range: $\{-9, -6, -4, -1\}$

Answer: C

118) $\{(1, 9), (-2, -8), (-6, -5), (6, -8)\}$

A) domain: $\{-8, -5, 9\}$; range: $\{-6, -2, 1, 6\}$

C) domain: $\{-8, -6, -5, -2\}$; range: $\{1, 6, 9\}$

B) domain: $\{-6, -2, 1, 6\}$; range: $\{-8, -5, 9\}$

D) domain: $\{1, 6, 9\}$; range: $\{-8, -6, -5, -2\}$

Answer: B

119) $\{(3, 3), (-2, -2), (-7, -7), (4, 4)\}$

A) domain: $\{3, 4\}$; range: $\{-7, -2\}$

C) None of these

B) domain: $\{-7, -2\}$; range: $\{3, 4\}$

D) domain: $\{-7, -2, 3, 4\}$; range: $\{-7, -2, 3, 4\}$

Answer: D

120)

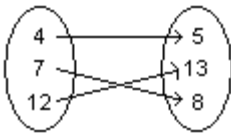

- A) domain: {4, 7, 12}; range: {5, 8, 13}
- C) None of these

- B) domain: {4, 5, 7}; range: {8, 12, 13}
- D) domain: {5, 8, 13}; range: {4, 7, 12}

Answer: A

121)

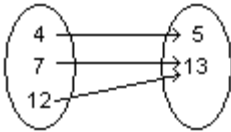

- A) domain: {5, 13}; range: {4, 7, 12}
- C) domain: {4, 5, 7}; range: {12, 13}

- B) domain: {4, 7, 12}; range: {5, 13}
- D) None of these

Answer: B

122)

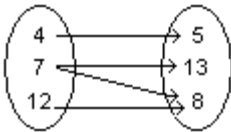

- A) None of these
- C) domain: {5, 8, 13}; range: {4, 7, 12}

- B) domain: {4, 12}; range: {5, 13}
- D) domain: {4, 7, 12}; range: {5, 8, 13}

Answer: D

123)

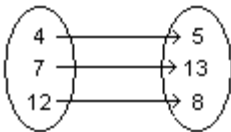

- A) domain: {4, 7, 12}; range: {5, 8, 13}
- C) None of these

- B) domain: {4, 8, 12}; range: {5, 7, 13}
- D) domain: {5, 8, 13}; range: {4, 7, 12}

Answer: A

124)

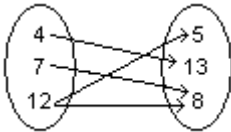

- A) domain: {4, 8, 12}; range: {5, 7, 13}
- C) domain: {5, 8, 13}; range: {4, 7, 12}

- B) domain: {4, 7, 12}; range: {5, 8, 13}
- D) None of these

Answer: C

125) Annual New Telemarketing Companies

Year	Number
1995	56
1996	112
1997	187
1998	178
1999	318

- A) None of these
- B) domain: {Year}; range: {Number}
- C) domain: {56, 112, 178, 187, 318}; range: {1995, 1996, 1997, 1998, 1999}
- D) domain: {1995, 1996, 1997, 1998, 1999}; range: {56, 112, 178, 187, 318}

Answer: D

126) Annual New Telemarketing Companies

Year	Number
1993	52
1994	102
1995	187
1996	170
1997	218

- A) domain: {Year}; range: {Number}
- B) domain: {52, 102, 170, 187, 218}; range: {1993, 1994, 1995, 1996, 1997}
- C) domain: {1993, 1994, 1995, 1996, 1997}; range: {52, 102, 170, 187, 218}
- D) None of these

Answer: C

127)

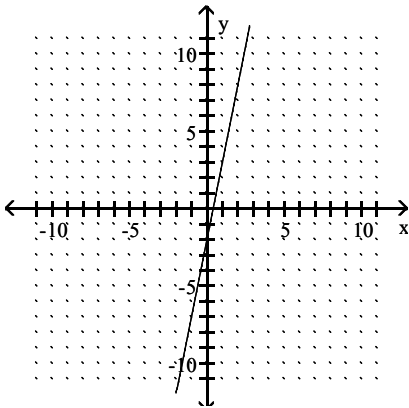

- A) domain: $(-\infty, 0] \cup [0, \infty)$; range: $(-\infty, -2] \cup [-2, \infty)$
- B) domain: $(-\infty, 0) \cup (0, \infty)$; range: $(-\infty, -2) \cup (-2, \infty)$
- C) domain: $(-\infty, \infty)$; range: $(-\infty, \infty)$
- D) domain: $(-\infty, -2) \cup (-2, \infty)$; range: $(-\infty, 0) \cup (0, \infty)$

Answer: C

128)

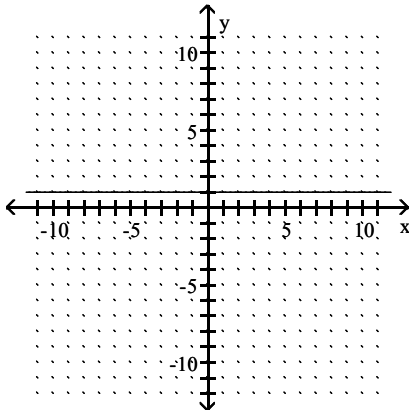

- A) domain: $(-\infty, \infty)$; range: $\{1\}$
- C) domain: $(-\infty, \infty)$; range: $(-\infty, \infty)$

- B) domain: $(-\infty, \infty)$; range: $(-\infty, 1) \cup (1, \infty)$
- D) domain: $\{1\}$; range: $(-\infty, \infty)$

Answer: A

129)

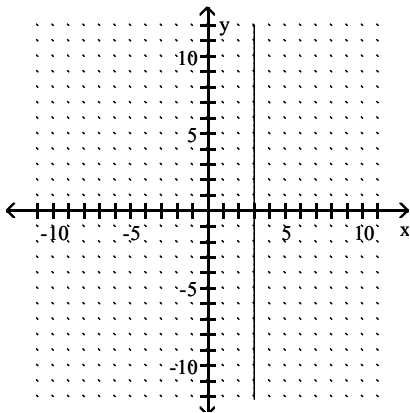

- A) domain: $\{3\}$; range: $(-\infty, \infty)$
- C) domain: $(-\infty, \infty)$; range: $(-\infty, \infty)$

- B) domain: $(-\infty, \infty)$; range: $\{3\}$
- D) domain: $(-\infty, 3) \cup (3, \infty)$; range: $(-\infty, \infty)$

Answer: A

130)

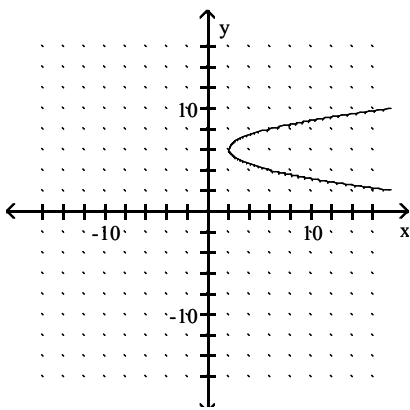

- A) domain: $[2, \infty)$; range: $(-\infty, \infty)$
- C) domain: $(-\infty, \infty)$; range: $(-\infty, \infty)$

- B) domain: $(-\infty, \infty)$; range: $[2, \infty)$
- D) domain: $(2, \infty)$; range: $(6, \infty)$

Answer: A

131)

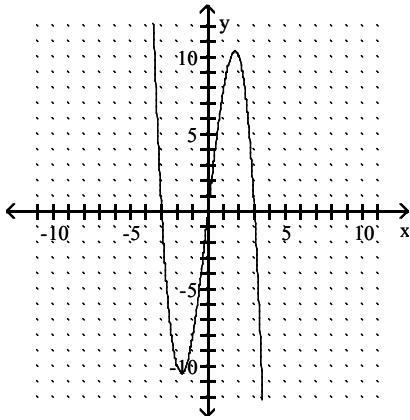

- A) range: $(-\infty, -3) \cup (-3, 0) \cup (0, 3) \cup (3, \infty)$; domain: $(-\infty, -10) \cup (-10, 0) \cup (0, 10) \cup (10, \infty)$
 B) range: $(-\infty, \infty)$; domain: $(-\infty, \infty)$
 C) range: $(-3, 0) \cup (0, 3)$; domain: $(-10, 0) \cup (0, 10)$
 D) range: $(-3, 3)$; domain: $(-10, 10)$

Answer: B

132)

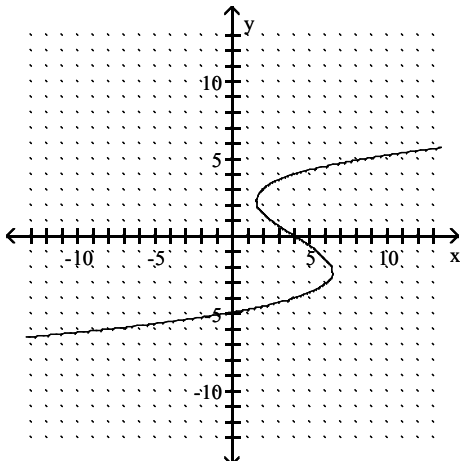

- A) range: $(-\infty, \infty)$; domain: $(-\infty, \infty)$
 B) range: $(-\infty, 0) \cup (0, 4) \cup (4, \infty)$; domain: $(-\infty, -5) \cup (-5, 0) \cup (0, \infty)$
 C) range: $(-\infty, 4) \cup (4, \infty)$; domain: $(-\infty, -5) \cup (-5, \infty)$
 D) None of these

Answer: A

133)

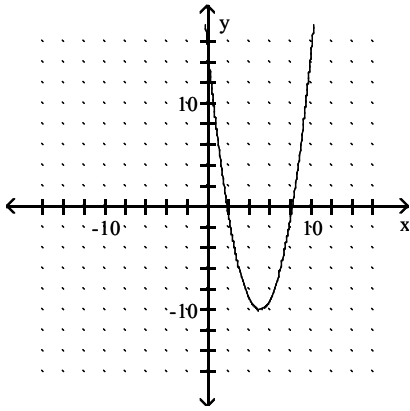

A) domain: $(-\infty, \infty)$; range: $[-10, \infty)$

C) domain: $(0, \infty)$; range: $[35, \infty)$

B) domain: $(-\infty, 0)$; range: $(-\infty, 0)$

D) domain: $(-\infty, 0) \cup (0, \infty)$; range: $(-\infty, 0) \cup (0, \infty)$

Answer: A

134)

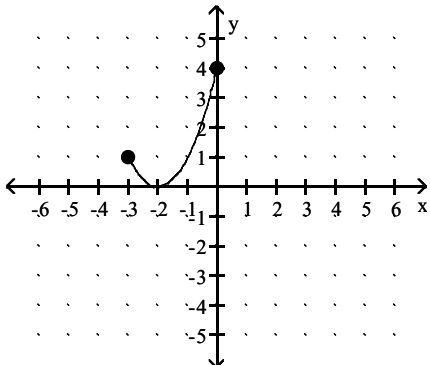

A) domain: $[-3, 0]$; range: $[-0, 4]$

C) domain: $[-0, 4]$; range: $[-3, 0]$

B) domain: $(-\infty, 4]$; range: $[0, 3]$

D) domain: $[0, 3]$; range: $(-\infty, 4]$

Answer: A

135)

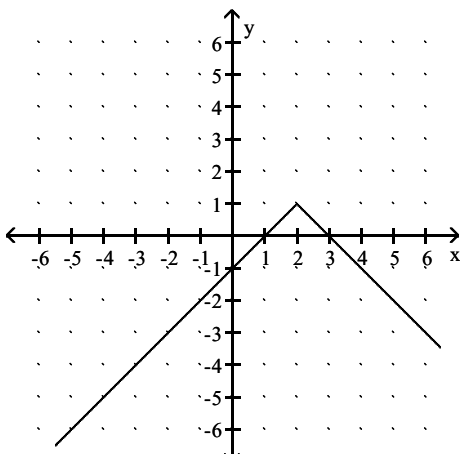

A) domain: $(-\infty, \infty)$; range: $(-\infty, 1]$

C) domain: $(-\infty, \infty)$; range: $(-\infty, \infty)$

B) domain: $(-\infty, 2]$; range: $(-\infty, 1]$

D) domain: $(-\infty, 2) \cup (2, \infty)$; range: $(-\infty, 1) \cup (1, \infty)$

Answer: A

136)

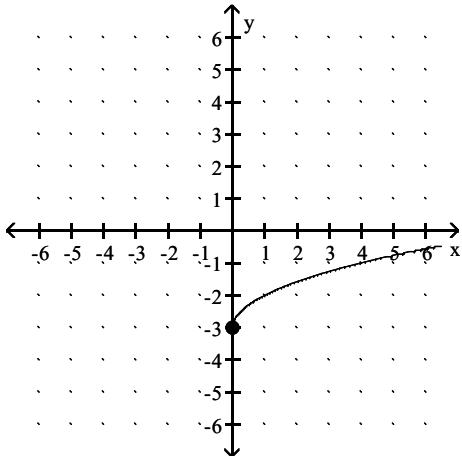

- A) domain: $(-\infty, \infty)$; range: $[-3, \infty)$
- C) domain: $[0, \infty)$; range: $[0, \infty)$

- B) domain: $[0, \infty)$; range: $[-3, \infty)$
- D) domain: $[0, \infty)$; range: $(-\infty, \infty)$

Answer: B

Decide whether the relation defines a function.

137) $7x = 14 - 5y$

- A) Function

- B) Not a function

Answer: A

138) $y = 7x - 3$

- A) Function

- B) Not a function

Answer: A

139) $y = x^3$

- A) Not a function

- B) Function

Answer: B

140) $y^2 = 2x$

- A) Not a function

- B) Function

Answer: A

141) $y = \sqrt{3x - 6}$

- A) Function

- B) Not a function

Answer: A

142) $3x + 5y > -5$

- A) Not a function

- B) Function

Answer: A

143) $x = y^4$

- A) Function

- B) Not a function

Answer: B

144) $y = x^6$

A) Function

Answer: A

B) Not a function

145) $xy = -3$

A) Function

Answer: A

B) Not a function

146) $y = \frac{1}{x-5}$

A) Function

Answer: A

B) Not a function

Give the domain and range of the relation.

147) $y = x^2 + 1$

A) domain: $(-\infty, \infty)$; range: $[1, \infty)$

C) domain: $(1, \infty)$; range: $(-\infty, \infty)$

Answer: A

B) domain: $(-\infty, \infty)$; range: $(-1, \infty)$

D) domain: $(-1, \infty)$; range: $(-\infty, \infty)$

148) $y = (x + 1)^2 - 1$

A) domain: $(1, \infty)$; range: $(-\infty, \infty)$

C) domain: $(-\infty, \infty)$; range: $[-1, \infty)$

Answer: C

B) domain: $(-\infty, -1)$; range: $(-\infty, \infty)$

D) domain: $(-\infty, \infty)$; range: $(-\infty, -1)$

149) $y = 6x - 2$

A) domain: $(-\infty, \infty)$; range: $[-2, \infty)$

C) domain: $(-\infty, \infty)$; range: $(-\infty, \infty)$

Answer: C

B) domain: $[0, \infty)$; range: $(-\infty, \infty)$

D) domain: $(-\infty, \infty)$; range: $[0, \infty)$

150) $y = 4x^9$

A) domain: $(-\infty, \infty)$; range: $[4, \infty)$

C) domain: $(-\infty, \infty)$; range: $[0, \infty)$

Answer: D

B) domain: $(-\infty, \infty)$; range: $[-4, \infty)$

D) domain: $(-\infty, \infty)$; range: $(-\infty, \infty)$

151) $x = y^2$

A) domain: $[0, \infty)$; range: $[0, \infty)$

C) domain: $(-\infty, \infty)$; range: $[0, \infty)$

Answer: D

B) domain: $(-\infty, \infty)$; range: $(-\infty, \infty)$

D) domain: $[0, \infty)$; range: $(-\infty, \infty)$

152) $xy = -7$

A) domain: $[0, \infty)$; range: $(-\infty, \infty)$

C) domain: $(-\infty, 0) \cup (0, \infty)$; range: $(-\infty, 0) \cup (0, \infty)$

Answer: C

B) domain: $(-\infty, 0) \cup (0, \infty)$; range: $[0, \infty)$

D) domain: $(-\infty, \infty)$; range: $(-\infty, \infty)$

153) $y = \sqrt{4 + x}$

A) domain: $[-4, \infty)$; range: $[0, \infty)$

C) domain: $(-\infty, \infty)$; range: $[-4, \infty)$

Answer: A

B) domain: $[0, \infty)$; range: $(-\infty, \infty)$

D) domain: $(-\infty, \infty)$; range: $(-\infty, \infty)$

154) $y = \sqrt{2x - 6}$

A) domain: $[3, \infty)$; range: $(-\infty, \infty)$

C) domain: $(3, \infty)$; range: $[0, \infty)$

Answer: D

B) domain: $(-\infty, \infty)$; range: $[3, \infty)$

D) domain: $[3, \infty)$; range: $[0, \infty)$

155) $y = \frac{14}{4 - x}$

A) domain: $(-\infty, 4) \cup (4, \infty)$; range: $(-\infty, 0) \cup (0, \infty)$

C) domain: $(-\infty, 4) \cup (4, \infty)$; range: $(-\infty, \infty)$

Answer: A

B) domain: $(-\infty, \infty)$; range: $(-\infty, 0) \cup (0, \infty)$

D) domain: $(-\infty, \infty)$; range: $(-\infty, \infty)$

156) $y = \frac{-2}{x - 3}$

A) domain: $(-\infty, -3) \cup (3, \infty)$; range: $(-\infty, \infty)$

B) domain: $(-\infty, 3) \cup (3, \infty)$; range: $(-\infty, 0) \cup (0, \infty)$

C) domain: $(-\infty, 3) \cup (3, \infty)$; range: $(-\infty, \infty)$

D) domain: $(-\infty, -3) \cup (-3, \infty)$; range: $(-\infty, 0) \cup (0, \infty)$

Answer: B

Evaluate the function.

157) Find $f(5)$ when $f(x) = 6x - 3$

A) 33

B) 15

C) 27

D) 3

Answer: C

158) Find $f(3)$ when $f(x) = x^2 - 2x - 5$

A) 20

B) -2

C) 10

D) 8

Answer: B

159) Find $f(0)$ when $f(x) = x^2 - 2x - 3$

A) 3

B) -3

C) 0

D) 9

Answer: B

160) Find $f(-3)$ when $f(x) = 3x^2 + 5x - 3$

A) 9

B) 15

C) -9

D) 39

Answer: A

161) Find $f\left(\frac{1}{2}\right)$ when $f(x) = 3x^2 + 4x - 1$

A) $\frac{3}{2}$

B) $\frac{7}{4}$

C) $-\frac{7}{4}$

D) $-\frac{3}{2}$

Answer: B

162) Find $g(a - 1)$ when $g(x) = \frac{1}{2}x + 3$.

A) $\frac{1}{2}a + 3$

B) $\frac{a + 5}{2}$

C) $\frac{1}{2}a - 2$

D) $\frac{a - 5}{2}$

Answer: B

163) Find $g(a - 1)$ when $g(x) = 2x + 5$.

A) $2a + 5$

B) $\frac{1}{2}a + 5$

C) $2a + 3$

D) $2a + 1$

Answer: C

164) Find $f(k)$ when $f(x) = 3x^2 + 4x + 5$

A) $3k^2 + 16k + 5$

B) $3k^2 + 4k + 25$

C) $3k^2 + 4k + 5$

D) $9k^2 + 16k + 25$

Answer: C

165) Find $f(-x)$ when $f(x) = -3x^2 - 2x - 5$

A) $-3x^2 + 2x + 5$

B) $-3x^2 + 2x - 5$

C) $3x^2 + 2x + 5$

D) $3x^2 + 2x - 5$

Answer: B

166) Find $f(k - 1)$ when $f(x) = 5x^2 + 4x + 2$

A) $5k^2 + 14k + 11$

B) $-6k^2 + 5k + 3$

C) $5k^2 - 6k + 3$

D) $5k^2 - 6k + 11$

Answer: C

167) Find $f(-2)$ if $f = \{(-2, 3), (3, 0), (0, 5), (5, -2)\}$

A) $(3, 5)$

B) 5

C) 3

D) None of these

Answer: C

168) Find $f(4)$

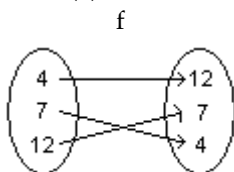

A) None of these

B) 7

C) 12

D) $(12, 7)$

Answer: C

The graph of $y = f(x)$ is given. Use the graph to find the function value.

169)

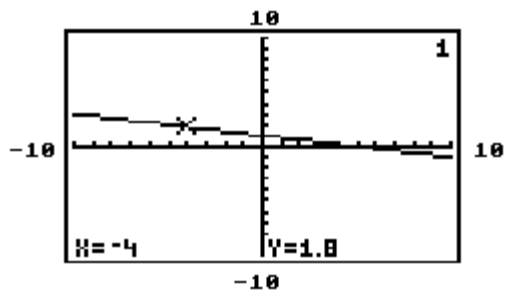

Find $f(-4)$.

A) None of these

B) -4

C) 1.8

D) 1

Answer: C

170)

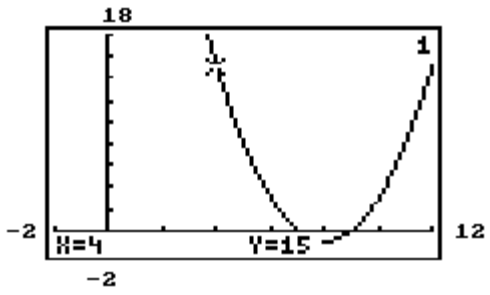

Find $f(4)$.

A) None of these

B) 15

C) -1

D) 4

Answer: B

171)

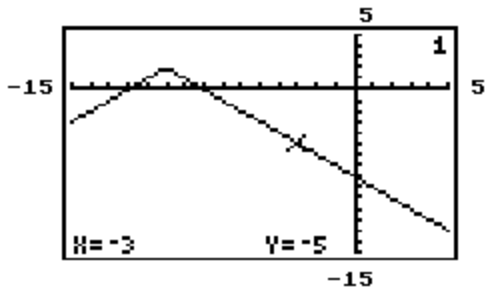

Find $f(-3)$.

A) None of these

B) 2

C) -5

D) -3

Answer: C

172) Find $f(-5)$.

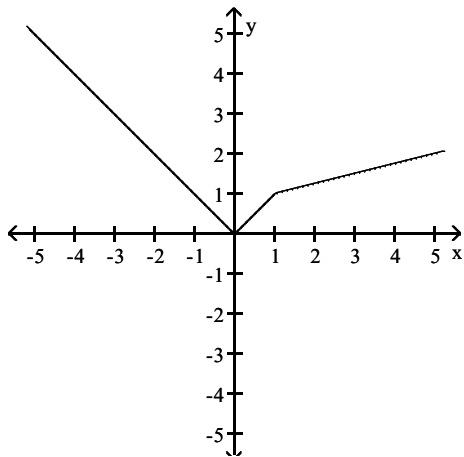

A) 2

B) -5

C) 17

D) 5

Answer: D

173) Find $f(4)$.

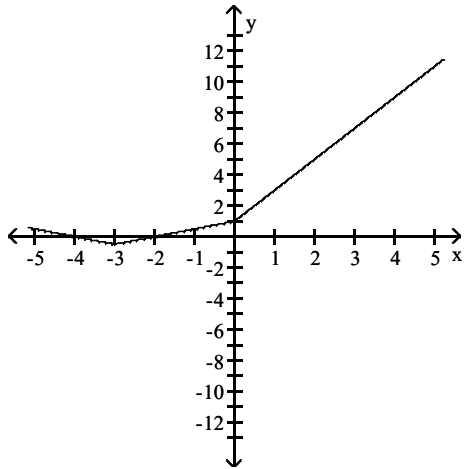

A) 7

B) 9

C) 1.5

D) -9

Answer: B

174) Find $f(-12)$.

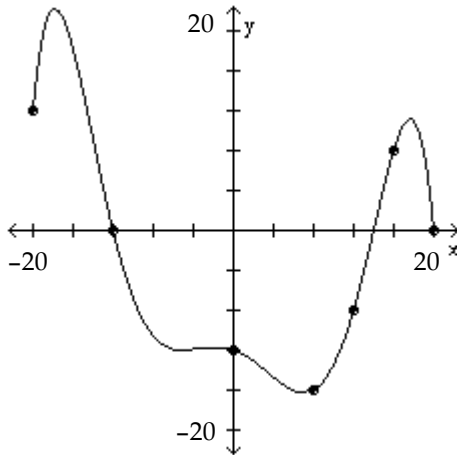

A) -8

B) 20

C) 0

D) -12

Answer: C

An equation that defines y as a function of x is given. Rewrite the equation using function notation $f(x)$.

175) $x - 2y = 14$

A) $f(x) = \frac{1}{2}x - 7$

B) $f(x) = -\frac{1}{2}x + 7$

C) $f(x) = -x + 7$

D) $f(x) = \frac{1}{2}x - 14$

Answer: A

176) $x + 3y = 4$

A) $f(x) = -\frac{1}{3}x + \frac{4}{3}$

B) $f(x) = -x + \frac{4}{3}$

C) $f(x) = \frac{1}{3}x + \frac{4}{3}$

D) $f(x) = 3x - 4$

Answer: A

177) $y - 3x^2 = 8 - x$

A) $f(x) = -3x^2 + x - 8$

B) $f(x) = -3x^2 - x + 8$

C) $f(x) = 3x^2 - x + 8$

D) $f(x) = 3x^2 + x + 8$

Answer: C

178) $8x + 5y = 7$

A) $f(x) = \frac{8}{5}x + \frac{7}{5}$

B) $f(x) = -\frac{8}{5}x + \frac{7}{5}$

C) $f(x) = \frac{8}{5}x - \frac{7}{5}$

D) $f(x) = 8x - 7$

Answer: B

179) $9x - 3y = 7$

A) $f(x) = 3x + \frac{7}{3}$

B) $f(x) = 9x - 7$

C) $f(x) = \frac{1}{3}x + \frac{7}{9}$

D) $f(x) = 3x - \frac{7}{3}$

Answer: D

Determine the largest open intervals of the domain over which the function is increasing, decreasing, and constant.

180)

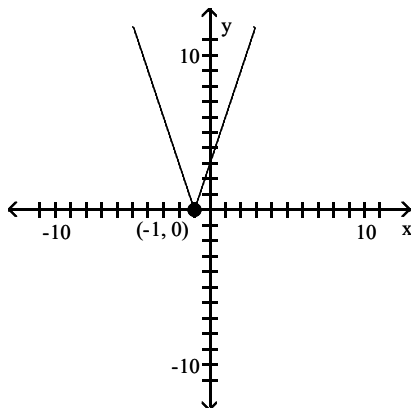

A) Increasing $(1, \infty)$; Decreasing $(-\infty, 1)$

C) Increasing $(-\infty, -1)$; Decreasing $(-1, \infty)$

B) Increasing $(-\infty, 1)$; Decreasing $(1, \infty)$

D) Increasing $(-1, \infty)$; Decreasing $(-\infty, -1)$

Answer: D

181)

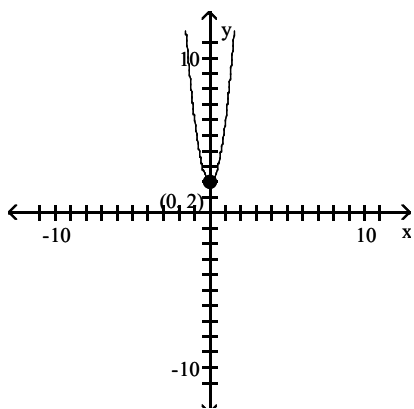

A) Increasing $(-\infty, 0)$; Decreasing $(0, \infty)$

C) Increasing $(0, \infty)$; Decreasing $(-\infty, 0)$

B) Increasing $(-\infty, 0)$; Decreasing $(-\infty, 0)$

D) Increasing $(-\infty, 0)$; Decreasing $(0, -\infty)$

Answer: C

182)

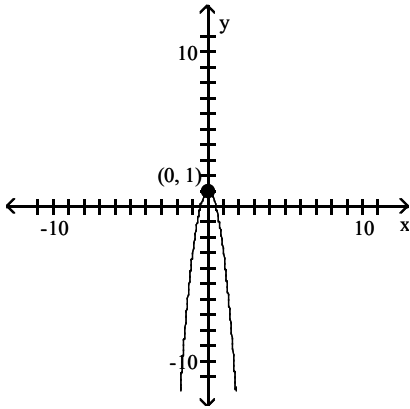

- A) Increasing $(-\infty, 0)$; Decreasing $(0, \infty)$
 C) Increasing $(-\infty, 0)$; Decreasing $(0, -\infty)$

- B) Increasing $(0, \infty)$; Decreasing $(-\infty, 0)$
 D) Increasing $(-\infty, 0)$; Decreasing $(-\infty, 0)$

Answer: A

183)

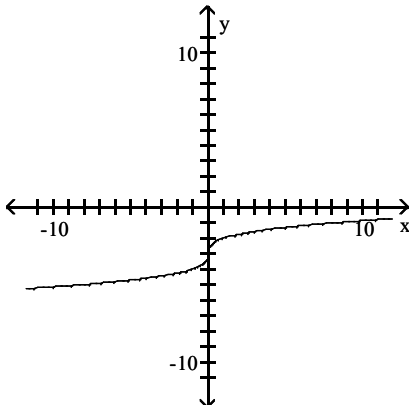

- A) Increasing $(-\infty, 0)$; Decreasing $(0, \infty)$
 C) Increasing never; Decreasing for all reals

- B) Increasing $(0, \infty)$; Decreasing $(-\infty, 0)$
 D) Increasing for all reals; Decreasing never

Answer: D

184)

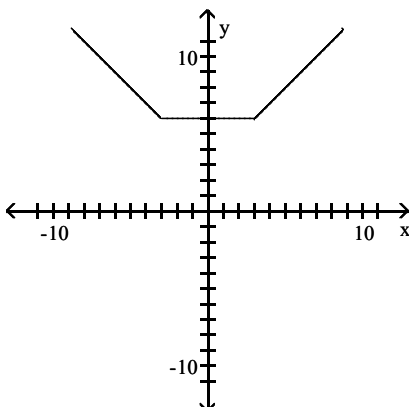

- A) Increasing $(-\infty, 3)$; Decreasing $(-3, \infty)$; Constant $(-3, 3)$
 B) Increasing $(-\infty, 3)$; Decreasing $(-\infty, -3)$; Constant $(-3, 3)$
 C) Increasing $(3, \infty)$; Decreasing $(-3, \infty)$; Constant $(-3, 3)$
 D) Increasing $(3, \infty)$; Decreasing $(-\infty, -3)$; Constant $(-3, 3)$

Answer: D

185)

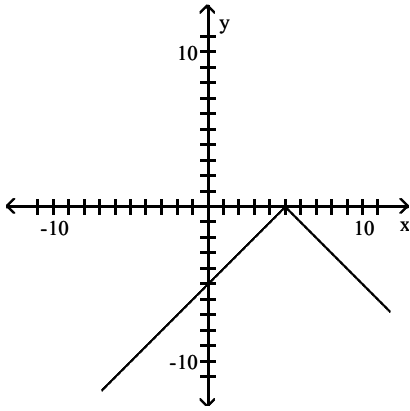

- A) Increasing $(5, \infty)$; Decreasing $(-\infty, 5)$
 C) Increasing $(5, \infty)$; Decreasing $(5, \infty)$

- B) Increasing $(-\infty, 5)$; Decreasing $(-\infty, 5)$
 D) Increasing $(-\infty, 5)$; Decreasing $(5, \infty)$

Answer: D

186)

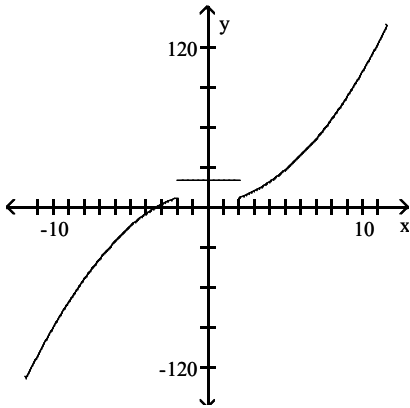

- A) Increasing $(-\infty, -2) \cup (2, \infty)$; Decreasing never
 C) Increasing $(2, \infty)$; Decreasing $(-\infty, -2)$

- B) Increasing never; Decreasing $(-\infty, -2) \cup (2, \infty)$
 D) Increasing $(-2, 2)$; Decreasing $(-\infty, -2) \cup (2, \infty)$

Answer: A

Use the graph to solve the problem.

187) The height h in feet of a projectile thrown upward from the roof of a building after time t seconds is shown in the graph below. How high will the projectile be after 0.9 s?

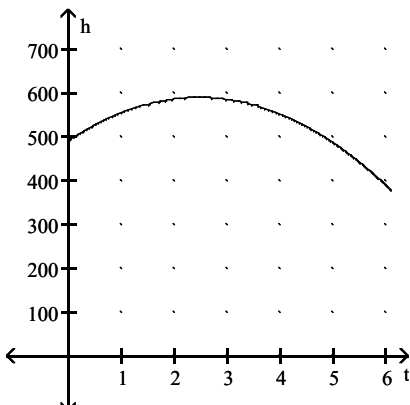

- A) 450 ft B) 500 ft C) 550 ft D) 600 ft

Answer: C

188) The surface area a of a cylinder is shown in the graph below. What is the radius r if the surface area is 25 m^2 ?

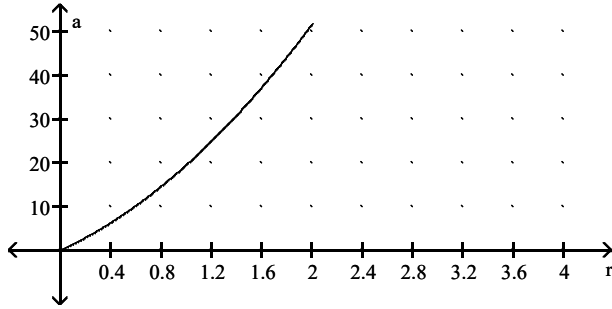

A) 1.0 m

B) 1.2 m

C) 1.4 m

D) 1.6 m

Answer: B

189) The graph shows the relationship between current I and resistance R if the voltage is fixed. Find the current if the resistance is 2.5Ω .

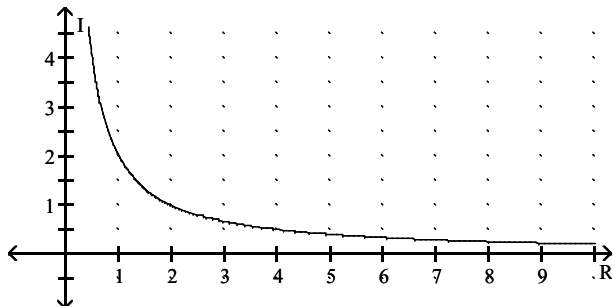

A) 0.6 A

B) 1.0 A

C) 0.8 A

D) 1.2 A

Answer: C

190) The graph shows the relationship between the area A of a rectangle and the length L , if the width is fixed. Find the area if the length is 5 cm.

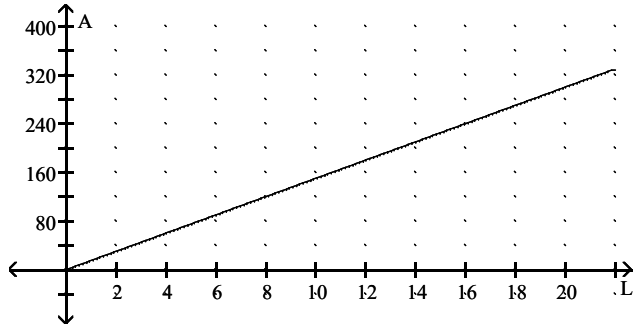

A) 75 cm^2

B) 30 cm^2

C) 45 cm^2

D) 15 cm^2

Answer: A

The line graph shows the recorded hourly temperatures in degrees Fahrenheit at an airport.

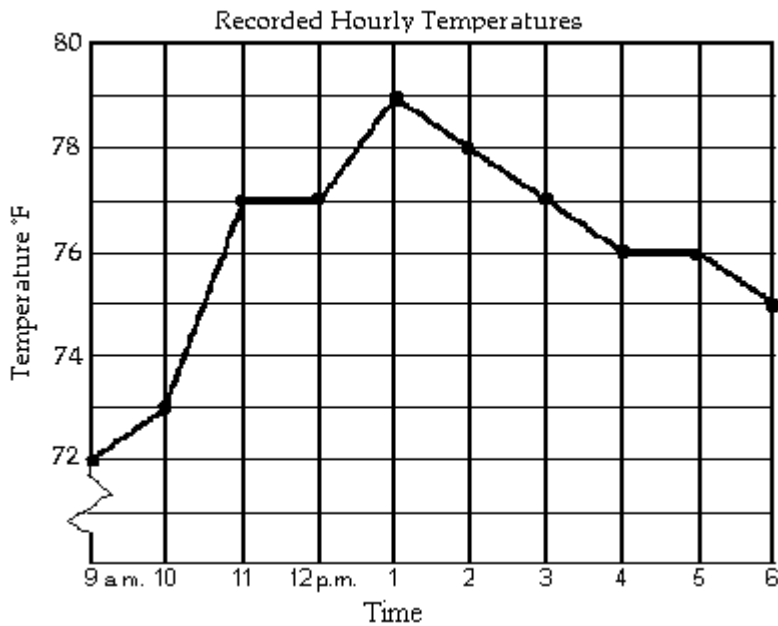

191) At what time was the temperature the highest?

- A) 5 p.m. B) 2 p.m. C) 11 a.m. D) 1 p.m.

Answer: D

192) At what time was the temperature its lowest?

- A) 4 p.m. B) 1 p.m. C) 6 p.m. D) 9 a.m.

Answer: D

193) What temperature was recorded at 4 p.m.?

- A) 74 ° F B) 76 ° F C) 78 ° F D) 77 ° F

Answer: B

194) During which hour did the temperature increase the most?

- A) 12 p.m. to 1 p.m. B) 10 a.m. to 11 a.m. C) 9 a.m. to 10 a.m. D) 1 p.m. to 2 p.m.

Answer: B

195) At what time was the temperature 79°?

- A) 12 p.m. B) 4 p.m. C) 1 p.m. D) 3 p.m.

Answer: C

196) During which two hour period did the temperature increase the most?

- A) 12 p.m. to 2 p.m. B) 10 a.m. to 11 a.m. C) 9 a.m. to 11 a.m. D) 10 a.m. to 12 p.m.

Answer: C

197) At what times was the temperature higher than 77°F?

- A) from 12 p.m. until 1 p.m. B) from 12 p.m. until 3 p.m.
 C) from 11 a.m. until 3 p.m. D) after 12 p.m.

Answer: B

- 198) At what times was the temperature below 77°F?
 A) from 12 p.m. until 3 p.m.
 B) after 3 p.m.
 C) from 9 a.m. until 11 a.m. and from 3 p.m. until 6 p.m.
 D) from 9 a.m. until 12 p.m. and from 3 p.m. until 6 p.m.

Answer: C

Match the description with the correct symbolic expression.

- 199) a linear function whose graph has a slope of 8
 A) $8x - 8y = 6$ B) $x = 8$ C) $f(x) = -10x + 8$ D) $y = 8x + 6$
 Answer: D
- 200) a linear function whose graph has y-intercept -8
 A) $x = -8$ B) $y = -8x + 11$ C) $f(x) = -7x - 8$ D) $-8x + 13y = 11$
 Answer: C
- 201) a vertical line
 A) $x = 2$ B) $f(x) = -4x + 2$ C) $2x - 4y = 7$ D) $y = 2x + 7$
 Answer: A
- 202) a constant function
 A) $f(x) = -4$ B) $-5x + 9y = 13$ C) $x = -5$ D) $y = -5x + 13$
 Answer: A
- 203) a linear equation whose graph has x-intercept -5 and y-intercept 19
 A) $y = 19x + 95$ B) $-19x + 5y = 95$ C) $x = 19$ D) $f(x) = -5$
 Answer: B
- 204) a linear function whose graph passes through the origin
 A) $x = 4$ B) $y = -4x$ C) $f(x) = 4$ D) $8x - 7y = 8$
 Answer: B
- 205) a line with a negative slope
 A) $f(x) = 2x - 4$ B) $x = -4$ C) $2x + 9y = -5$ D) $y = -5$
 Answer: C
- 206) a function that is not linear
 A) $f(x) = 6x + 4$ B) $f(x) = -2$ C) $f(x) = -9x + 6$ D) $f(x) = x^4 - 9$
 Answer: D
- 207) a line with a positive slope
 A) $y = -1x + 12$ B) $y = x^{12}$ C) $x = -1$ D) $-14x + 9y = 12$
 Answer: D
- 208) a horizontal line
 A) $f(x) = 2$ B) $y = -7x + 16$ C) $16x + 2y = -4$ D) $x = -7$
 Answer: A

Graph the linear function and give the domain and the range. If the function is a constant function, identify it as such.

209) $f(x) = 6x + 3$

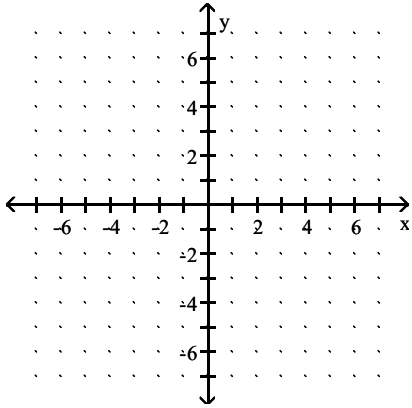

A) $D = (-\infty, \infty)$, $R = (-\infty, \infty)$

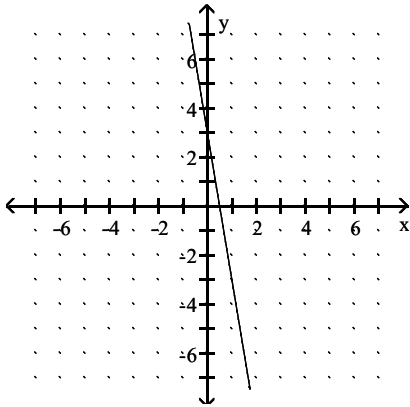

C) $D = (-\infty, \infty)$, $R = (-\infty, \infty)$

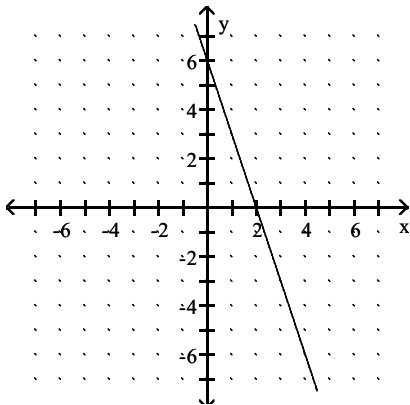

B) $D = (-\infty, \infty)$, $R = (-\infty, \infty)$

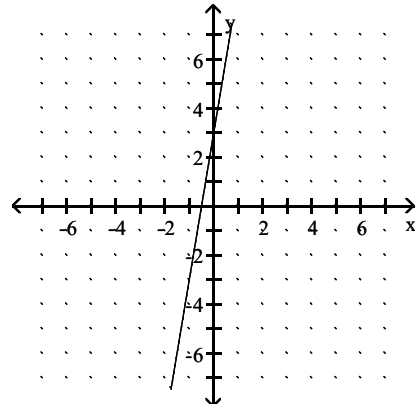

D) $D = (-\infty, \infty)$, $R = (-\infty, \infty)$

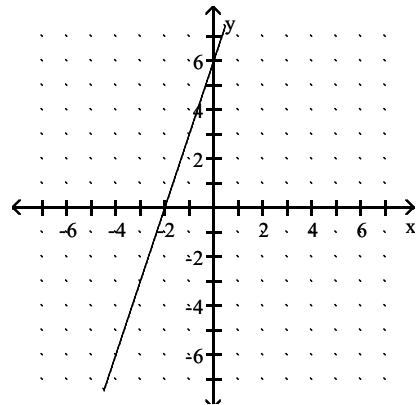

Answer: B

210) $g(x) = x + 2$

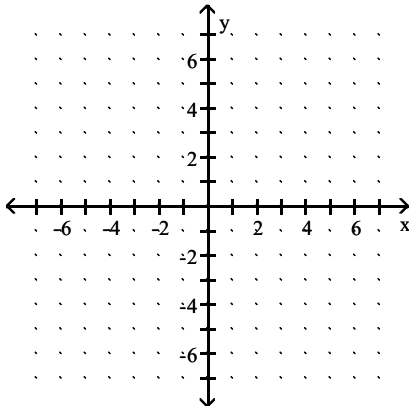

A) $D = (-\infty, \infty), R = (-\infty, \infty)$

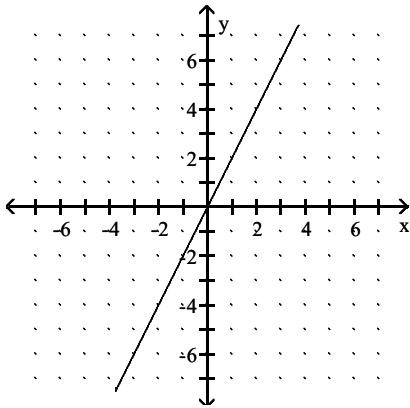

C) $D = (-\infty, \infty), R = (-\infty, \infty)$

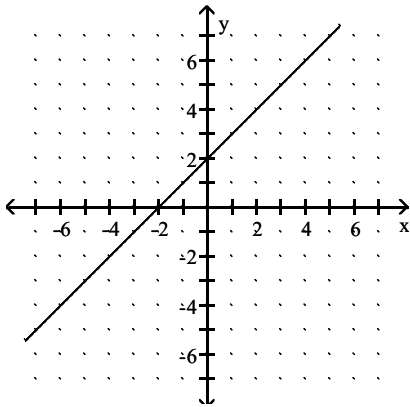

Answer: C

B) $D = (-\infty, \infty), R = (-\infty, \infty)$

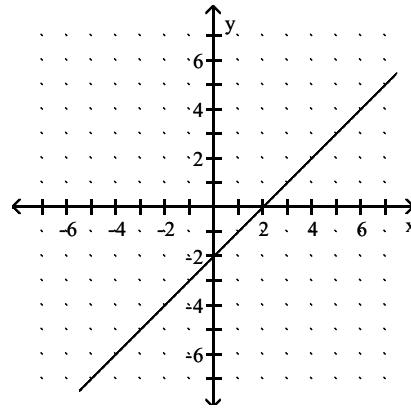

D) $D = (-\infty, \infty), R = (-\infty, \infty)$

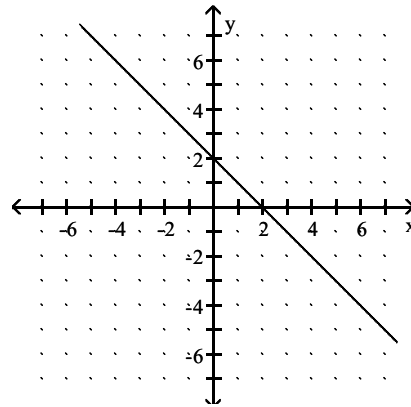

211) $h(x) = -4x$

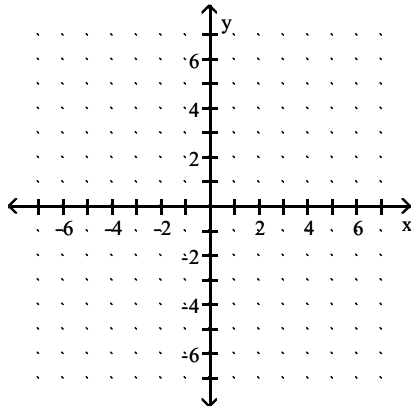

A) $D = (-\infty, \infty), R = (-\infty, \infty)$

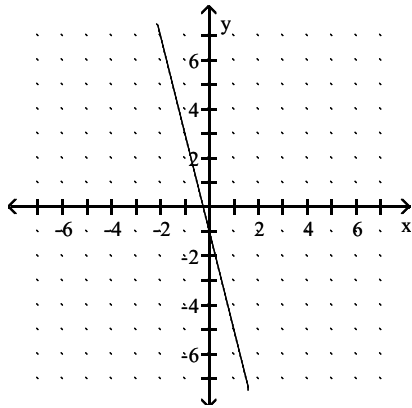

C) $D = (-\infty, \infty), R = (-\infty, \infty)$

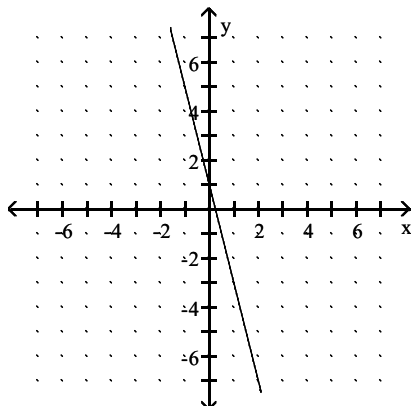

B) $D = (-\infty, \infty), R = (-\infty, \infty)$

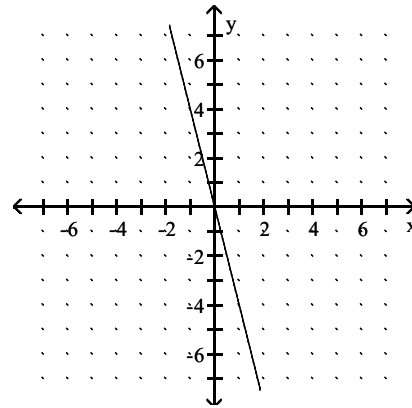

D) $D = (-\infty, \infty), R = (-\infty, \infty)$

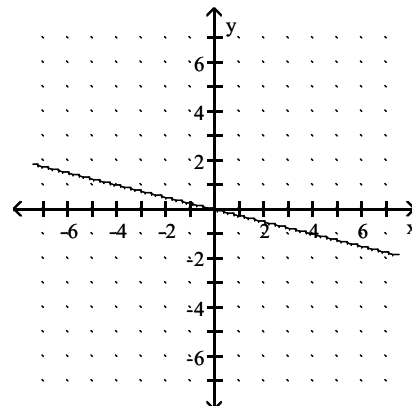

Answer: B

212) $f(x) = \frac{1}{4}x - 3$

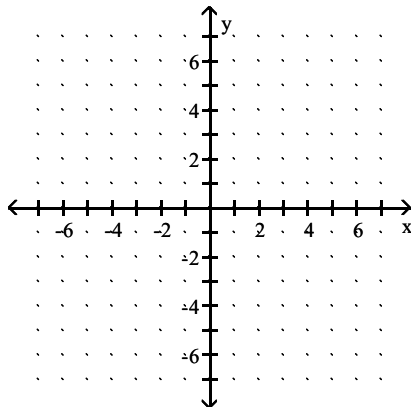

A) $D = (-\infty, \infty)$, $R = (-\infty, \infty)$

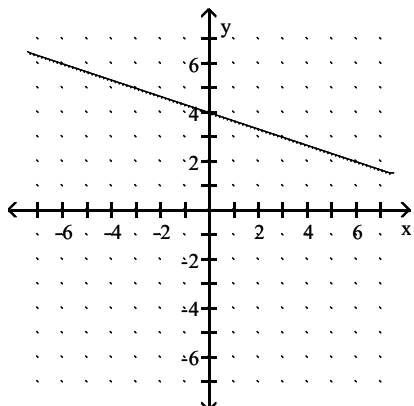

C) $D = (-\infty, \infty)$, $R = (-\infty, \infty)$

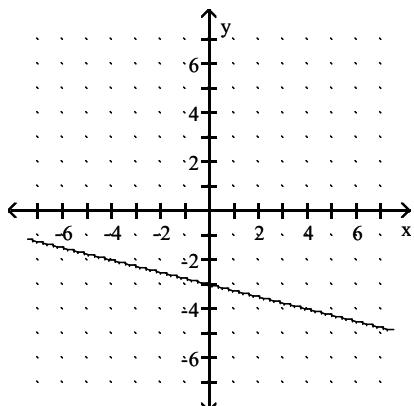

B) $D = (-\infty, \infty)$, $R = (-\infty, \infty)$

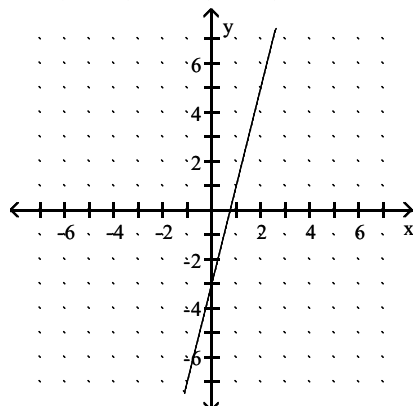

D) $D = (-\infty, \infty)$, $R = (-\infty, \infty)$

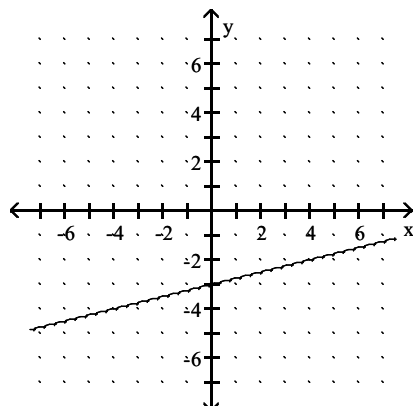

Answer: D

213) $f(x) = \frac{1}{2}x$

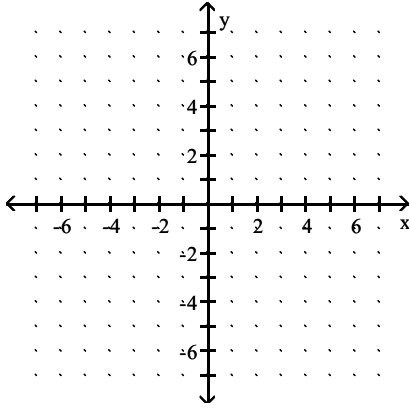

A) $D = (-\infty, \infty), R = (-\infty, \infty)$

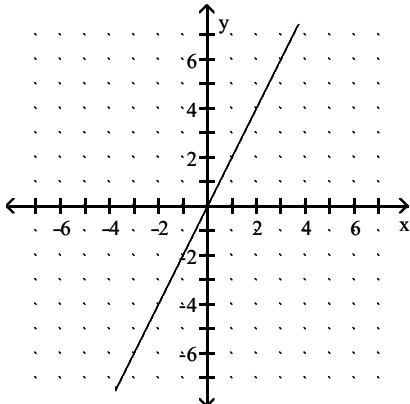

C) $D = (-\infty, \infty), R = (-\infty, \infty)$

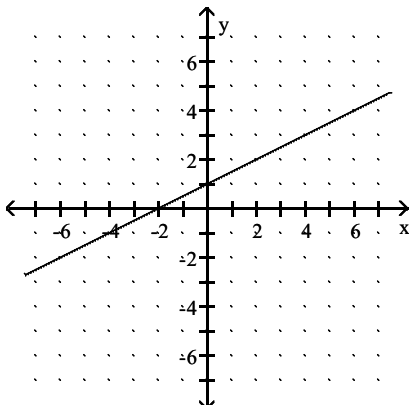

B) $D = (-\infty, \infty), R = (-\infty, \infty)$

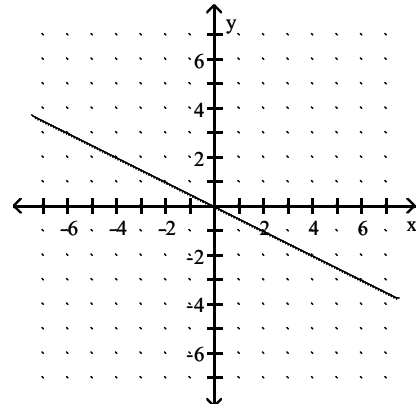

D) $D = (-\infty, \infty), R = (-\infty, \infty)$

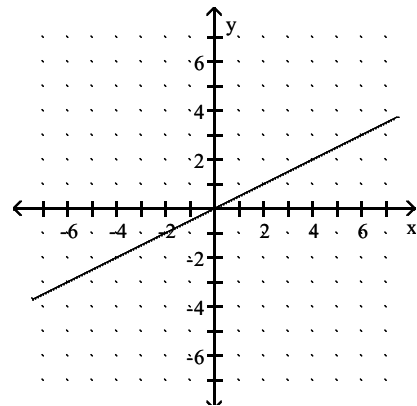

Answer: D

214) $h(x) = 5$

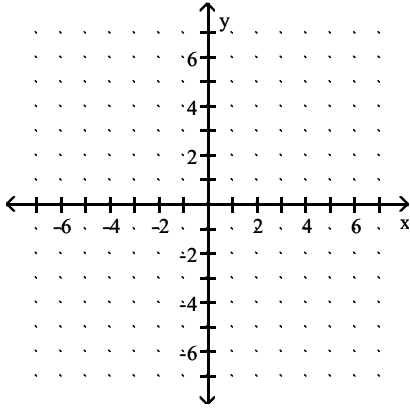

A) $D = \{5\}$, $R = (-\infty, \infty)$
constant function

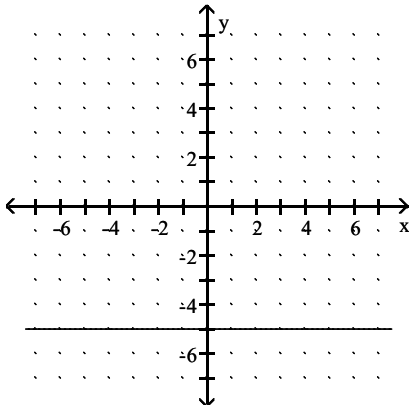

C) $D = (-\infty, \infty)$, $R = \{5\}$
constant function

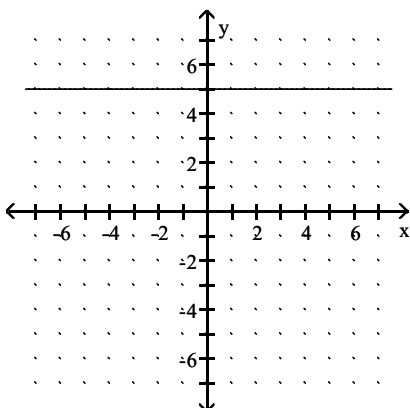

B) $D = (-\infty, \infty)$, $R = \{5\}$
constant function

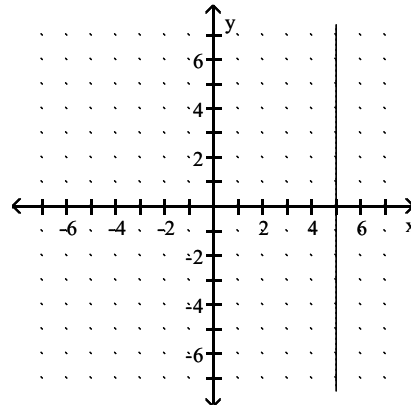

D) $D = \{5\}$, $R = (-\infty, \infty)$
constant function

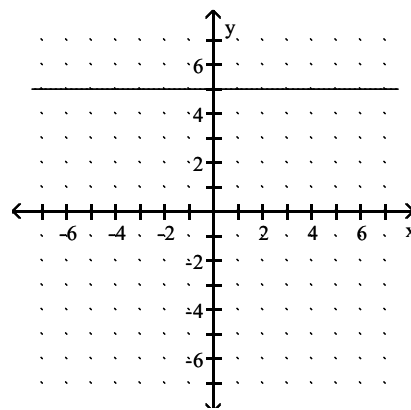

Answer: C

Graph the line and give the domain and the range.

215) $y = -4$

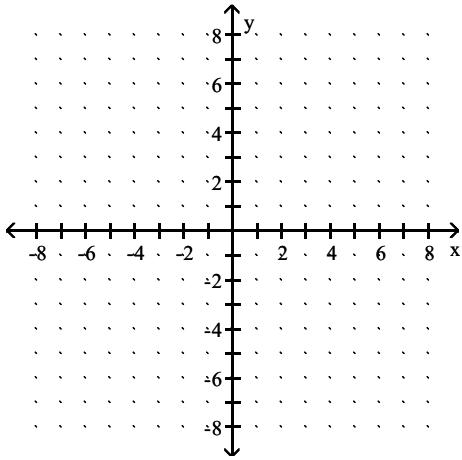

A) $D = (-\infty, \infty)$, $R = \{-4\}$

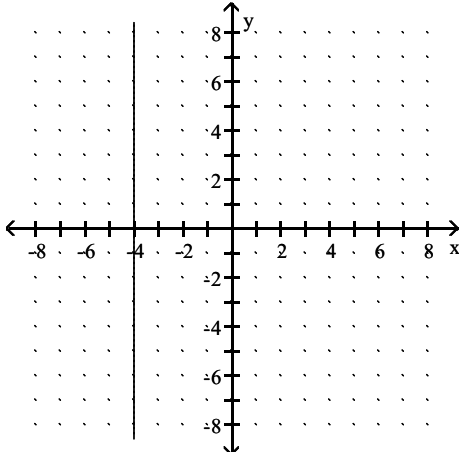

C) $D = (-\infty, \infty)$, $R = \{-4\}$

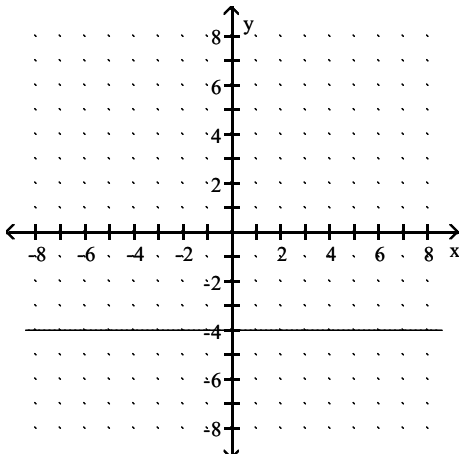

B) $D = \{-4\}$, $R = (-\infty, \infty)$

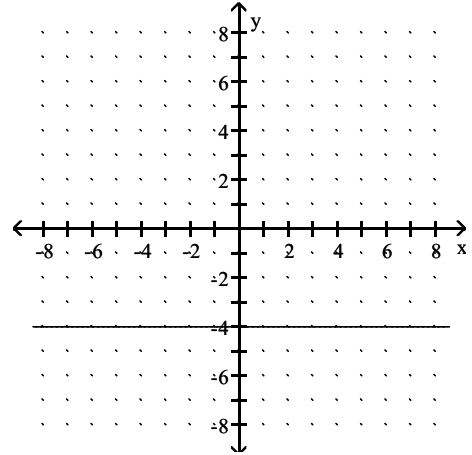

D) $D = \{-4\}$, $R = (-\infty, \infty)$

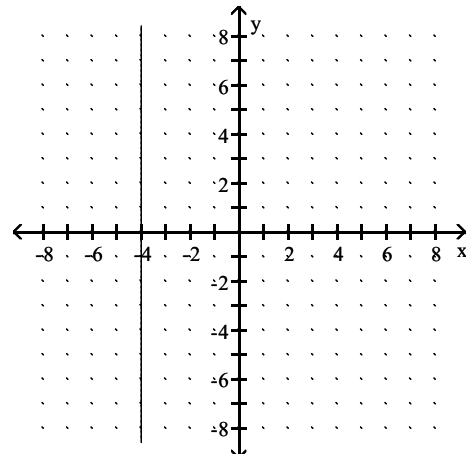

Answer: C

216) $x = 5$

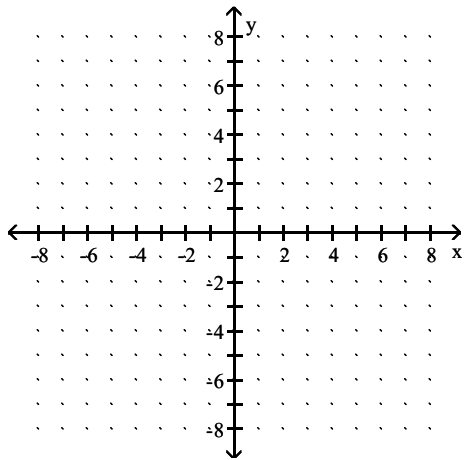

A) $D = (-\infty, \infty)$, $R = \{5\}$

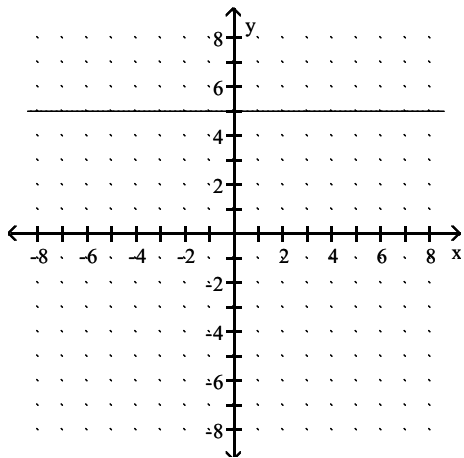

C) $D = \{5\}$, $R = (-\infty, \infty)$

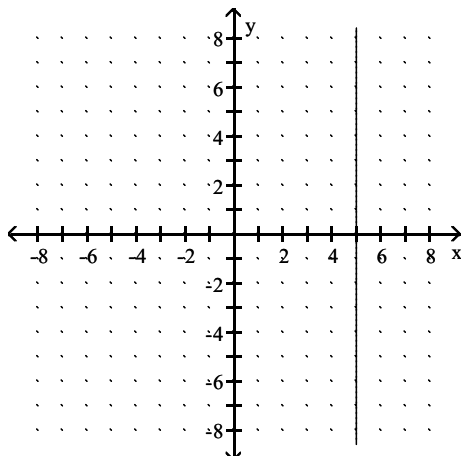

B) $D = (-\infty, \infty)$, $R = \{5\}$

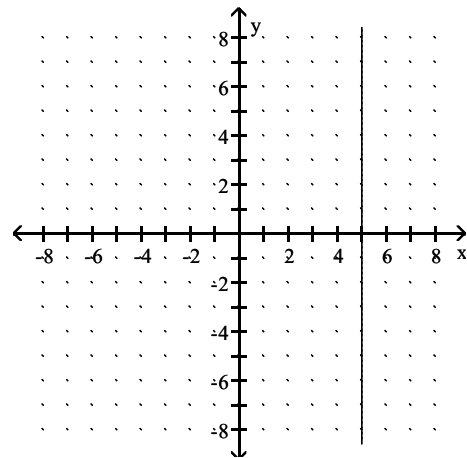

D) $D = \{5\}$, $R = (-\infty, \infty)$

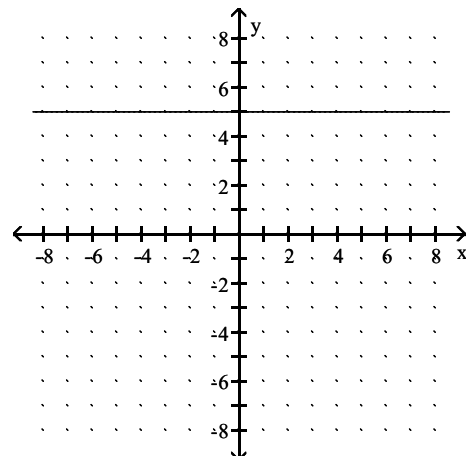

Answer: C

217) $x + 1 = 0$

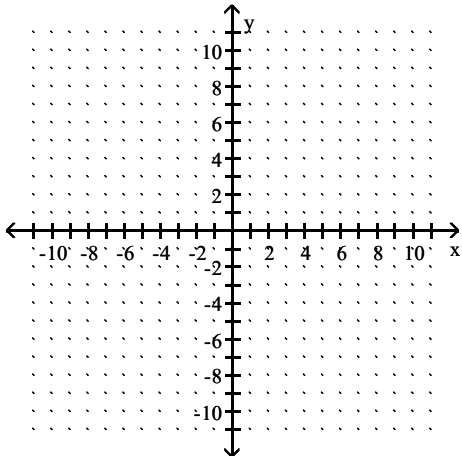

A) $D = (-\infty, \infty)$, $R = \{-1\}$

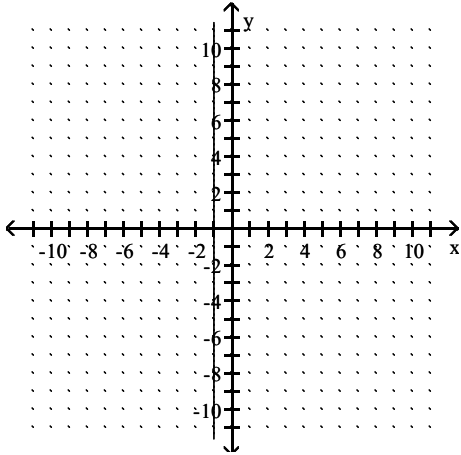

C) $D = (-\infty, \infty)$, $R = \{-1\}$

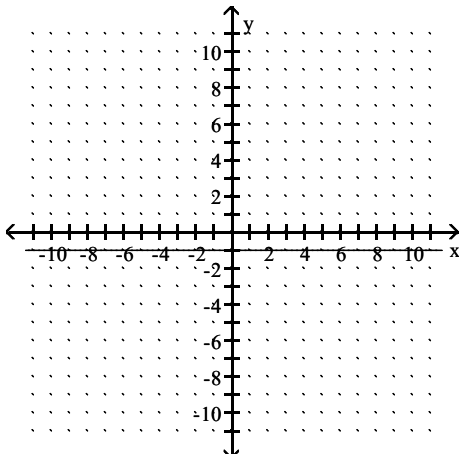

B) $D = (-\infty, \infty)$, $R = (-\infty, \infty)$

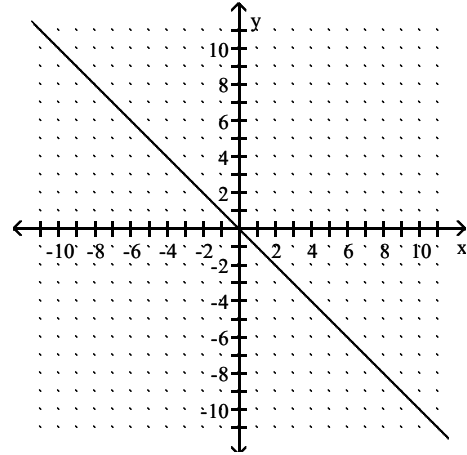

D) $D = \{-1\}$, $R = (-\infty, \infty)$

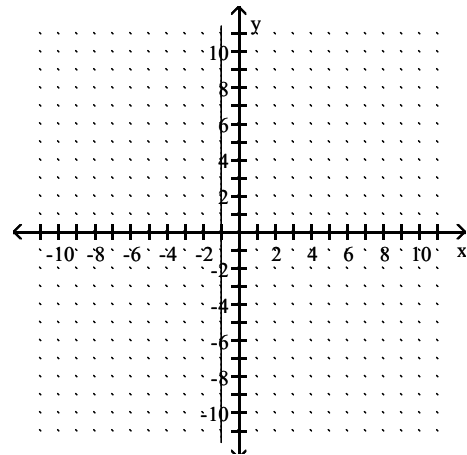

Answer: D

218) $y + 1 = 0$

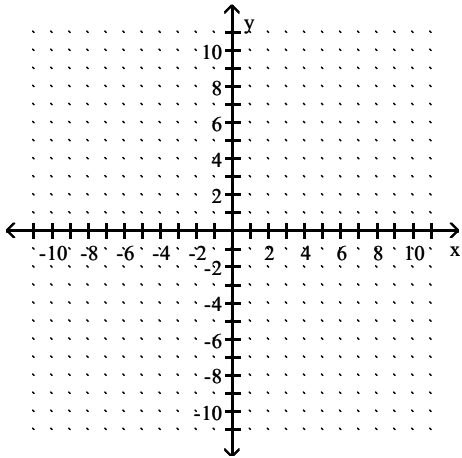

A) $D = \{-1\}, R = (-\infty, \infty)$

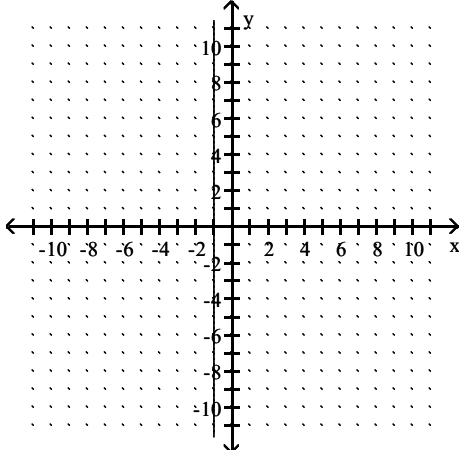

C) $D = (-\infty, \infty), R = (-\infty, \infty)$

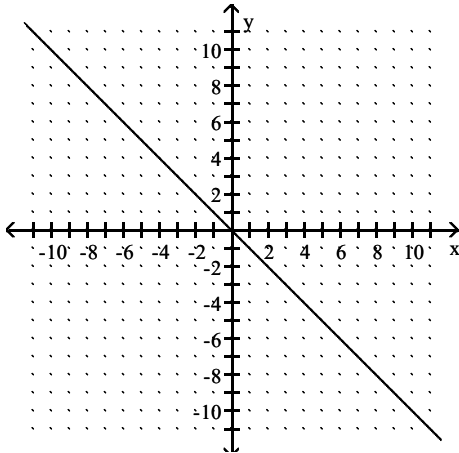

B) $D = (-\infty, \infty), R = \{-1\}$

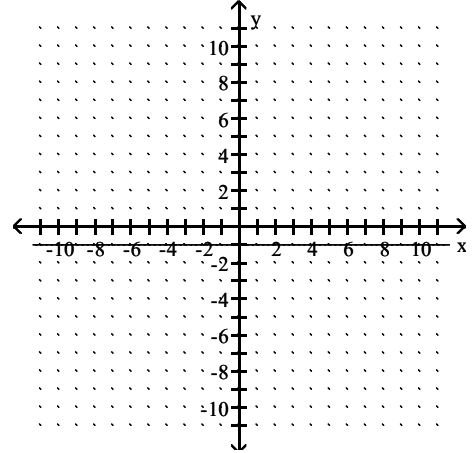

D) $D = (-\infty, \infty), R = \{-1\}$

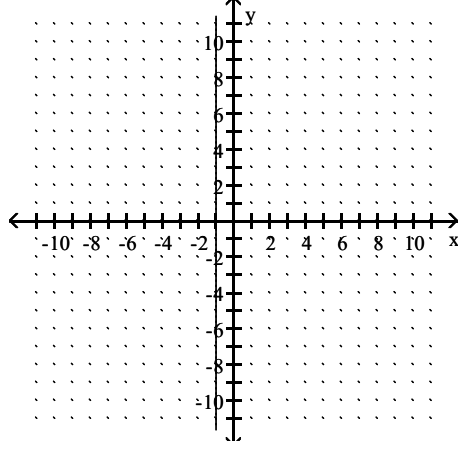

Answer: B

219) $-3x + 27 = 0$

A) $D = (-\infty, \infty), R = \{9\}$

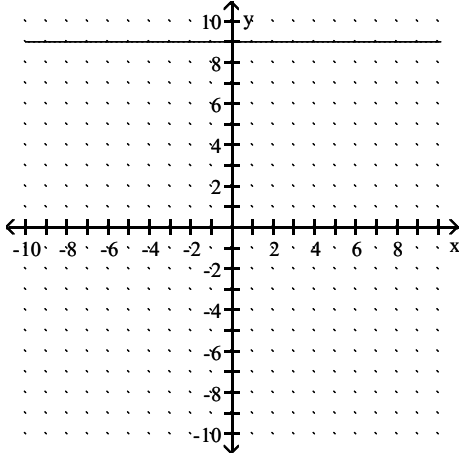

B) $D = \{9\}, R = (-\infty, \infty)$

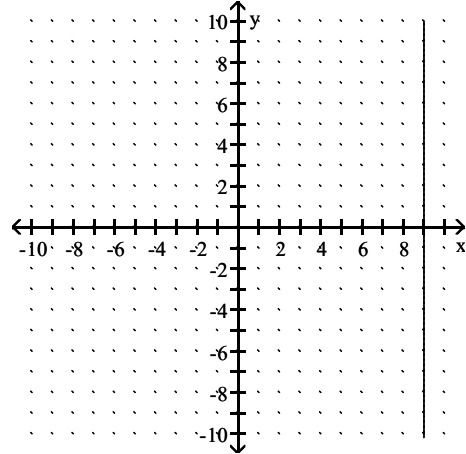

C) $D = (-\infty, \infty), R = \{-9\}$

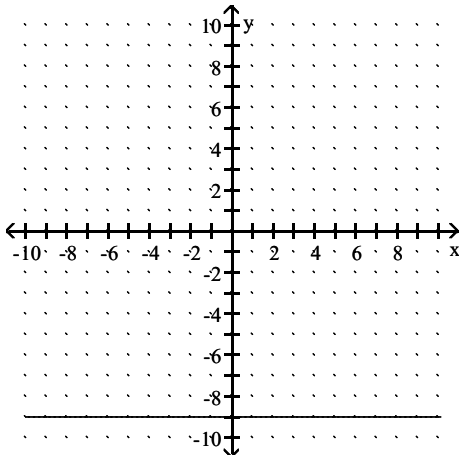

D) $D = \{-9\}, R = (-\infty, \infty)$

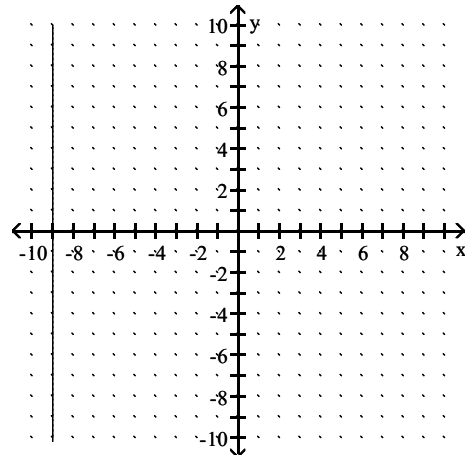

Answer: B

220) $3y + 18 = 0$

A) $D = \{-6\}, R = (-\infty, \infty)$

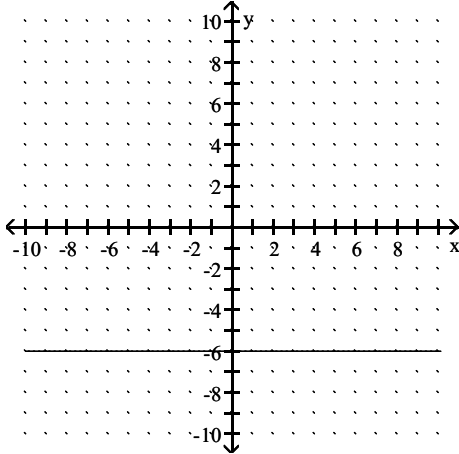

B) $D = (-\infty, \infty), R = \{-6\}$

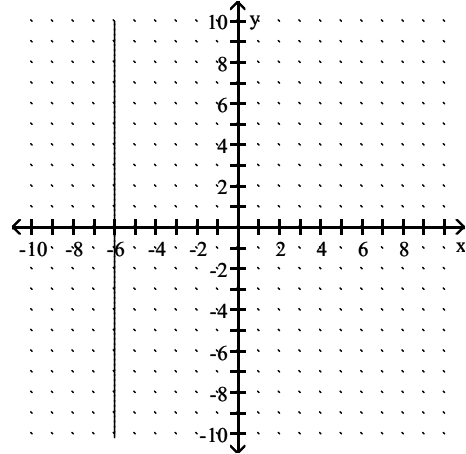

C) $D = \{-6\}, R = (-\infty, \infty)$

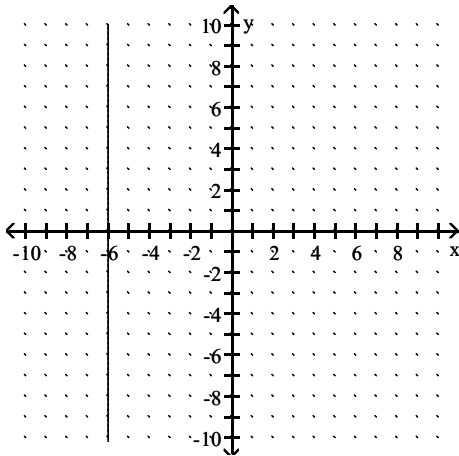

D) $D = (-\infty, \infty), R = \{-6\}$

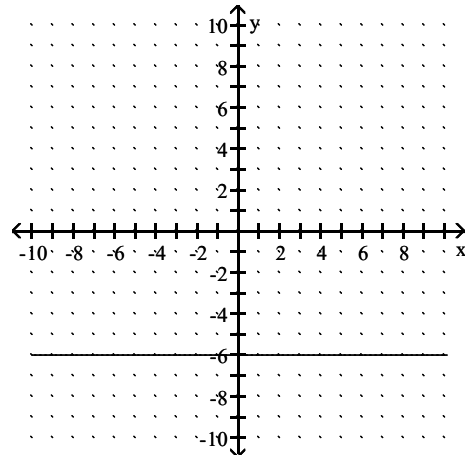

Answer: D

221) $4x - 12y = 24$

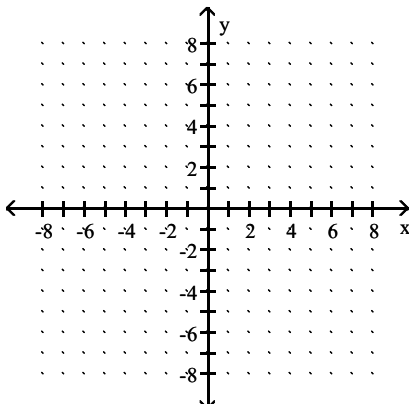

A) $D = (-\infty, \infty)$, $R = (-\infty, \infty)$

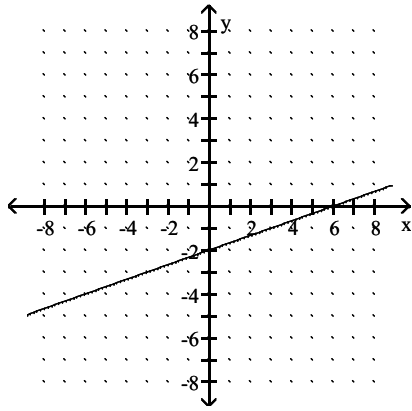

B) $D = (-\infty, \infty)$, $R = (-\infty, \infty)$

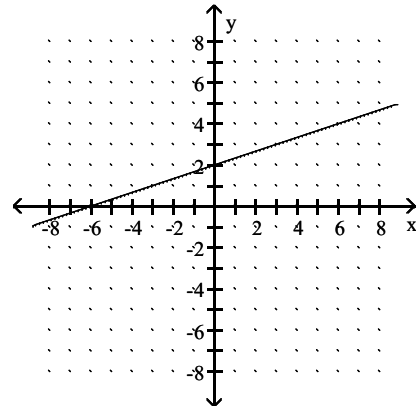

C) $D = (-\infty, \infty)$, $R = (-\infty, \infty)$

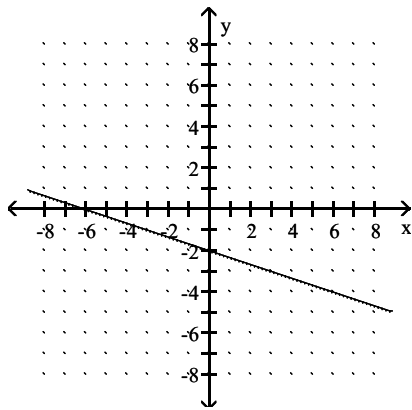

D) $D = (-\infty, \infty)$, $R = (-\infty, \infty)$

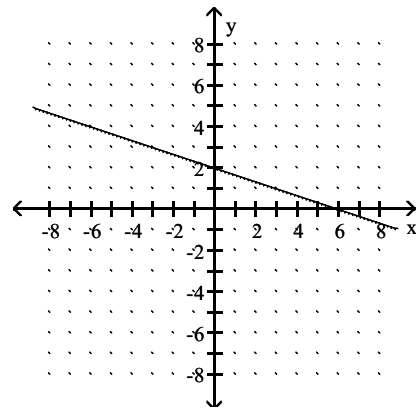

Answer: A

222) $2x - 10y = 0$

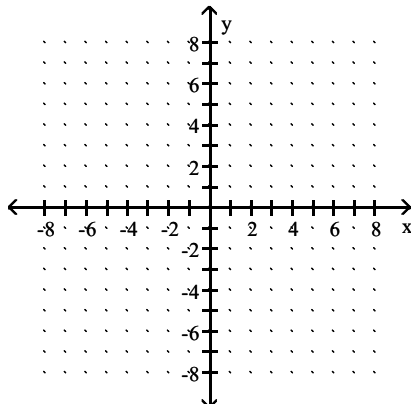

A) $D = (-\infty, \infty)$, $R = (-\infty, \infty)$

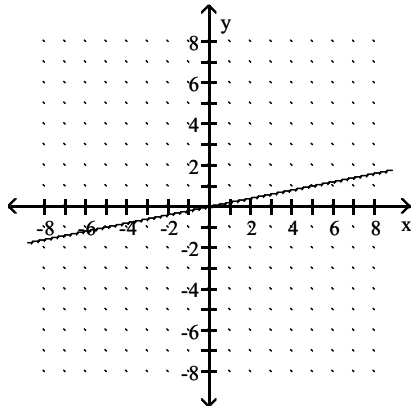

B) $D = (-\infty, \infty)$, $R = (-\infty, \infty)$

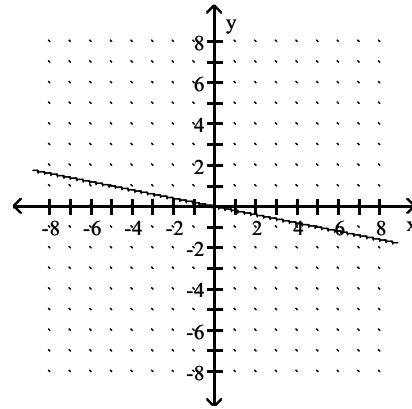

C) $D = (-\infty, \infty)$, $R = (-\infty, \infty)$

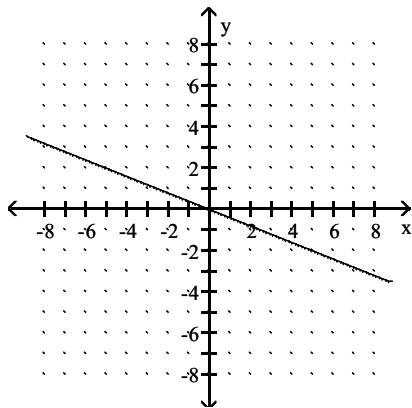

D) $D = (-\infty, \infty)$, $R = (-\infty, \infty)$

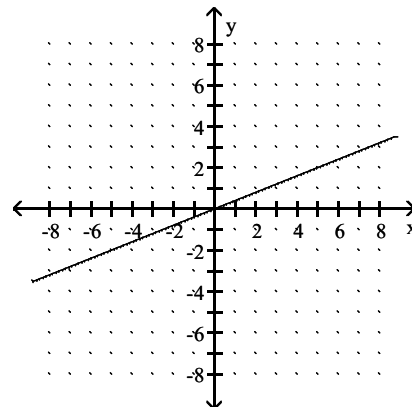

Answer: A

Find the slope of the line satisfying the given conditions.

223) through $(-6, -7)$ and $(5, 1)$

A) $-\frac{11}{8}$

B) $-\frac{8}{11}$

C) $\frac{11}{8}$

D) $\frac{8}{11}$

Answer: D

224) through $(-7, -5)$ and $(-1, 8)$

A) $-\frac{13}{6}$

B) $\frac{6}{13}$

C) $-\frac{6}{13}$

D) $\frac{13}{6}$

Answer: D

225) through $(1, -7)$ and $(-9, 9)$

A) $-\frac{5}{8}$

B) $\frac{5}{8}$

C) $\frac{8}{5}$

D) $-\frac{8}{5}$

Answer: D

226) through $(6, -2)$ and $(4, 7)$

A) $-\frac{2}{9}$

B) $\frac{2}{9}$

C) $-\frac{9}{2}$

D) $\frac{9}{2}$

Answer: C

227) through (3, -8) and (3, 6)

A) 0

B) 14

C) undefined

D) -14

Answer: C

228) through (-9, -1) and (-1, -1)

A) undefined

B) 8

C) 0

D) -8

Answer: C

229) vertical, through (3, 4)

A) 1

B) 0

C) -1

D) undefined

Answer: D

230) horizontal, through (9, 5)

A) 0

B) 1

C) undefined

D) -1

Answer: A

Find the slope of the line and sketch the graph.

231) $y + 5 = 0$

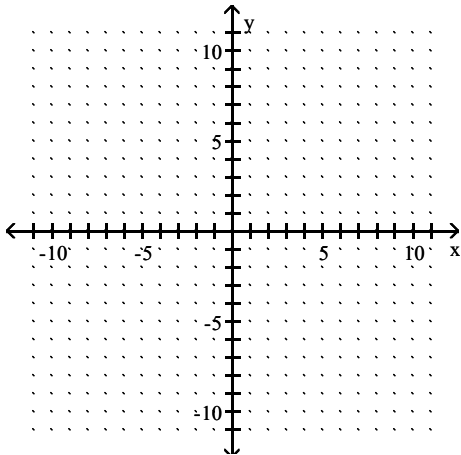

A) $m = 0$

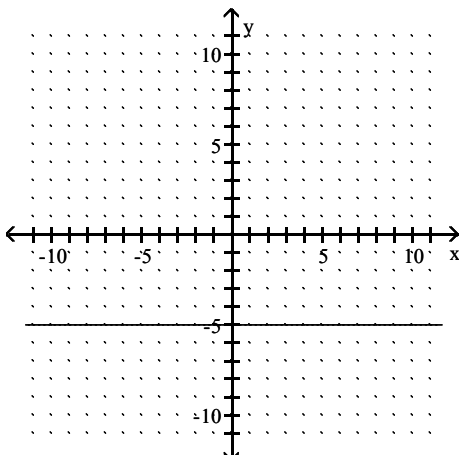

B) m : undefined

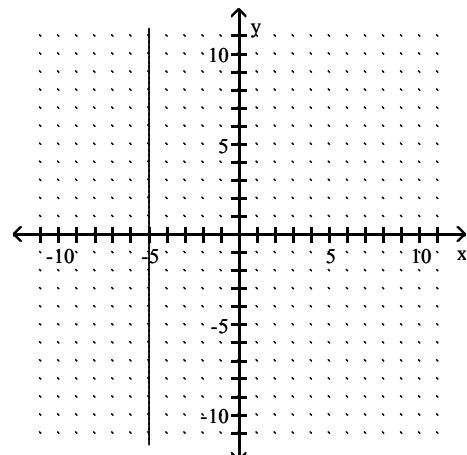

C) $m = -\frac{1}{5}$

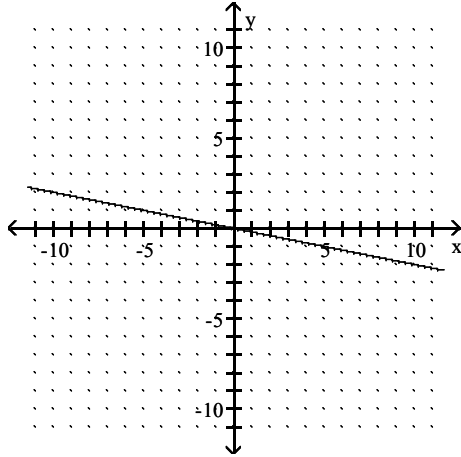

D) $m = -5$

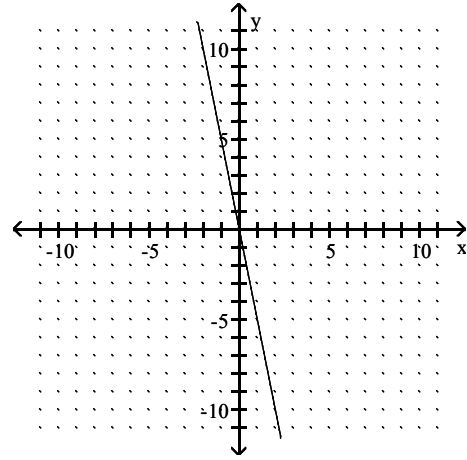

Answer: A

232) $y = 5x$

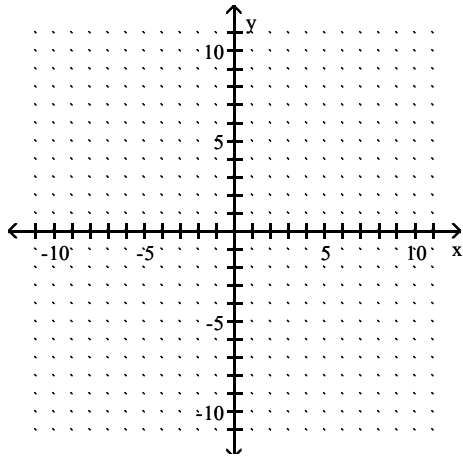

A) $m = -5$

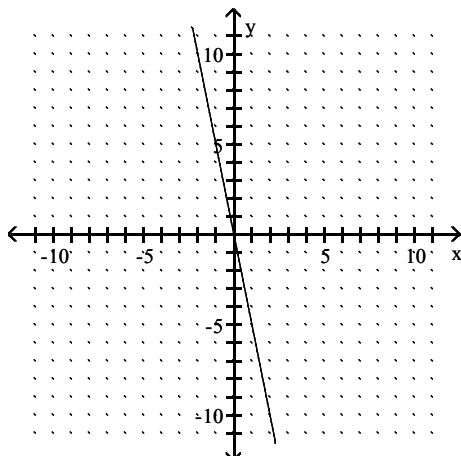

B) $m = \frac{1}{5}$

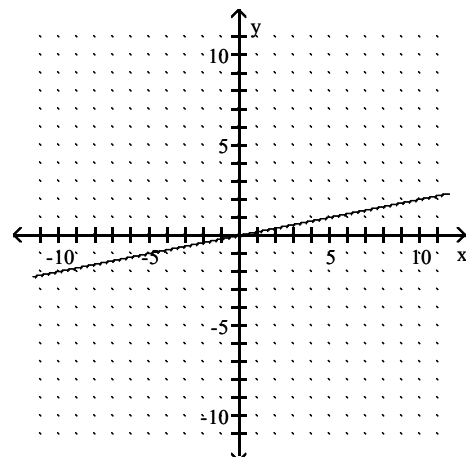

C) $m = 0$

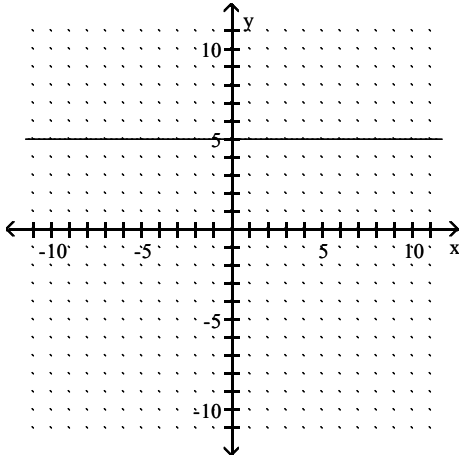

D) $m = 5$

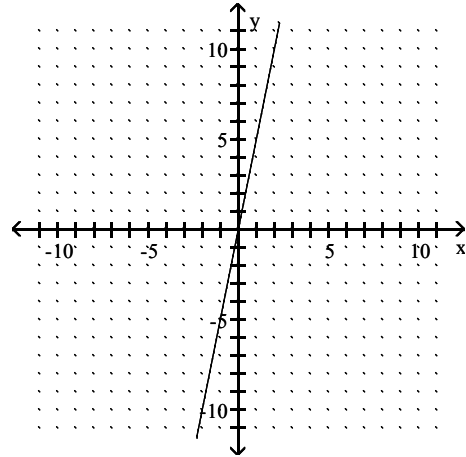

Answer: D

233) $y = -5x - 1$

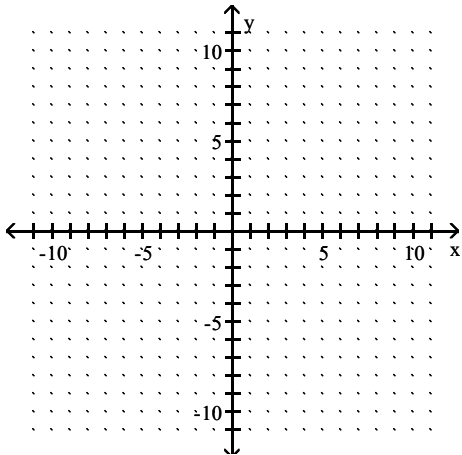

A) $m = -1$

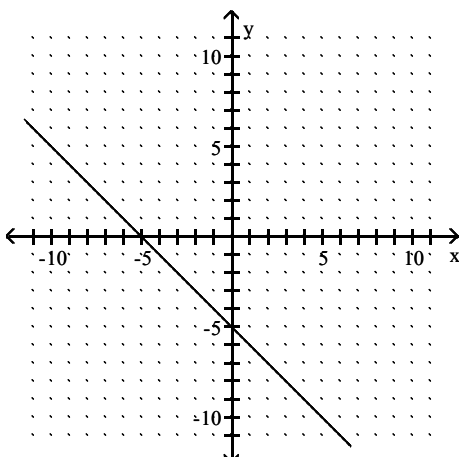

B) $m = 5$

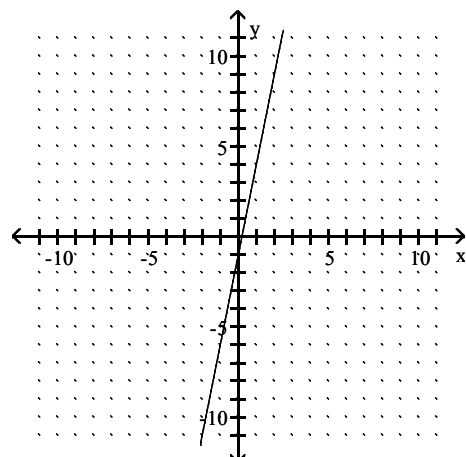

C) $m = -\frac{1}{5}$

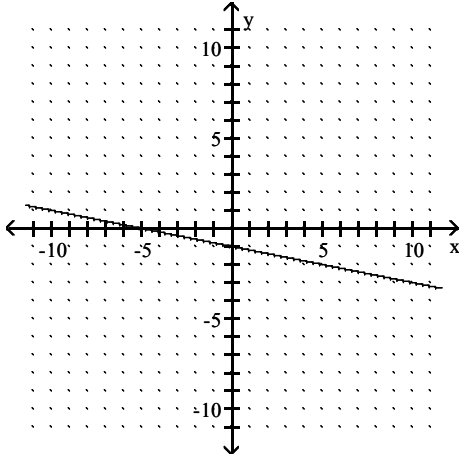

D) $m = -5$

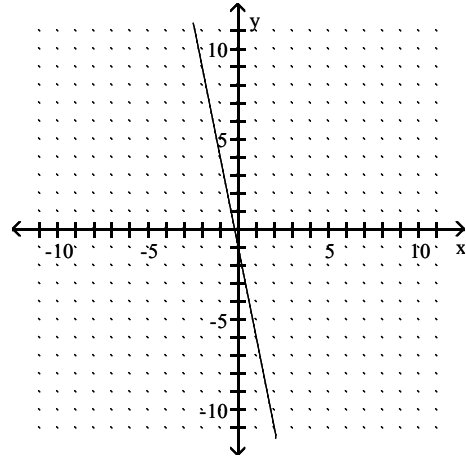

Answer: D

234) $-4y = 3x$

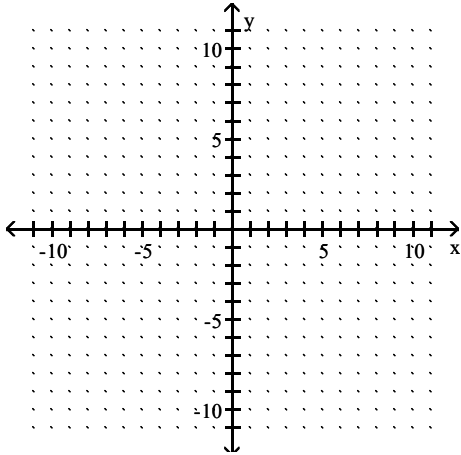

A) $m = -\frac{4}{3}$

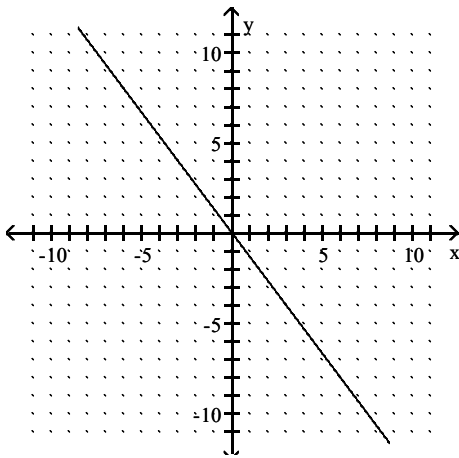

B) $m = \frac{4}{3}$

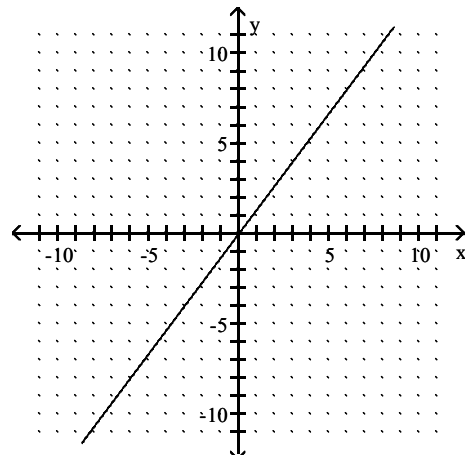

C) $m = \frac{3}{4}$

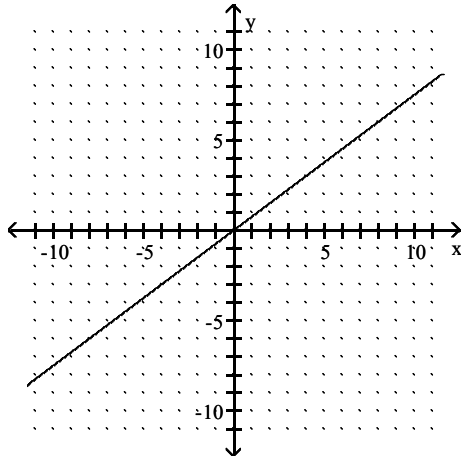

D) $m = -\frac{3}{4}$

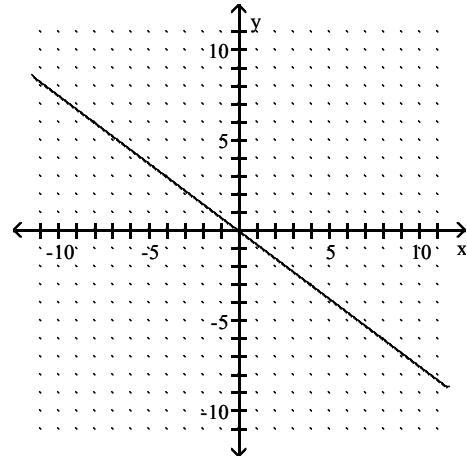

Answer: D

235) $3x + 4y = 14$

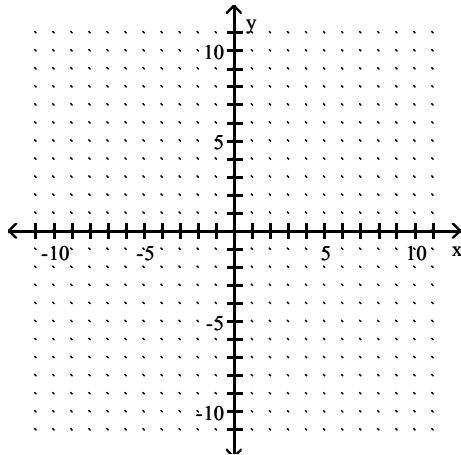

A) $m = -\frac{4}{3}$

B) $m = \frac{4}{3}$

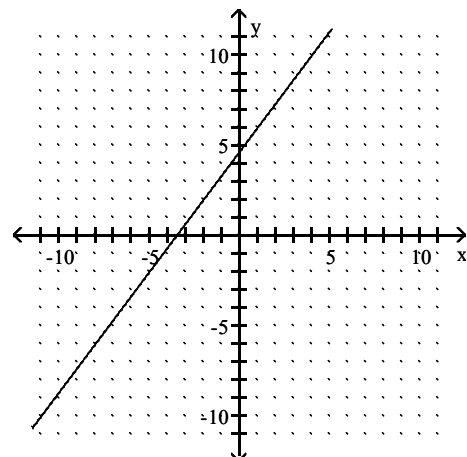
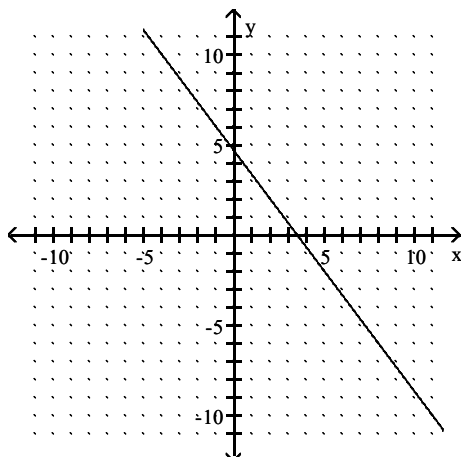

C) $m = -\frac{3}{4}$

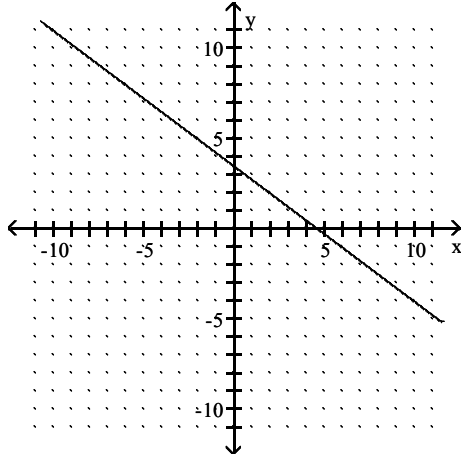

D) $m = \frac{3}{4}$

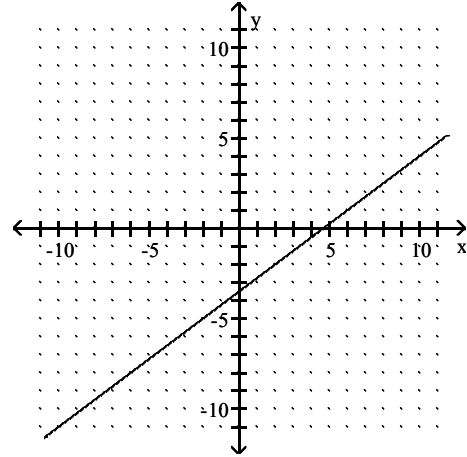

Answer: C

236) $2x - 5y = -6$

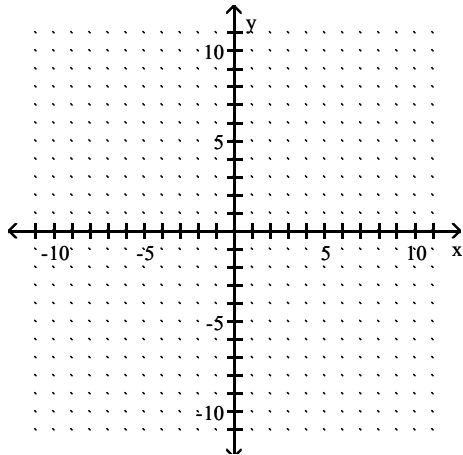

A) $m = \frac{5}{2}$

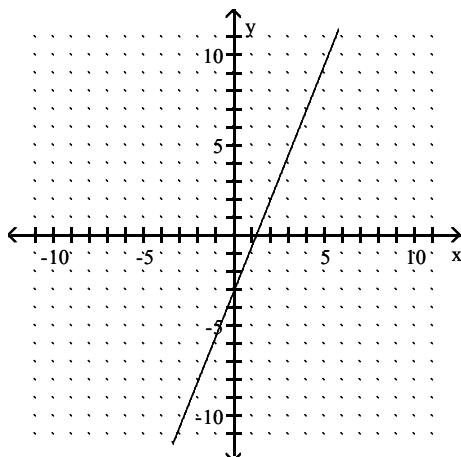

B) $m = -\frac{2}{5}$

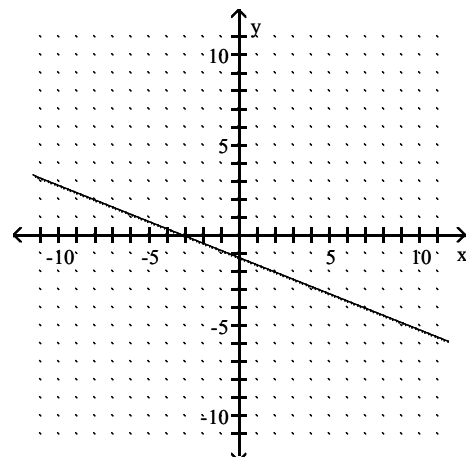

C) $m = -\frac{5}{2}$

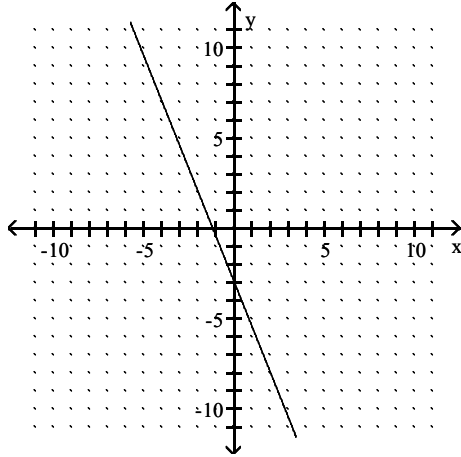

D) $m = \frac{2}{5}$

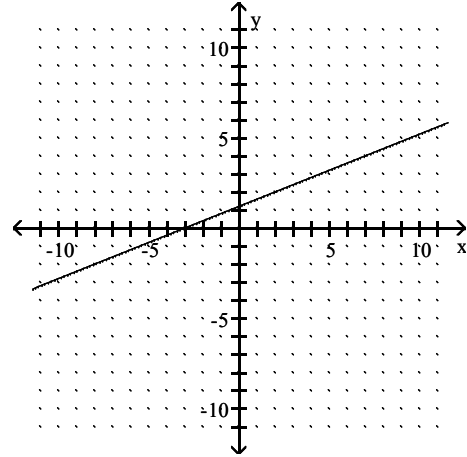

Answer: D

Graph the line described.

237) through $(0, 2)$; $m = \frac{1}{6}$

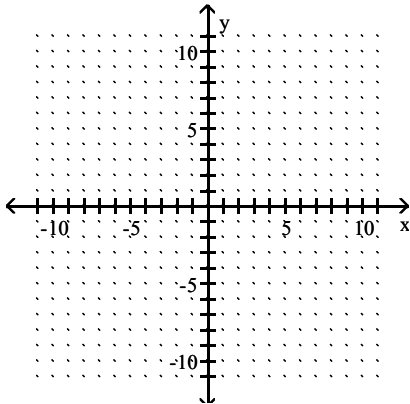

A)

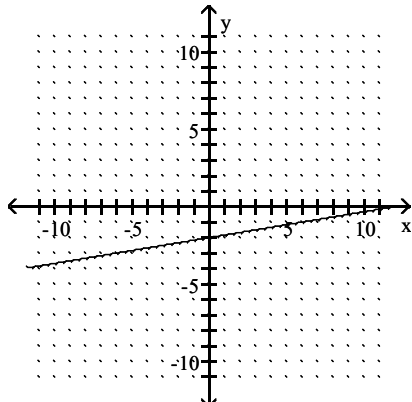

B)

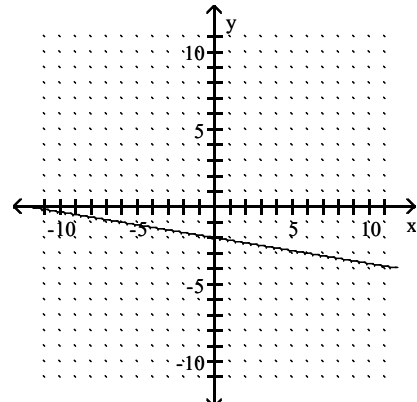

C)

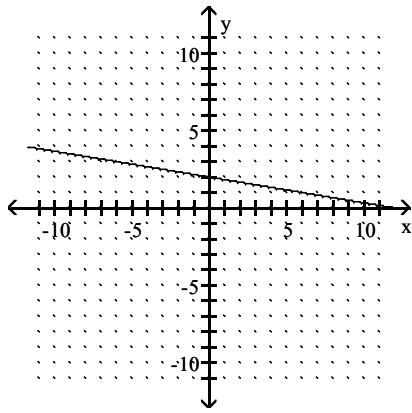

D)

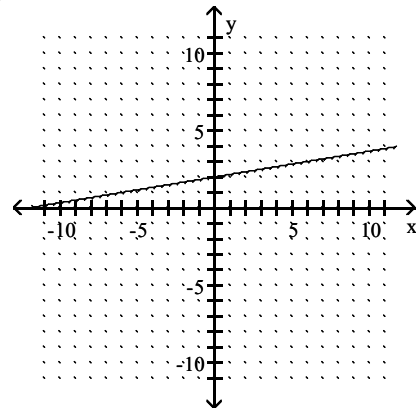

Answer: D

238) through $(-2, -4)$; $m = 5$

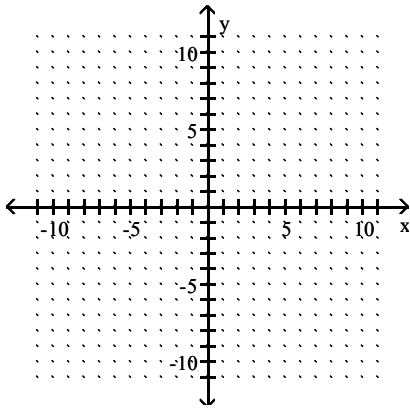

A)

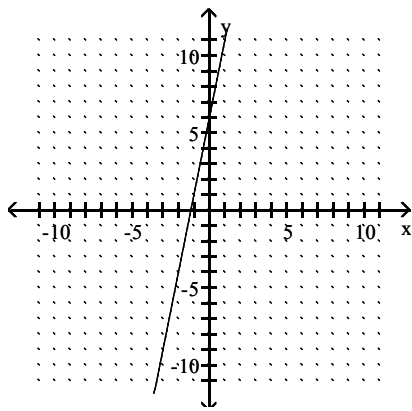

B)

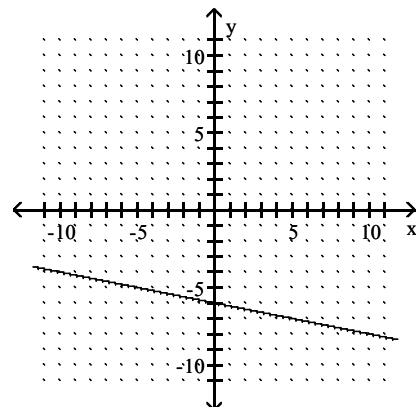

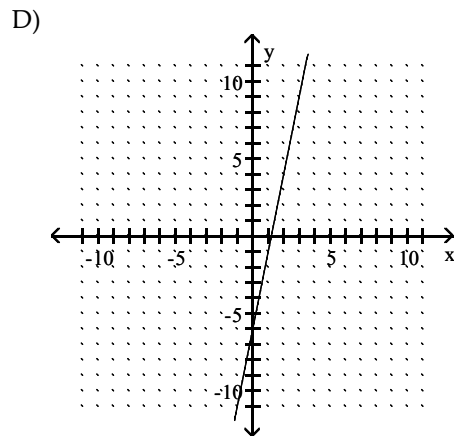
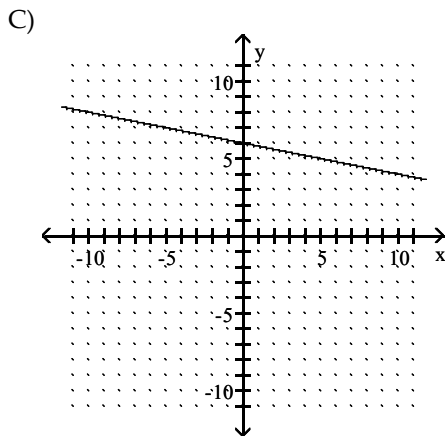

Answer: A

239) through $(0, 6)$; $m = -2$

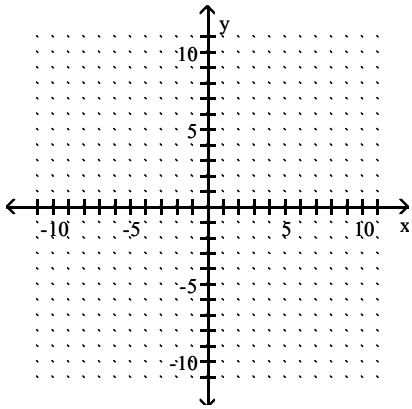

A)

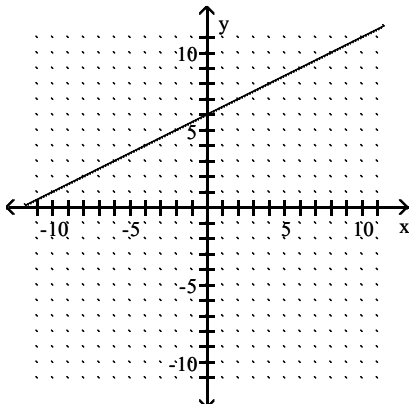

B)

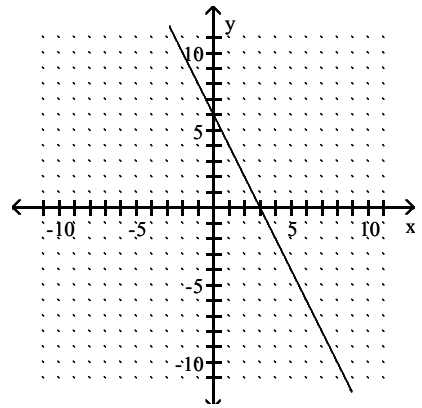

C)

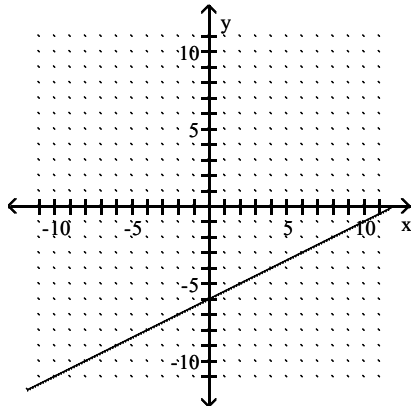

Answer: B

240) through $(0, 6)$; $m = -\frac{1}{6}$

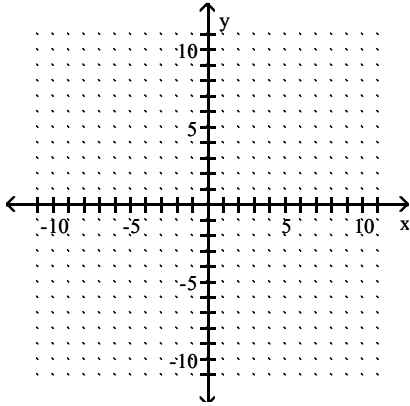

A)

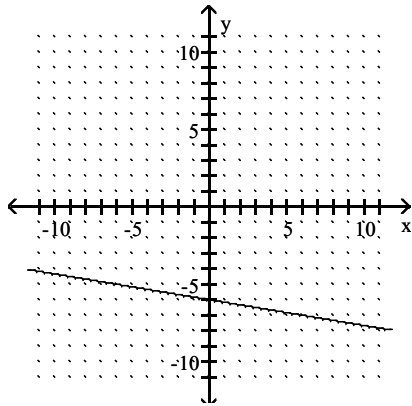

D)

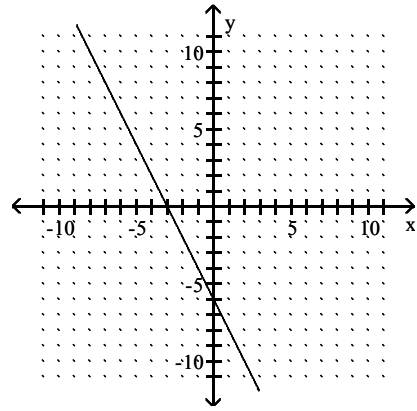

B)

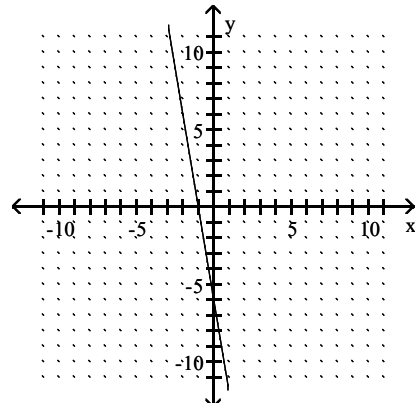

C)

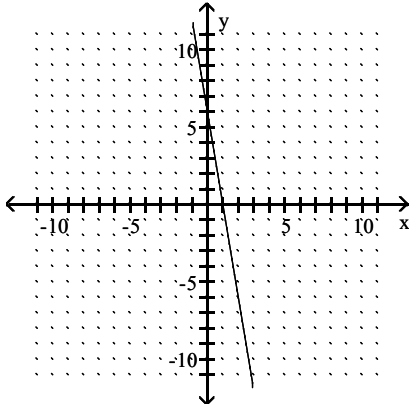

D)

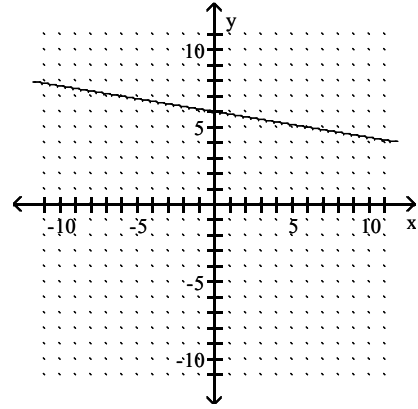

Answer: D

241) through $(10, 0)$; $m = -\frac{1}{2}$

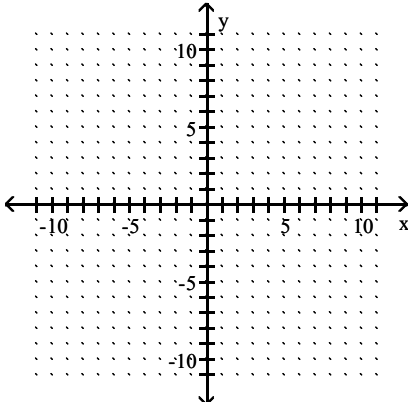

A)

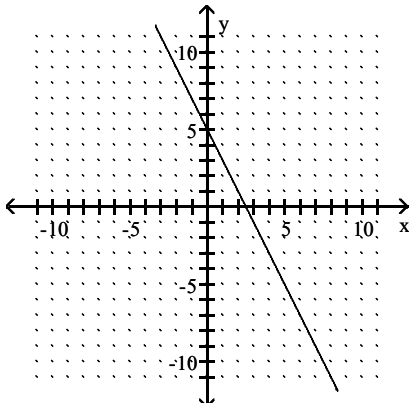

B)

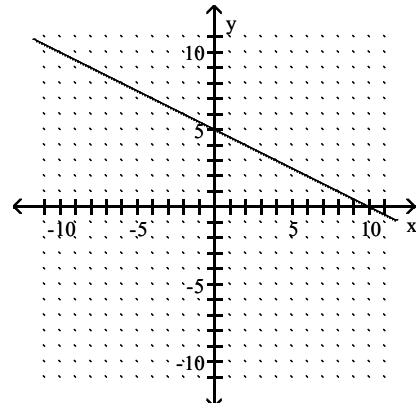

C)

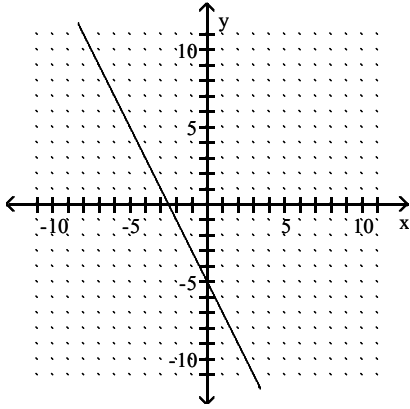

D)

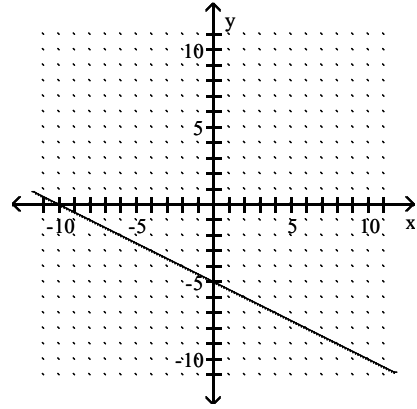

Answer: B

242) through $(-10, 6)$; $m = 0$

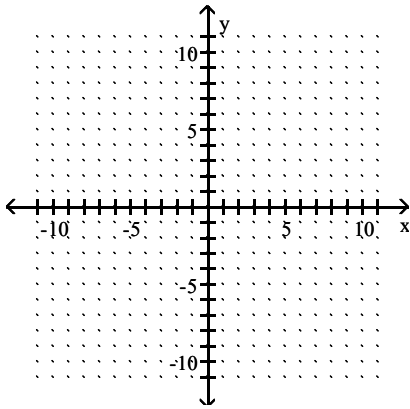

A)

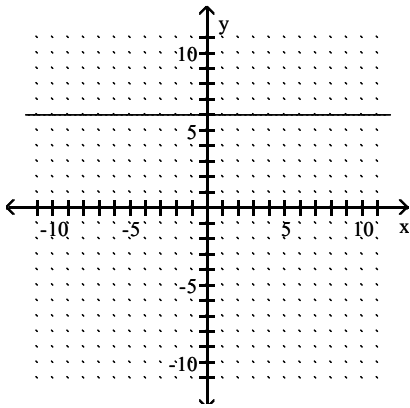

B)

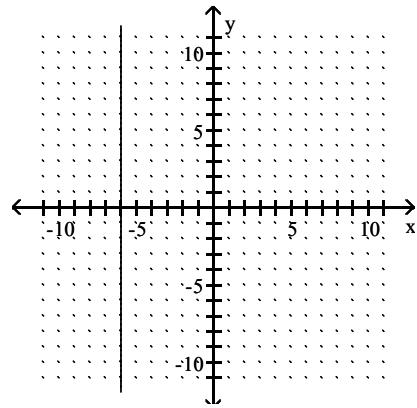

C)

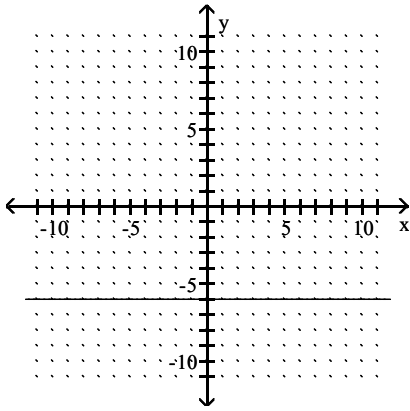

D)

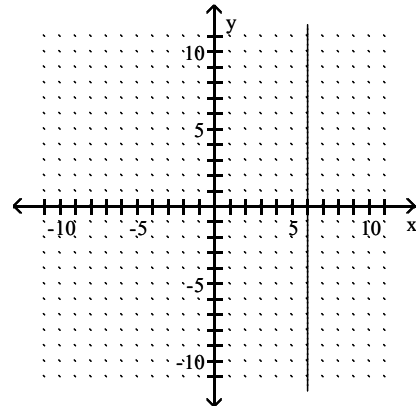

Answer: A

243) through $(5, -3)$; $m = 0$

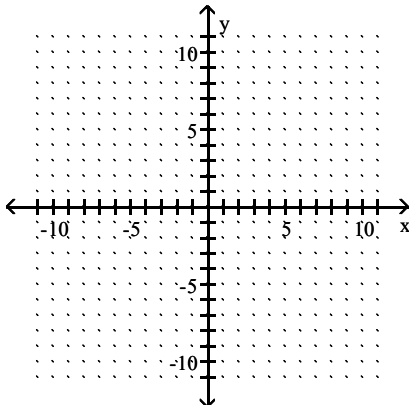

A)

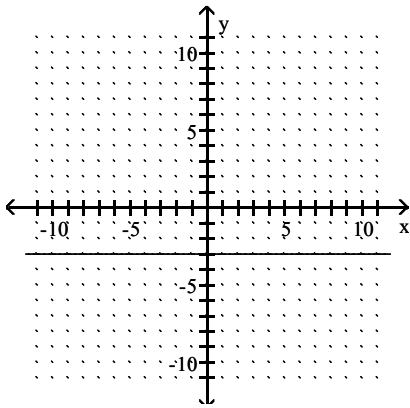

B)

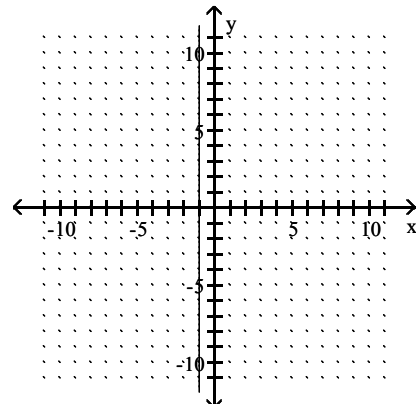

C)

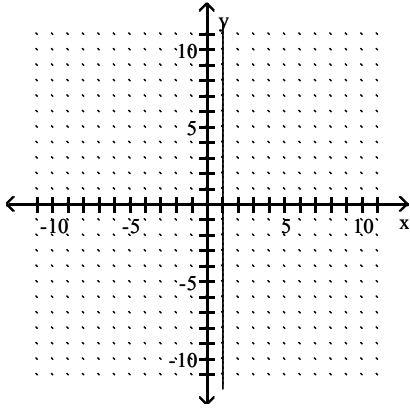

D)

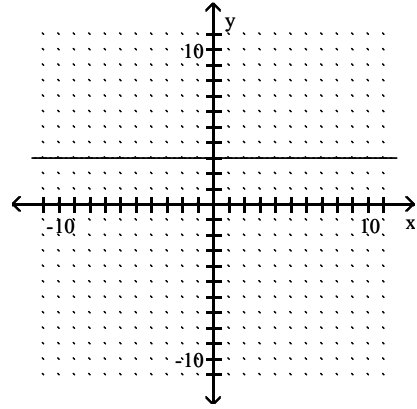

Answer: A

244) through (1, 9); undefined slope

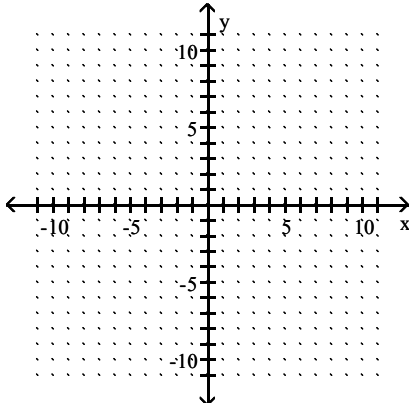

A)

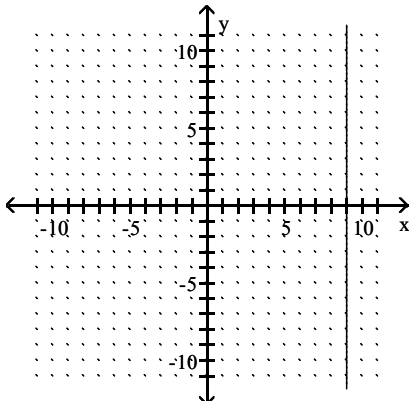

B)

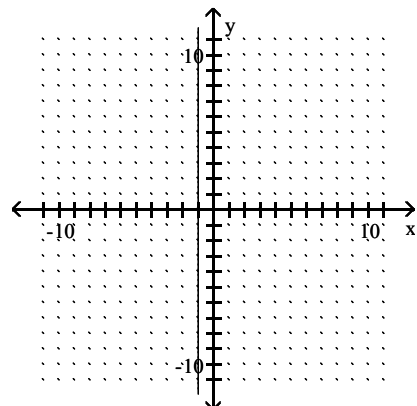

C)

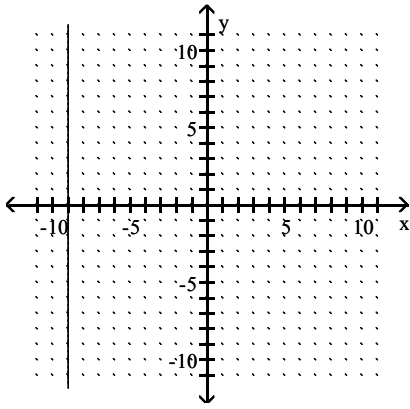

D)

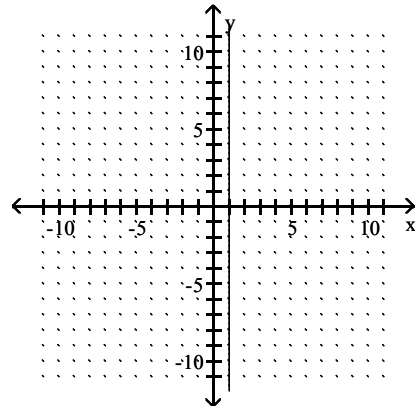

Answer: D

Choose the value which could represent the slope of the line. Assume that the scale on the x-axis is the same as the scale on the y-axis.

245)

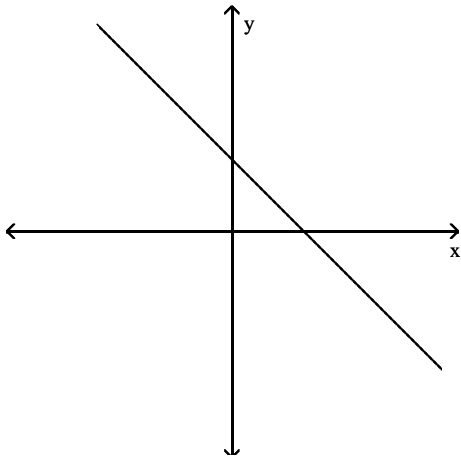

A) -4

B) 4

C) 1

D) -1

Answer: D

246)

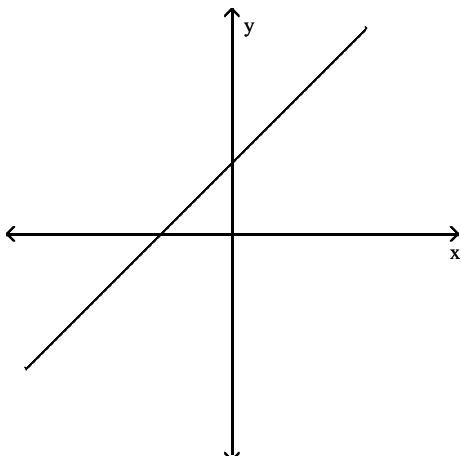

A) -1

B) 4

C) 1

D) -4

Answer: C

247)

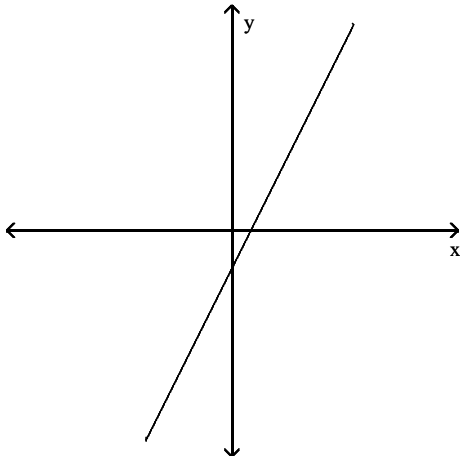

A) -2

B) $\frac{1}{2}$

C) $-\frac{1}{2}$

D) 2

Answer: D

248)

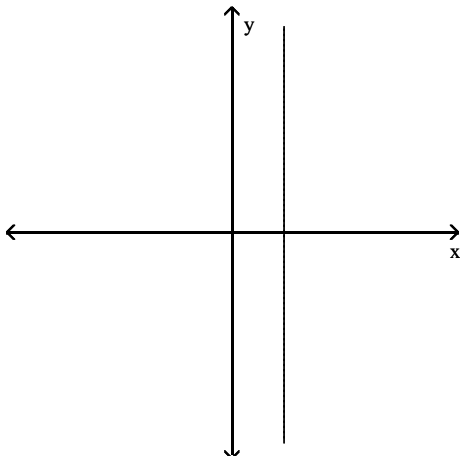

A) $\frac{3}{2}$

B) undefined

C) 0

D) 2

Answer: B

249)

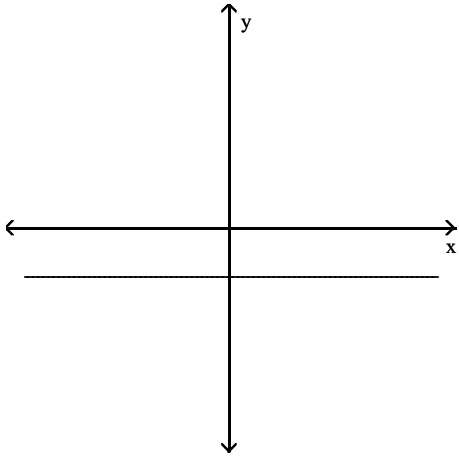

A) 0

B) undefined

C) -2

D) 2

Answer: A

Find the average rate of change illustrated in the graph.

250)

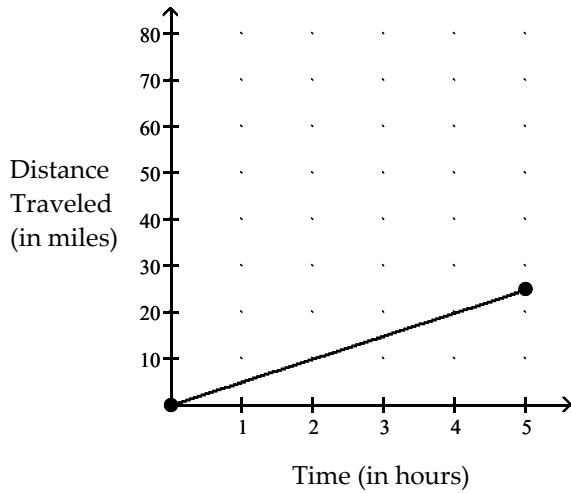

A) 0.2 miles per hour

B) 5 miles per hour

C) 25 miles per hour

D) 2.5 miles per hour

Answer: B

251)

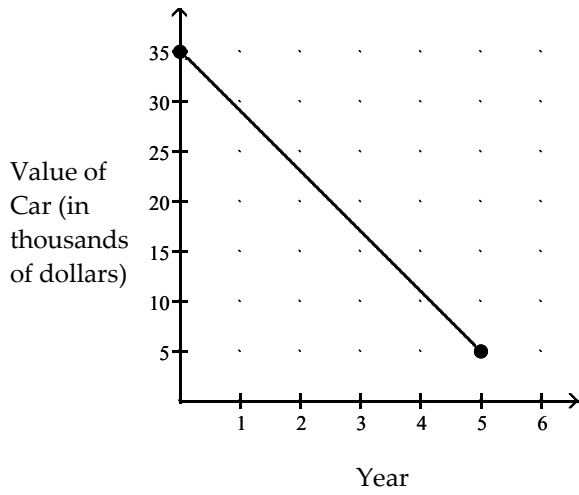

A) -\$7000.00 per year

B) -\$6000.00 per year

C) \$7000.00 per year

D) \$6000.00 per year

Answer: B

252)

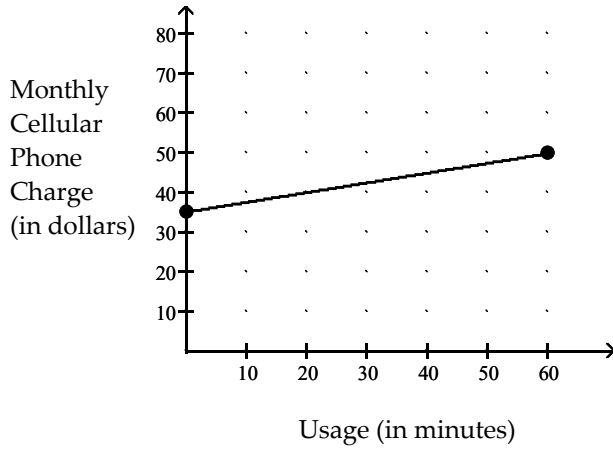

A) \$4.00 per minute

B) \$0.50 per minute

C) \$2.00 per minute

D) \$0.25 per minute

Answer: D

253)

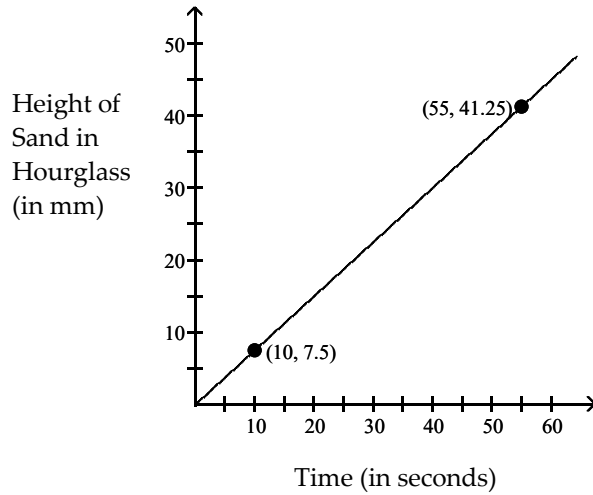

- A) 0.85 mm per second
- C) 1 mm per second

- B) 0.75 mm per second
- D) 1.3 mm per second

Answer: B

Solve the problem.

254) From April through December, the stock price of QRS Company had a roller coaster ride. The chart below indicates the price of the stock at the beginning of each month during that period. Find the average rate of change in price per month between June and September. Round to the nearest cent.

Month	Price
April (x = 1)	116
May	108
June	87
July	101
August	96
September	113
October	92
November	85
December	64

A) \$8.67 per month

B) \$13.00 per month

C) -\$8.67 per month

D) -\$13.00 per month

Answer: A

- 255) Along with incomes, people's charitable contributions have steadily increased over the past few years. The table below shows the average deduction for charitable contributions reported on individual income tax returns over 6 years. Find the average rate of change per year between year 3 and year 5.

Year	Charitable Contributions
1	\$1600
2	\$2430
3	\$2500
4	\$2790
5	\$3030
6	\$3140

- A) \$300 per year B) \$320 per year C) \$530 per year D) \$265 per year

Answer: D

- 256) The rate of return of certain investments increases as the risk factor of the investment increases. An investment with a risk factor of 2 has a rate of return of 5.0%. An investment with a risk factor of 20 has a rate of return of 12.0%. What is the average rate of change in return per unit of risk? Round to two decimal places.

- A) 1.50% per unit risk B) 2.57% per unit risk C) 0.67% per unit risk D) 0.39% per unit risk

Answer: D

- 257) A deep sea diving bell is being lowered at a constant rate. After 8 minutes, the bell is at a depth of 400 ft. After 45 minutes the bell is at a depth of 1800 ft. What is the average rate of change of depth? Round to one decimal place.

- A) 31.1 ft per minute B) 0.03 ft per minute C) 37.8 ft per minute D) 40.0 ft per minute

Answer: C

- 258) The linear function $f(x) = 1.8x + 22$ models the percentage of people, $f(x)$, who graduated from college x years after 1998. Find and interpret the slope.

- A) $m = 22$; the percentage of people graduating from college has increased at a rate of 22% per year since 1998.
 B) $m = -1.8$; the percentage of people graduating from college has decreased at a rate of 1.8% per year since 1998.
 C) $m = 1.8$; the percentage of people graduating from college has decreased at a rate of 1.8% per year since 1998.
 D) $m = 1.8$; the percentage of people graduating from college has increased at a rate of 1.8% per year since 1998.

Answer: D

- 259) A school has just purchased new computer equipment for \$16,000.00. The graph shows the depreciation of the equipment over 5 years. The point (0, 16,000) represents the purchase price and the point (5, 0) represents when the equipment will be replaced. Find and interpret the average rate of change in cost per year.

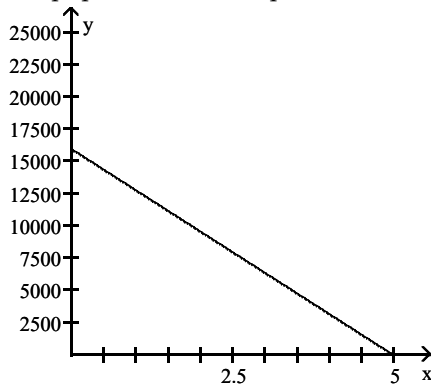

- A) \$3200 per year; the value of the equipment increases by \$3200 per year during these years.
 B) -\$16,000 per year; the value of the equipment decreases by \$16,000 per year during these years.
 C) -\$9600 per year; the value of the equipment decreases by \$9600 per year during these years.
 D) -\$3200 per year; the value of the equipment decreases by \$3200 per year during these years.

Answer: D

- 260) An investment is worth \$3578 in year 0, the initial investment year. By year 4 its value has increased to \$4262. Let y be the value of the investment in the year x . Find and interpret the average rate of change in value per year.

- A) \$4946 per year; the value of the investment increases by \$4946 per year during these years.
 B) \$171 per year; the value of the investment increases by \$171 per year during these years.
 C) -\$171 per year; the value of the investment decreases by \$171 per year during these years.
 D) \$3578 per year; the value of the investment increases by \$3578 per year during these years.

Answer: B

- 261) A faucet is used to add water to a large bottle that already contained some water. After it has been filling for 5 seconds, the gauge on the bottle indicates that it contains 14 ounces of water. After it has been filling for 13 seconds, the gauge indicates the bottle contains 30 ounces of water. Find and interpret the average rate of change in the volume of water per second.

- A) 17 ounces per second; the average rate of change in the volume of water is 17 ounces per second.
 B) 4 ounces per second; the average rate of change in the volume of water is 4 ounces per second.
 C) 2 ounces per second; the average rate of change in the volume of water is 2 ounces per second.
 D) $\frac{1}{2}$ ounce per second; the average rate of change in the volume of water is $\frac{1}{2}$ ounce per second.

Answer: C

- 262) Re grind, Inc. regrinds used typewriter platens. The variable cost to regrind each platen is \$1.90. The total cost to regrind 100 platens is \$300. Find the linear cost function to regrind platens. If reground platens sell for \$8.70 each, how many must be reground and sold to break even?

- A) $C(x) = 1.90x + 300$; 29 platens
 B) $C(x) = 1.90x + 300$; 45 platens
 C) $C(x) = 1.90x + 110$; 17 platens
 D) $C(x) = 1.90x + 110$; 11 platens

Answer: C

263) Northwest Molded molds plastic handles which cost \$0.20 per handle to mold. The fixed cost to run the molding machine is \$3906 per week. If the company sells the handles for \$2.20 each, how many handles must be molded and sold weekly to break even?

- A) 1627 handles B) 1953 handles C) 1302 handles D) 19,530 handles

Answer: B

264) A lumber yard has fixed costs of \$2590.80 per day and variable costs of \$0.34 per board-foot produced. Lumber sells for \$1.54 per board-foot. How many board-feet must be produced and sold daily to break even?

- A) 1439 board-feet B) 7620 board-feet C) 1378 board-feet D) 2159 board-feet

Answer: D

Match the equation with the correct graph.

265) $7x + 4y = -12$

A)

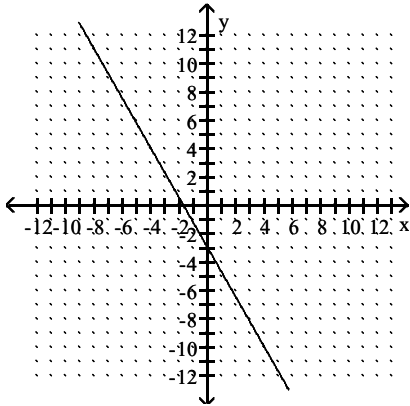

B)

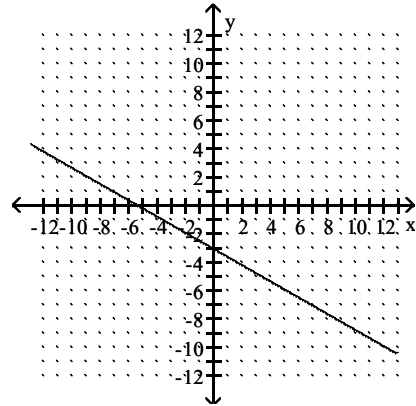

C)

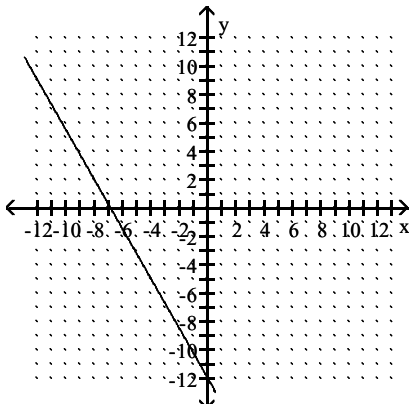

D)

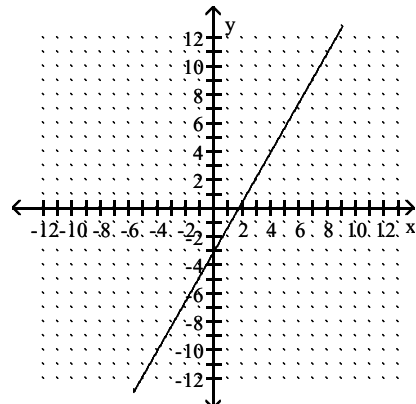

Answer: A

266) $4x - 3y = 3$

A)

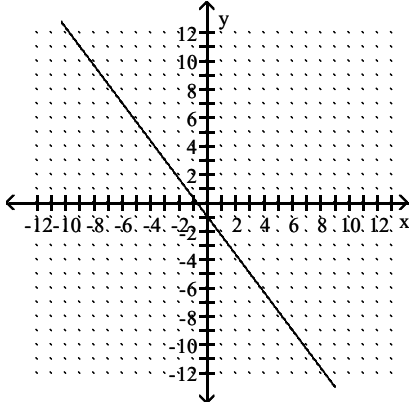

B)

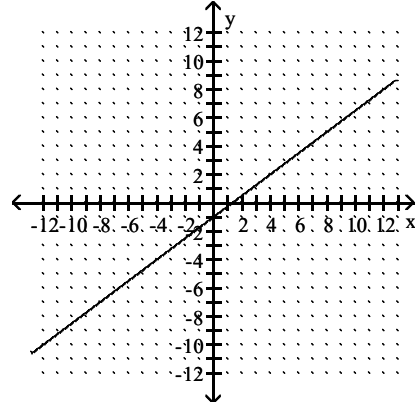

C)

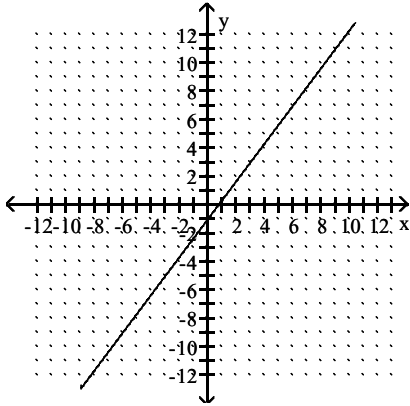

D)

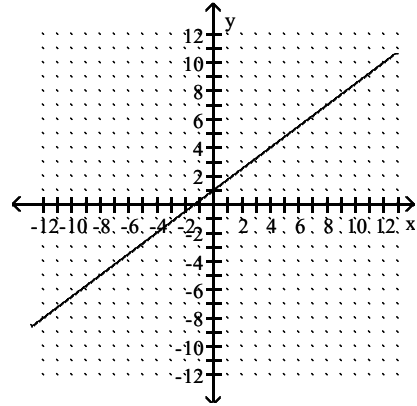

Answer: C

267) $y = \frac{1}{2}x - 2$

A)

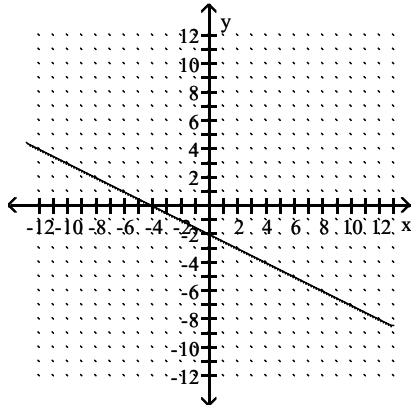

B)

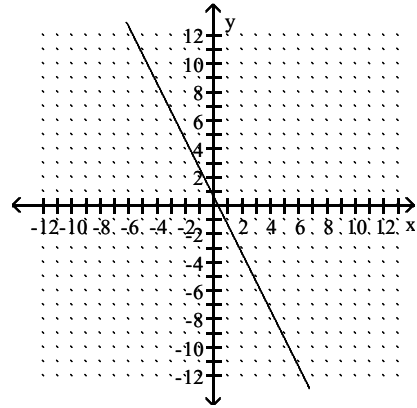

C)

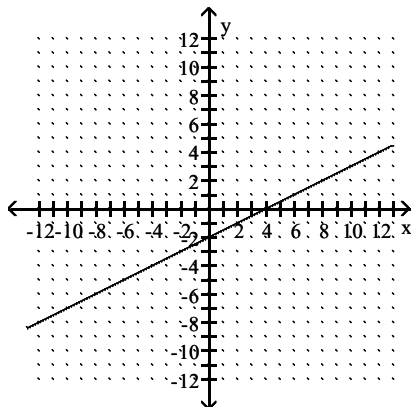

D)

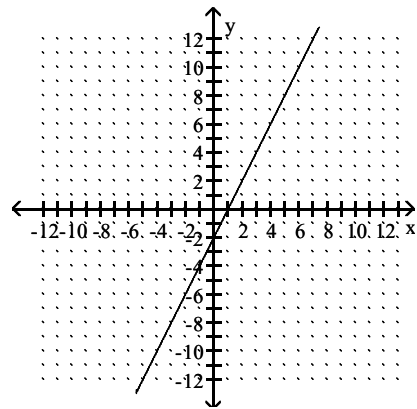

Answer: C

268) $y = -\frac{1}{4}x - 3$

A)

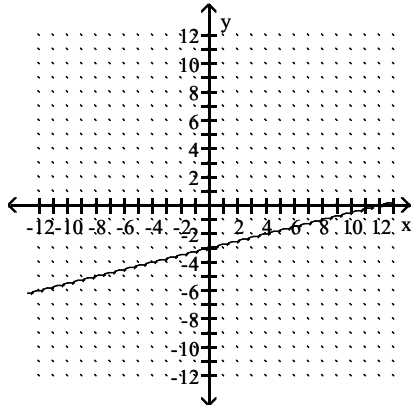

B)

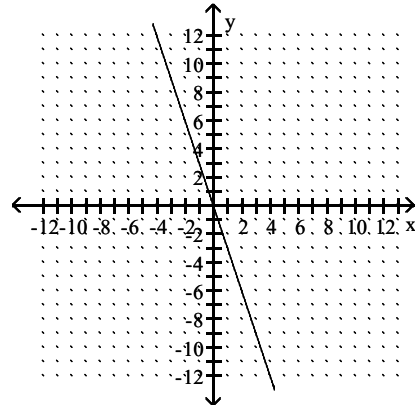

C)

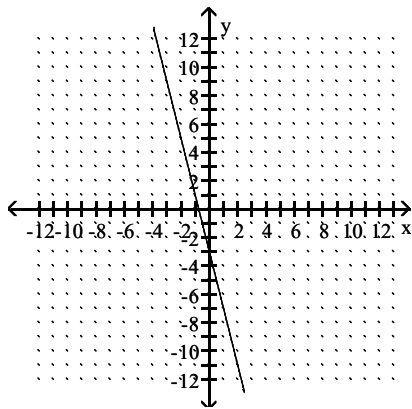

D)

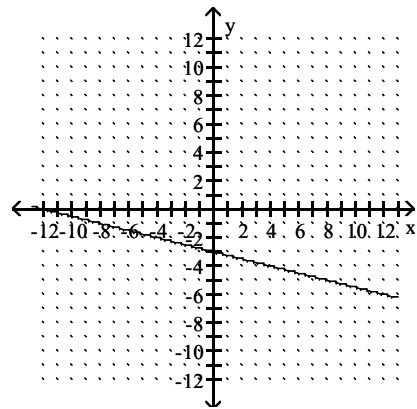

Answer: D

$$269) y - 4 = \frac{7}{6}(x - 3)$$

A)

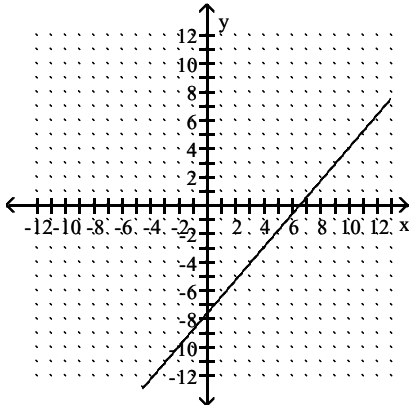

B)

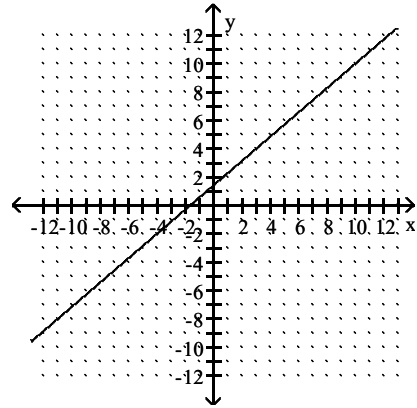

C)

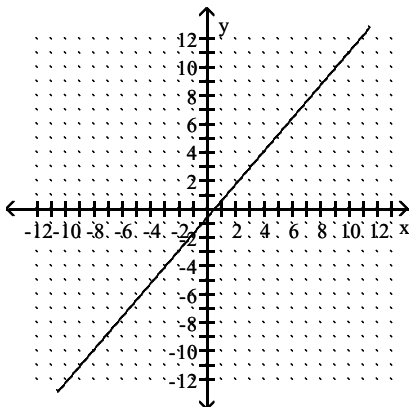

D)

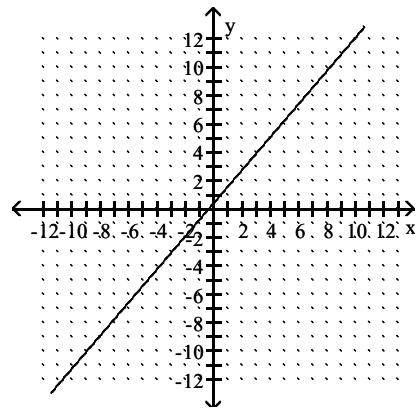

Answer: D

$$270) y + 2 = \frac{8}{3}(x - 4)$$

A)

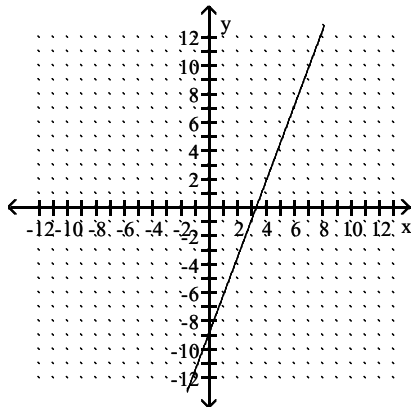

B)

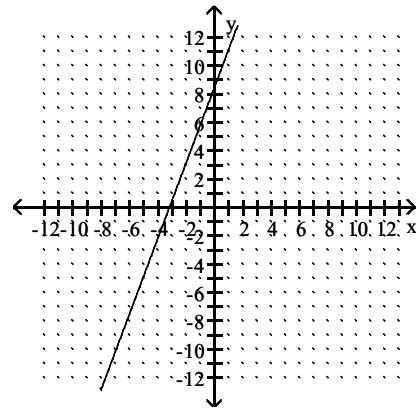

C)

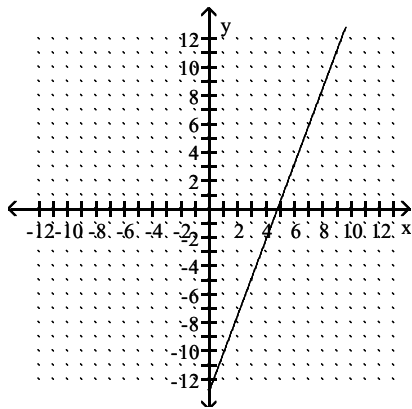

D)

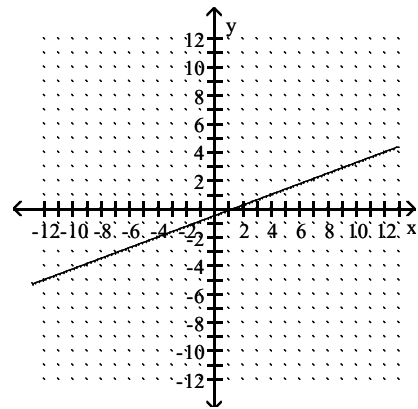

Answer: C

271) $y = -1$

A)

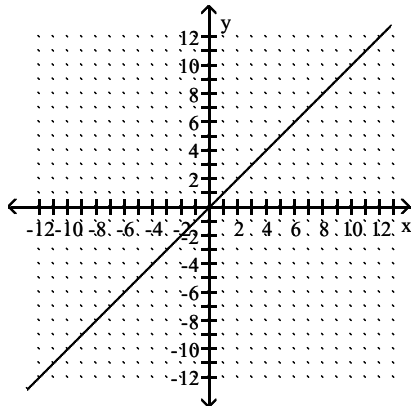

B)

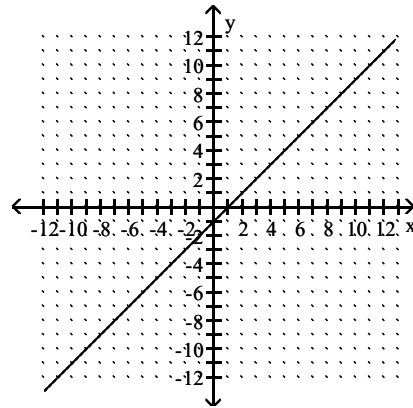

C)

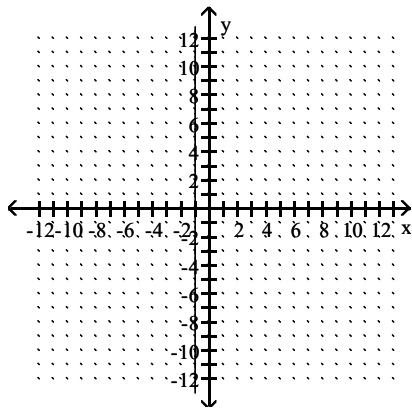

D)

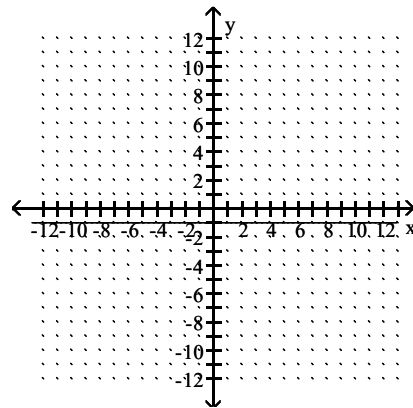

Answer: D

272) $x = -4$

A)

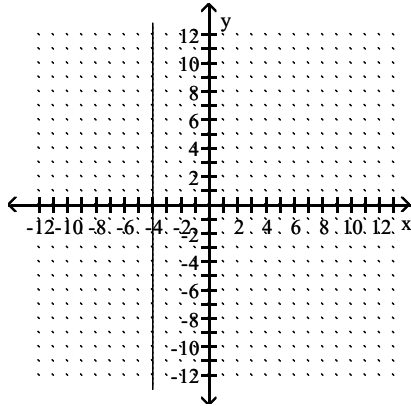

B)

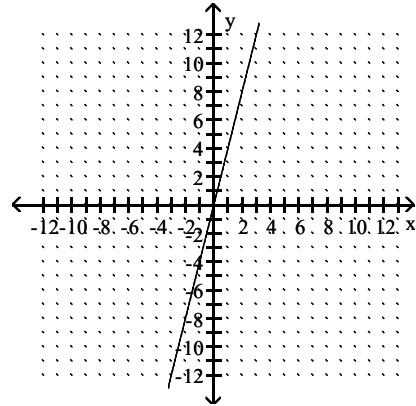

C)

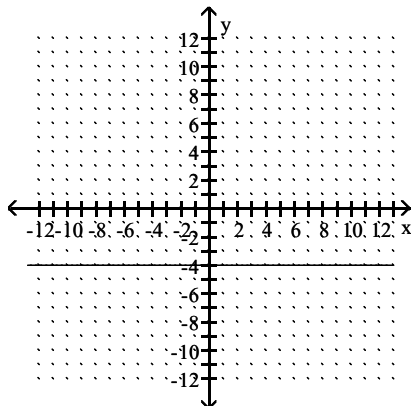

D)

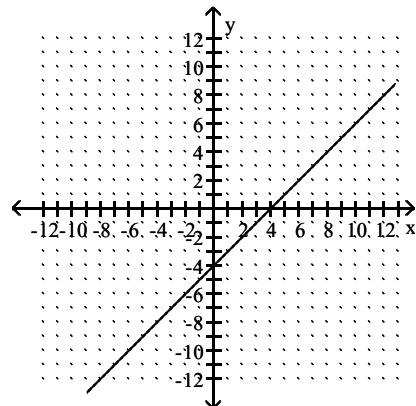

Answer: A

Write an equation for the line described. Give your answer in standard form.

273) through $(0, 5)$, $m = \frac{2}{7}$

A) $7x - 2y = -35$

B) $2x - 7y = 35$

C) $2x - 7y = -35$

D) $2x + 7y = -35$

Answer: C

274) through $(3, 2)$, undefined slope

A) $y = 3$

B) $y = 2$

C) $x = 3$

D) $x = 2$

Answer: C

275) x-intercept $(-3, 0)$, y-intercept $(0, 2)$

A) $2x - 3y = 6$

B) $-2x - 3y = -6$

C) $2x - 3y = -6$

D) $2x + 3y = -6$

Answer: C

Write an equation for the line described. Give your answer in slope-intercept form.

276) $m = 5$, through $(4, -8)$

A) $y = 5x + 27$

B) $y = 6x + 29$

C) $y = 5x - 26$

D) $y = 5x - 28$

Answer: D

277) $m = -5$, through $(-5, 6)$

A) $y = -5x + 26$

B) $y = 5x - 17$

C) $y = -5x - 19$

D) $5x + y = 19$

Answer: C

278) $m = -\frac{3}{4}$, through $(1, -3)$

A) $y = -\frac{3}{4}x + \frac{9}{4}$

B) $y = -\frac{3}{4}x - \frac{9}{4}$

C) $y = \frac{3}{4}x + \frac{9}{4}$

D) $y = -\frac{4}{3}x + 3$

Answer: B

279) horizontal, through $(1, -1)$

A) $y = -1$

B) $y = 1$

C) $x = -1$

D) $x = 1$

Answer: A

280) vertical, through $(-2, 1)$

A) $y = 1$

B) $x = 1$

C) $y = -2$

D) $x = -2$

Answer: D

281) through $(-3, 1)$, $m = 0$

A) $y = 1$

B) $x = 1$

C) $x = -3$

D) $y = -3$

Answer: A

282) through $(7, -7)$ and $(0, -5)$

A) $y = \frac{14}{5}x - 5$

B) $y = \frac{2}{7}x - 5$

C) $y = -\frac{14}{5}x - 5$

D) $y = -\frac{2}{7}x - 5$

Answer: D

283) $m = -3$, $b = 9$

A) $y = -3x + 9$

B) $y = 9x - 3$

C) $y = -3x + 9$

D) $-3x + 9y = 0$

Answer: A

284) $m = \frac{9}{4}$, $b = -3$

A) $\frac{9}{4}x - 3y = 0$

B) $y = -3x + \frac{9}{4}$

C) $y = \frac{9}{4}x - 3$

D) $y = \frac{9}{4}x + 3$

Answer: C

285) slope 0, y-intercept $\left(0, \frac{5}{3}\right)$

A) $y = -\frac{5}{3}x$

B) $x = \frac{5}{3}$

C) $y = \frac{5}{3}x$

D) $y = \frac{5}{3}$

Answer: D

Find the slope and the y-intercept of the line.

286) $6x + 7y = 52$

A) slope: $\frac{6}{7}$; y-intercept: $\left(0, \frac{52}{7}\right)$

B) slope: $-\frac{1}{6}$; y-intercept: $\left(0, \frac{7}{52}\right)$

C) slope: $\frac{1}{6}$; y-intercept: $\left(0, \frac{7}{52}\right)$

D) slope: $-\frac{6}{7}$; y-intercept: $\left(0, \frac{52}{7}\right)$

Answer: D

287) $6x - 8y = -8$

A) slope: $-\frac{4}{3}$; y-intercept: (0, 1)

C) slope: $-\frac{3}{4}$; y-intercept: (0, -1)

Answer: D

B) slope: $\frac{4}{3}$; y-intercept: (0, -1)

D) slope: $\frac{3}{4}$; y-intercept: (0, 1)

288) $y = -6x - 3$

A) slope: -6; y-intercept: (0, -3)

C) slope: 6; y-intercept: (0, -3)

Answer: A

B) slope: -3; y-intercept: (0, 6)

D) slope: -3; y-intercept: (0, -6)

289) $-5y = 4x$

A) slope: 0; y-intercept: $\left(0, -\frac{4}{5}\right)$

C) slope: $-\frac{4}{5}$; y-intercept: (0, 0)

Answer: C

B) slope: $-\frac{5}{4}$; y-intercept: (0, 0)

D) slope: 0; y-intercept: $\left(0, -\frac{5}{4}\right)$

290) $x + 2y = -3$

A) slope: $-\frac{1}{2}$; y-intercept: $\left(0, -\frac{3}{2}\right)$

C) slope: -2; y-intercept: (0, -3)

Answer: A

B) slope: $-\frac{3}{2}$; y-intercept: $\left(0, -\frac{1}{2}\right)$

D) slope: $\frac{1}{2}$; y-intercept: $\left(0, -\frac{3}{2}\right)$

291) $6x - y = -5$

A) slope: 5; y-intercept: (0, 6)

C) slope: 6; y-intercept: (0, 5)

Answer: C

B) slope: 6; y-intercept: (0, -5)

D) slope: $\frac{1}{6}$; y-intercept: (0, -5)

292) $y - 4x + 3 = 0$

A) slope: 3; y-intercept: (0, -4)

C) slope: -3; y-intercept: (0, 4)

Answer: B

B) slope: 4; y-intercept: (0, -3)

D) slope: 4; y-intercept: (0, 3)

The graph of a linear function f is shown. Identify the slope, y -intercept, and x -intercept.

293)

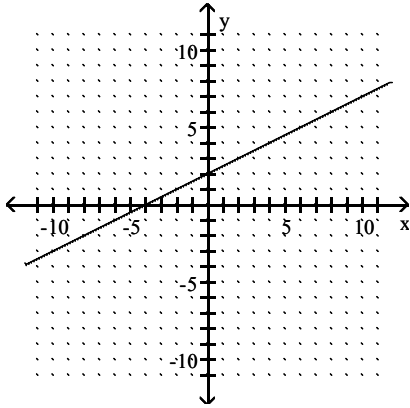

- A) 2; (0, -4), (2, 0) B) $\frac{1}{2}$; (0, -4), (2, 0) C) 2; (0, 2), (-4, 0) D) $\frac{1}{2}$; (0, 2), (-4, 0)

Answer: D

294)

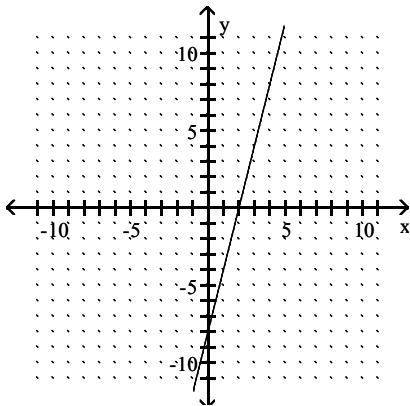

- A) 4; (0, 2), (-8, 0) B) $\frac{1}{4}$; (0, -8), (2, 0) C) 4; (0, -8), (2, 0) D) $\frac{1}{4}$; (0, 2), (-8, 0)

Answer: C

295)

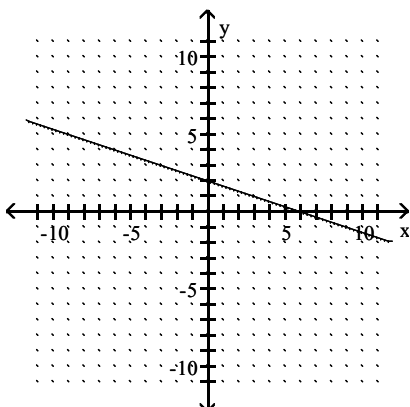

- A) $\frac{1}{3}$; (0, 2), (6, 0) B) -3; (0, 2), (6, 0) C) $-\frac{1}{3}$; (0, 2), (6, 0) D) $-\frac{1}{3}$; (0, 6), (2, 0)

Answer: C

The graph of a linear function f is shown. Write the equation that defines f . Write the equation in slope-intercept form.

296)

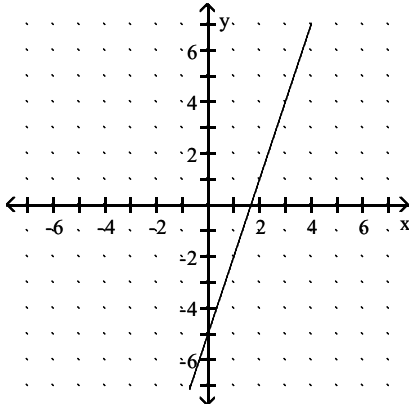

A) $y = -3x + 5$

B) $y = 3x + 5$

C) $y = -3x - 5$

D) $y = 3x - 5$

Answer: D

297)

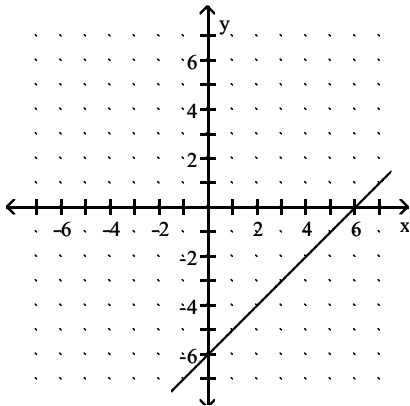

A) $y = -x - 6$

B) $y = x + 6$

C) $y = -x + 6$

D) $y = x - 6$

Answer: D

298)

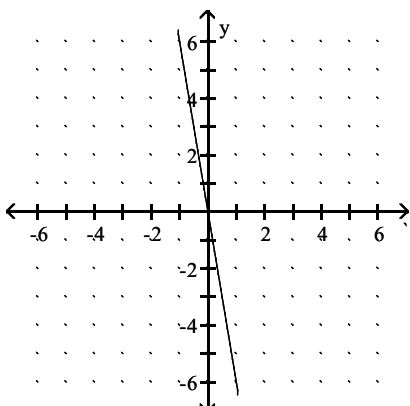

A) $y = \frac{x}{-6}$

B) $y = \frac{x}{6}$

C) $y = 6x$

D) $y = -6x$

Answer: D

299)

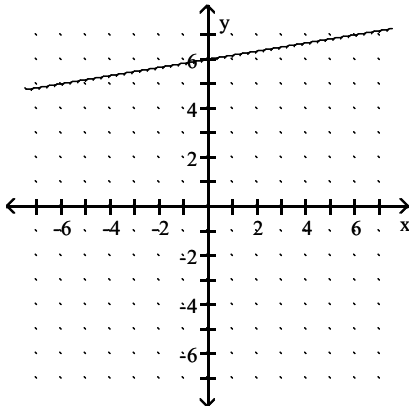

A) $y = \frac{1}{6}x - 6$

B) $y = \frac{1}{6}x + 6$

C) $y = 6x + 6$

D) $y = 6x - 6$

Answer: B

300)

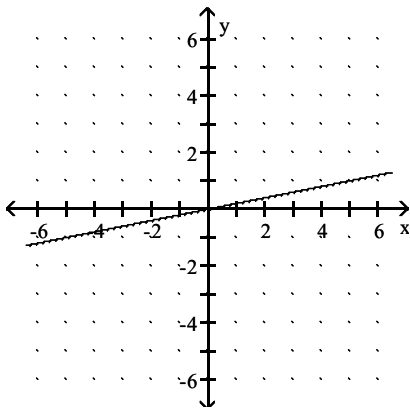

A) $y = -\frac{1}{5}x$

B) $y = \frac{1}{5}x$

C) $y = -5x$

D) $y = 5x$

Answer: B

301)

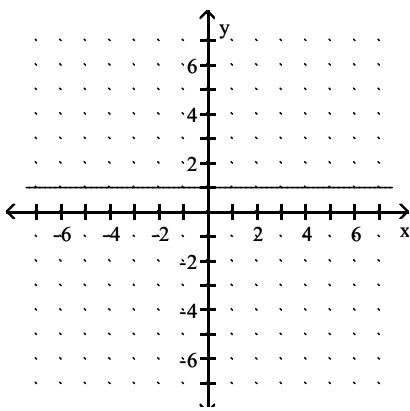

A) $x = 1$

B) $x = -1$

C) $y = -1$

D) $y = 1$

Answer: D

Write an equation for the line described. Write the equation in the form specified.

302) parallel to $y = -3$, through $(4, 9)$

A) $y = -3$

B) $y = 9$

C) $y = -9$

D) $y = 4$

Answer: B

303) parallel to $x = 3$, through $(9, 5)$

A) $x = 5$

B) $y = 3$

C) $y = 5$

D) $x = 9$

Answer: D

304) perpendicular to $y = -6$, through $(1, 3)$

A) $x = 1$

B) $y = 1$

C) $y = 3$

D) $x = 3$

Answer: A

305) perpendicular to $x = -2$, through $(4, 5)$

A) $y = 5$

B) $y = 4$

C) $x = 5$

D) $x = 4$

Answer: A

306) parallel to $y + 5x = 4$, through $(3, 5)$; slope-intercept form

A) $y = -\frac{1}{5}x - 4$

B) $y = -5x - 20$

C) $y = 5x - 20$

D) $y = -5x + 20$

Answer: D

307) perpendicular to $-9x + y = 5$, through $(5, 4)$; slope-intercept form

A) $y = \frac{1}{9}x - \frac{41}{9}$

B) $y = -\frac{1}{9}x - \frac{41}{9}$

C) $y = -9x - 41$

D) $y = -\frac{1}{9}x + \frac{41}{9}$

Answer: D

308) parallel to $9x - 2y = -53$, through $(-5, 7)$; slope-intercept form

A) $y = \frac{2}{9}x + \frac{7}{9}$

B) $y = \frac{9}{2}x + \frac{59}{2}$

C) $y = -\frac{5}{2}x + \frac{53}{2}$

D) $y = -\frac{9}{2}x - \frac{59}{2}$

Answer: B

309) parallel to $4x + 7y = -17$; through $(8, -13)$; standard form

A) $8x + 7y = -17$

B) $7x + 4y = -13$

C) $4x - 7y = -59$

D) $4x + 7y = -59$

Answer: D

310) perpendicular to $-8x + 7y = 8$, through $(-8, 8)$; slope-intercept form

A) $y = -\frac{7}{8}x + 1$

B) $y = \frac{7}{8}x + 1$

C) $y = -\frac{8}{7}x - \frac{8}{7}$

D) $y = -\frac{8}{7}x - \frac{8}{7}$

Answer: A

311) perpendicular to $5x - 9y = -20$, through $(5, -5)$; standard form

A) $9x - 5y = 20$

B) $9x + 5y = 20$

C) $5x + 9y = -20$

D) $5x + 9 = 5$

Answer: B

Solve the problem. Write all linear equations in slope-intercept form.

312) A house was purchased for \$65,000. After 6 years the value of the house was \$119,000. Find a linear equation that models the value of the house after x years.

- A) $y = 9000x + 65,000$ B) $y = 9000x$ C) $y = 6x + 65,000$ D) $y = 119,000$

Answer: A

313) A company can make 10 bridge bulkheads for \$70,800, while 19 bridge bulkheads cost \$75,300. Find a linear equation that models the cost to produce x bridge bulkheads.

- A) $y = 500x - 65,800$ B) $y = x + 4500$ C) $y = 9x + 4500$ D) $y = 500x + 65,800$

Answer: D

314) In a lab experiment 8 grams of acid were produced in 30 minutes and 18 grams in 34 minutes. Find a linear equation that models the number of grams produced in x minutes.

- A) $y = \frac{5}{2}x + 67$ B) $y = \frac{5}{2}x - 67$ C) $y = \frac{2}{5}x - \frac{1}{67}$ D) $y = x + 22$

Answer: B

315) A biologist recorded 8 snakes on 23 acres in one area and 16 snakes on 37 acres in another area. Find a linear equation that models the number of snakes in x acres.

- A) $y = \frac{4}{7}x + \frac{36}{7}$ B) $y = \frac{4}{7}x - \frac{36}{7}$ C) $y = \frac{7}{4}x - \frac{7}{36}$ D) $y = x + 15$

Answer: B

316) With 20.5% commitment, a company can clean up 35% of an acid rain forest. With 23.5% commitment, it can clean up 62% of an acid rain forest. Find a linear equation that models the percent cleanup for x percent commitment.

- A) $y = 9x + 149.5$ B) $y = x + 27$ C) $y = 3x + 27$ D) $y = 9x - 149.5$

Answer: D

317) Suppose that a sales person observes that if an item is priced at \$10 per item then 7 items are sold. If 5 items are sold for \$12 per item then find a linear equation to model the number y of items sold for x dollars per item. Find the slope-intercept form of the equation of the line.

- A) $y = -x - 3$ B) $y = -x + 17$ C) $y = x - 3$ D) $y = x + 17$

Answer: B

318) A driver wants to gauge the fuel efficiency of her vehicle at speeds of 30 mph and above. She notices that traveling at an average speed of 45 mph results in a rating of 38 mpg, whereas at an average speed of 55 mph, her car rates 23 mpg. Find a linear equation to model the gas mileage y for an average speed of x mph. Find the slope-intercept form of the equation of the line.

- A) $y = -\frac{3}{2}x + \frac{59}{2}$ B) $y = \frac{2}{3}x + \frac{211}{2}$ C) $y = \frac{2}{3}x + \frac{59}{2}$ D) $y = -\frac{3}{2}x + \frac{211}{2}$

Answer: D

- 319) The table lists the average annual cost (in dollars) of room and board at public four-year colleges in the city of Bookhaven for selected years.

PUBLIC FOUR-YEAR COLLEGE ROOM AND BOARD

Year	Room and Board (in dollars)
1	1270
2	1545
3	1774.5
4	2044.5
5	2345
6	2625

Determine a linear function f defined by $f(x) = mx + b$ that models the data using (1, 1270) and (6, 2625).

A) $f(x) = 271x + 999$

B) $f(x) = 1270$

C) $f(x) = 2291 - 1021x$

D) $f(x) = 999x + 271$

Answer: A

- 320) The amount of time t it takes a flame to go out in a closed container is a linear function of the volume of the container x . A flame in 656 mL container takes 12 seconds to go out and a flame in a 984 mL container takes 20 seconds. Write a linear function that relates t to x .

A) $t = \frac{1}{41}x - 4$

B) $t = \frac{4}{205}x - \frac{4}{5}$

C) $t = \frac{1}{41}x$

D) $t = 41x - 4$

Answer: A

- 321) By reading a graph on defense spending in the country of Warpeas, you discover that in year 0 the country spent \$42 million on defense and in year 8 spent \$378 million. Write a linear function that relates y (in millions of dollars) to x .

A) $y = 42x + 42$

B) $y = \frac{1}{1}x + 42$

C) $y = \frac{105}{2}x + 42$

D) $y = -42x - 42$

Answer: A

Use a graphing calculator to solve the linear equation.

322) $-9x + 2 + 7x = -2x + 7$

A) $\{-2\}$

B) all real numbers

C) \emptyset

D) $\{5\}$

Answer: C

323) $3(2z - 4) = 5(z + 3)$

A) $\{-3\}$

B) $\{27\}$

C) $\{6\}$

D) $\{3\}$

Answer: B

324) $10y = 7y + 8 + 2y$

A) $\{-80\}$

B) $\{80\}$

C) $\{8\}$

D) $\{-8\}$

Answer: C

325) $-8x + 7(3x - 4) = -9 - 6x$

A) $\{-1\}$

B) $\{0\}$

C) $\{2\}$

D) $\{1\}$

Answer: D

326) $(5x - 4) - 1 = 6(x + 8)$

A) $\{13\}$

B) $\{53\}$

C) $\{51\}$

D) $\{-53\}$

Answer: D

327) Rewrite the equation so that one side is 0, then replace 0 with y. The graph of the equation for y is shown. Use the graph to determine the solution of the equation.

$$3x + 1 + x = 2x - 3$$

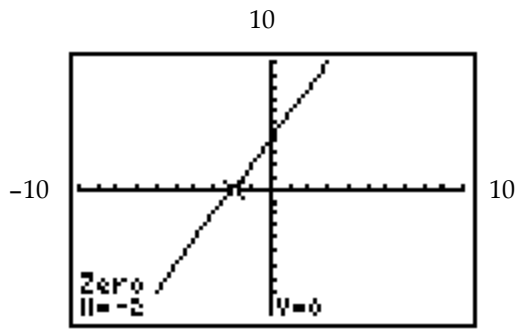

- A) $y = 4x + 2; -2$ B) $y = 2x + 4; 0$ C) $y = 2x + 4; -2$ D) $y = 4x + 2; 0$
- Answer: C

328) The graph of y_1 is shown in the standard viewing window. Which is the only choice that could possibly be the solution of the equation $y_1 = 0$?

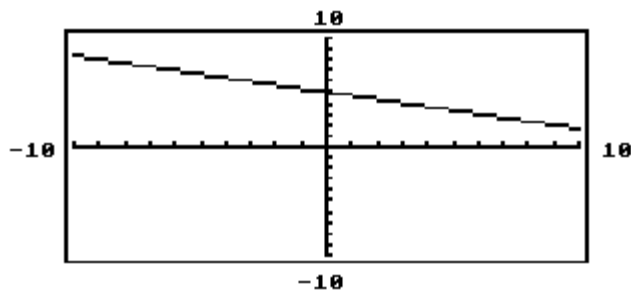

- A) -5 B) 5 C) $\frac{16}{3}$ D) 15

Answer: D

329) The graph of y_1 is shown in the standard viewing window. Which is the only choice that could possibly be the solution of the equation $y_1 = 0$?

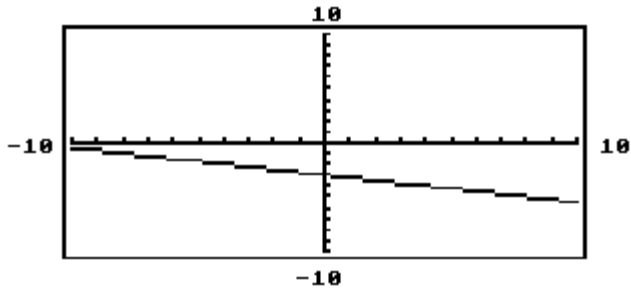

$-12, -\frac{13}{4}, 3, 12$

A) $-\frac{13}{4}$

B) 12

C) 3

D) -12

Answer: D

330) The graph of y_1 is shown in the standard viewing window. Which is the only choice that could possibly be the solution of the equation $y_1 = 0$?

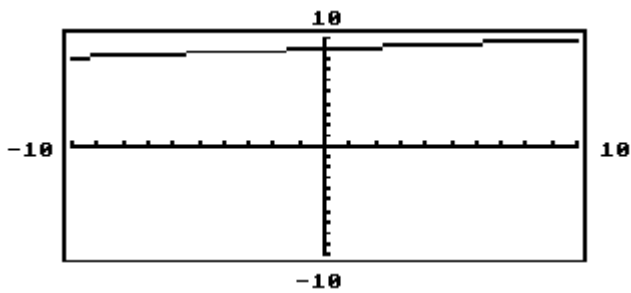

$-90, -\frac{91}{10}, \frac{91}{10}, 85$

A) -90

B) $\frac{91}{10}$

C) $-\frac{91}{10}$

D) 85

Answer: A

331) The graph of y_1 is shown in the standard viewing window. Which is the only choice that could possibly be the solution of the equation $y_1 = 0$?

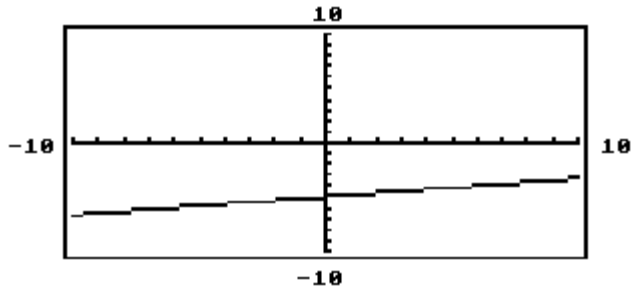

$-30, -\frac{31}{6}, \frac{31}{6}, 30$

A) 30

B) -30

C) $-\frac{31}{6}$

D) $\frac{31}{6}$

Answer: A

332) The graph of y_1 is shown in the standard viewing window. Which is the only choice that could possibly be the solution of the equation $y_1 = 0$?

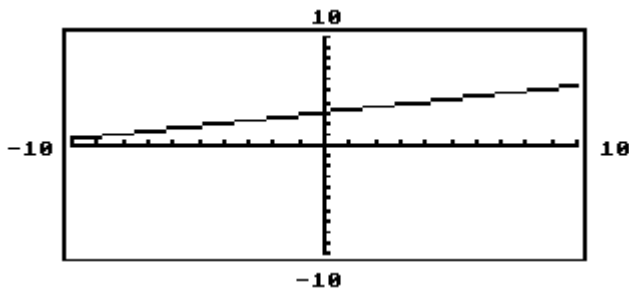

$-12, -7, -\frac{13}{4}, 12$

A) 12

B) -12

C) -7

D) $-\frac{13}{4}$

Answer: B

Determine whether the three points are collinear.

333) $(16, -1), (7, 5), (25, -7)$

A) Yes

B) No

Answer: A

334) $(5, 11), (-3, 6), (10, 19)$

A) Yes

B) No

Answer: B

335) $(-4, -9), (3, 5), (9, 17)$

A) Yes

B) No

Answer: A

336) $(9, -5), (-5, 8), (3, -1)$

A) Yes

B) No

Answer: B

Refer to the following graphs to determine an appropriate response.

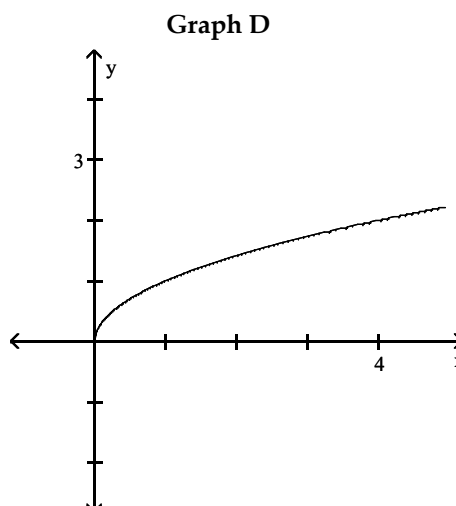
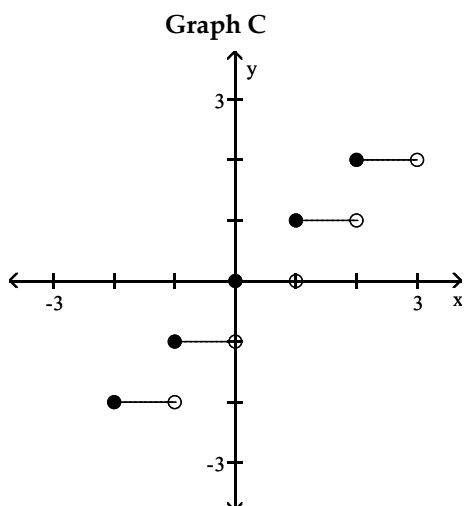
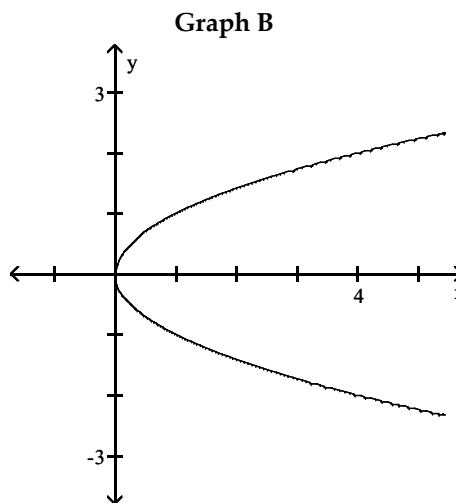
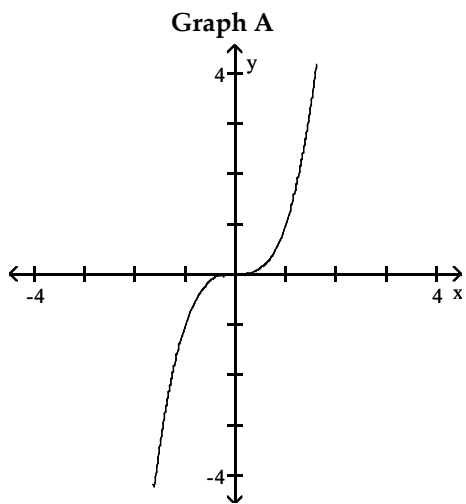

337) Which one is the graph of $y = \sqrt{x}$? What is its domain?

A) graph B; $[0, \infty)$

B) graph D; $[0, \infty)$

C) graph C; $\{-2, -1, 0, 1, 2\}$

D) graph A; $(-\infty, \infty)$

Answer: B

338) Which one is the graph of $y = \lceil x \rceil$? What is the value of y when $x = -1.5$?

A) graph A; 2.25

B) graph C; -2

C) graph D; -2

D) graph B; 2.25

Answer: B

339) Which one is the graph of $y = x^3$? What is its range?

A) graph D; $[0, \infty)$

B) graph C; $[-2, 2]$

C) graph B; $(-\infty, \infty)$

D) graph A; $(-\infty, \infty)$

Answer: D

340) Which is not the graph of a function? What is its equation?

A) graph A; $y = x$

B) graph C; $y = \sqrt{x}$

C) graph B; $x = y^2$

D) graph D; $y = \lfloor x \rfloor$

Answer: C

341) Which one is discontinuous over its domain? What is its range?

A) graph C; $(-\infty, \infty)$

B) graph C; $\{-2, -1, 0, 1, 2\}$

C) graph B; $[0, \infty)$

D) graph B; $(-\infty, \infty)$

Answer: B

342) Which graphs of functions increase over the whole of their domain?

A) graphs C and D

B) graphs A and D

C) graphs A and B

D) graph D

Answer: B

Determine the intervals of the domain over which the function is continuous.

343) $P(-1, -3)$

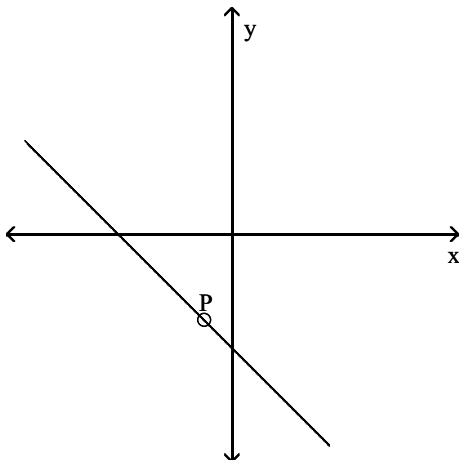

A) $(-\infty, -3) \cup (-3, \infty)$

B) $(-\infty, -1) \cup (-1, \infty)$

C) $(-\infty, -1] \cup [-1, \infty)$

D) $(-\infty, \infty)$

Answer: B

344)

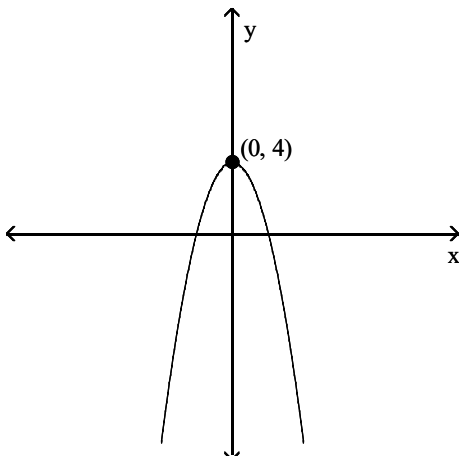

A) $[0, \infty)$

B) $(4, \infty)$

C) $(-\infty, 4]$

D) $(-\infty, \infty)$

Answer: D

345)

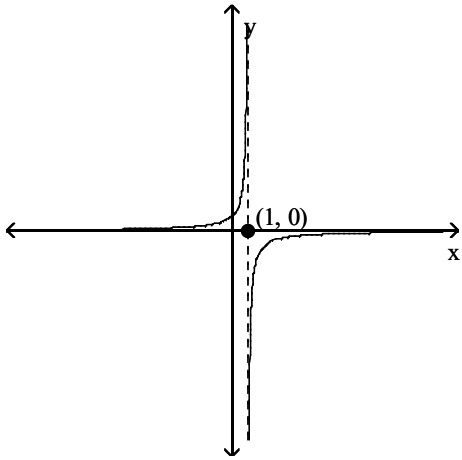

A) $(-\infty, \infty)$

B) $(-\infty, 0) \cup (0, \infty)$

C) $(-\infty, 1) \cup (1, \infty)$

D) $(-\infty, 1] \cup [1, \infty)$

Answer: C

346)

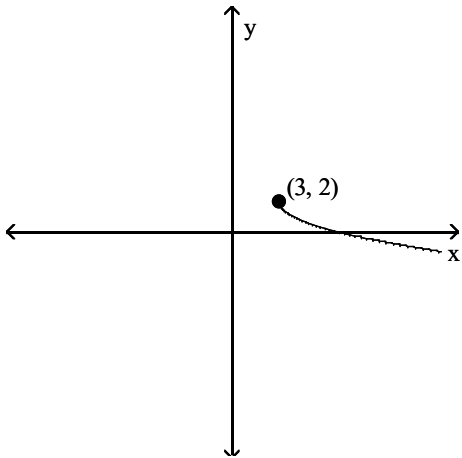

A) $(-\infty, 3) \cup (3, \infty)$

B) $[2, \infty)$

C) $[3, \infty)$

D) $(-\infty, \infty)$

Answer: C

347)

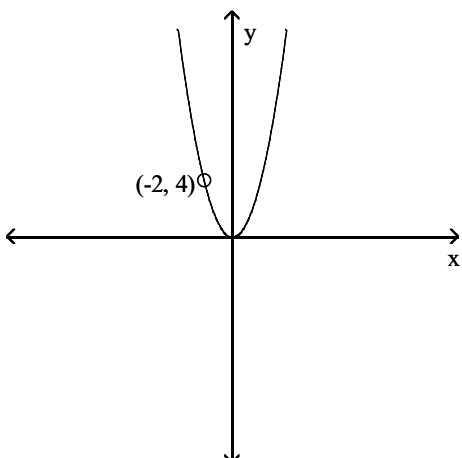

A) $(-\infty, \infty)$

B) $(-\infty, 4) \cup (4, \infty)$

C) $(-\infty, -2) \cup (-2, \infty)$

D) $[0, \infty]$

Answer: C

348)

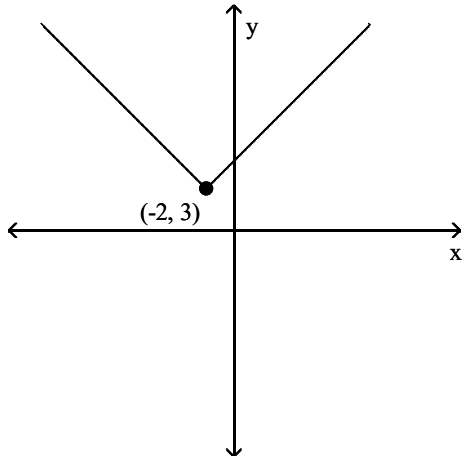

A) $(-\infty, \infty)$

B) $[-2, \infty)$

C) $(-\infty, -2) \cup (-2, \infty)$

D) $(-\infty, 3) \cup (3, \infty)$

Answer: A

Find the requested value.

349) $f(-6)$ for $f(x) = \begin{cases} 7x, & \text{if } x \leq -1 \\ x - 9, & \text{if } x > -1 \end{cases}$

A) -3

B) -15

C) -42

D) 42

Answer: C

350) $f(8)$ for $f(x) = \begin{cases} 4x + 6, & \text{if } x \leq 0 \\ 2 - 7x, & \text{if } 0 < x < 7 \\ x, & \text{if } x \geq 7 \end{cases}$

A) 7

B) 8

C) 38

D) -54

Answer: B

351) $f(8)$ for $f(x) = \begin{cases} 8x + 1, & \text{if } x < 1 \\ 8x, & \text{if } 8 \leq x \leq 11 \\ 8 - 5x, & \text{if } x > 11 \end{cases}$

A) 56

B) 64

C) -32

D) 9

Answer: B

352) $f(-8)$ for $f(x) = \begin{cases} 6x + 1, & \text{if } x < 8 \\ 8x, & \text{if } 8 \leq x \leq 12 \\ 8 - 7x, & \text{if } x > 12 \end{cases}$

A) -64

B) 64

C) -47

D) 49

Answer: C

Graph the function.

$$353) f(x) = \begin{cases} -3, & \text{if } x \geq 1 \\ -5 - x, & \text{if } x < 1 \end{cases}$$

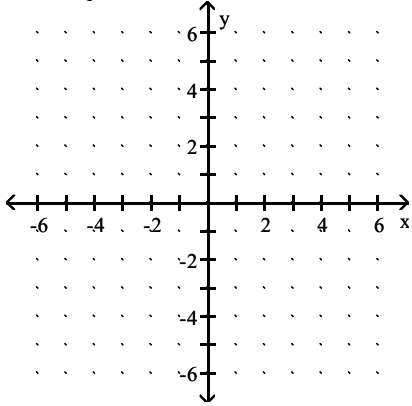

A)

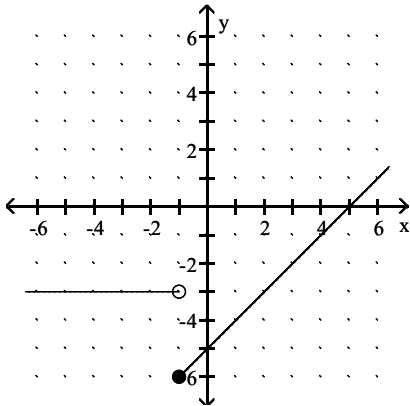

C)

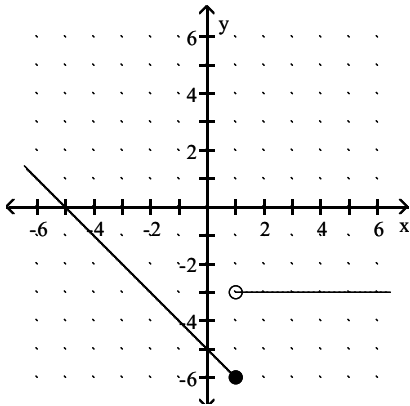

B)

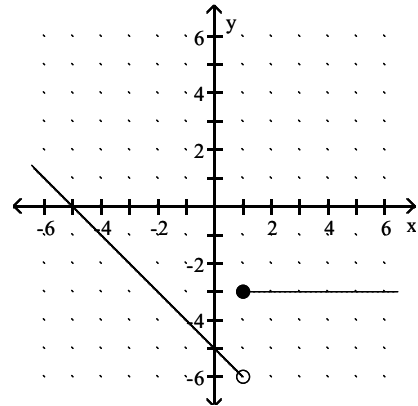

D)

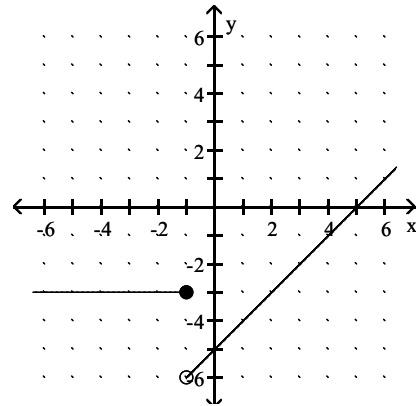

Answer: B

$$354) f(x) = \begin{cases} 2, & \text{if } x > -5 \\ -2, & \text{if } x \leq -5 \end{cases}$$

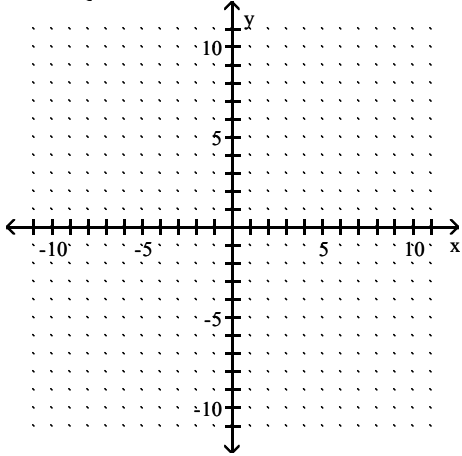

A)

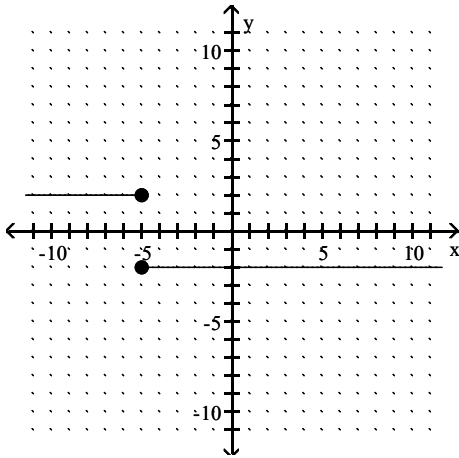

C)

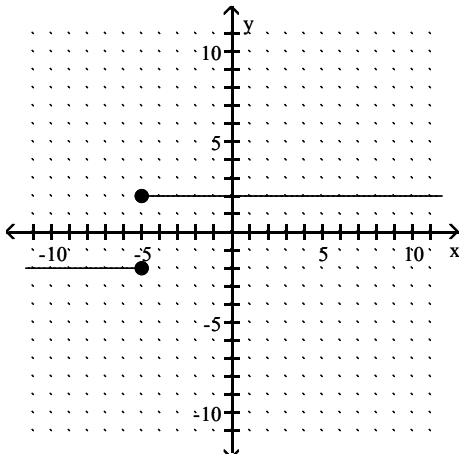

B)

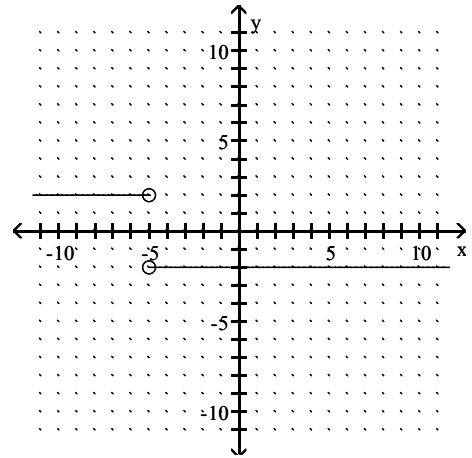

D)

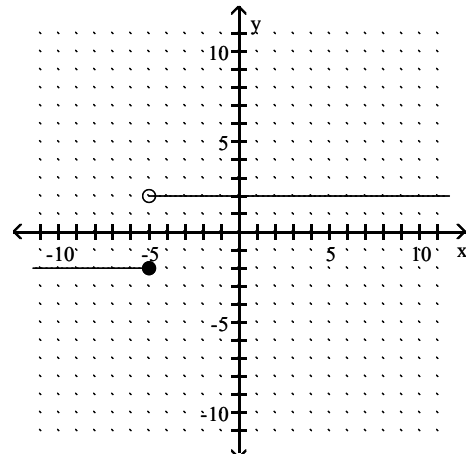

Answer: D

$$355) f(x) = \begin{cases} x + 5, & \text{if } x > 0 \\ -4, & \text{if } x \leq 0 \end{cases}$$

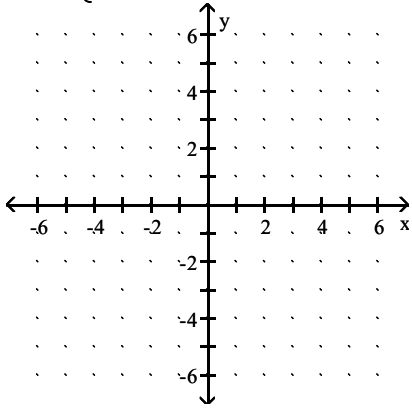

A)

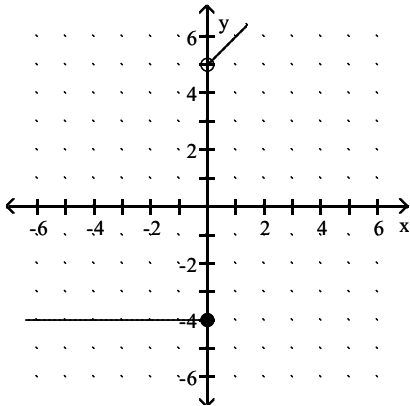

C)

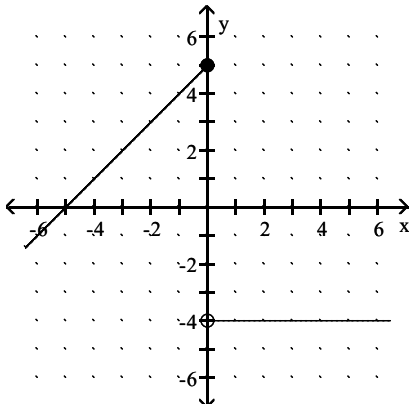

Answer: A

B)

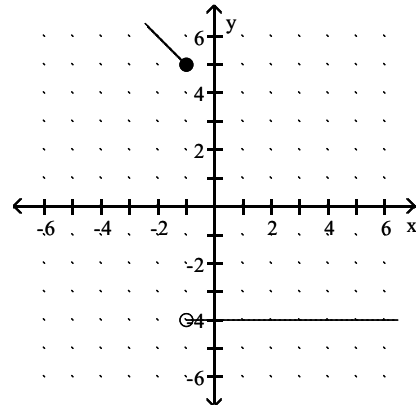

D)

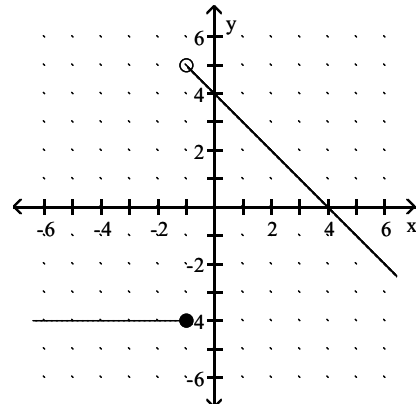

$$356) f(x) = \begin{cases} 9x + 10, & \text{if } x < 0 \\ 2x^2 - 1 & \text{if } x \geq 0 \end{cases}$$

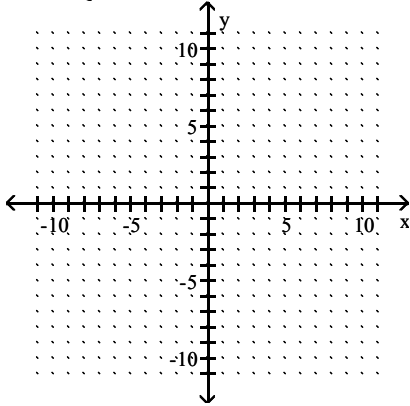

A)

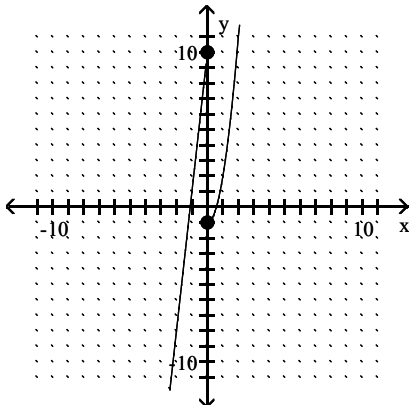

C)

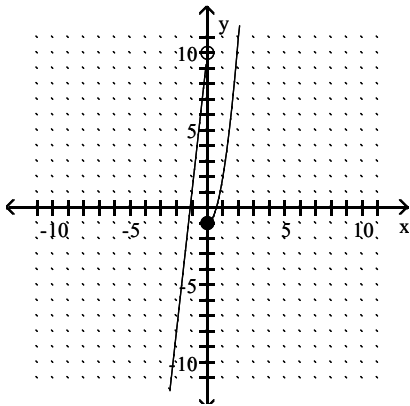

B)

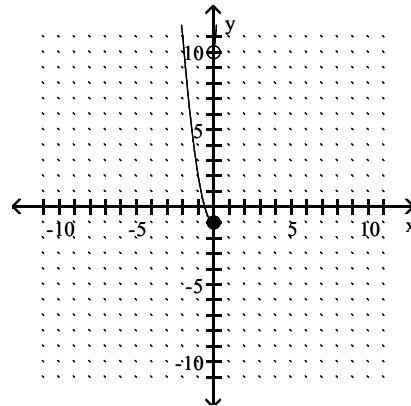

D)

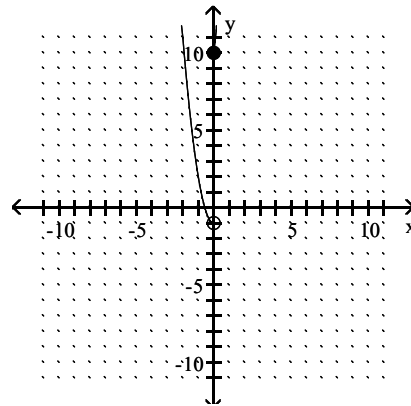

Answer: C

$$357) f(x) = \begin{cases} x^2 - 4, & \text{if } x < -1 \\ 0, & \text{if } -1 \leq x \leq 1 \\ x^2 + 4, & \text{if } x > 1 \end{cases}$$

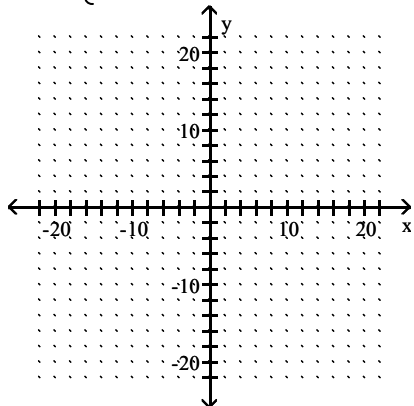

A)

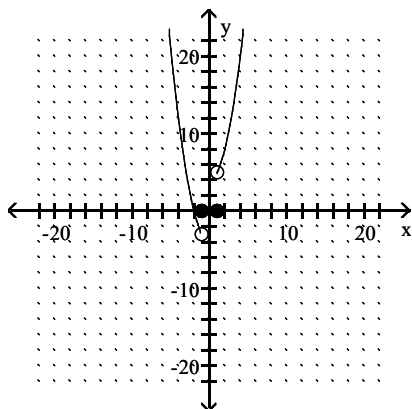

C)

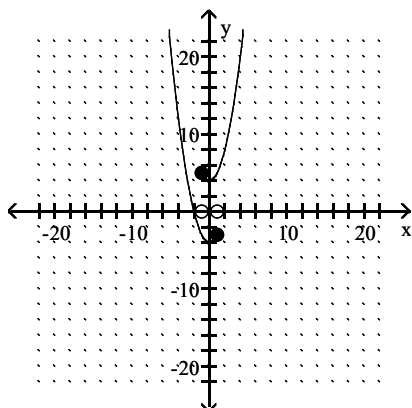

B)

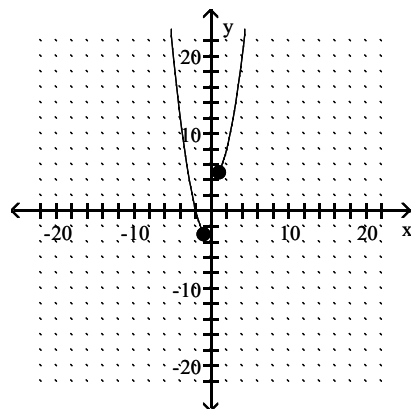

D)

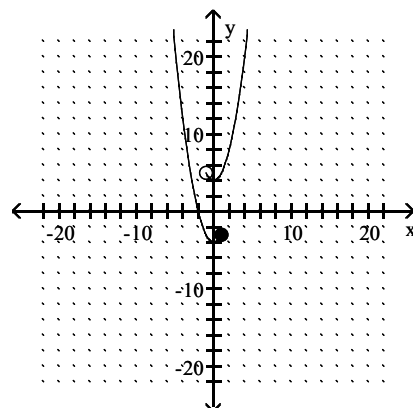

Answer: A

$$358) f(x) = \begin{cases} 3x^2, & \text{if } x \leq -1 \\ 3, & \text{if } -1 < x < 1 \\ 3x + 1, & \text{if } x \geq 1 \end{cases}$$

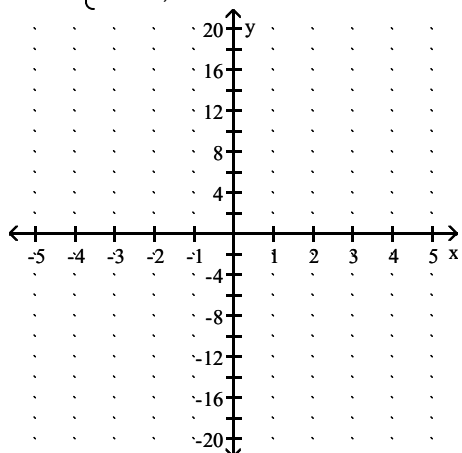

A)

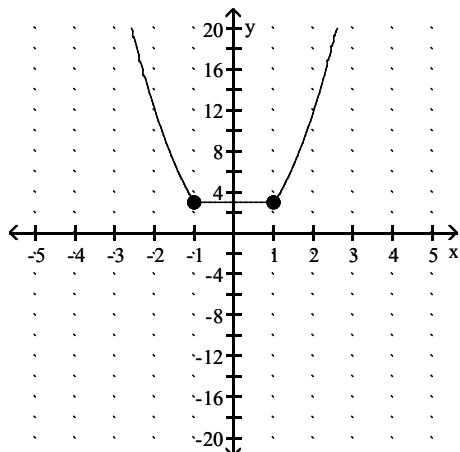

B)

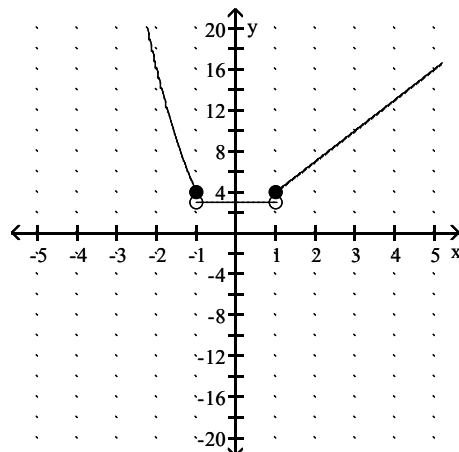

C)

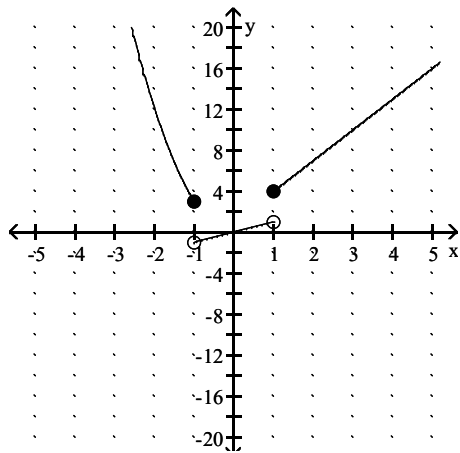

D)

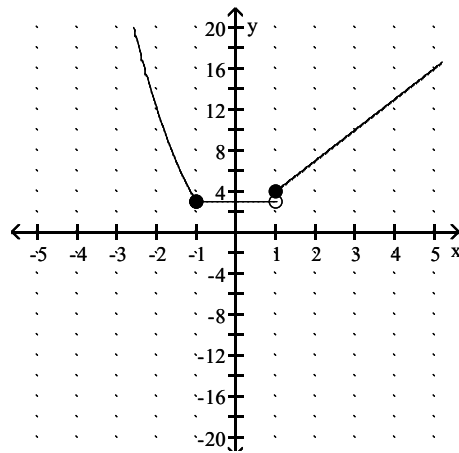

Answer: D

Give a rule for the piecewise-defined function. Then give the domain and range.

359)

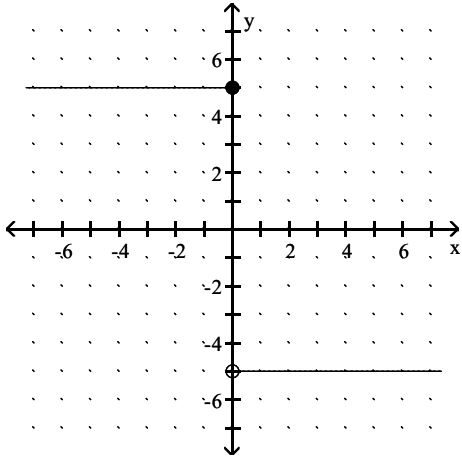

A) $f(x) = \begin{cases} 5 & \text{if } x < 0 \\ -5 & \text{if } x \geq 0 \end{cases}$; Domain: $(-\infty, \infty)$, Range: $\{-5, 5\}$

B) $f(x) = \begin{cases} 5 & \text{if } x \leq 0 \\ -5 & \text{if } x > 0 \end{cases}$; Domain: $(-\infty, \infty)$, Range: $\{-5, 5\}$

C) $f(x) = \begin{cases} -5 & \text{if } x \leq 0 \\ 5 & \text{if } x > 0 \end{cases}$; Domain: $\{-5, 5\}$, Range: $(-\infty, \infty)$

D) $f(x) = \begin{cases} 5x & \text{if } x \leq 0 \\ -5x & \text{if } x > 0 \end{cases}$; Domain: $\{-5, 5\}$, Range: $(-\infty, \infty)$

Answer: B

360)

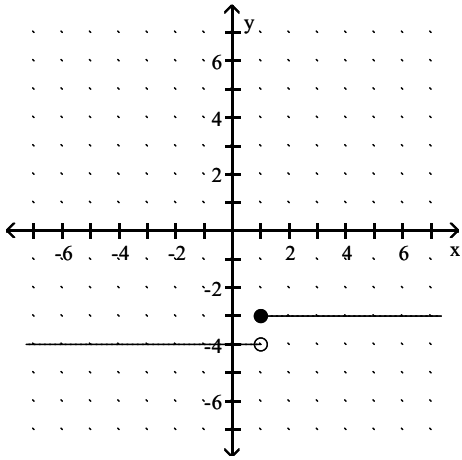

A) $f(x) = \begin{cases} -4 & \text{if } x \leq 1 \\ -3 & \text{if } x > 1 \end{cases}$; Domain: $\{-4, -3\}$, Range: $(-\infty, \infty)$

B) $f(x) = \begin{cases} -4 & \text{if } x \leq 1 \\ -3 & \text{if } x > 1 \end{cases}$; Domain: $(-\infty, \infty)$, Range: $\{-4, -3\}$

C) $f(x) = \begin{cases} -4 & \text{if } x < 1 \\ -3 & \text{if } x \geq 1 \end{cases}$; Domain: $(-\infty, \infty)$, Range: $\{-4, -3\}$

D) $f(x) = \begin{cases} -4 & \text{if } x < 1 \\ -3 & \text{if } x \geq 1 \end{cases}$; Domain: $\{-4, -3\}$, Range: $(-\infty, \infty)$

Answer: C

361)

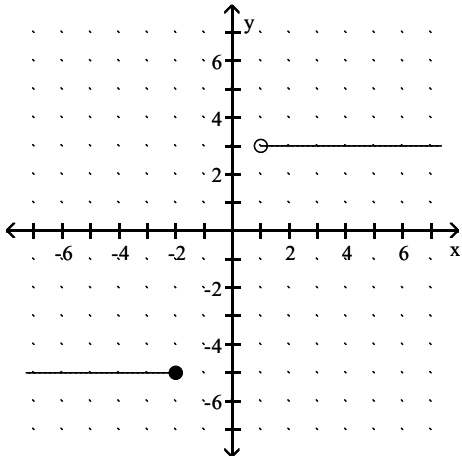

A) $f(x) = \begin{cases} -5 & \text{if } x \leq -2 \\ 3 & \text{if } x > 1 \end{cases}$; Domain: $(-\infty, -2] \cup (1, \infty)$, Range: $\{-5, 3\}$

B) $f(x) = \begin{cases} -5 & \text{if } x < -2 \\ 3 & \text{if } x \geq 1 \end{cases}$; Domain: $(-\infty, -2) \cup [1, \infty)$, Range: $\{-5, 3\}$

C) $f(x) = \begin{cases} -5 & \text{if } x \leq -2 \\ 3 & \text{if } x > 1 \end{cases}$; Domain: $\{-5, 3\}$, Range: $(-\infty, -2] \cup (1, \infty)$

D) $f(x) = \begin{cases} -5 & \text{if } x < -2 \\ 3 & \text{if } x \geq 1 \end{cases}$; Domain: $\{-5, 3\}$, Range: $(-\infty, -2) \cup [1, \infty)$

Answer: A

362)

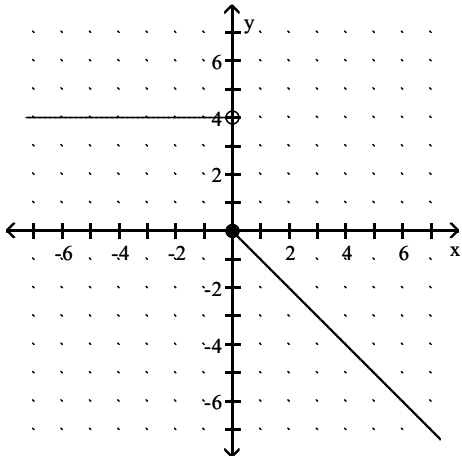

A) $f(x) = \begin{cases} 4 & \text{if } x < 0 \\ -4x & \text{if } x \geq 0 \end{cases}$; Domain: $(-\infty, 0) \cup \{4\}$, Range: $(-\infty, \infty)$

B) $f(x) = \begin{cases} 4 & \text{if } x < 0 \\ -x & \text{if } x \geq 0 \end{cases}$; Domain: $(-\infty, \infty)$, Range: $(-\infty, 0] \cup \{4\}$

C) $f(x) = \begin{cases} 4 & \text{if } x \leq 0 \\ -x & \text{if } x > 0 \end{cases}$; Domain: $(-\infty, \infty)$, Range: $(-\infty, 0) \cup \{4\}$

D) $f(x) = \begin{cases} 4 & \text{if } x < 0 \\ x & \text{if } x \geq 0 \end{cases}$; Domain: $(-\infty, 0] \cup (4, \infty)$, Range: $(-\infty, \infty)$

Answer: B

363)

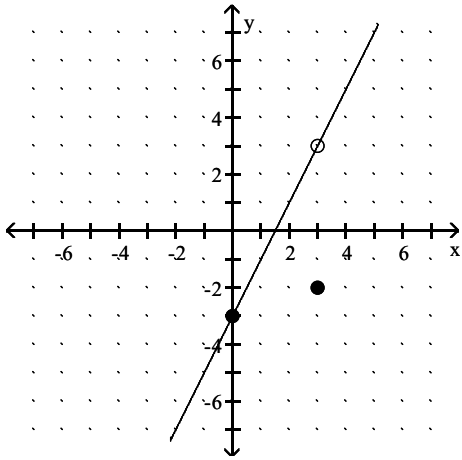

A) $f(x) = \begin{cases} x - 3 & \text{if } x \neq 3 \\ -2 & \text{if } x = 3 \end{cases}$; Domain: $(-\infty, \infty)$, Range: $(-\infty, 3) \cup [3, \infty)$

B) $f(x) = \begin{cases} 2x - 3 & \text{if } x \neq 3 \\ -3 & \text{if } x = 3 \end{cases}$; Domain: $(-\infty, 3] \cup [3, \infty)$, Range: $(-\infty, \infty)$

C) $f(x) = \begin{cases} 2x - 3 & \text{if } x \neq 3 \\ -2 & \text{if } x = 3 \end{cases}$; Domain: $(-\infty, \infty)$, Range: $(-\infty, 3) \cup (3, \infty)$

D) $f(x) = \begin{cases} 2x - 3 & \text{if } x < 3 \\ 2x + 3 & \text{if } x \geq 3 \end{cases}$; Domain: $(-\infty, 3) \cup (3, \infty)$, Range: $(-\infty, \infty)$

Answer: C

364)

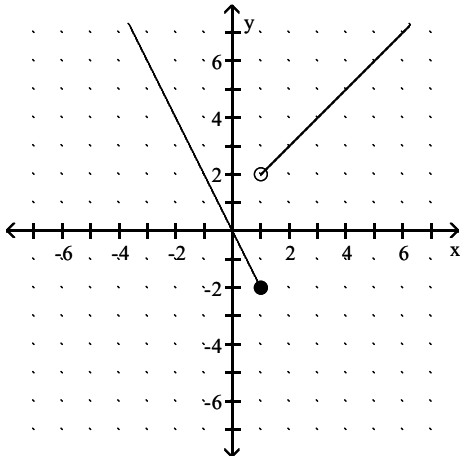

A) $f(x) = \begin{cases} -x & \text{if } x \leq 1 \\ 2x + 1 & \text{if } x > 1 \end{cases}$; Domain: $(-\infty, \infty)$, Range: $(-\infty, 2) \cup (2, \infty)$

B) $f(x) = \begin{cases} -2x & \text{if } x \leq 1 \\ x + 2 & \text{if } x > 1 \end{cases}$; Domain: $(-\infty, 2) \cup (2, \infty)$, Range: $(-\infty, \infty)$

C) $f(x) = \begin{cases} -2x & \text{if } x \leq 1 \\ x + 1 & \text{if } x > 1 \end{cases}$; Domain: $(-\infty, \infty)$, Range: $(-\infty, \infty)$

D) $f(x) = \begin{cases} 2x & \text{if } x \leq 1 \\ x + 1 & \text{if } x > 1 \end{cases}$; Domain: $(-\infty, \infty)$, Range: $(-\infty, \infty)$

Answer: C

365)

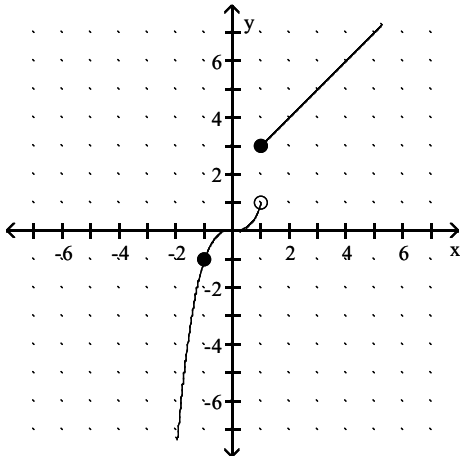

A) $f(x) = \begin{cases} x^3 & \text{if } x < 1 \\ x + 2 & \text{if } x \geq 1 \end{cases}$; Domain: $(-\infty, \infty)$, Range: $(-\infty, 1) \cup [3, \infty)$

B) $f(x) = \begin{cases} -x^3 & \text{if } x < 1 \\ x - 2 & \text{if } x \geq 1 \end{cases}$; Domain: $(-\infty, 1) \cup [3, \infty)$, Range: $(-\infty, \infty)$

C) $f(x) = \begin{cases} x^3 & \text{if } x < 1 \\ x - 2 & \text{if } x \geq 1 \end{cases}$; Domain: $(-\infty, 1) \cup [3, \infty)$, Range: $(-\infty, \infty)$

D) $f(x) = \begin{cases} \sqrt[3]{x} & \text{if } x < 1 \\ x + 2 & \text{if } x \geq 1 \end{cases}$; Domain: $(-\infty, \infty)$, Range: $(-\infty, 1) \cup [3, \infty)$

Answer: A

Graph the function.

366) $f(x) = \lfloor \lfloor x \rfloor \rfloor + 1$

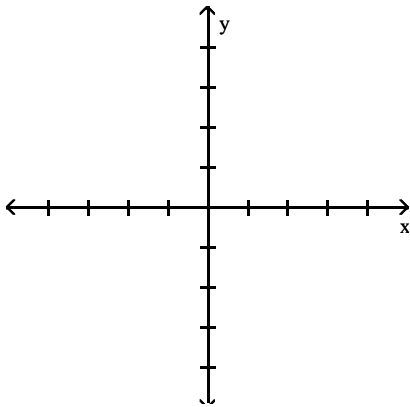

A)

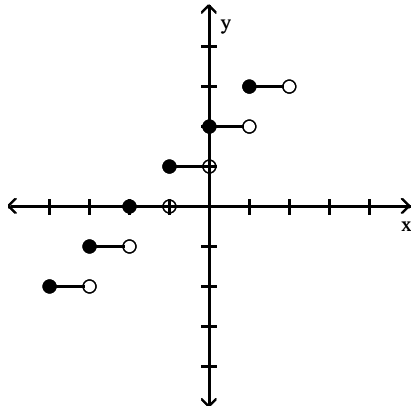

B)

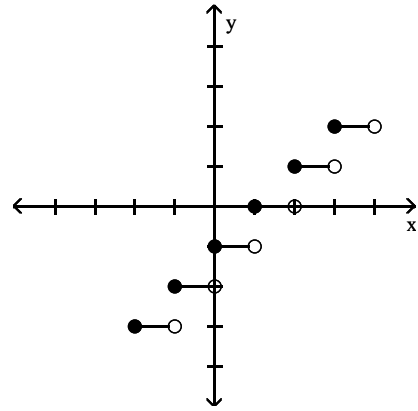

C)

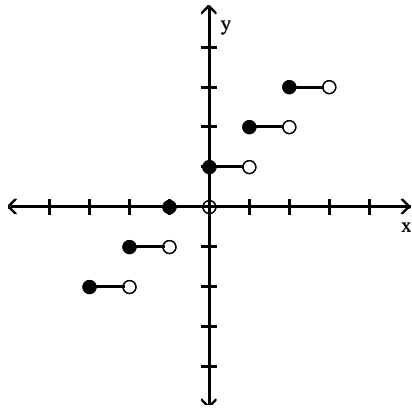

D)

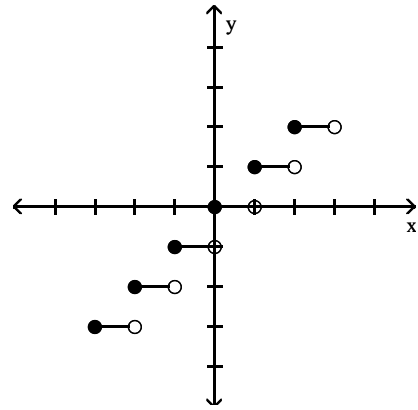

Answer: C

367) $f(x) = \lceil \lfloor x + 1 \rfloor \rceil$

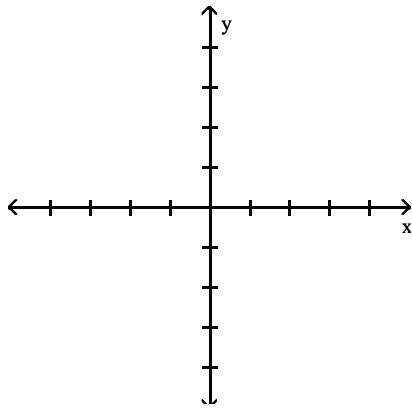

A)

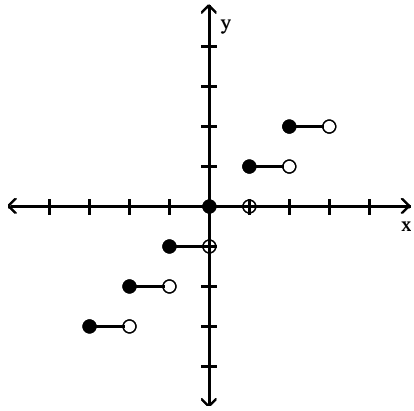

B)

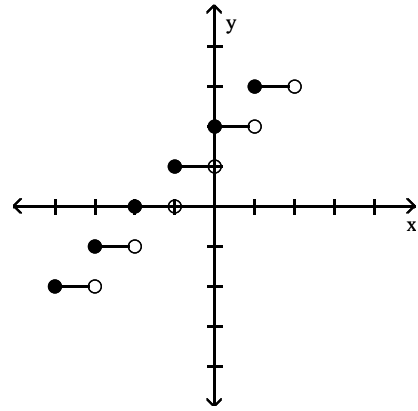

C)

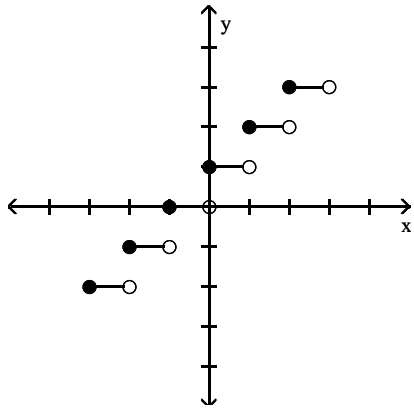

D)

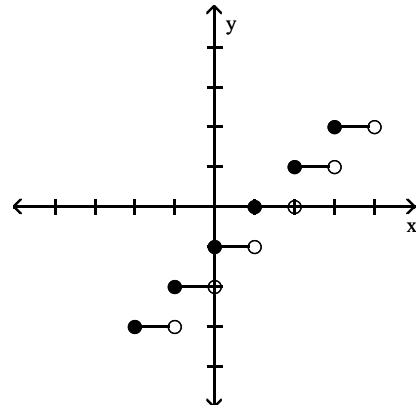

Answer: C

368) $f(x) = \lceil \lceil x \rceil \rceil - 1$

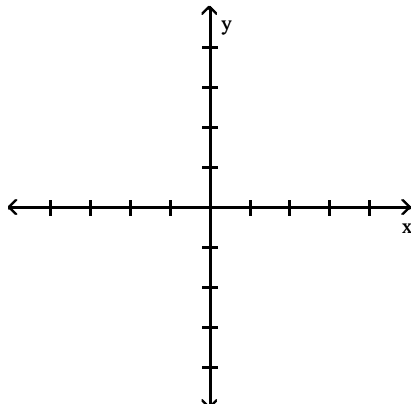

A)

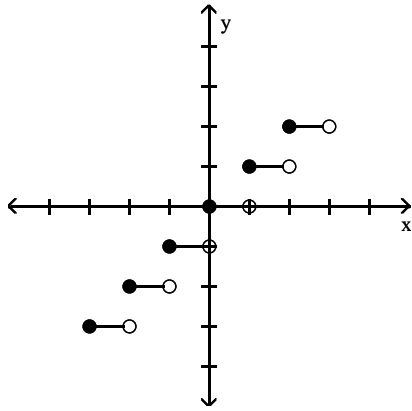

B)

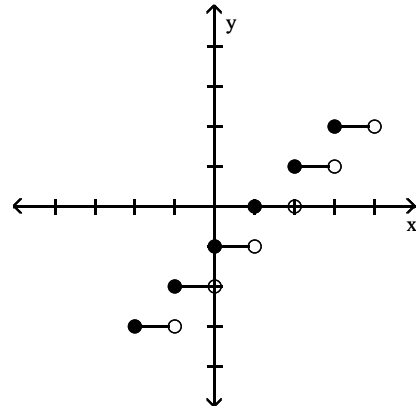

C)

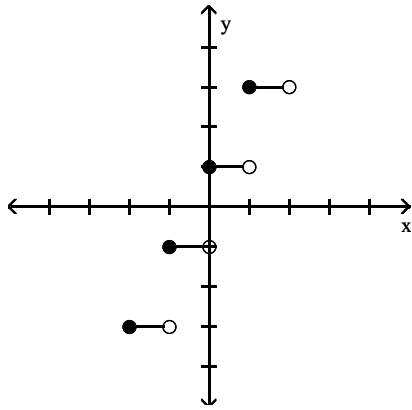

D)

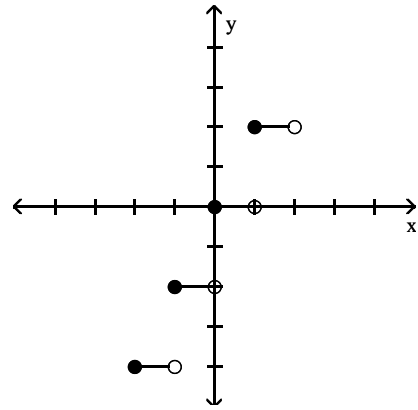

Answer: B

369) $f(x) = \lceil \lceil x - 1 \rceil \rceil$

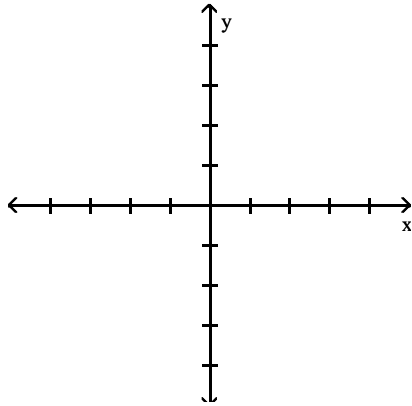

A)

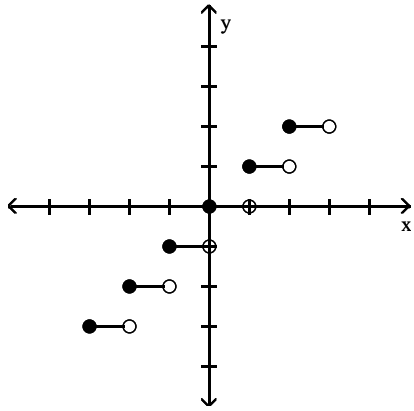

B)

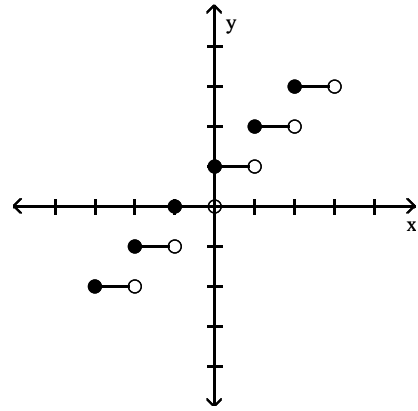

C)

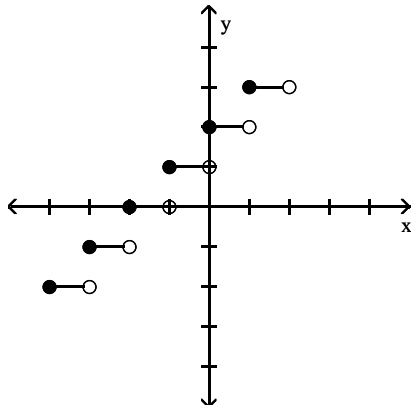

D)

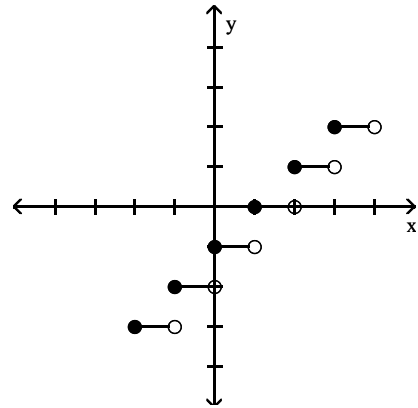

Answer: D

370) $f(x) = 2\lceil x \rceil$

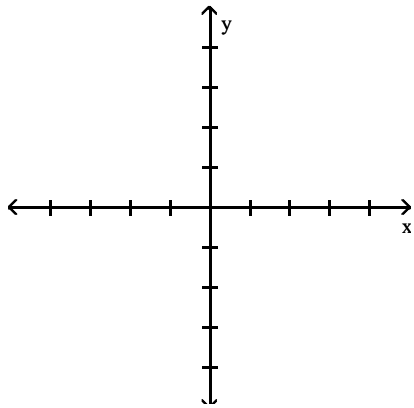

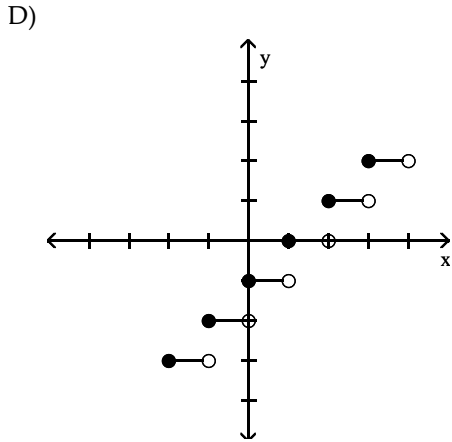
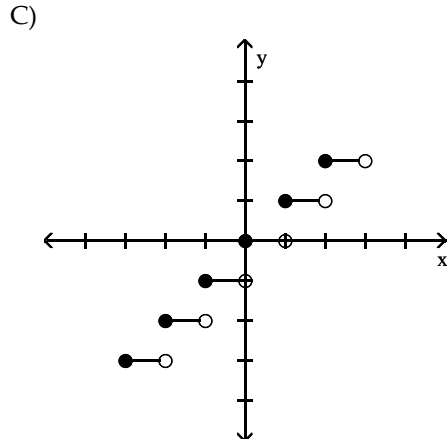
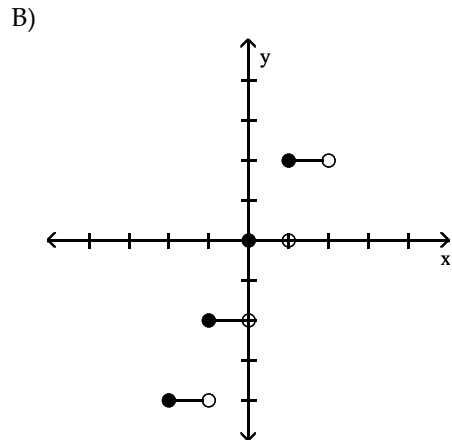
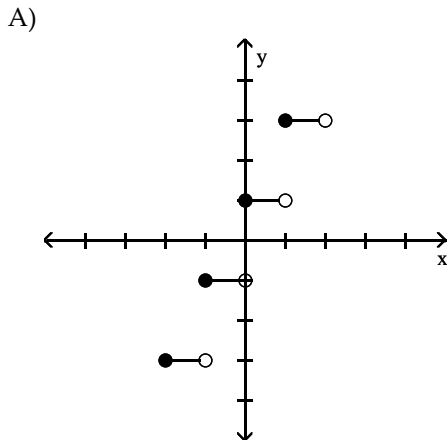

Answer: B

Solve the problem.

371) Employees of a publishing company received an increase in salary of 3% plus a bonus of \$1100. Let $S(x)$ represent the new salary in terms of the previous salary x . Find the value of $S(13,000)$.

- A) \$18,000 B) \$11,553 C) \$14,100 D) \$14,490

Answer: D

372) Assume it costs 25 cents to mail a letter weighing one ounce or less, and then 20 cents for each additional ounce or fraction of an ounce. Let $L(x)$ be the cost of mailing a letter weighing x ounces. Graph $y = L(x)$.

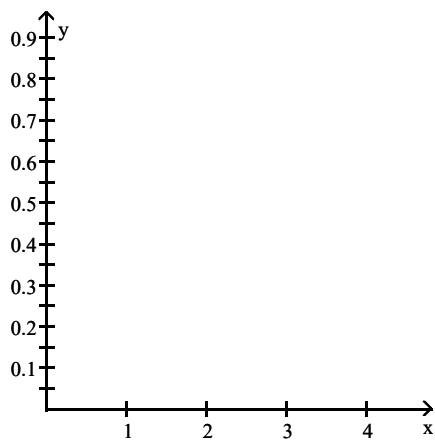

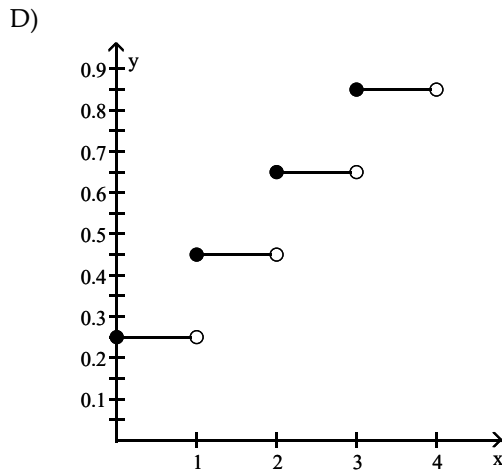
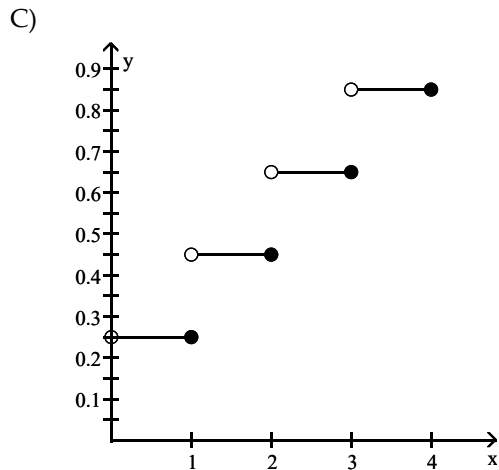
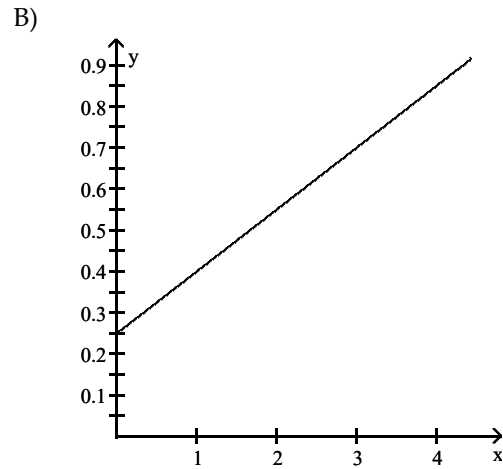
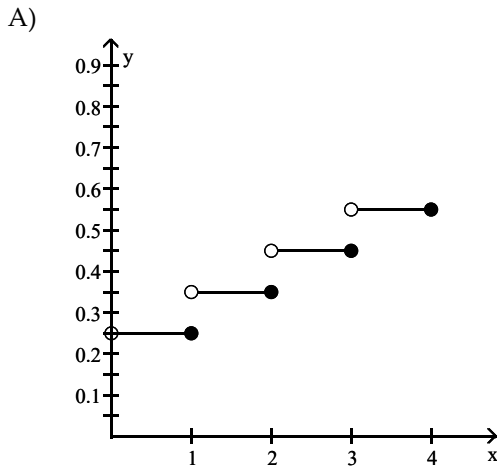

Answer: C

373) A video rental company charges \$5 per day for renting a video tape, and then \$4 per day after the first. Use the greatest integer function and write an expression for renting a video tape for x days.

A) $y + 5 = 4\lceil x \rceil$

B) $y = 4\lceil x - 1 \rceil + 5$

C) $y = \lceil 4x + 5 \rceil$

D) $y = 4x + 5$

Answer: B

374) Suppose a car rental company charges \$138 for the first day and \$88 for each additional or partial day. Let $S(x)$ represent the cost of renting a car for x days. Find the value of $S(3.5)$.

A) \$308

B) \$446

C) \$402

D) \$358

Answer: C

375) Suppose a life insurance policy costs \$28 for the first unit of coverage and then \$7 for each additional unit of coverage. Let $C(x)$ be the cost for insurance of x units of coverage. What will 10 units of coverage cost?

A) \$42

B) \$98

C) \$91

D) \$70

Answer: C

376) The charges for renting a moving van are \$50 for the first 50 miles and \$5 for each additional mile. Assume that a fraction of a mile is rounded up. (i) Determine the cost of driving the van 96 miles. (ii) Find a symbolic representation for a function f that computes the cost of driving the van x miles, where $0 < x \leq 100$. (Hint: express f as a piecewise-constant function.)

A) \$780; $f(x) = \begin{cases} 50 & \text{if } 0 < x \leq 50 \\ 50 + 5(x + 50) & \text{if } 50 < x \leq 100 \end{cases}$

B) \$280; $f(x) = \begin{cases} 50 & \text{if } 0 < x \leq 50 \\ 50 + 5(x - 50) & \text{if } 50 < x \leq 100 \end{cases}$

C) \$5030; $f(x) = \begin{cases} 50x & \text{if } 0 < x \leq 50 \\ 50 + 5(x - 50) & \text{if } 50 < x \leq 100 \end{cases}$

D) \$780; $f(x) = \begin{cases} 50 & \text{if } 0 < x \leq 50 \\ 50 + 5(x - 50) & \text{if } 50 < x \leq 100 \end{cases}$

Answer: B

377) Sketch a graph showing the distance (in miles) that a person is from home after x hours if that individual drives at 35 mph to a lake 70 miles away, stays at the lake 1.5 hours, and then returns home at a speed of 70 mph.

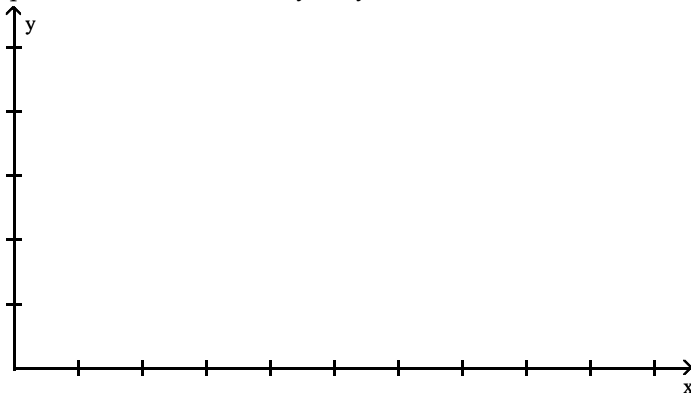

A) none of these

B)

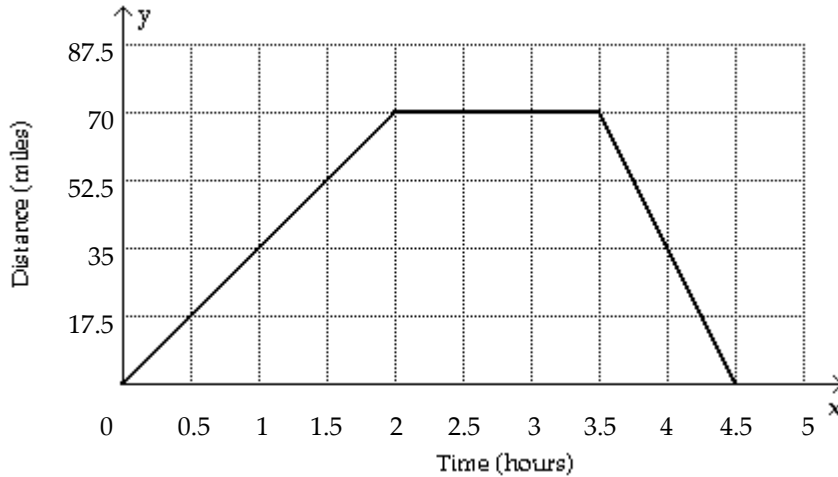

C)

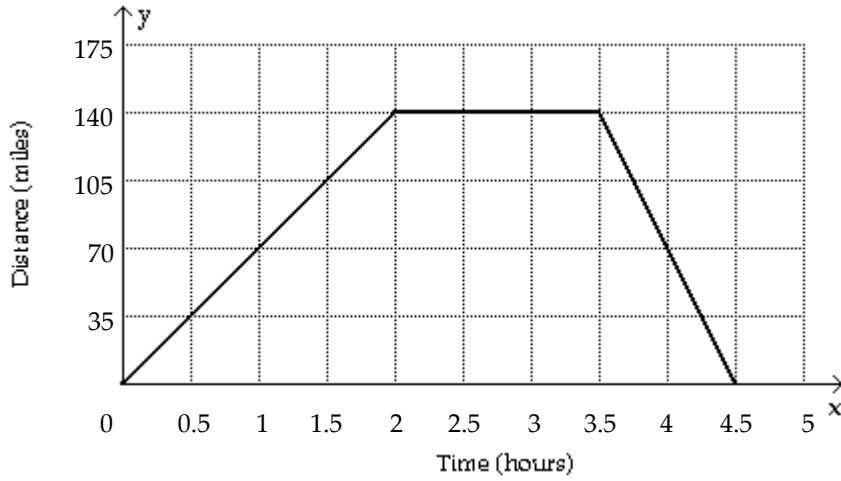

D)

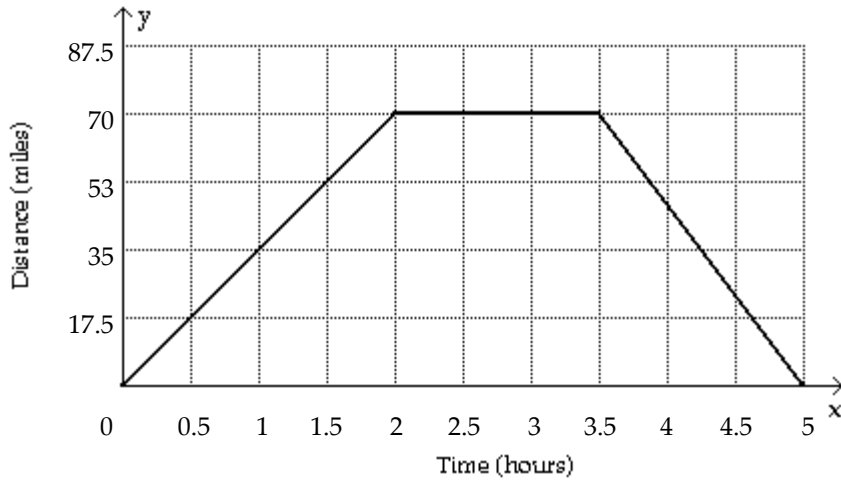

Answer: B

378) The table lists the average composite scores on a national entrance exam for selected years.

Year	2	4	6	8	10	12	14
Score	122.7	131.5	131.5	129.5	133.9	132.0	130.0

(i) Make a line graph of the data.

(ii) If the graph represents a piecewise-linear function f , find a symbolic representation for the piece of f located on the interval $[4, 6]$.

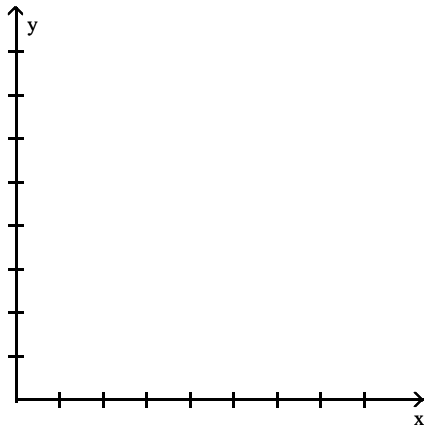

A) none of these

B) $f(x) = 0.75x - 1355$ if $4 \leq x \leq 8$

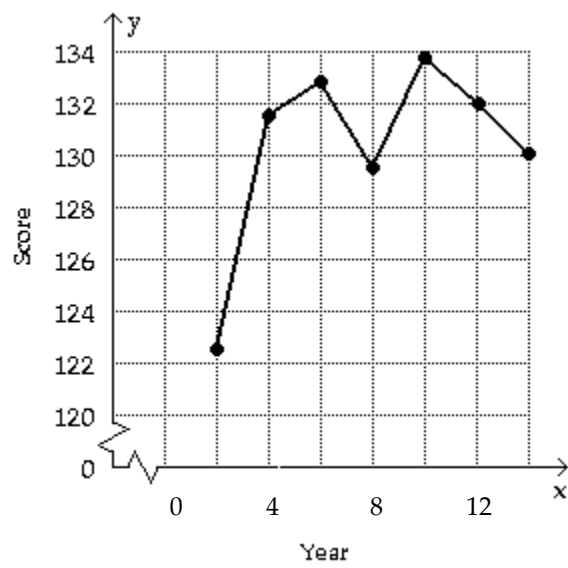

C) $f(x) = 131.5$ if $4 \leq x \leq 6$

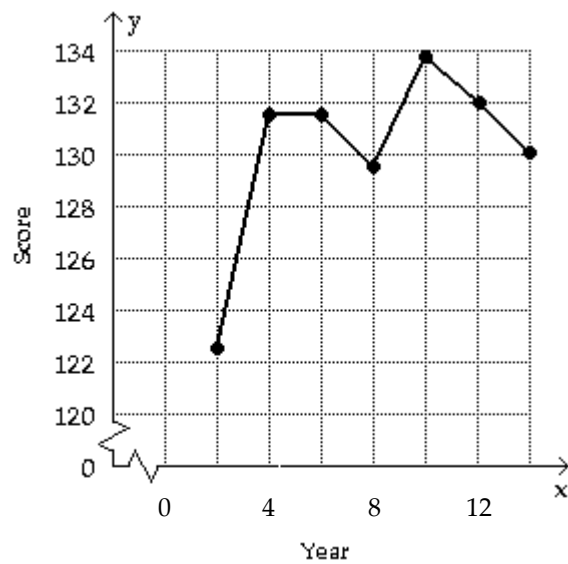

D) $f(x) = 4.4x - 8589.3$ if $8 \leq x \leq 10$

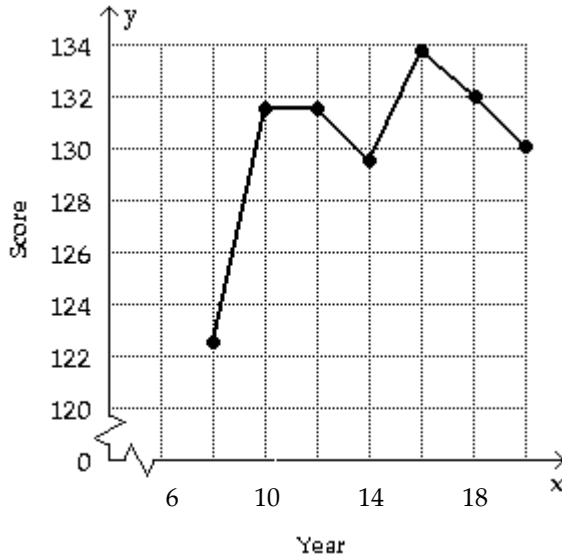

Answer: C

379) In Country X, the average hourly wage in dollars from 1960 to 2010 can be modeled by

$$f(x) = \begin{cases} 0.074(x - 1960) + 0.33 & \text{if } 1960 \leq x < 1995 \\ 0.181(x - 1995) + 3.03 & \text{if } 1995 \leq x \leq 2010 \end{cases}$$

Use f to estimate the average hourly wages in 1965, 1985, and 2005.

A) \$3.40, \$0.33, \$6.65

B) \$0.70, \$2.18, \$6.65

C) \$0.70, \$3.03, \$6.65

Answer: C

Describe how the graph of the equation relates to the graph of $y = x^2$.

380) $f(x) = (x - 7)^2$

A) a translation 7 units down

B) a translation 7 units to the left

C) a translation 7 units to the right

D) a translation 7 units up

Answer: C

381) $f(x) = x^2 + 6$

A) a translation 6 units up

B) a translation 6 units to the right

C) a translation 6 units down

D) a translation 6 units to the left

Answer: A

382) $f(x) = 5x^2$

A) a translation 5 units to the right

B) a horizontal stretch by a factor of 5

C) a translation 5 units up

D) a vertical stretch by a factor of 5

Answer: D

383) $f(x) = -(x + 7)^2$

- A) a translation 7 units to the right and a reflection across the y-axis
- B) a translation 7 units up and a reflection across the x-axis
- C) a translation 7 units to the right and a reflection across the x-axis
- D) a translation 7 units to the left and a reflection across the x-axis

Answer: D

384) $f(x) = (x - 5)^2 + 9$

- A) a translation 5 units to the right and 9 units up
- B) a translation 5 units to the left and 9 units down
- C) a translation 5 units to the left and 9 units up
- D) a translation 9 units to the right and 5 units up

Answer: A

385) $f(x) = \frac{1}{5}x^2 - 3$

- A) vertical stretching by a factor of 5 and a translation 3 units down
- B) vertical shrinking by a factor of $\frac{1}{5}$ and a translation 3 units to the left
- C) vertical stretching by a factor of 5 and a translation 3 units to the right
- D) vertical shrinking by a factor of $\frac{1}{5}$ and a translation 3 units down

Answer: D

Describe how the graph of the equation relates to the graph of $y = \sqrt[3]{x}$.

386) $f(x) = 3\sqrt[3]{x}$

- A) a reflection across the x-axis
- B) a vertical stretching by a factor of 3
- C) a translation 3 units up
- D) a reflection across the y-axis

Answer: B

387) $f(x) = \sqrt[3]{x} + 5$

- A) a vertical stretching by a factor of 5
- B) a reflection across the x-axis
- C) a translation 5 units up
- D) a translation 5 units to the right

Answer: C

Solve the problem.

388) Select the equation that describes the graph shown.

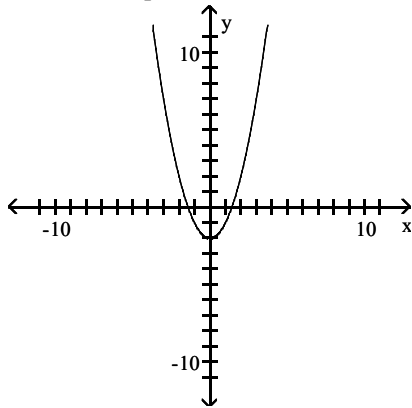

A) $y = (x - 2)^2 + 2$

B) $y = (x + 2)^2$

C) $y = (x - 2)^2$

D) $y = x^2 - 2$

Answer: D

389) Select the equation that describes the graph shown.

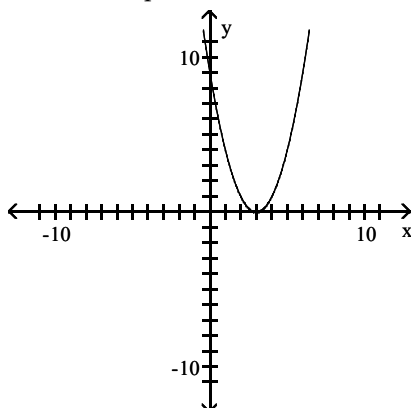

A) $y = (x + 3)^2$

B) $y = x^2 + 3$

C) $y = (x - 3)^2$

D) $y = x^2 - 3$

Answer: C

390) Select the equation that describes the graph shown.

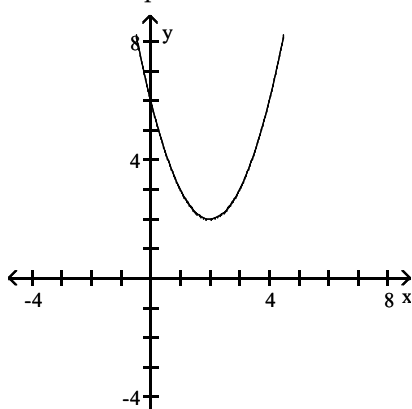

A) $y = (x + 2)^2 + 2$

B) $y = (x - 2)^2 + 2$

C) $y = (x + 2)^2 - 2$

D) $y = x^2 - 2$

Answer: B

391) Select the equation that describes the graph shown.

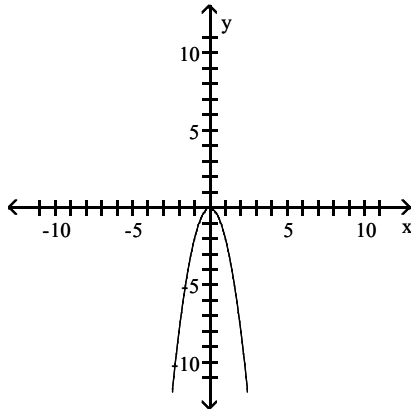

A) $y = -\frac{1}{2}x^2$

B) $y = -2x^2$

C) $y = 2x^2$

D) $y = -x^2$

Answer: B

392) Select the equation that describes the graph shown.

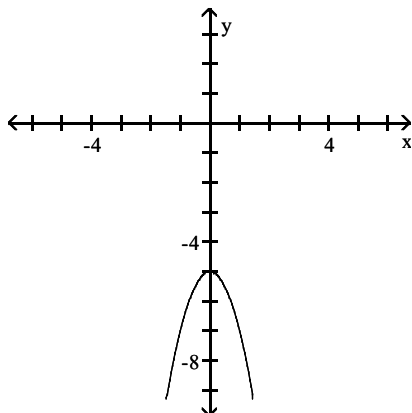

A) $y = -2(x + 5)^2$

B) $y = -2(x - 5)^2 + 2$

C) $y = -2x^2 - 5$

D) $y = -2(x - 5)^2$

Answer: C

393) Select the equation that describes the graph shown.

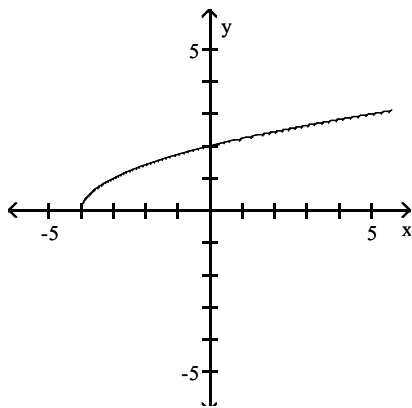

A) $y = \sqrt{x} + 4$

B) $y = \sqrt{x + 4} + 3$

C) $y = \sqrt{x - 4}$

D) $y = \sqrt{x + 4}$

Answer: D

394) Select the equation that describes the graph shown.

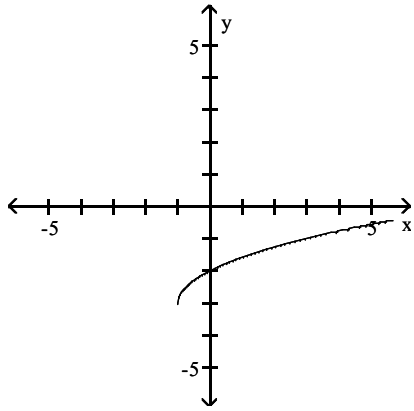

A) $y = \sqrt{x+1} + 3$

B) $y = \sqrt{x} - 3$

C) $y = \sqrt{x-1} - 3$

D) $y = \sqrt{x+1} - 3$

Answer: D

Graph the function.

395) $f(x) = 7x^2$

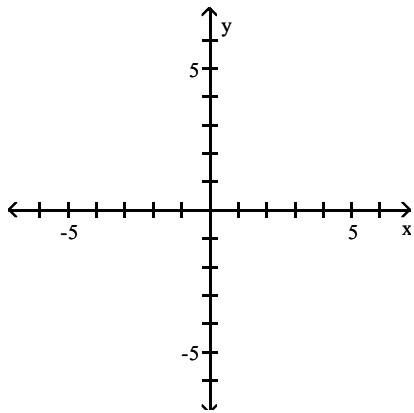

A)

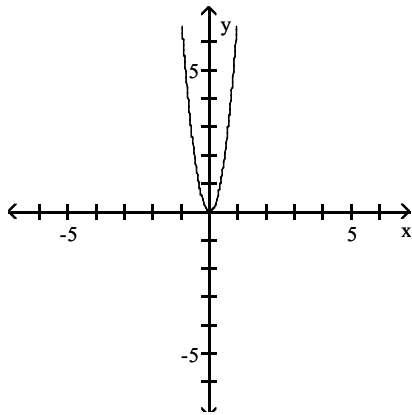

B)

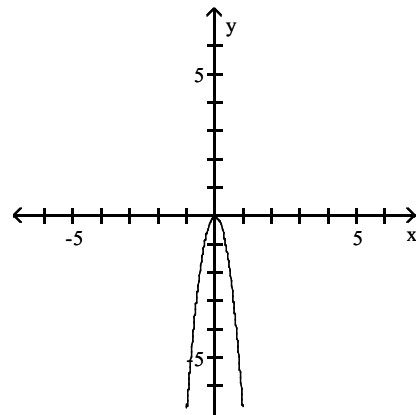

C)

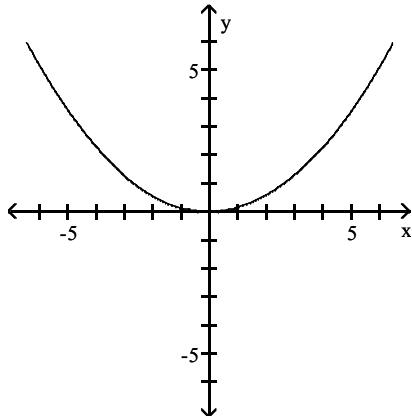

D)

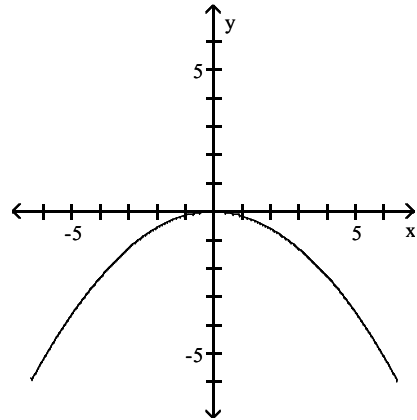

Answer: A

396) $f(x) = \frac{1}{2}x^3$

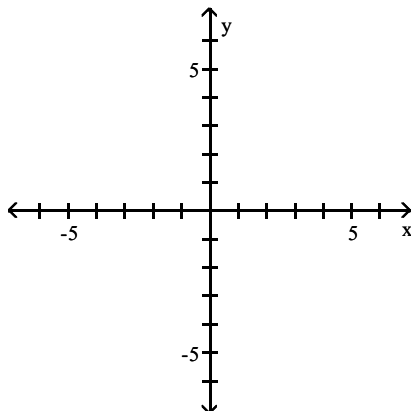

A)

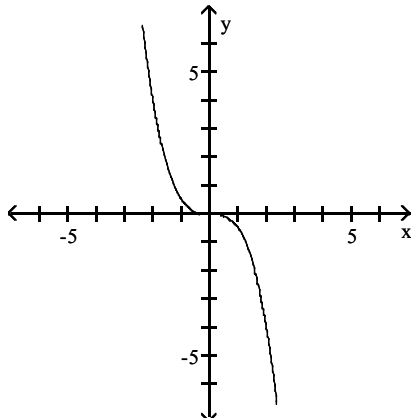

B)

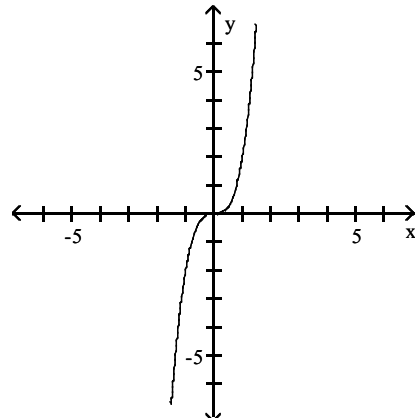

C)

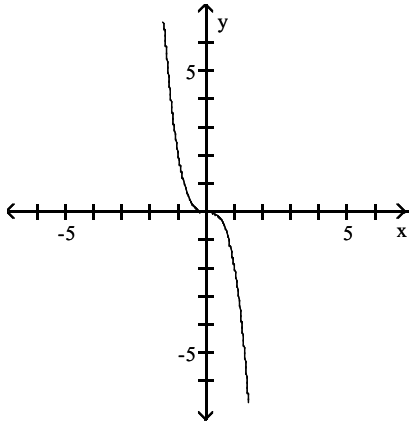

D)

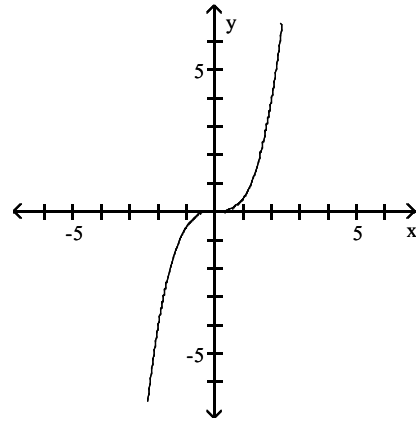

Answer: D

397) $f(x) = 4\sqrt{x}$

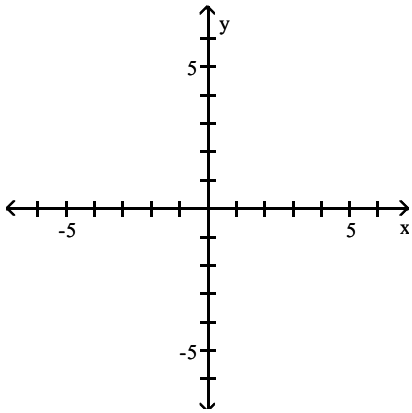

A)

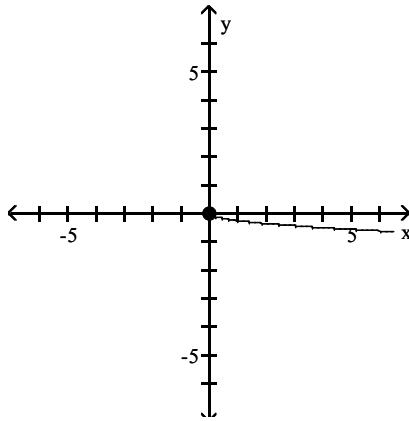

B)

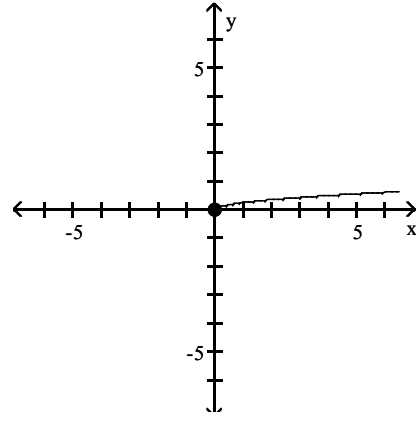

C)

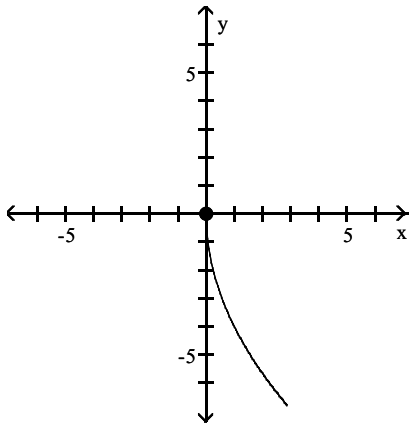

D)

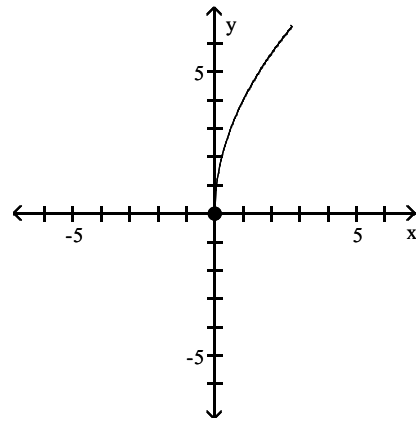

Answer: D

398) $f(x) = (3x)^2$

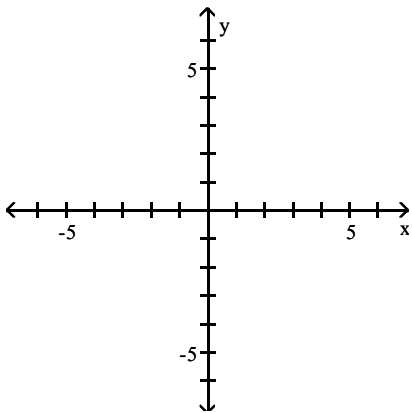

A)

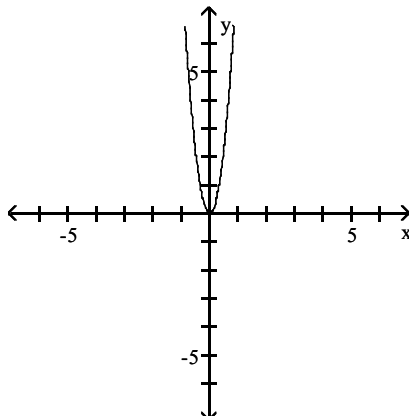

B)

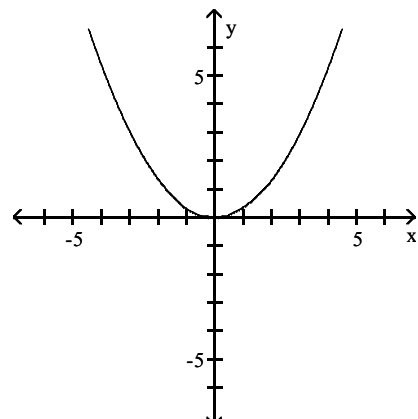

C)

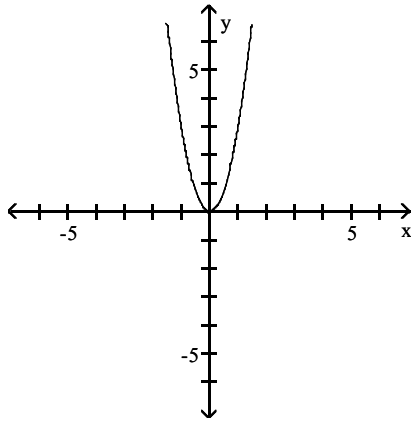

D)

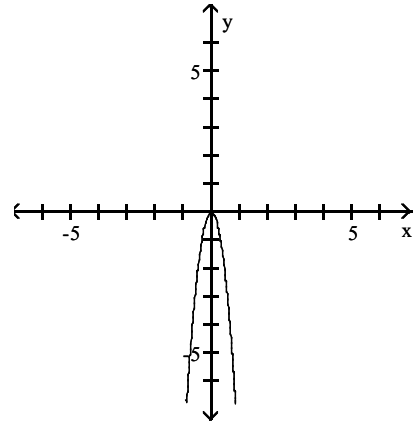

Answer: A

399) $f(x) = |4x|$

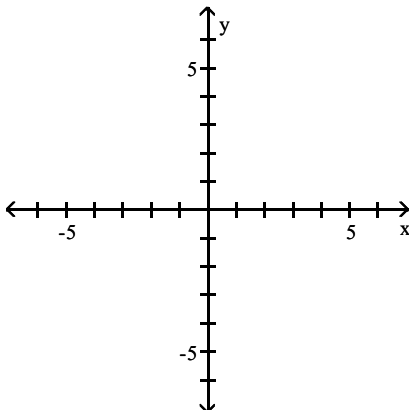

A)

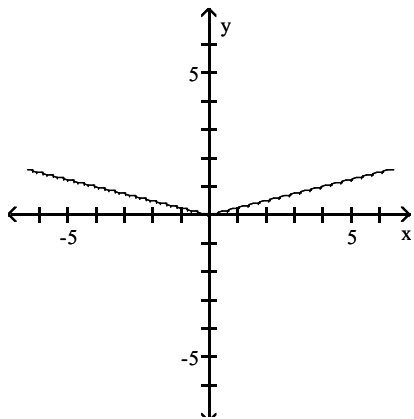

B)

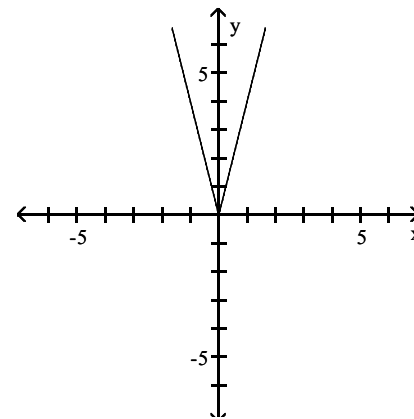

C)

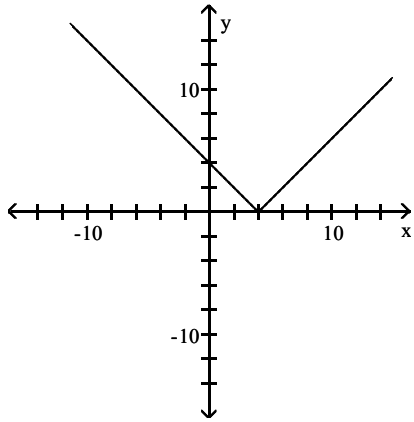

D)

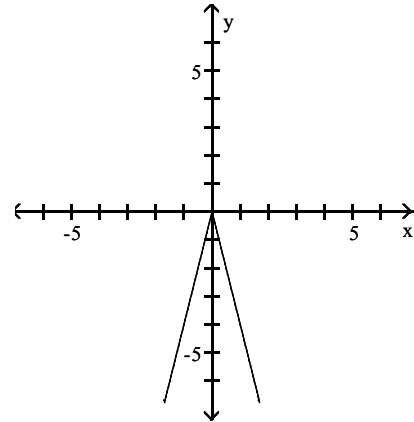

Answer: B

400) $f(x) = -2|x|$

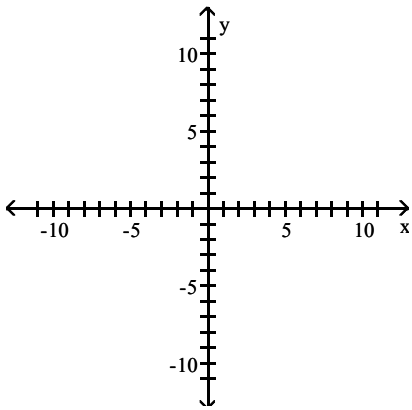

A)

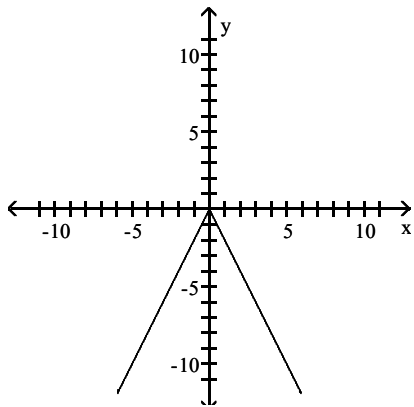

B)

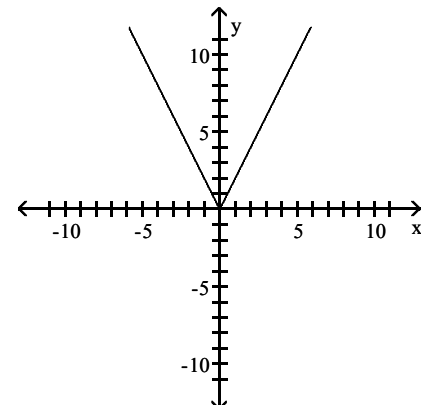

C)

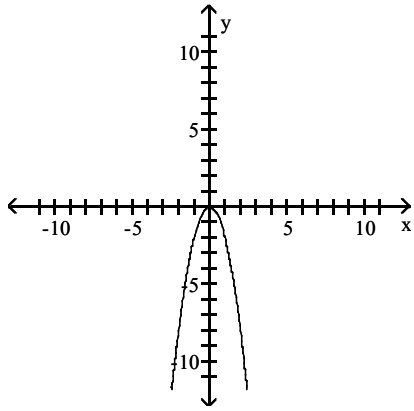

D)

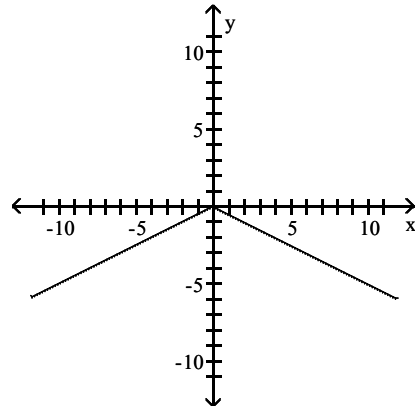

Answer: A

401) $f(x) = -\frac{1}{6}x^2$

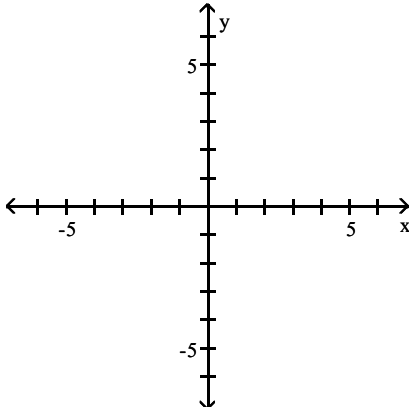

A)

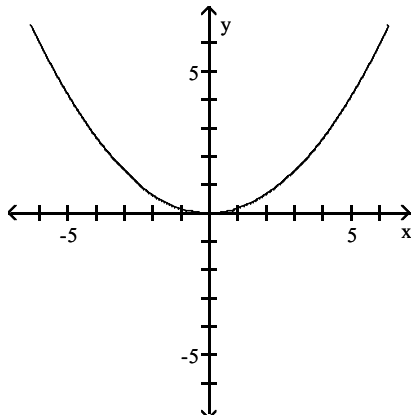

B)

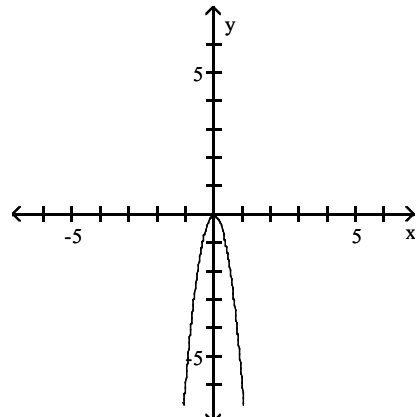

C)

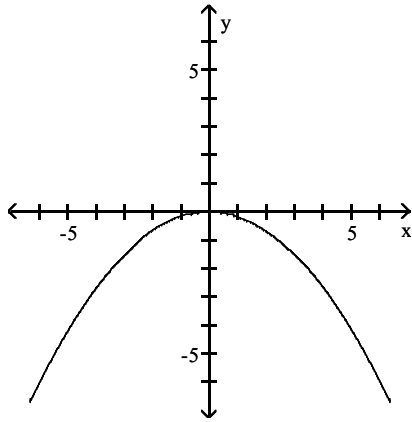

Answer: C

402) $f(x) = 7(-x)^3$

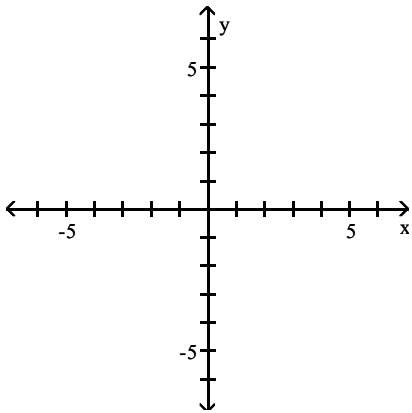

A)

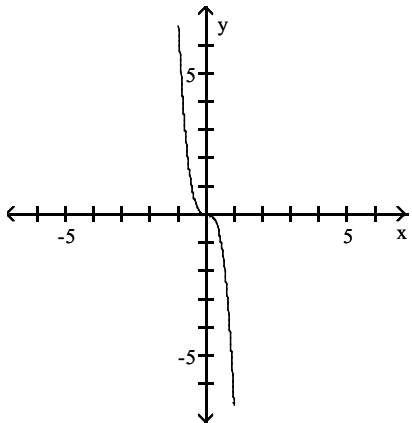

D)

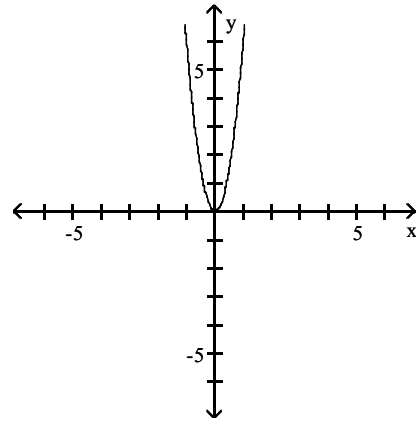

B)

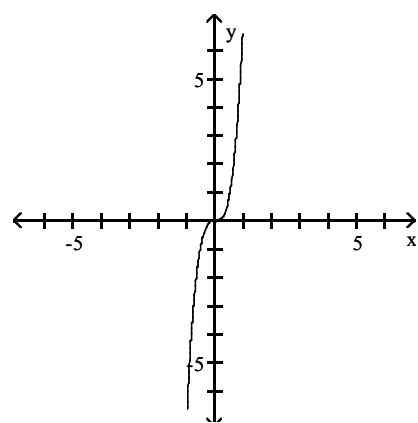

C)

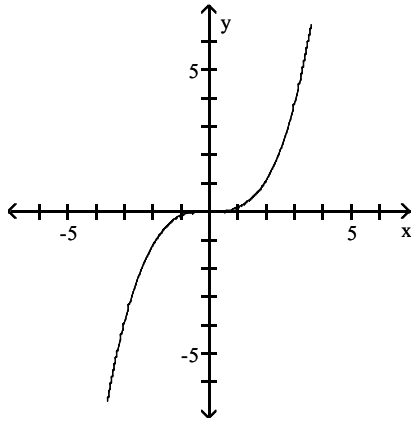

D)

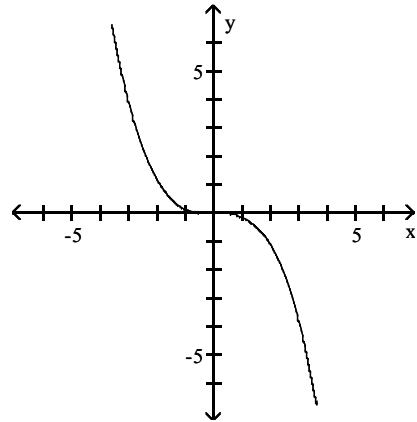

Answer: A

403) $f(x) = \frac{1}{5}\sqrt{-x}$

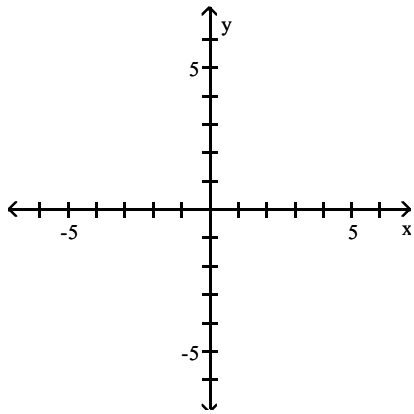

A)

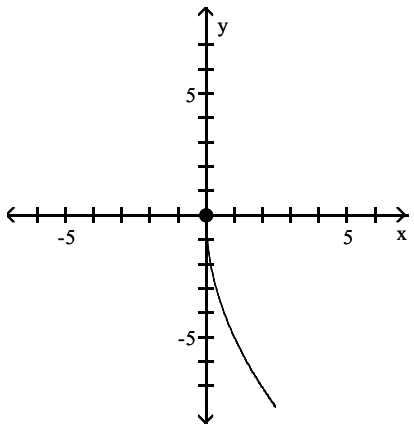

B)

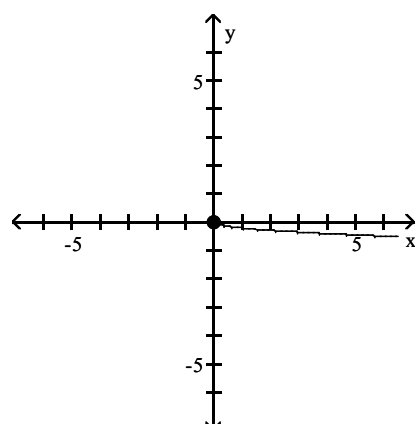

C)

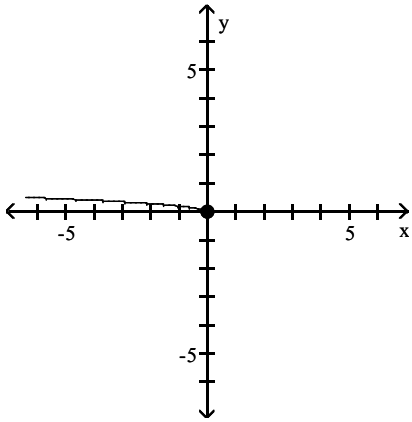

D)

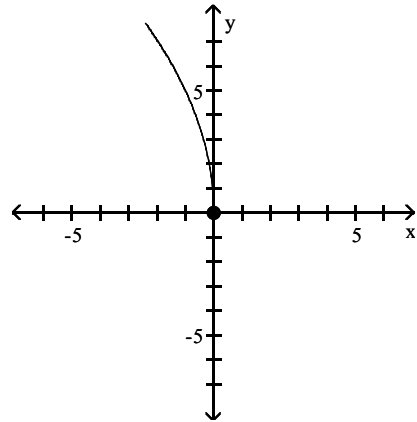

Answer: C

404) $f(x) = \frac{1}{6}|-x|$

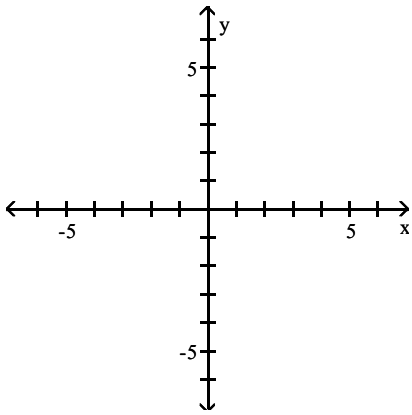

A)

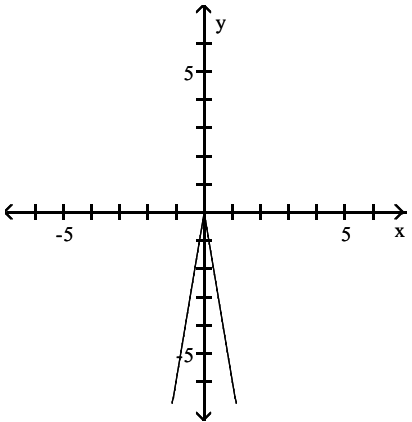

B)

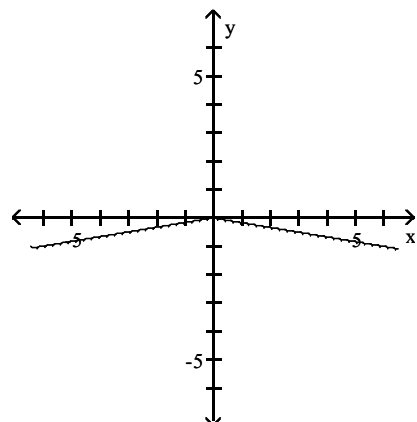

C)

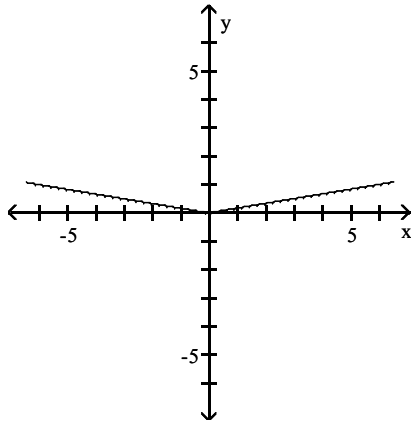

D)

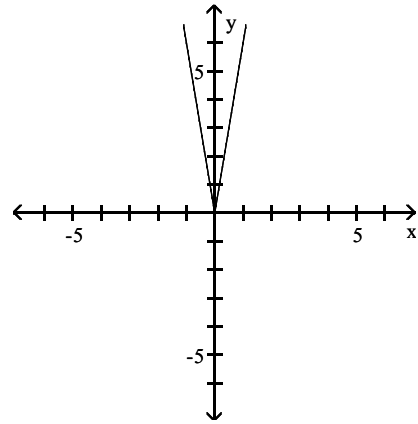

Answer: C

405) $y = x^2 + 1$

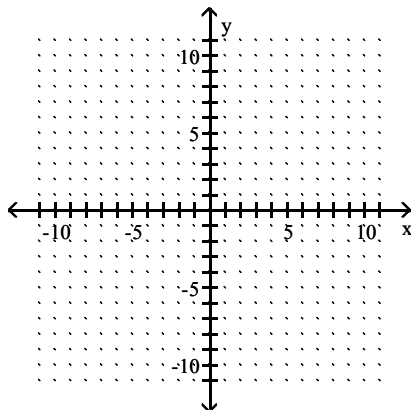

A)

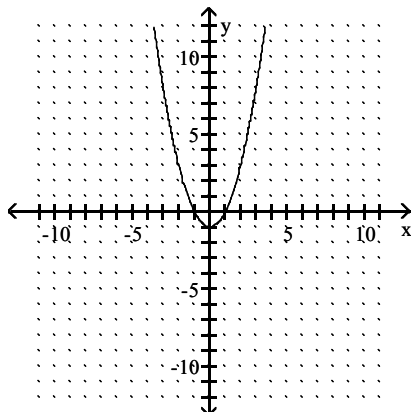

B)

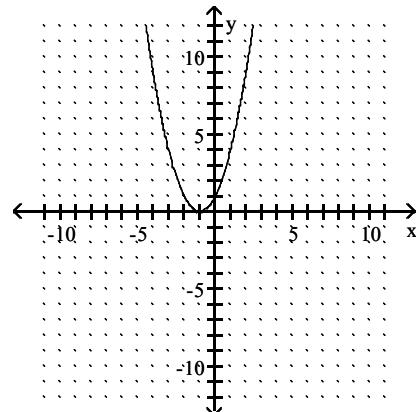

C)

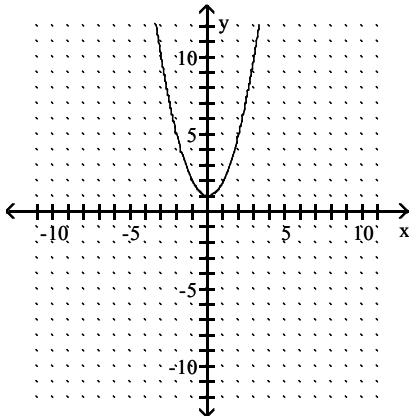

D)

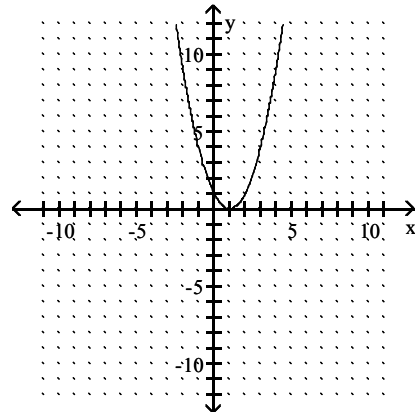

Answer: C

406) $f(x) = (x + 3)^2$

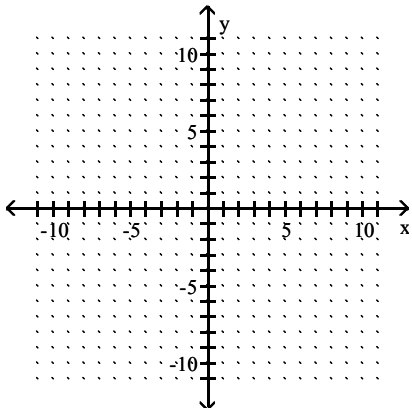

A)

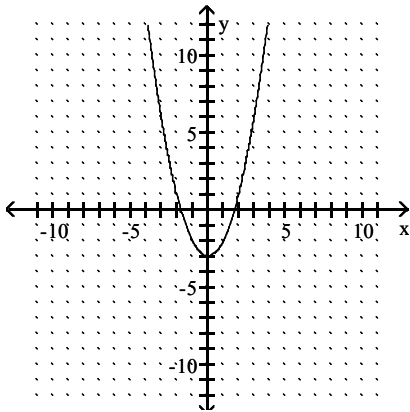

B)

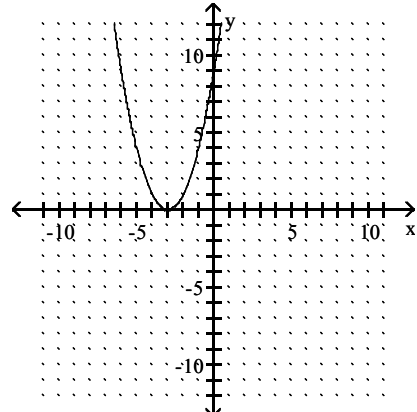

C)

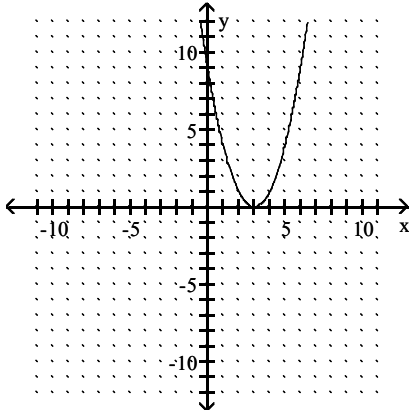

D)

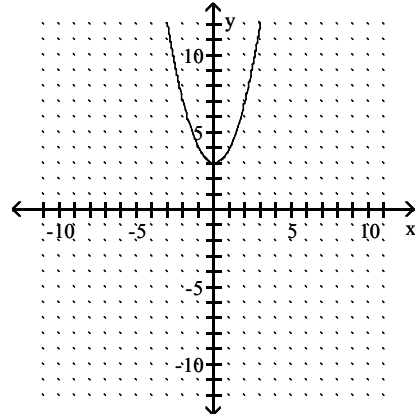

Answer: B

407) $y = (x - 3)^2 - 3$

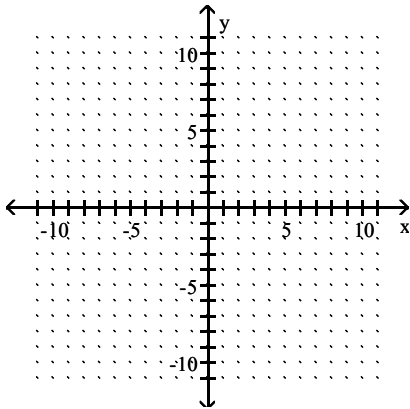

A)

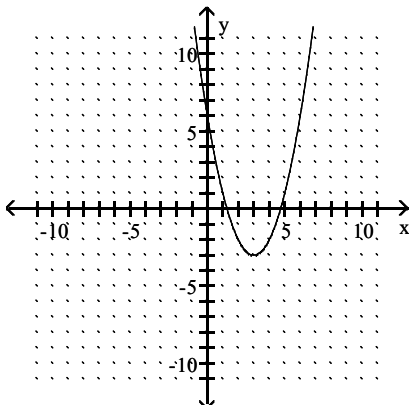

B)

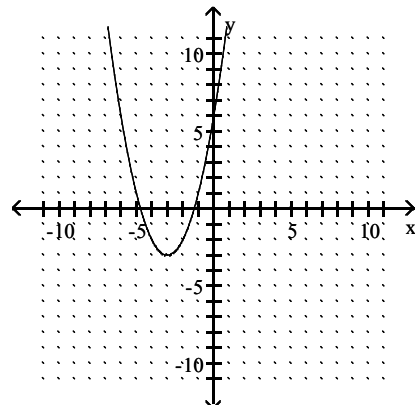

C)

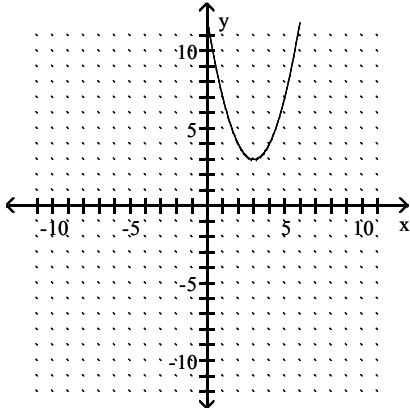

D)

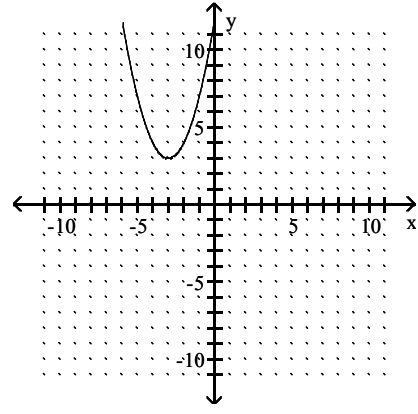

Answer: A

408) $f(x) = x^3 - 1$

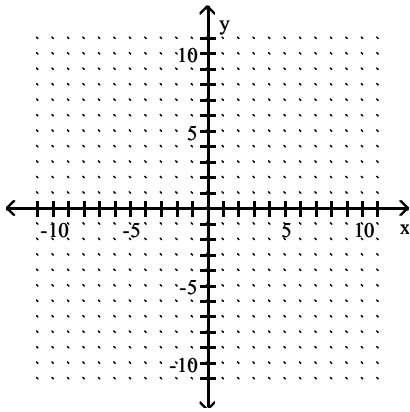

A)

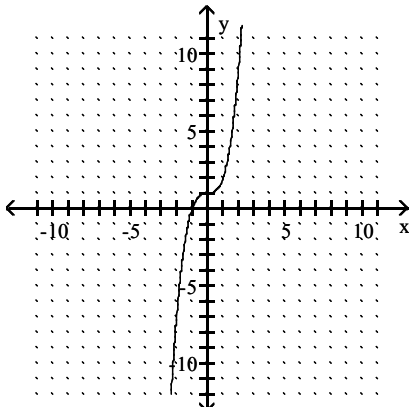

B)

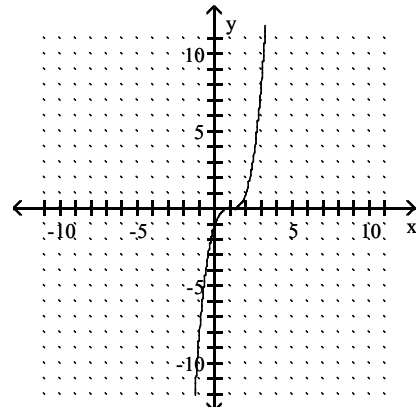

C)

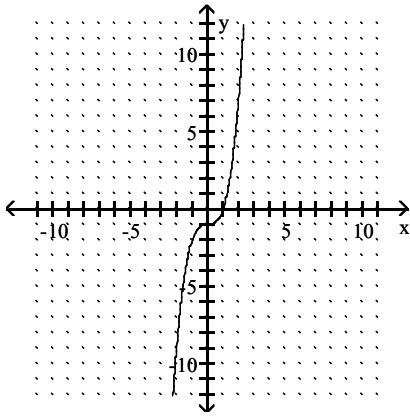

D)

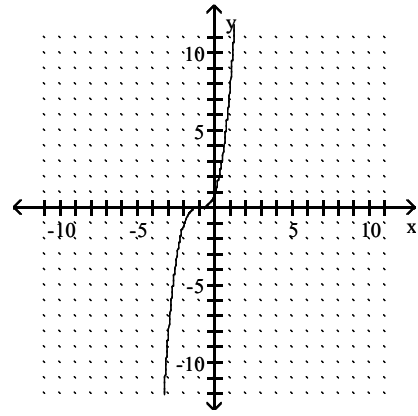

Answer: C

409) $y = (x + 3)^3$

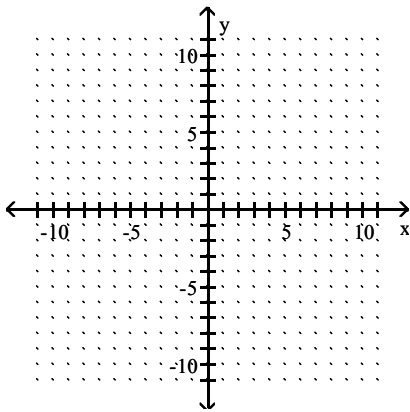

A)

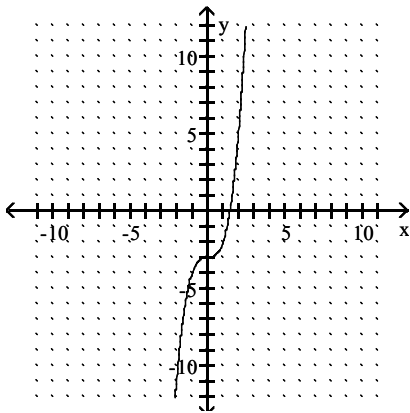

B)

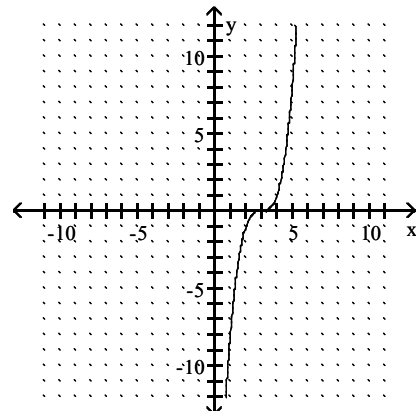

C)

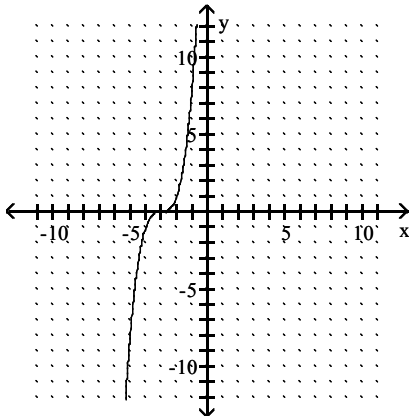

D)

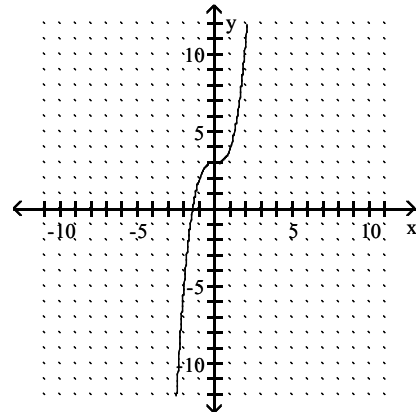

Answer: C

410) $f(x) = (x + 2)^3 - 3$

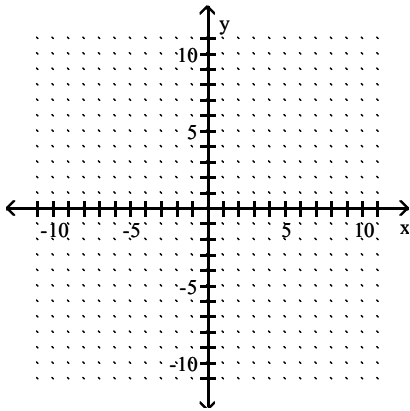

A)

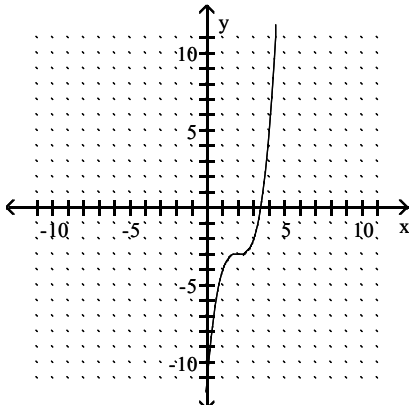

B)

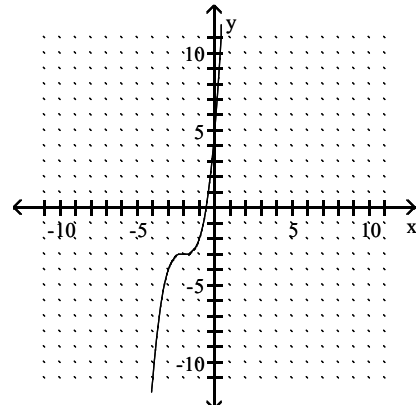

C)

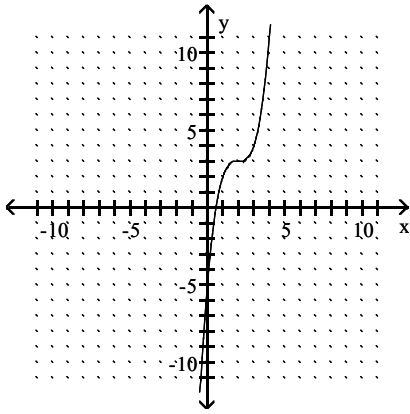

D)

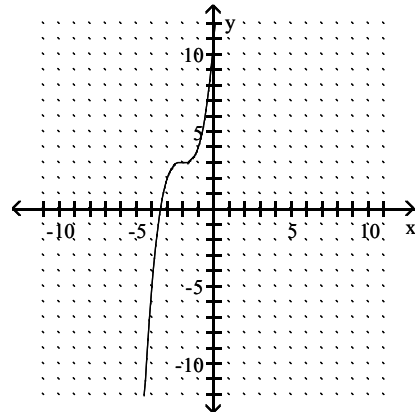

Answer: B

411) $y = \sqrt{x+5}$

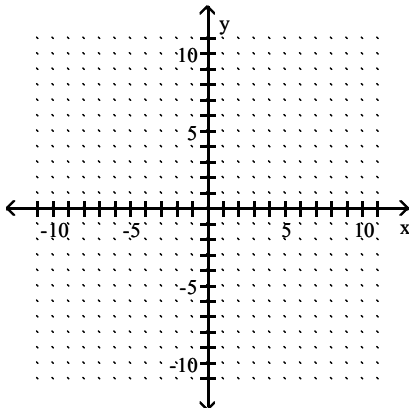

A)

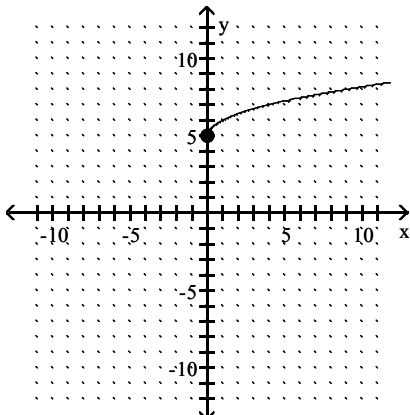

B)

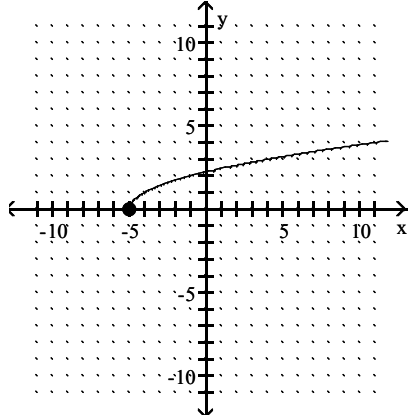

C)

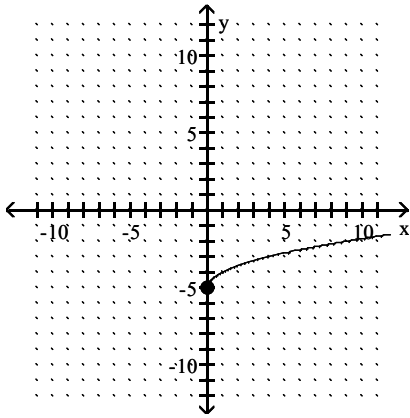

D)

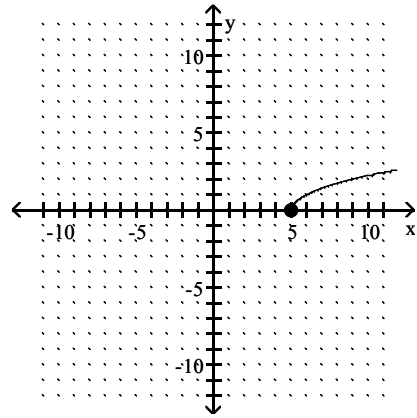

Answer: B

412) $y = \sqrt{x - 6} + 7$

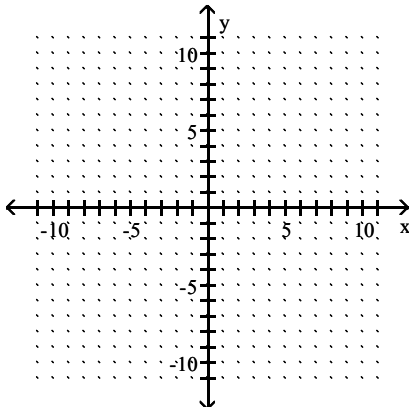

A)

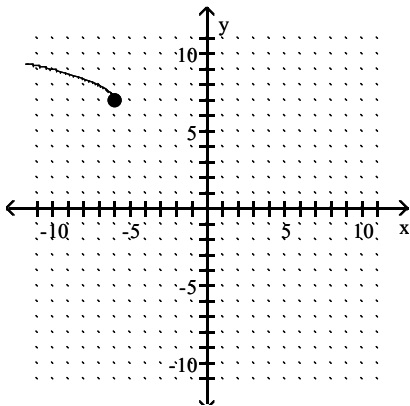

B)

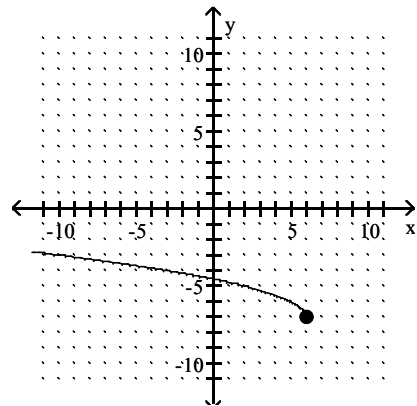

C)

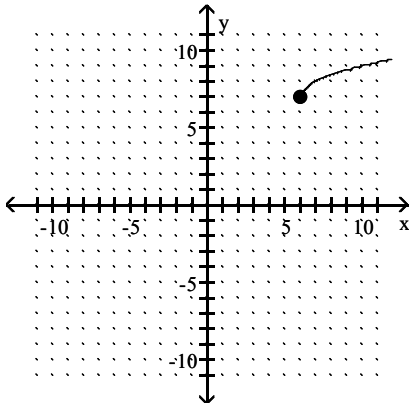

D)

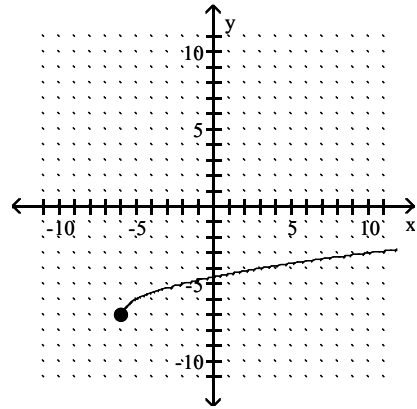

Answer: C

413) $f(x) = |x| - 3$

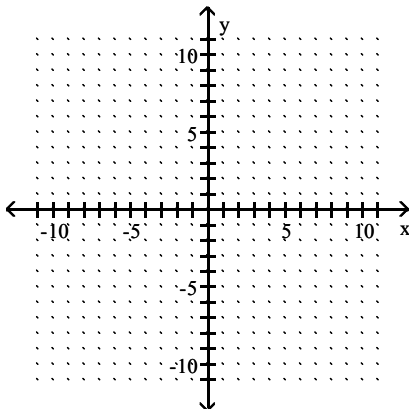

A)

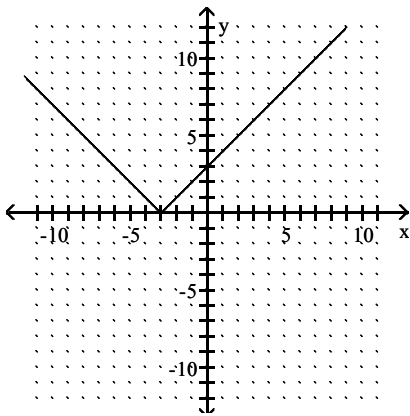

B)

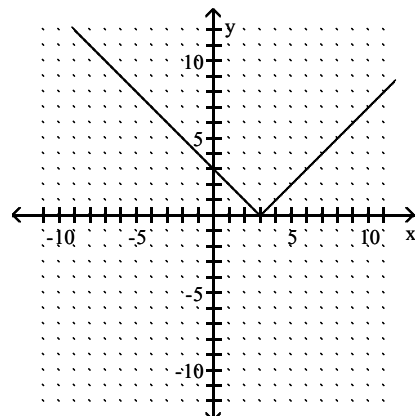

C)

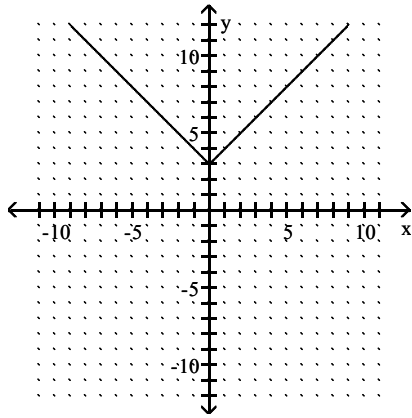

D)

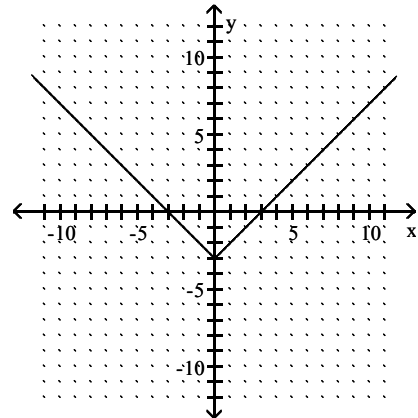

Answer: D

414) $y = |x + 5| + 3$

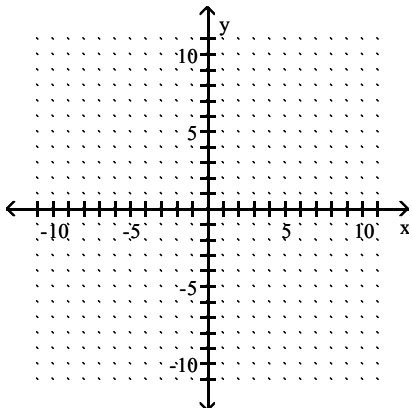

A)

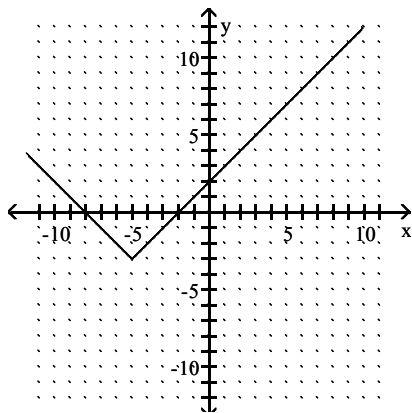

B)

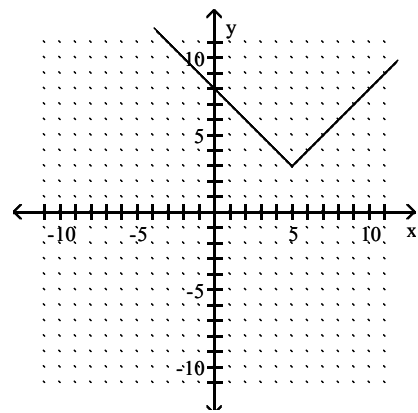

C)

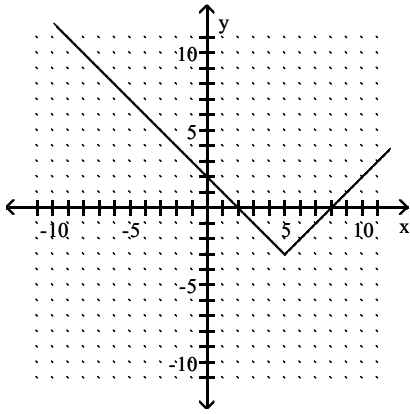

D)

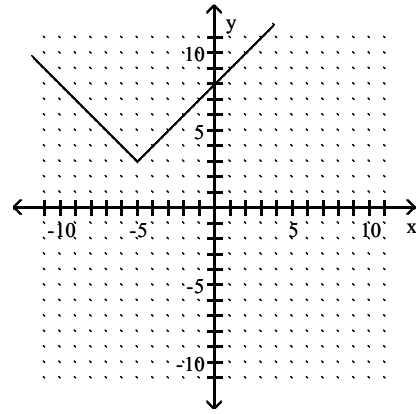

Answer: D

415) $y = -\frac{1}{4}(x + 3)^3$

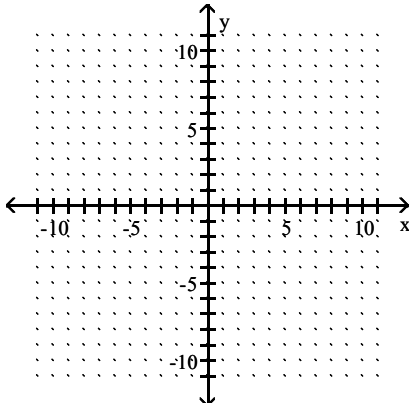

A)

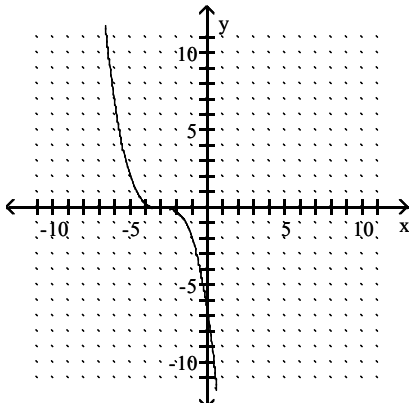

B)

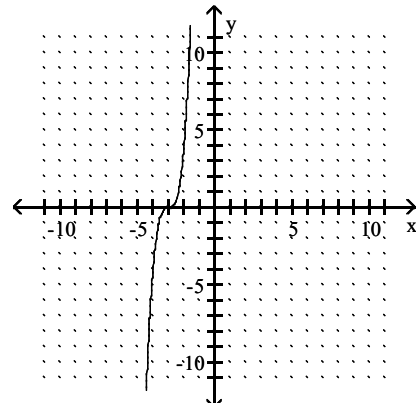

C)

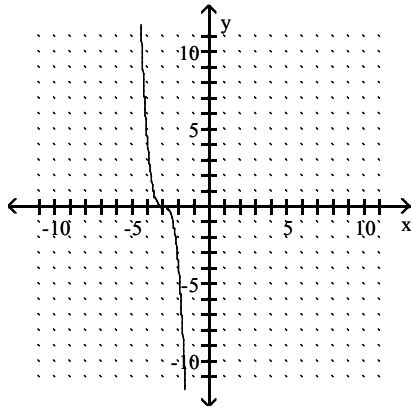

D)

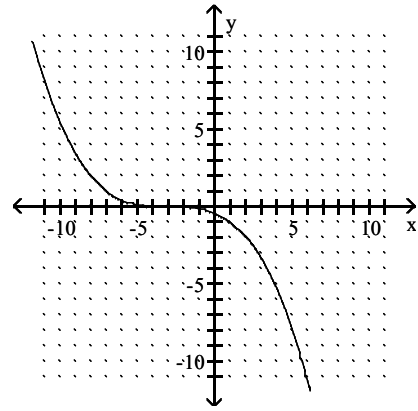

Answer: A

416) $f(x) = 3(x + 1)^2 - 3$

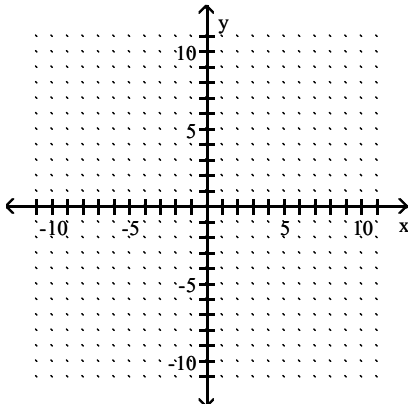

A)

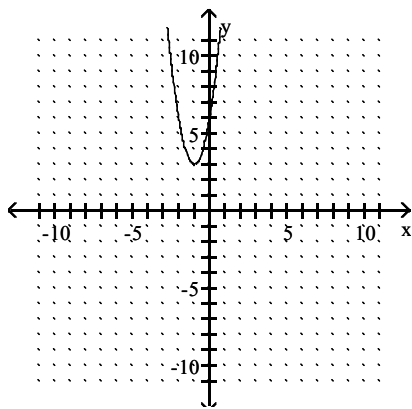

B)

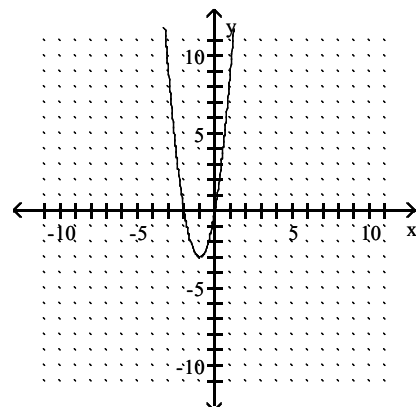

C)

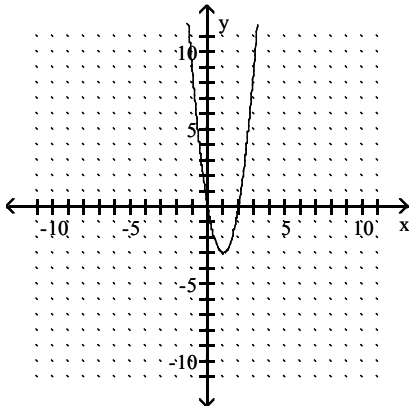

D)

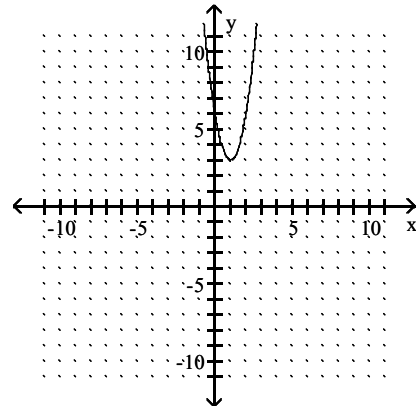

Answer: B

417) $y = -\frac{1}{2}(x + 4)^4 + 2$

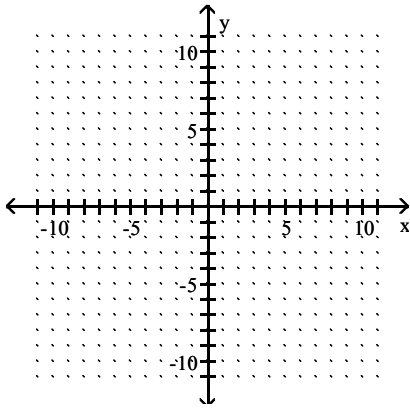

A)

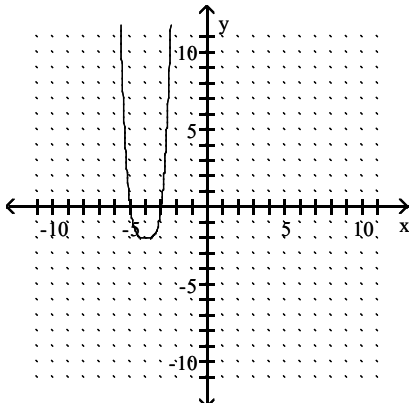

B)

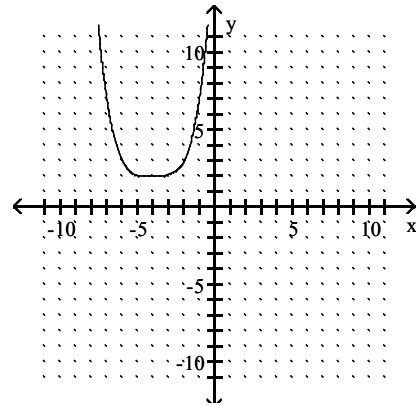

C)

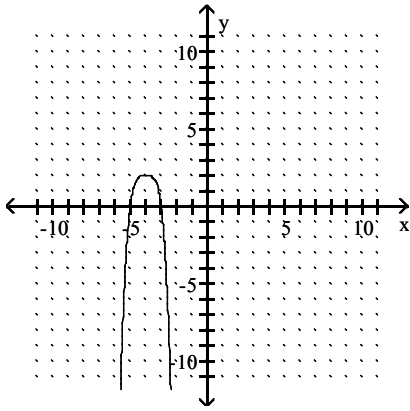

D)

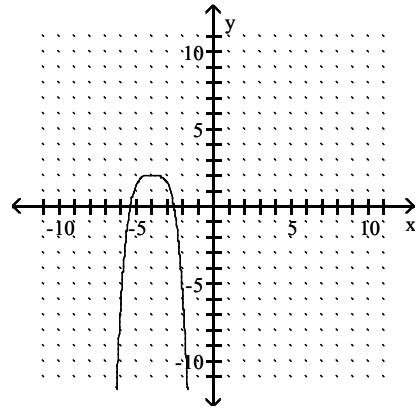

Answer: D

418) $f(x) = -(x - 6)^2 - 2$

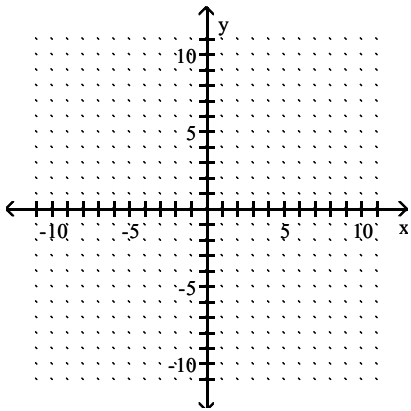

A)

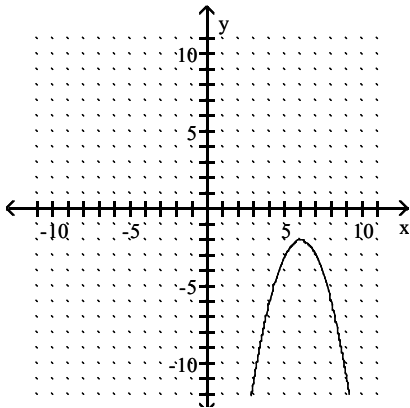

B)

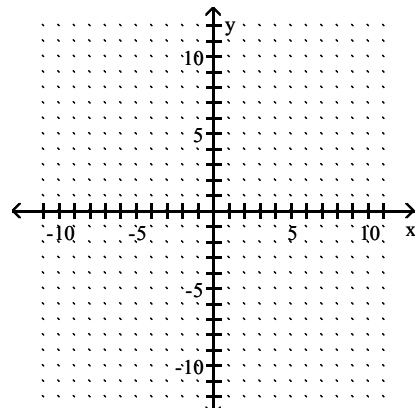

C)

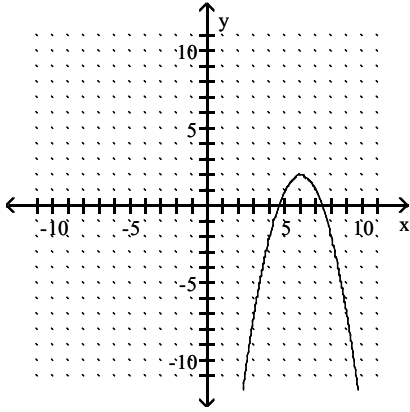

D)

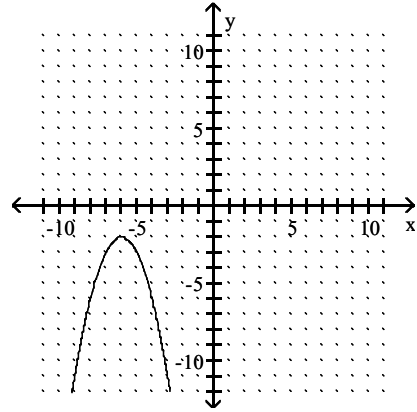

Answer: A

419) $y = 3x^2 - 1$

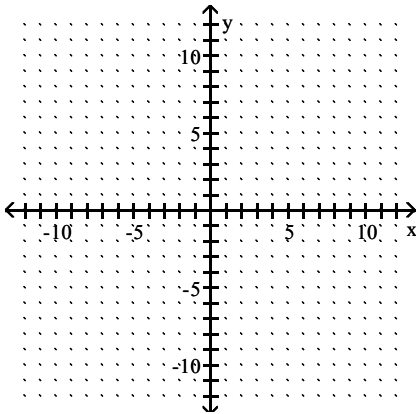

A)

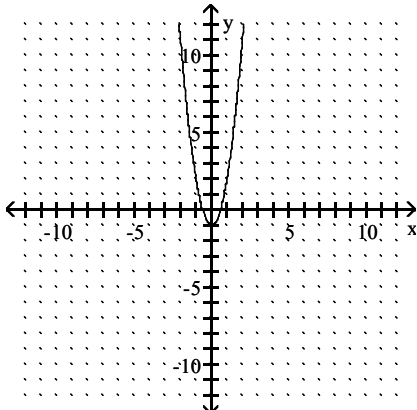

B)

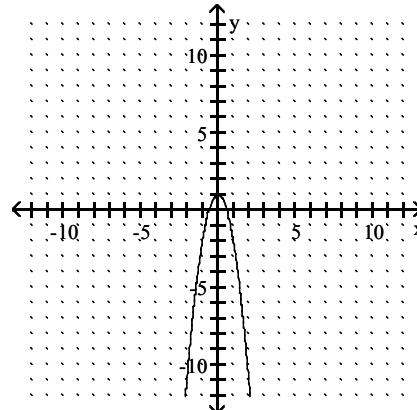

C)

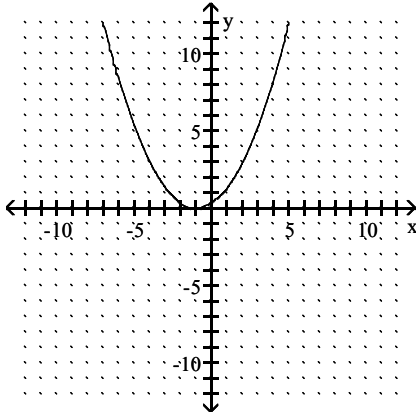

D)

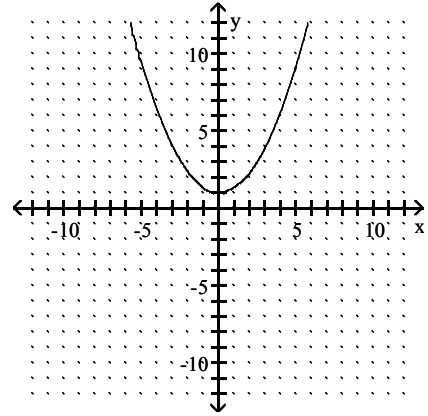

Answer: A

420) $y = 8|x| - 9$

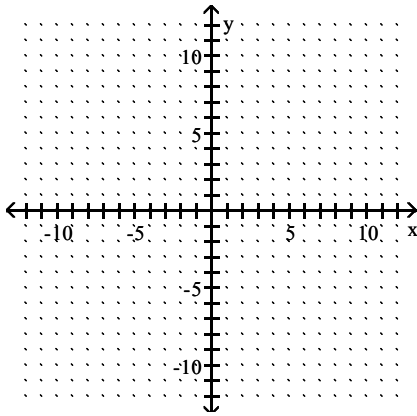

A)

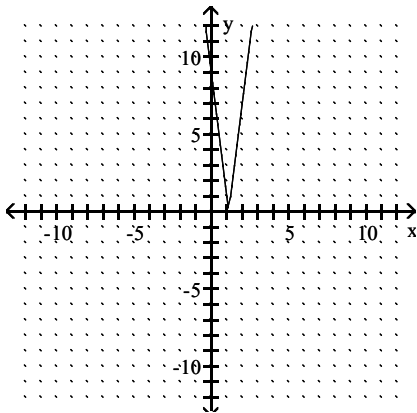

B)

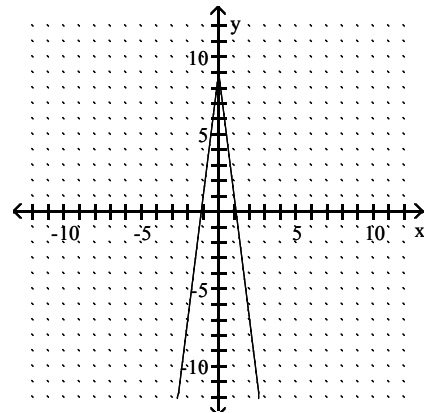

C)

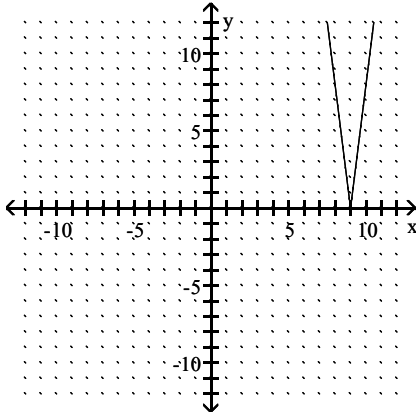

D)

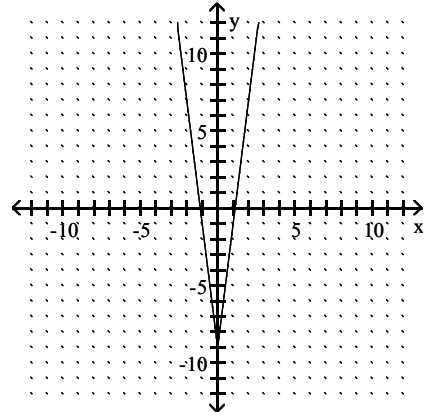

Answer: D

421) $g(x) = -\sqrt{x+2} - 1$

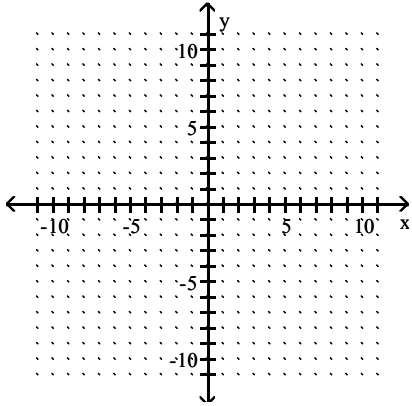

A)

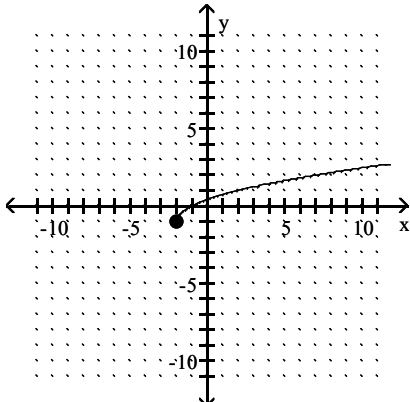

B)

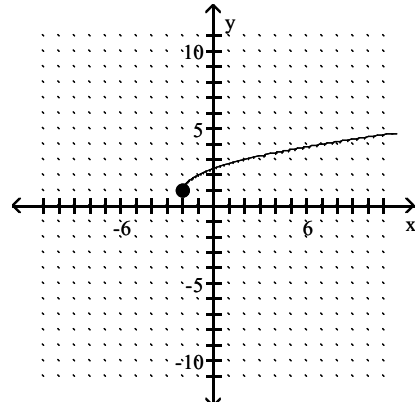

C)

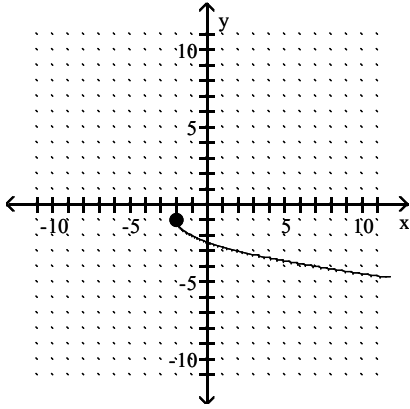

D)

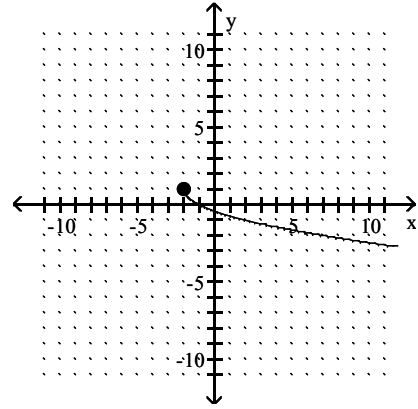

Answer: C

422) $h(x) = \sqrt{-x+1} + 2$

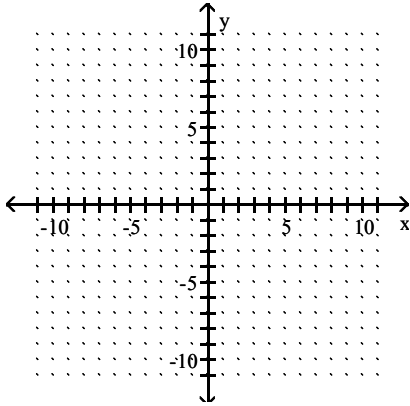

A)

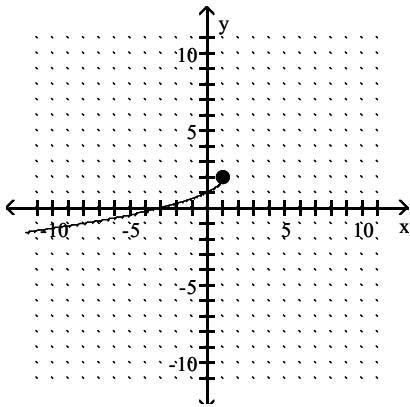

B)

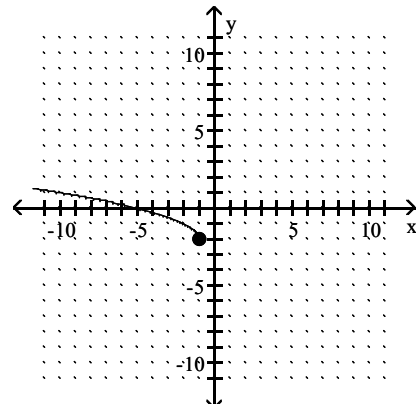

C)

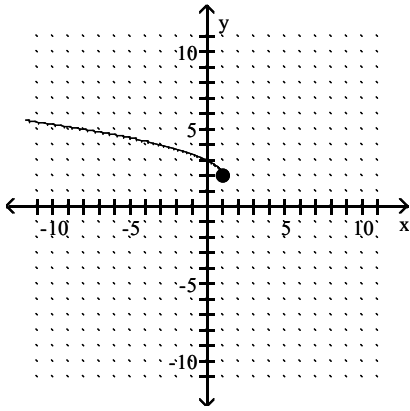

D)

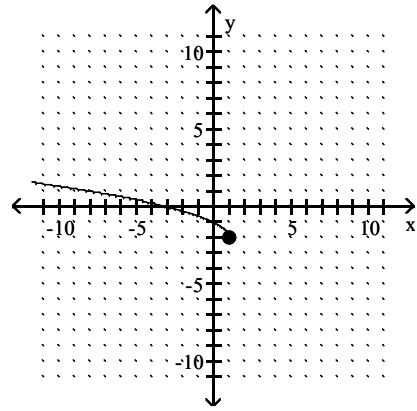

Answer: C

$$423) g(x) = \frac{1}{4}|x - 5| - 6$$

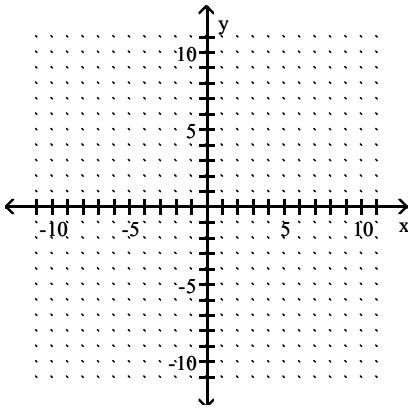

A)

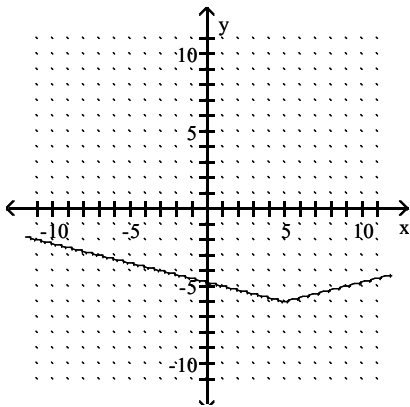

B)

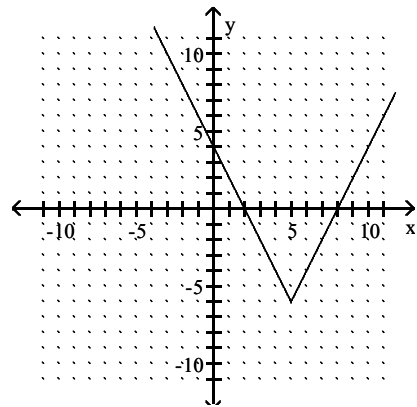

C)

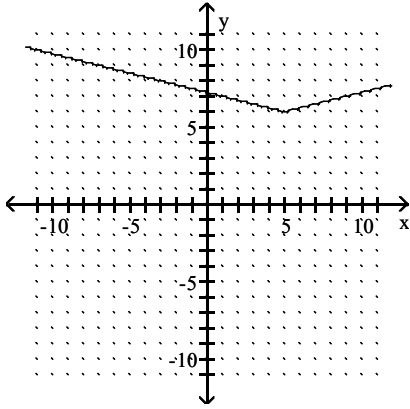

D)

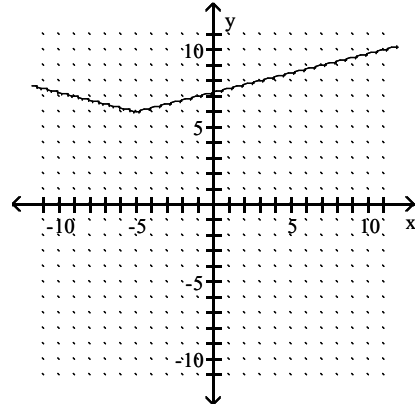

Answer: A

424) $g(x) = -(x + 4)^3 - 2$

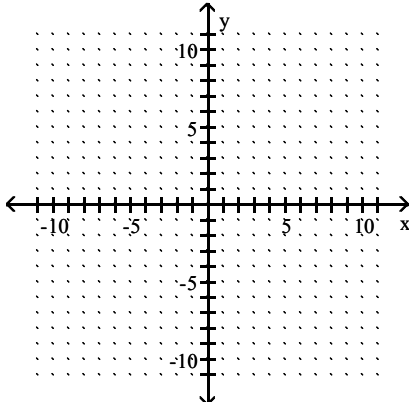

A)

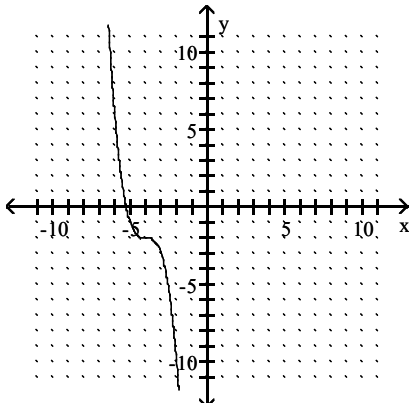

B)

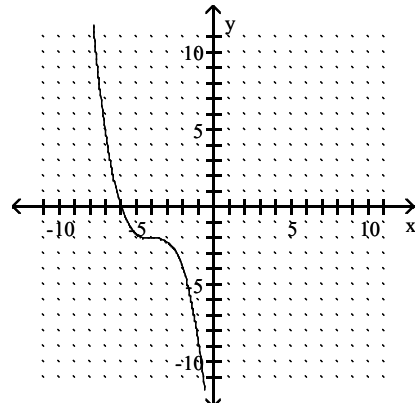

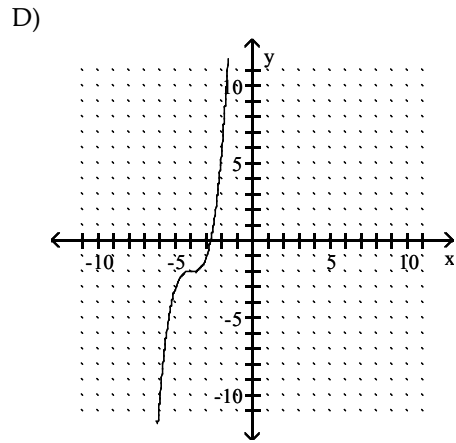
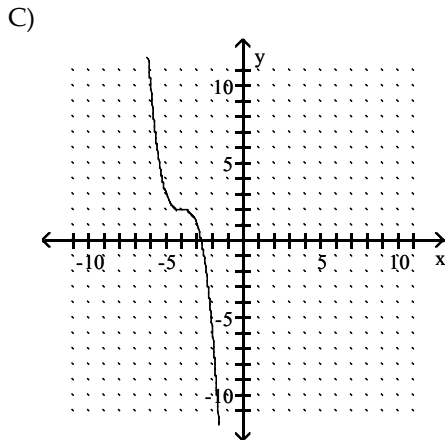

Answer: A

Suppose the point $(2, 4)$ is on the graph of $y = f(x)$. Find a point on the graph of the given function.

425) $y = f(x + 3)$

A) $(-1, 4)$

B) $(5, 4)$

C) $(2, 7)$

D) $(2, 1)$

Answer: A

426) $y = f(x) + 6$

A) $(-4, 4)$

B) $(2, -6)$

C) $(8, 4)$

D) $(2, 10)$

Answer: D

427) $y = 3f(x)$

A) $(2, 6)$

B) $(2, 12)$

C) $(6, 4)$

D) $(5, 2)$

Answer: B

428) The reflection of the graph of $y = f(x)$ across the x -axis

A) $(-2, 4)$

B) $(2, -4)$

C) $(-2, -4)$

D) $(2, 4)$

Answer: B

429) The reflection of the graph of $y = f(x)$ across the y -axis

A) $(2, 4)$

B) $(2, -4)$

C) $(-2, 4)$

D) $(-2, -4)$

Answer: C

The figure below shows the graph of a function $y = f(x)$. Use this graph to solve the problem.

430) Sketch the graph of $y = -f(x)$.

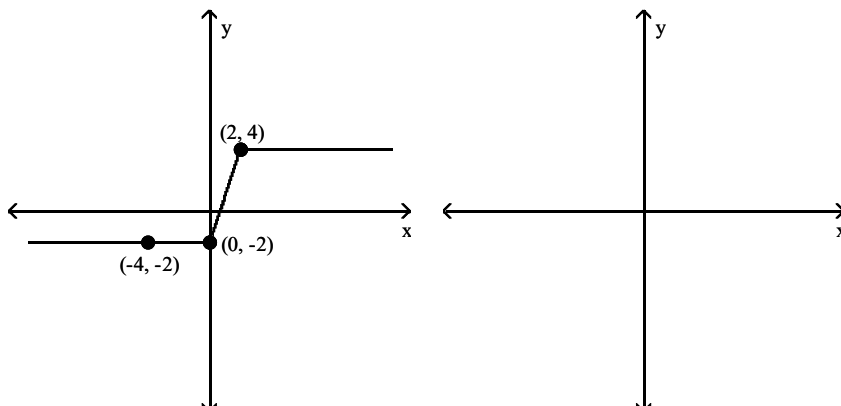

A)

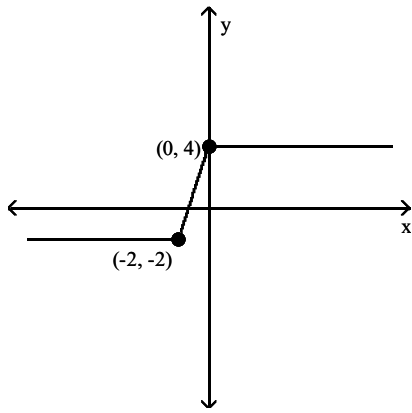

B)

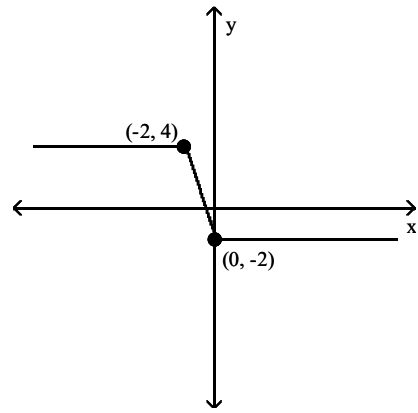

C)

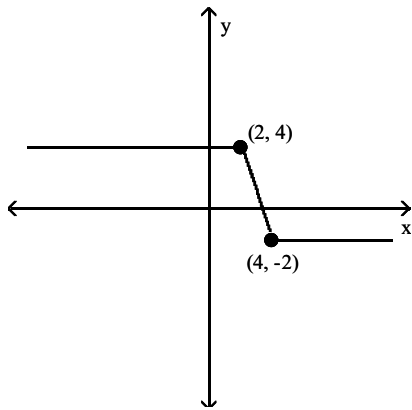

D)

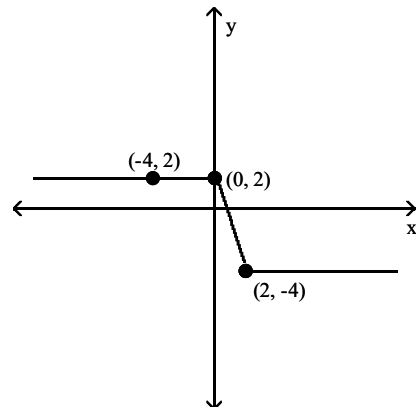

Answer: D

431) Sketch the graph of $y = f(-x)$.

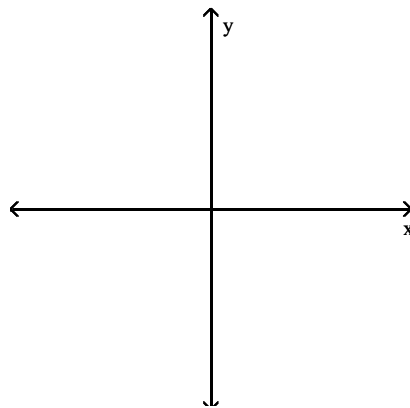
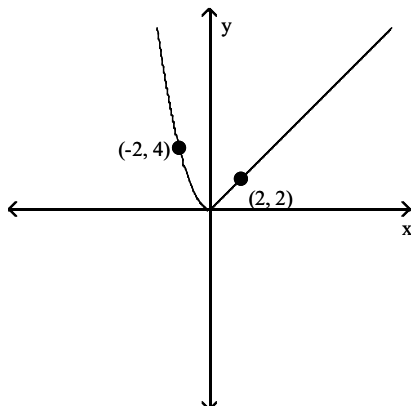

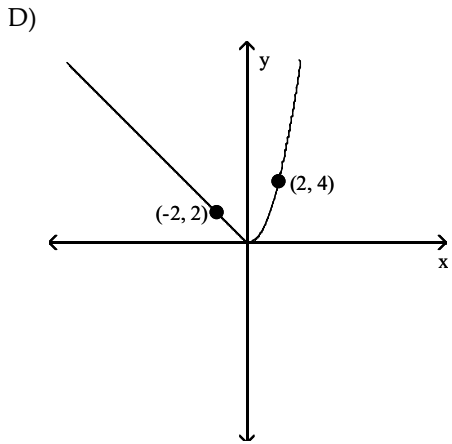
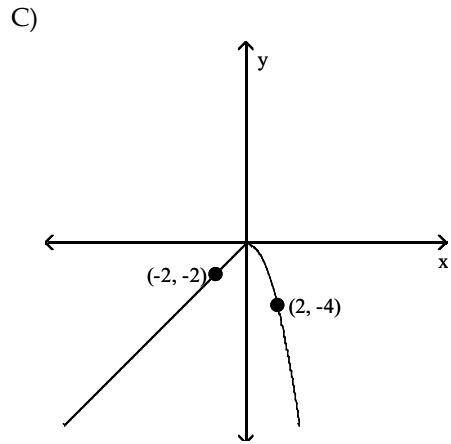
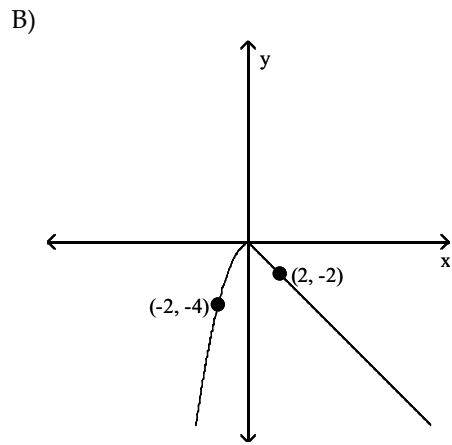
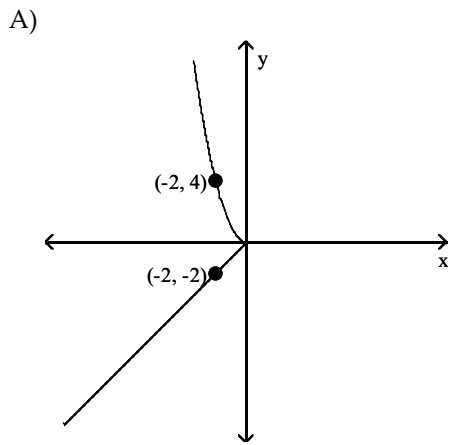

Answer: D

432) Sketch the graph of $y = f(-x)$.

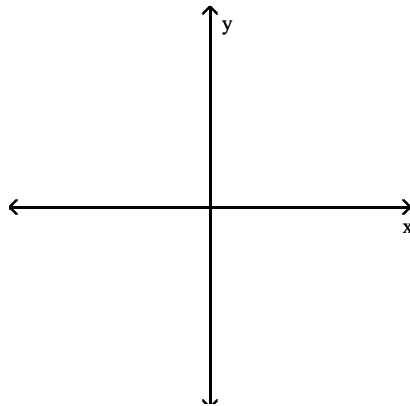
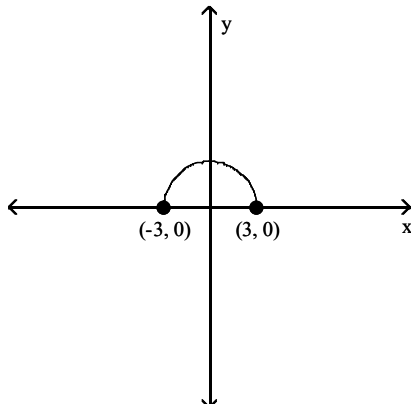

A)

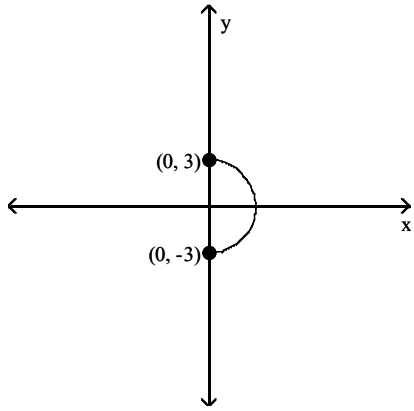

B)

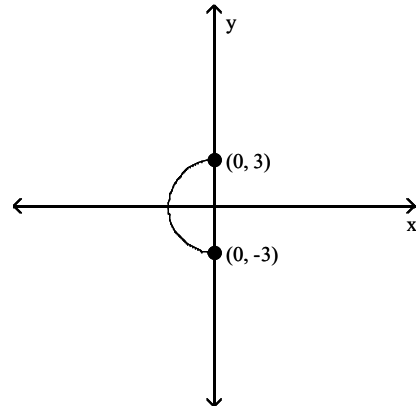

C)

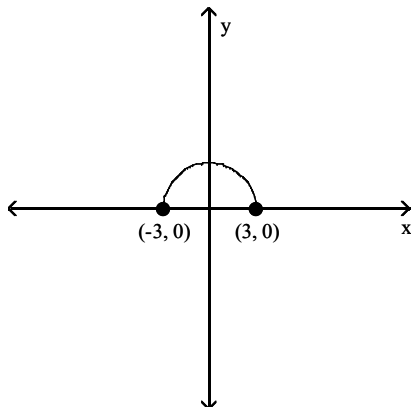

D)

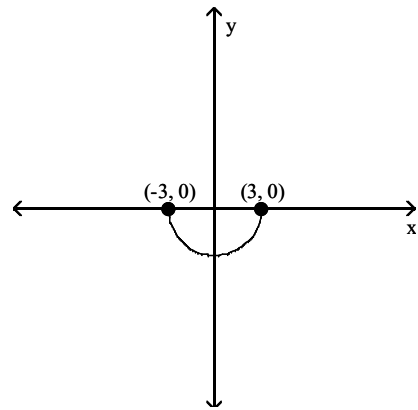

Answer: C

433) Sketch the graph of $y = -f(x)$.

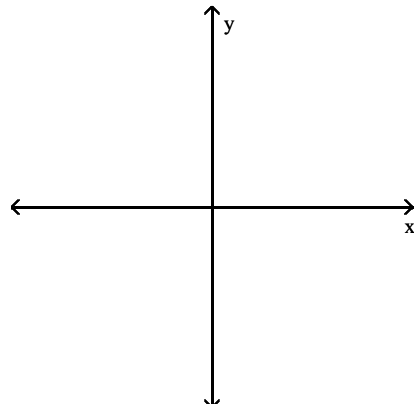
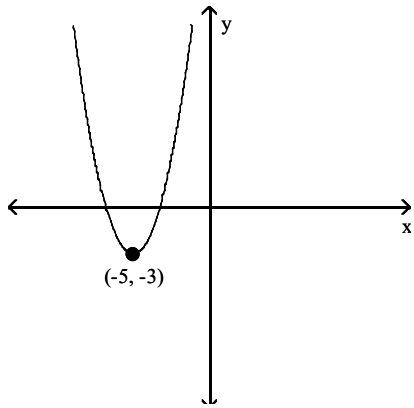

A)

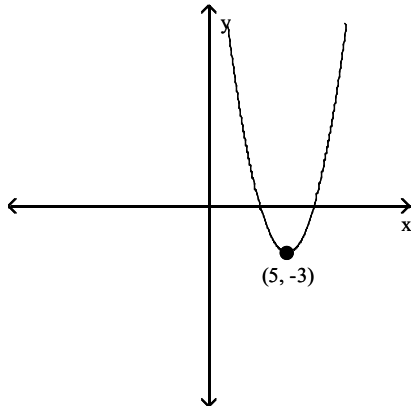

B)

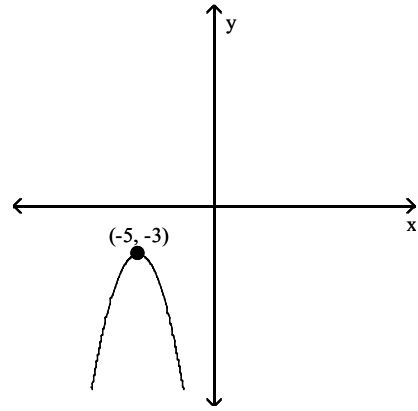

C)

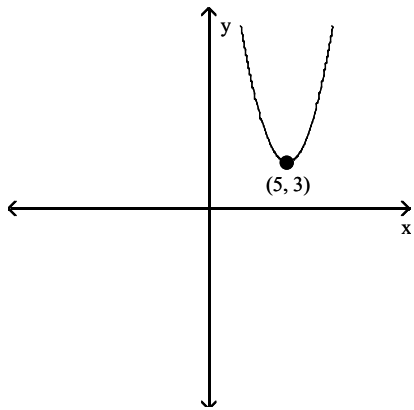

D)

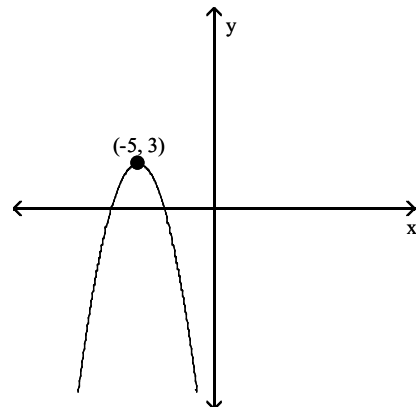

Answer: D

434) Sketch the graph of $y = 2f(x)$.

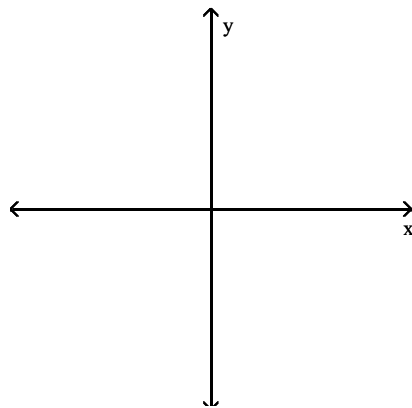
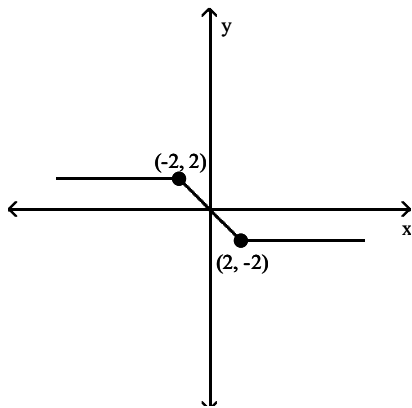

A)

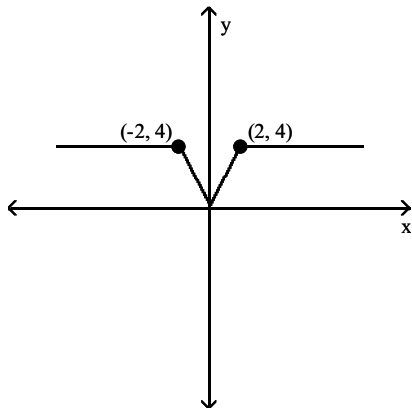

B)

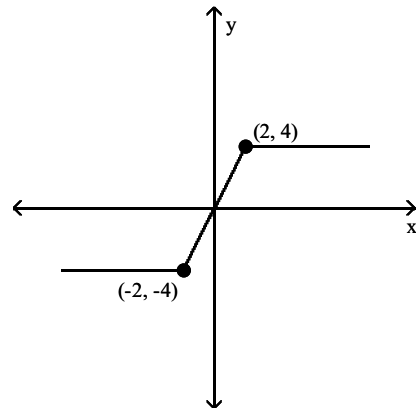

C)

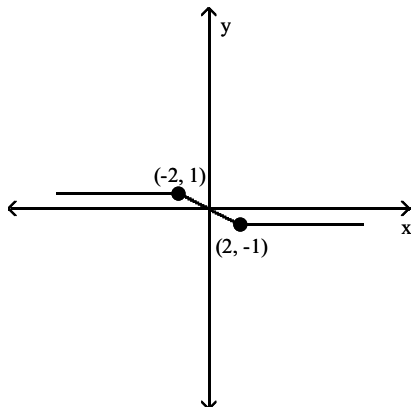

D)

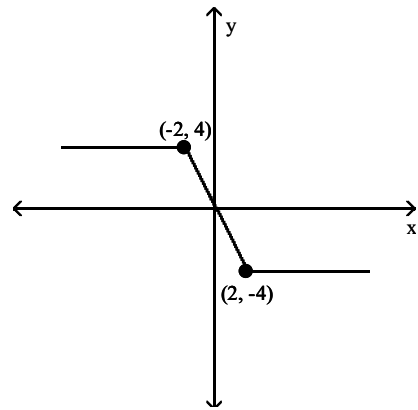

Answer: D

435) Sketch the graph of $y = -\frac{1}{2}f(x)$.

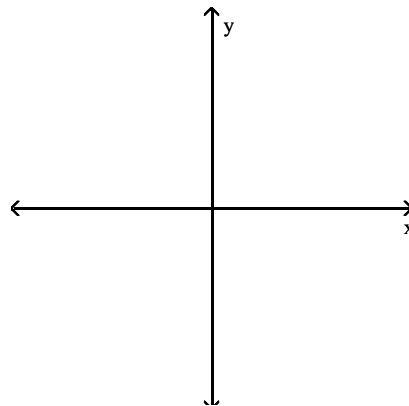
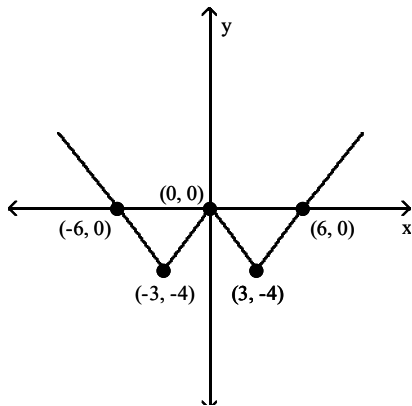

A)

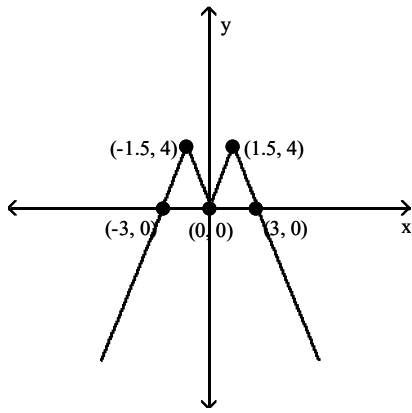

B)

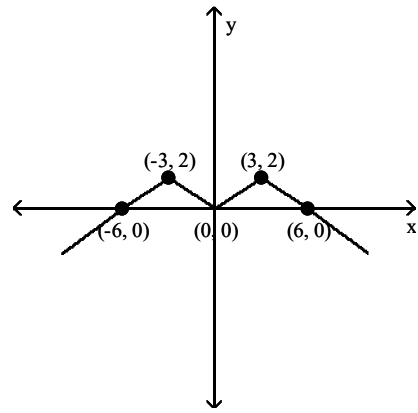

C)

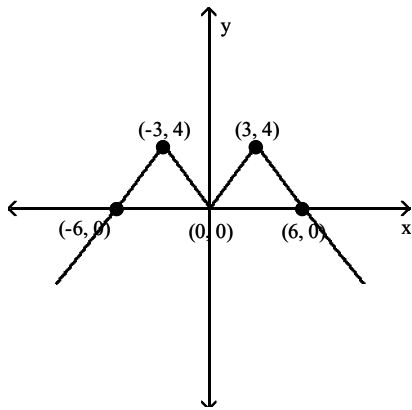

D)

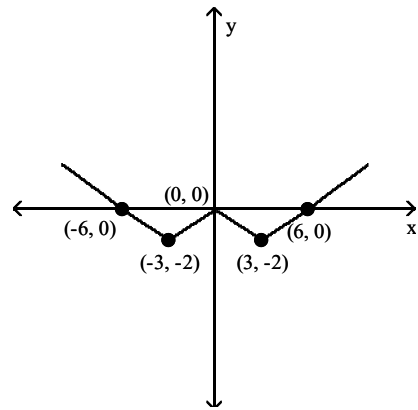

Answer: B

436) Sketch the graph of $y = f(x - 3)$.

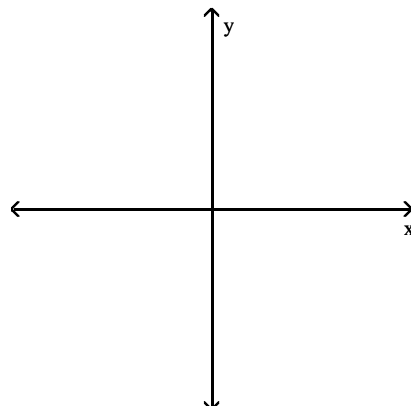
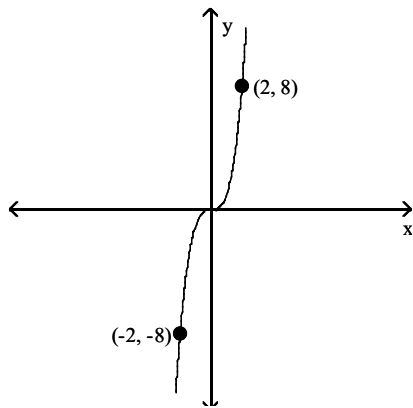

A)

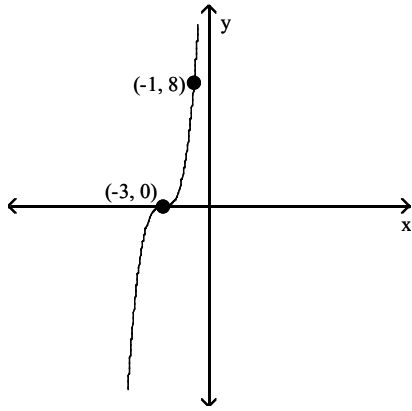

B)

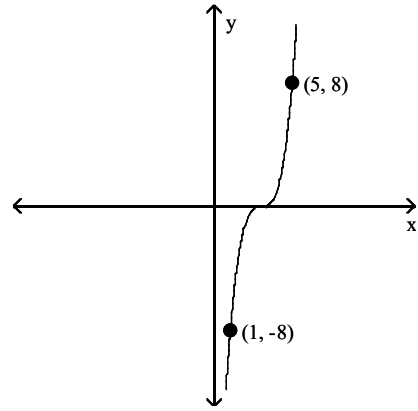

C)

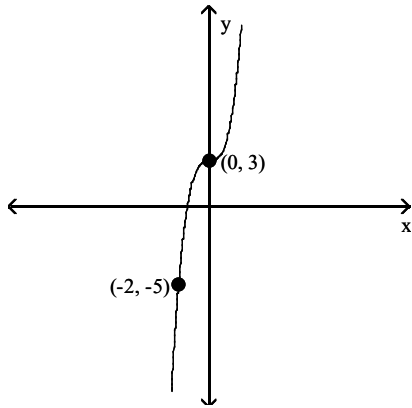

D)

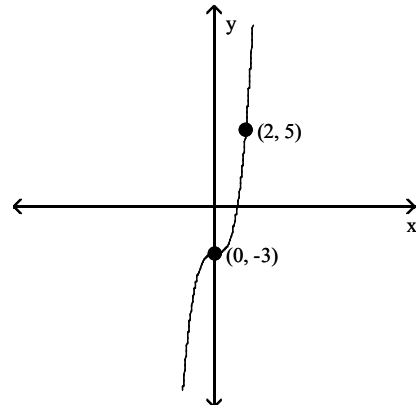

Answer: B

Graph the point symmetric to the given point.

437) Plot the point $(3, 8)$, then plot the point that is symmetric to $(3, 8)$ with respect to the x -axis.

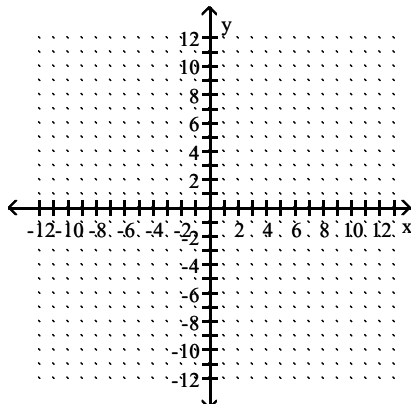

A)

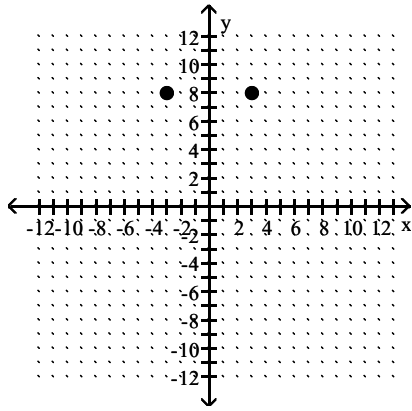

B)

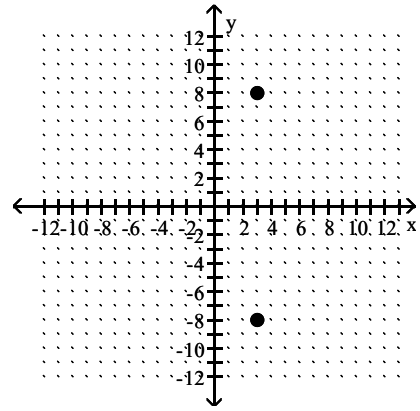

C)

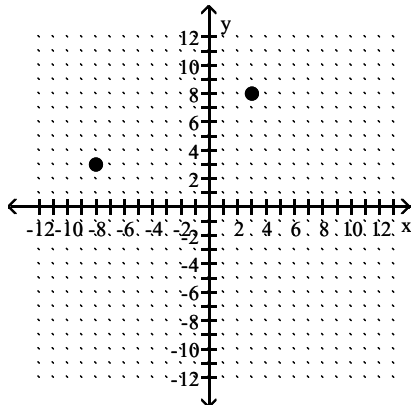

D)

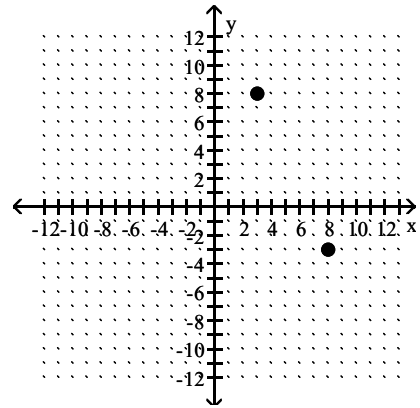

Answer: B

438) Plot the point $(-6, -9)$, then plot the point that is symmetric to $(-6, -9)$ with respect to the x -axis.

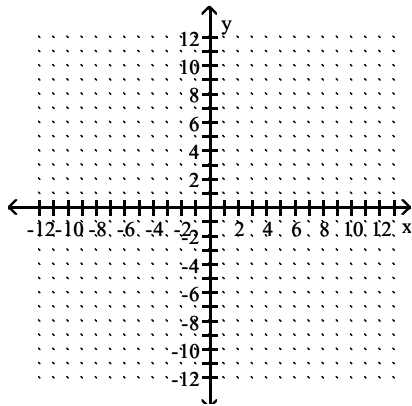

A)

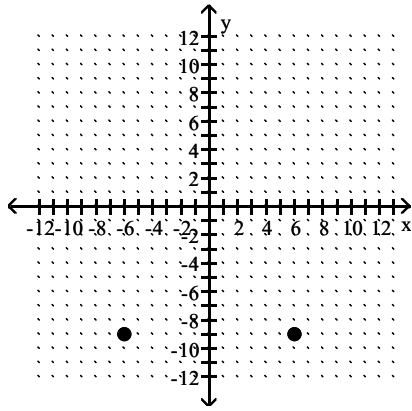

B)

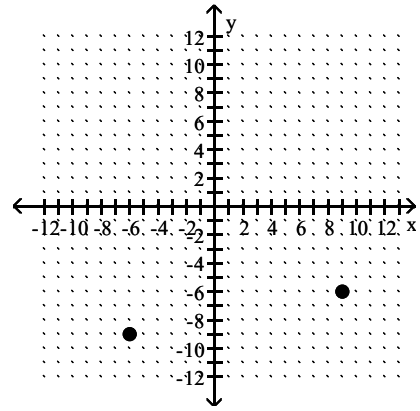

C)

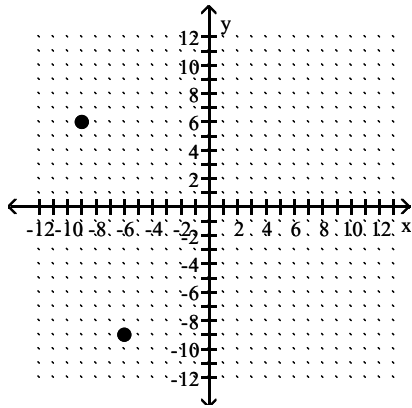

D)

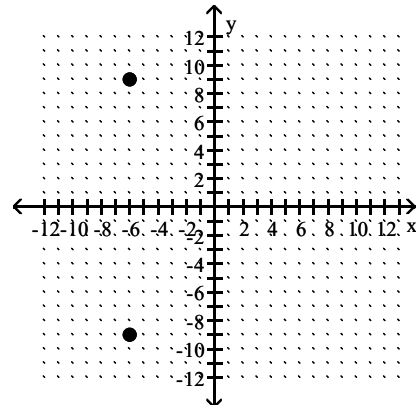

Answer: D

439) Plot the point $(-8, 0)$, then plot the point that is symmetric to $(-8, 0)$ with respect to the x -axis.

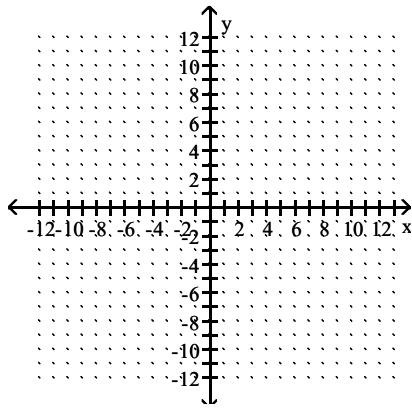

A)

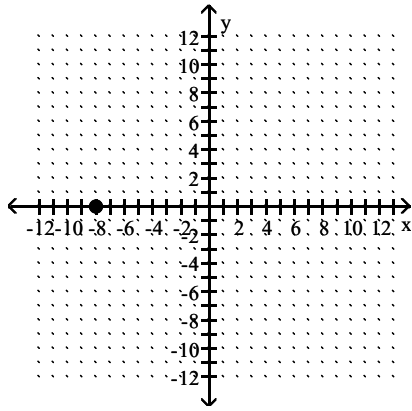

B)

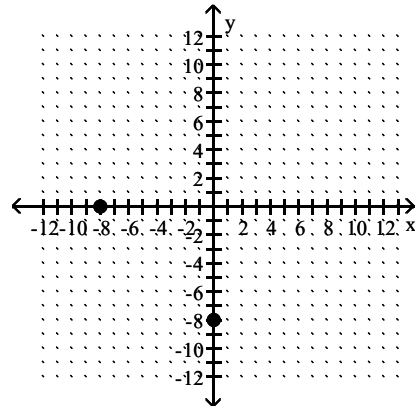

C)

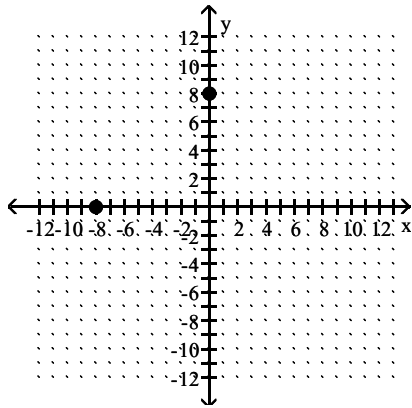

D)

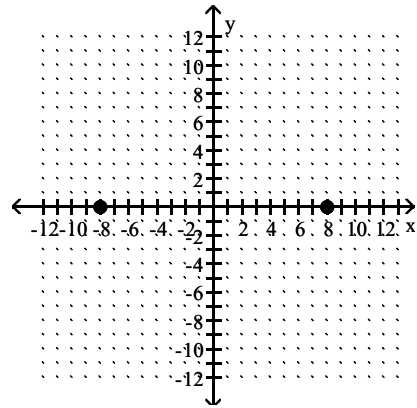

Answer: A

440) Plot the point $(1, 2)$, then plot the point that is symmetric to $(1, 2)$ with respect to the y -axis.

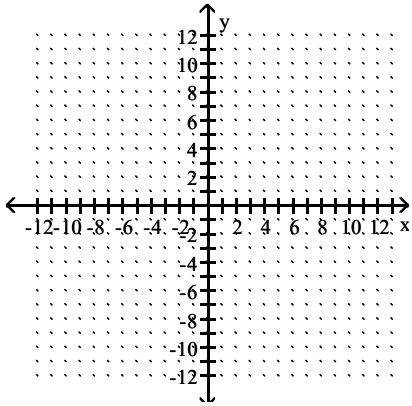

A)

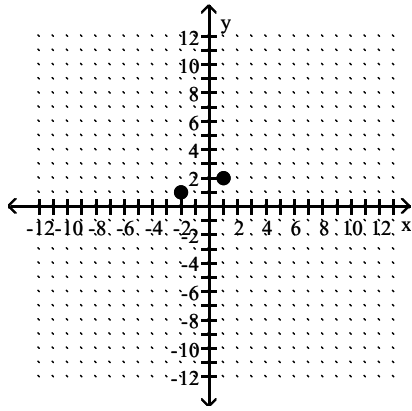

B)

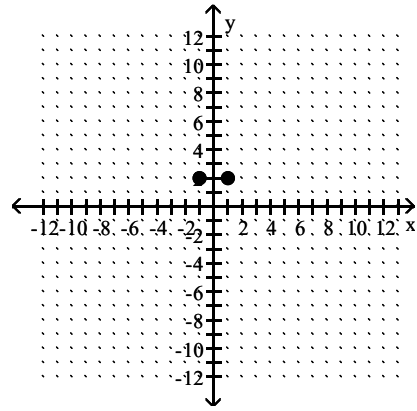

C)

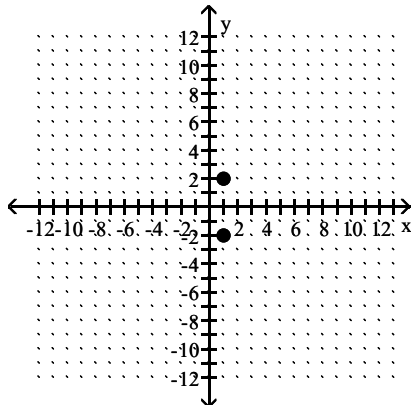

D)

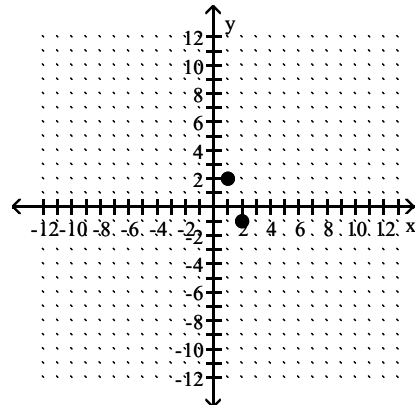

Answer: B

441) Plot the point $(-2, 9)$, then plot the point that is symmetric to $(-2, 9)$ with respect to the y -axis.

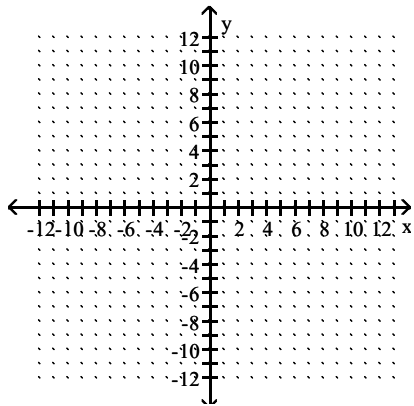

A)

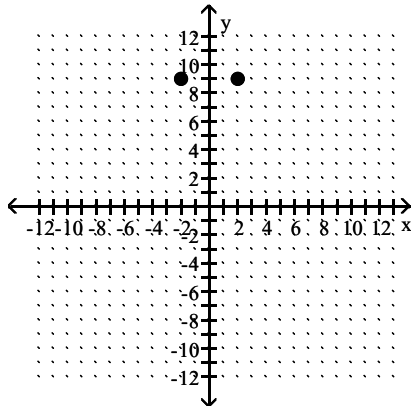

B)

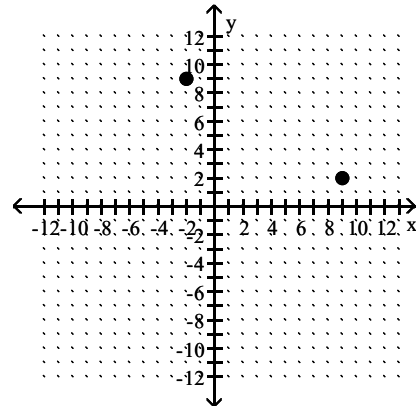

C)

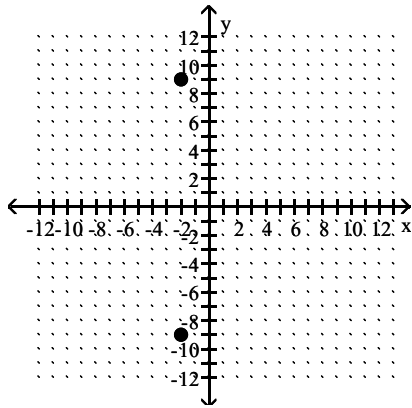

D)

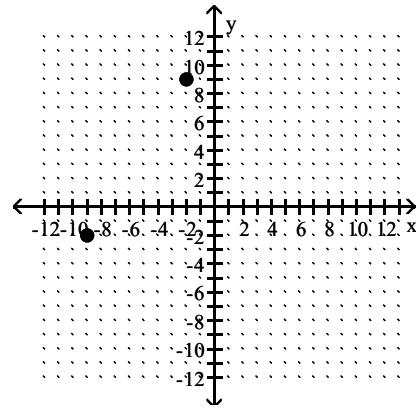

Answer: A

442) Plot the point $(7, 0)$, then plot the point that is symmetric to $(7, 0)$ with respect to the y -axis.

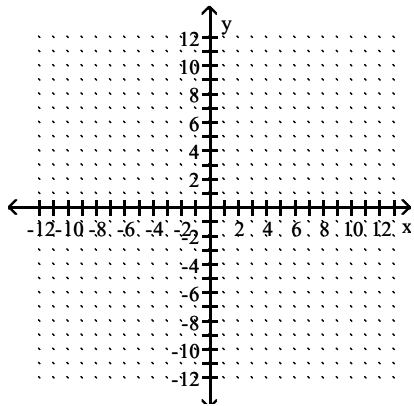

A)

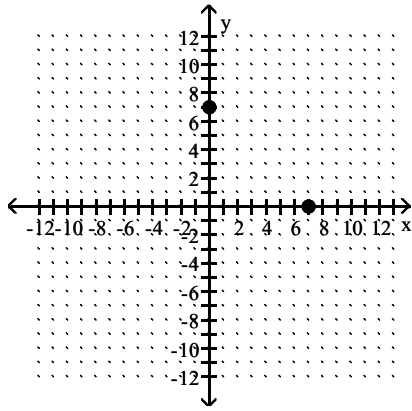

B)

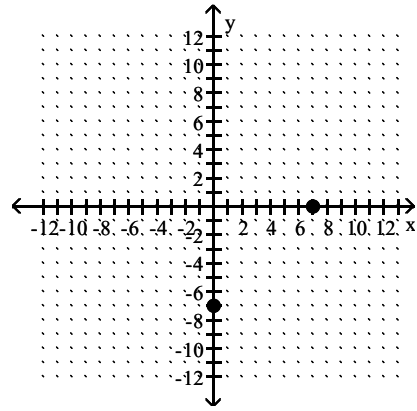

C)

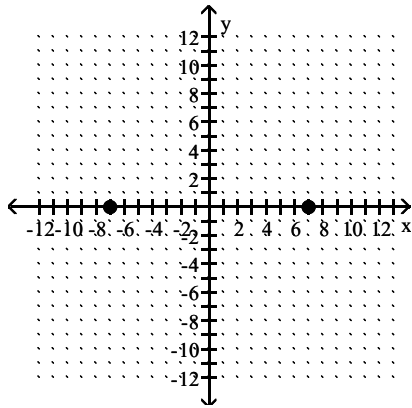

D)

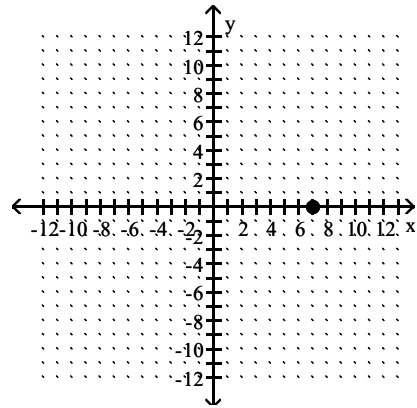

Answer: C

443) Plot the point $(0, -7)$, then plot the point that is symmetric to $(0, -7)$ with respect to the y -axis.

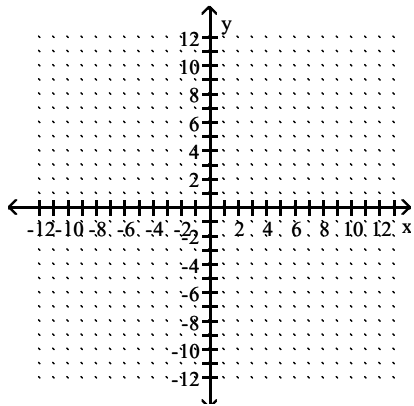

A)

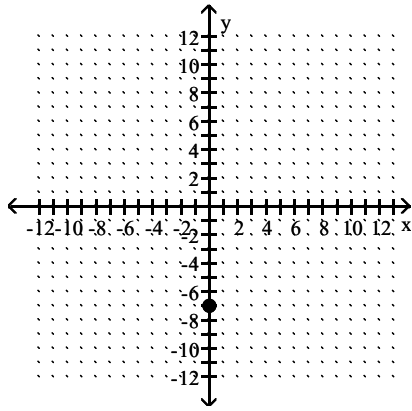

B)

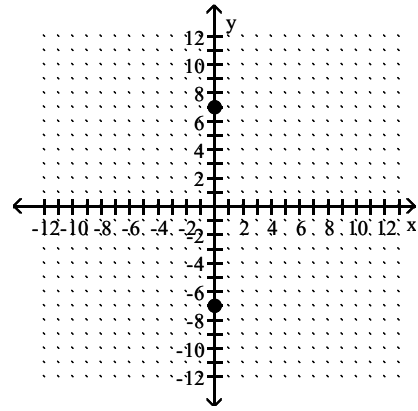

C)

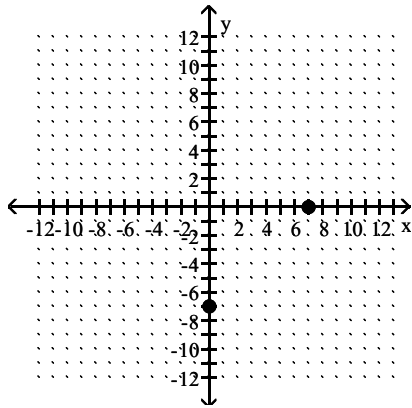

D)

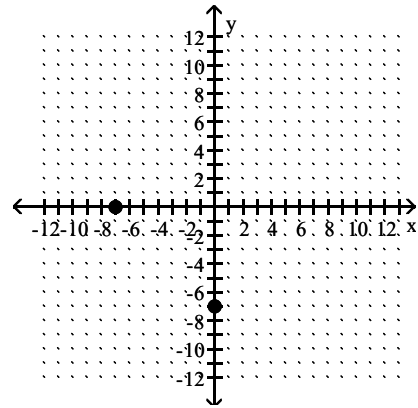

Answer: A

444) Plot the point $(10, 7)$, then plot the point that is symmetric to $(10, 7)$ with respect to the origin.

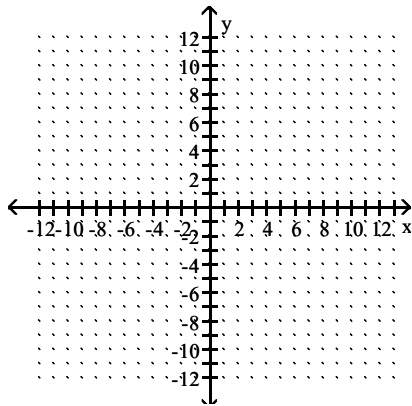

A)

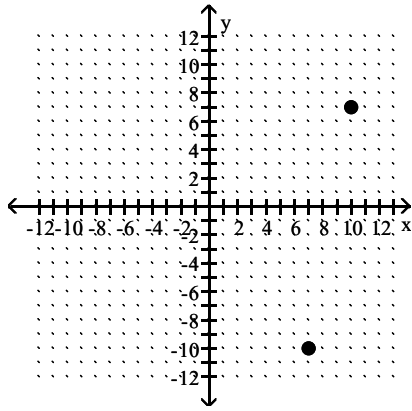

B)

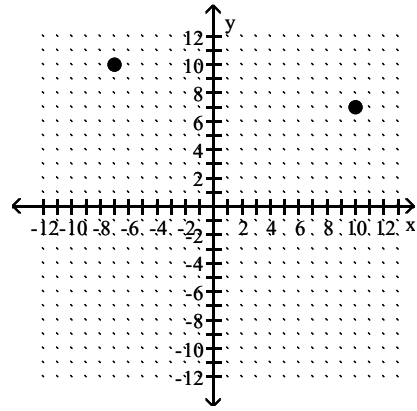

C)

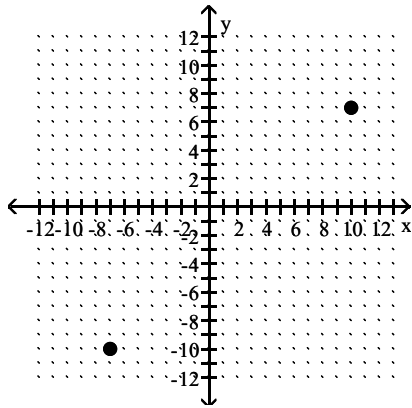

D)

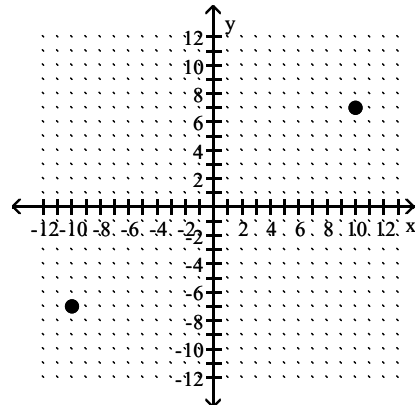

Answer: D

445) Plot the point $(9, -6)$, then plot the point that is symmetric to $(9, -6)$ with respect to the origin.

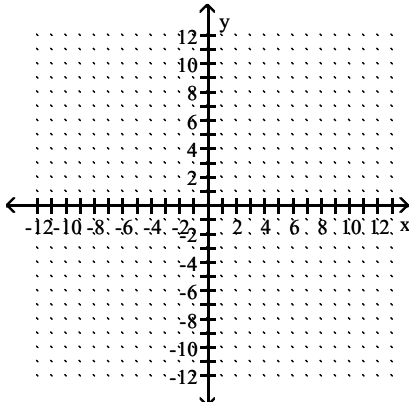

A)

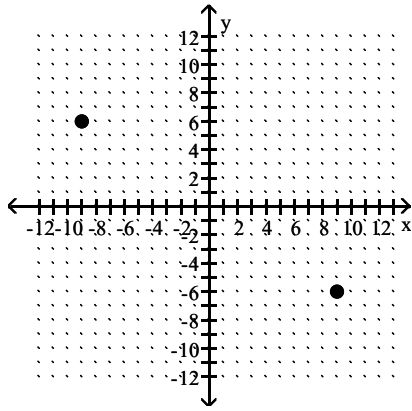

B)

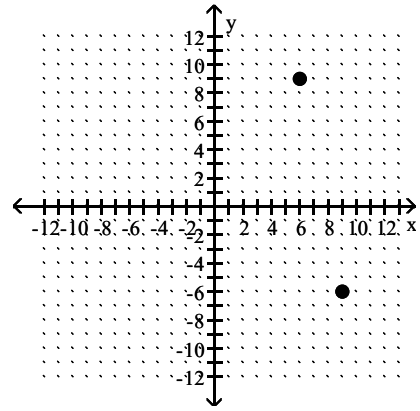

C)

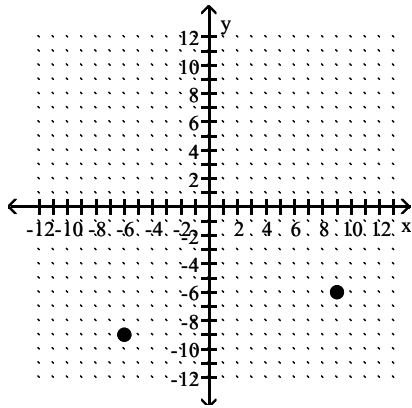

D)

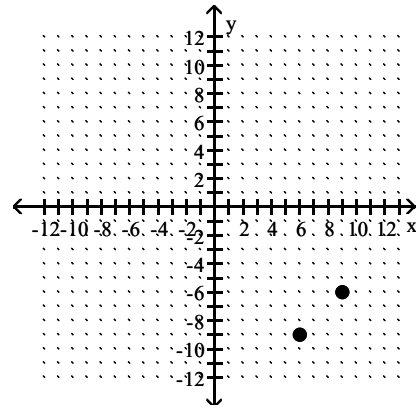

Answer: A

446) Plot the point $(6, 0)$, then plot the point that is symmetric to $(6, 0)$ with respect to the origin.

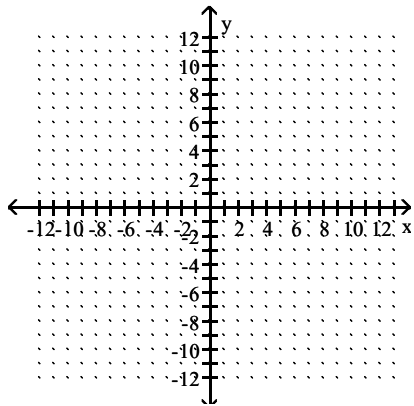

A)

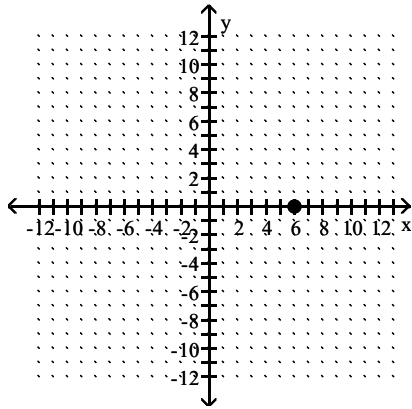

B)

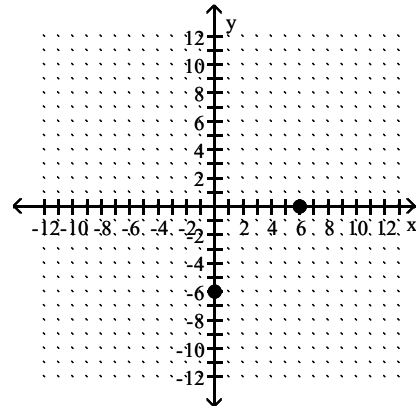

C)

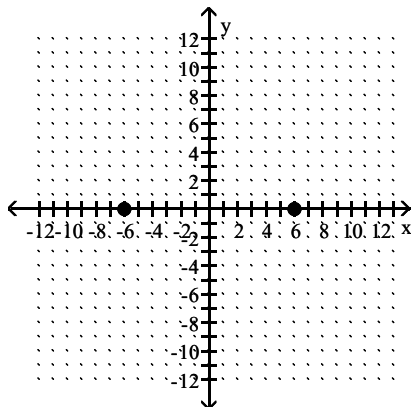

D)

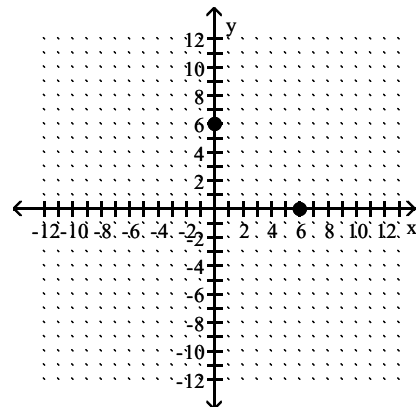

Answer: C

Determine whether the equation has a graph that is symmetric with respect to the y-axis, the x-axis, the origin, or none of these.

447) $y = 3x^2 + 4$

- A) y-axis only
- C) x-axis only

- B) origin only
- D) x-axis, y-axis, origin

Answer: A

448) $y = (x - 6)(x - 6)$

- A) x-axis, y-axis, origin
- C) none of these

- B) x-axis only
- D) y-axis only

Answer: C

449) $y = -6x^3 + 2x$

- A) y-axis only
- C) x-axis, y-axis, origin

- B) origin only
- D) x-axis only

Answer: B

450) $y = 7x^5 - 9x^3$

- A) x-axis, y-axis, origin
- C) y-axis only

- B) none of these
- D) origin only

Answer: D

451) $x^2 - y^2 = 4$
A) x-axis, y-axis
C) y-axis, origin
Answer: D

B) origin only
D) x-axis, y-axis, origin

452) $y = 0.11x^4 + x^2 + 6$
A) x-axis only
Answer: B

B) y-axis only

C) none of these

D) origin only

453) $y = -6x^4 - 5x + 5$
A) none of these
Answer: A

B) origin only

C) y-axis only

D) x-axis only

Determine if the function is even, odd, or neither.

454) $f(x) = 3x^2 + 1$
A) Neither
Answer: B

B) Even

C) Odd

455) $f(x) = x^4 - 2x^2 - 4$
A) Odd
Answer: B

B) Even

C) Neither

456) $f(x) = -4x^3 + 9x$
A) Odd
Answer: A

B) Neither

C) Even

457) $f(x) = 5x^5 + 3x^3$
A) Neither
Answer: C

B) Even

C) Odd

458) $f(x) = -8x^4 + 6x + 3$
A) Neither
Answer: A

B) Odd

C) Even

459) $f(x) = -8x^3 + 5x^2 - 2$
A) Odd
Answer: C

B) Even

C) Neither

460) $f(x) = 0.5x^2 + |x| + 3$
A) Odd
Answer: B

B) Even

C) Neither

Describe the transformations and give the equation for the graph.

461)

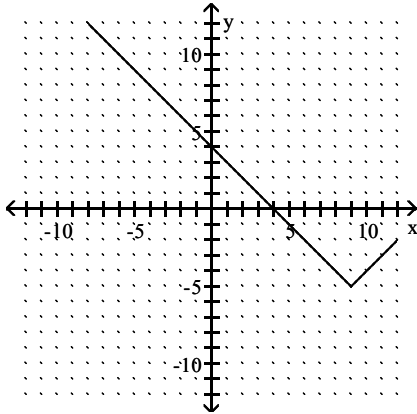

- A) It is the graph of $f(x) = |x|$ translated 9 units to the right and 5 units down. The equation is $y = |x + 9| + 5$
- B) It is the graph of $f(x) = |x|$ translated 9 units to the right and 5 units down. The equation is $y = |x - 9| - 5$
- C) It is the graph of $f(x) = |x|$ translated 9 units to the right and 5 units down. The equation is $y = |x - 9| + 5$
- D) It is the graph of $f(x) = |x|$ translated 9 units to the right and 5 units down. The equation is $y = |x + 9| - 5$

Answer: B

462)

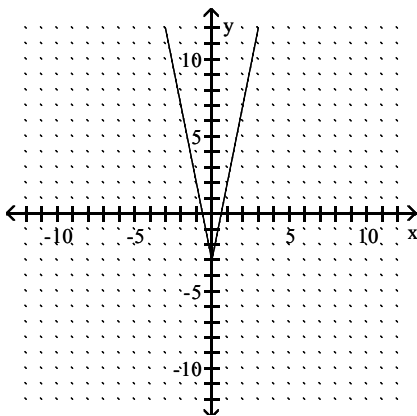

- A) It is the graph of $f(x) = |x|$ shrunken vertically by a factor of 5 and translated 3 units down. The equation is $y = 5|x| + 3$
- B) It is the graph of $f(x) = |x|$ shrunken vertically by a factor of 5 and translated 3 units down. The equation is $y = \frac{1}{5}|x| - 3$
- C) It is the graph of $f(x) = |x|$ stretched vertically by a factor of 5 and translated 3 units down. The equation is $y = \frac{1}{5}|x| + 3$
- D) It is the graph of $f(x) = |x|$ stretched vertically by a factor of 5 and translated 3 units down. The equation is $y = 5|x| - 3$

Answer: D

463)

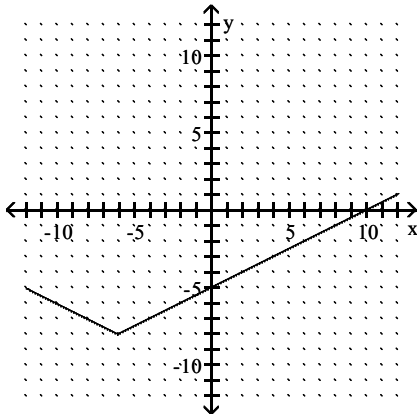

- A) It is the graph of $f(x) = |x|$ translated 6 units to the left, stretched vertically by a factor of 2 and translated 8 units down. The equation is $y = 2|x - 6| + 8$
- B) It is the graph of $f(x) = |x|$ translated 6 units to the left, stretched vertically by a factor of 2 and translated 8 units down. The equation is $y = 2|x + 6| - 8$
- C) It is the graph of $f(x) = |x|$ translated 6 units to the left, shrunk vertically by a factor of $\frac{1}{2}$ and translated 8 units down. The equation is $y = \frac{1}{2}|x - 6| - 8$
- D) It is the graph of $f(x) = |x|$ translated 6 units to the left, shrunk vertically by a factor of $\frac{1}{2}$ and translated 8 units down. The equation is $y = \frac{1}{2}|x + 6| - 8$

Answer: D

464)

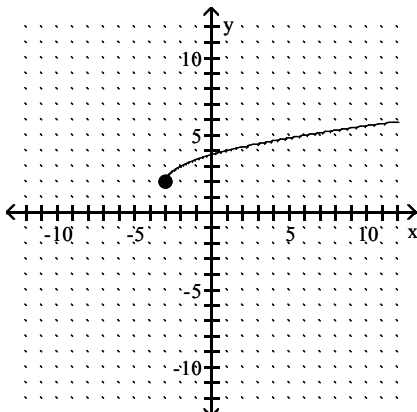

- A) It is the graph of $f(x) = \sqrt{x}$ translated 3 units to the left and translated 2 units up. The equation is $y = \sqrt{x - 3} - 2$
- B) It is the graph of $f(x) = \sqrt{x}$ translated 3 units to the left and translated 2 units up. The equation is $y = \sqrt{x + 3} + 2$
- C) It is the graph of $f(x) = \sqrt{x}$ translated 3 units to the left and translated 2 units up. The equation is $y = \sqrt{x + 3} - 2$
- D) It is the graph of $f(x) = \sqrt{x}$ translated 3 units to the left and translated 2 units up. The equation is $y = \sqrt{x - 3} + 2$

Answer: B

465)

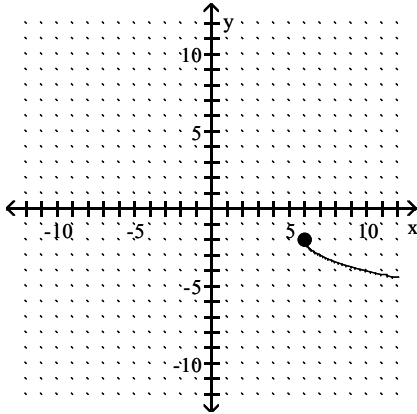

- A) It is the graph of $f(x) = \sqrt{x}$ translated 6 units to the right, reflected across the x-axis and translated 2 units down. The equation is $y = -\sqrt{x+6} - 2$
- B) It is the graph of $f(x) = \sqrt{x}$ translated 6 units to the right, reflected across the x-axis and translated 2 units down. The equation is $y = -\sqrt{x-6} - 2$
- C) It is the graph of $f(x) = \sqrt{x}$ translated 6 units to the right, reflected across the x-axis and translated 2 units down. The equation is $y = \sqrt{-x+6} - 2$
- D) It is the graph of $f(x) = \sqrt{x}$ translated 6 units to the right, reflected across the y-axis and translated 2 units down. The equation is $y = \sqrt{-x-6} - 2$

Answer: B

466)

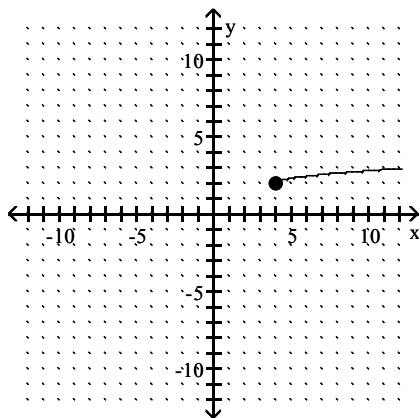

- A) It is the graph of $f(x) = \sqrt{x}$ translated 4 units to the right, stretched vertically by a factor of 3 and translated 2 units up. The equation is $y = 3\sqrt{x+4} + 2$
- B) It is the graph of $f(x) = \sqrt{x}$ translated 4 units to the right, shrunk vertically by a factor of $\frac{1}{3}$ and translated 2 units up. The equation is $y = \frac{1}{3}\sqrt{x-4} + 2$
- C) It is the graph of $f(x) = \sqrt{x}$ translated 4 units to the right, stretched vertically by a factor of 3 and translated 2 units up. The equation is $y = 3\sqrt{x-4} + 2$
- D) It is the graph of $f(x) = \sqrt{x}$ translated 4 units to the right, shrunk vertically by a factor of $\frac{1}{3}$ and translated 2 units up. The equation is $y = \frac{1}{3}\sqrt{x+4} + 2$

Answer: B

Evaluate.

467) Find $(f - g)(-4)$ when $f(x) = 3x^2 + 1$ and $g(x) = x + 5$.

- A) 58 B) -45 C) 40 D) 48

Answer: D

468) Find $(f + g)(-1)$ when $f(x) = x + 5$ and $g(x) = x + 4$.

- A) -3 B) -11 C) -1 D) 7

Answer: D

469) Find $\left(\frac{f}{g}\right)(-4)$ when $f(x) = 4x - 3$ and $g(x) = 2x^2 + 14x + 4$.

- A) $\frac{2}{13}$ B) $-\frac{1}{5}$ C) $-\frac{1}{10}$ D) $\frac{19}{20}$

Answer: D

470) Find $(fg)(-2)$ when $f(x) = x + 1$ and $g(x) = -5x^2 + 11x + 4$.

- A) 14 B) 114 C) 38 D) 48

Answer: C

For the pair of functions, find the indicated sum, difference, product, or quotient.

471) $f(x) = 7x - 5$, $g(x) = 5x - 8$

Find $(f - g)(x)$.

A) $2x - 13$

B) $12x - 13$

C) $2x + 3$

D) $-2x - 3$

Answer: C

472) $f(x) = 6 - 7x$, $g(x) = -9x + 7$

Find $(f + g)(x)$.

A) $-3x$

B) $-9x + 6$

C) $-16x + 13$

D) $2x + 13$

Answer: C

473) $f(x) = 2 - 9x$, $g(x) = -5x^2 + 9$

Find $(f + g)(x)$.

A) $-5x^2 - 9x + 11$

B) $-14x + 11$

C) $-5x^2 + 2$

D) $-14x^2 - 9x + 11$

Answer: A

474) $f(x) = 4x^2 - 7x$, $g(x) = x^2 - 5x - 14$

Find $\left(\frac{f}{g}\right)(x)$.

A) $\frac{4 - x}{14}$

B) $\frac{4x}{x + 1}$

C) $\frac{4x^2 - 7x}{x^2 - 5x - 14}$

D) $\frac{4x - 7}{-5}$

Answer: C

475) $f(x) = 7x - 2$, $g(x) = 8x + 6$

Find $(fg)(x)$.

A) $56x^2 - 10x - 12$

B) $15x^2 + 26x + 4$

C) $56x^2 - 12$

D) $56x^2 + 26x - 12$

Answer: D

476) $f(x) = x^2 + 1$, $g(x) = 9x + 5$

Find $(fg)(x)$.

A) $9x^2 + 9x + 5$

B) $9x^3 + 5x^2 + 9x + 5$

C) $9x^3 + 9x^2 + 5x + 5$

D) $9x^3 + 5$

Answer: B

477) $f(x) = \sqrt{2x + 2}$, $g(x) = \sqrt{9x - 25}$

Find $(fg)(x)$.

A) $(\sqrt{2x + 2})(\sqrt{9x - 25})$

B) $(2x + 2)(9x - 25)$

C) $(3x - 5)(\sqrt{2x + 2})$

D) $(2x + 2)(3x - 5)$

Answer: A

478) $f(x) = \sqrt{3x + 3}$, $g(x) = \frac{1}{x}$

Find $\left(\frac{f}{g}\right)(x)$.

A) $\frac{1}{x\sqrt{3x + 3}}$

B) $\frac{x}{\sqrt{3x + 3}}$

C) $\frac{\sqrt{3x + 3}}{x}$

D) $x\sqrt{3x + 3}$

Answer: D

479) $f(x) = \sqrt{7x + 4}$, $g(x) = \frac{1}{x}$

Find $(f - g)(x)$.

A) $\frac{1}{x} - \sqrt{7x + 4}$

B) $\sqrt{7x + 4} - \frac{1}{x}$

C) $\frac{1}{\sqrt{7x + 4} - x}$

D) $\sqrt{7x + 4} - \frac{1}{x}$

Answer: B

Find the specified domain.

480) Find the domain of $(f - g)(x)$ when $f(x) = 6x - 9$ and $g(x) = 6x - 5$.

A) $(-6, \infty)$

B) $(-\infty, \infty)$

C) $(-9, 6)$

D) $(-6, 9)$

Answer: B

481) Find the domain of $(fg)(x)$ when $f(x) = \sqrt{6x + 9}$ and $g(x) = \sqrt{7x - 9}$.

A) $\left[\frac{9}{7}, \infty\right)$

B) $\left[-\frac{9}{7}, \infty\right)$

C) $[0, \infty)$

D) $(-\infty, \infty)$

Answer: A

482) Find the domain of $(f + g)(x)$ when $f(x) = \sqrt{3x - 9}$ and $g(x) = \frac{1}{x}$

A) $(-\infty, 0) \cup (0, \infty)$

B) $[-3, 0) \cup (0, \infty)$

C) $[3, \infty)$

D) $[-3, \infty)$

Answer: C

483) Find the domain of $\left(\frac{f}{g}\right)(x)$ when $f(x) = \sqrt{4x - 6}$ and $g(x) = \frac{1}{x}$

A) $\left[-\frac{3}{2}, \infty\right)$

B) $\left[\frac{3}{2}, \infty\right)$

C) $(-\infty, 0) \cup (0, \infty)$

D) $\left[-\frac{3}{2}, 0\right) \cup (0, \infty)$

Answer: B

484) Find the domain of $(f + g)(x)$ when $f(x) = 5x - 10$ and $g(x) = \frac{2}{x - 5}$

A) $(-\infty, \infty)$

B) $(-\infty, 5) \cup (5, \infty)$

C) $(-\infty, -5) \cup (-5, \infty)$

D) $(-\infty, -2) \cup (-2, \infty)$

Answer: B

485) Find the domain of $(f - g)(x)$ when $f(x) = \frac{2x}{x - 5}$ and $g(x) = \frac{5}{x + 1}$

A) $(-\infty, -1) \cup (-1, 5) \cup (5, \infty)$

B) $(-\infty, -5) \cup (-5, -2) \cup (-2, \infty)$

C) $(-\infty, \infty)$

D) $(-\infty, -5) \cup (-5, 1) \cup (1, \infty)$

Answer: A

486) Find the domain of $(fg)(x)$ when $f(x) = \frac{2}{x - 12}$ and $g(x) = -4x - 5$

A) $(-\infty, -12) \cup (-12, \infty)$

B) $(-\infty, 5) \cup (5, \infty)$

C) $(-\infty, \infty)$

D) $(-\infty, 12) \cup (12, \infty)$

Answer: D

487) Find the domain of $\left(\frac{f}{g}\right)(x)$ when $f(x) = 2x - 6$ and $g(x) = 5x - 2$

A) $(-\infty, 3) \cup (3, \infty)$

B) $\left(-\infty, \frac{2}{5}\right) \cup \left(\frac{2}{5}, \infty\right)$

C) $(-\infty, \infty)$

D) $\left(-\infty, \frac{2}{5}\right) \cup \left(\frac{2}{5}, 3\right) \cup (3, \infty)$

Answer: B

488) Find the domain of $\left(\frac{f}{g}\right)(x)$ when $f(x) = 2x - 5$ and $g(x) = \frac{2}{x - 8}$

A) $\left(-\infty, \frac{5}{2}\right) \cup \left(\frac{5}{2}, 8\right) \cup (8, \infty)$

B) $(-\infty, \infty)$

C) $(-\infty, 8) \cup (8, \infty)$

D) $(-\infty, -8) \cup (-8, \infty)$

Answer: C

489) Find the domain of $\left(\frac{f}{g}\right)(x)$ when $f(x) = \frac{5}{x - 3}$ and $g(x) = 7 - x$

A) $(-\infty, 3) \cup (3, \infty)$

B) $(-\infty, -7) \cup (-7, -3) \cup (-3, \infty)$

C) $(-\infty, 7) \cup (7, \infty)$

D) $(-\infty, 3) \cup (3, 7) \cup (7, \infty)$

Answer: D

Solve the problem.

490) The graphs of functions f and g are shown. Use these graphs to find $(f + g)(-2)$.

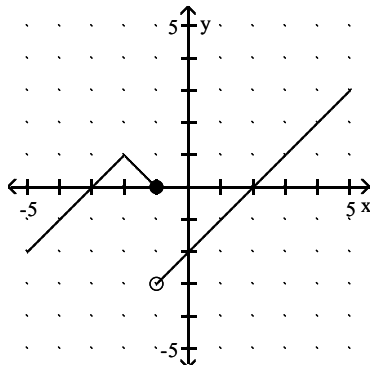

$y = f(x)$

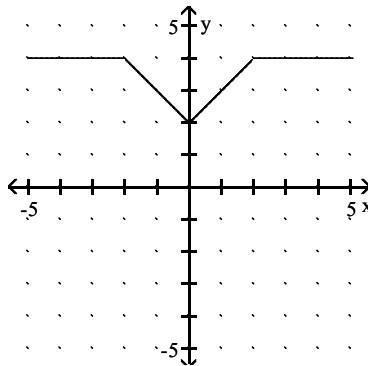

$y = g(x)$

A) -3

B) $\frac{1}{4}$

C) 5

D) 4

Answer: C

491) The graphs of functions f and g are shown. Use these graphs to find $(fg)(1)$.

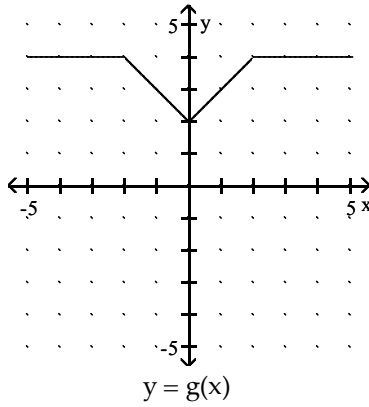
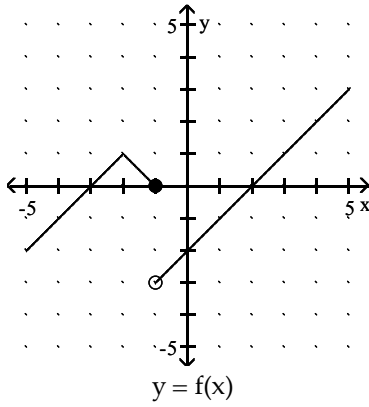

A) -3

B) 2

C) -4

D) 3

Answer: A

492) Use the graphs to find the value of $(f + g)(3)$.

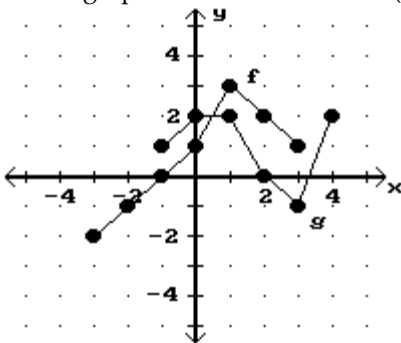

A) 0

B) 1

C) 3

D) -1

Answer: A

493) Use the graphs to find the value of $(f - g)(-1)$.

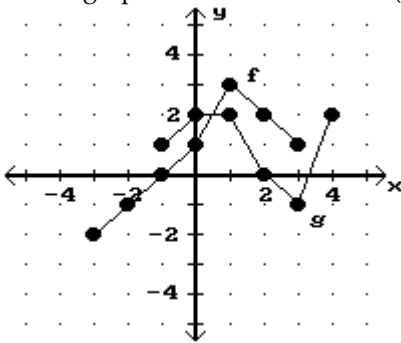

A) -1

B) 0

C) 3

D) 1

Answer: A

494) Use the graphs to find the value of $(fg)(1)$.

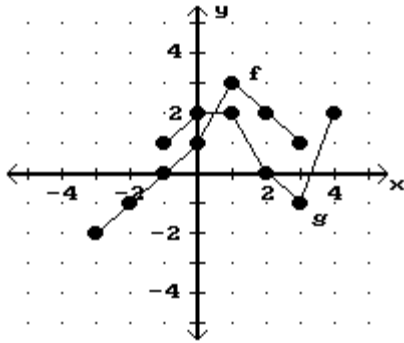

A) 4

B) 3

C) 2

D) 6

Answer: D

495) Use the graphs to find the value of $\left(\frac{f}{g}\right)(3)$.

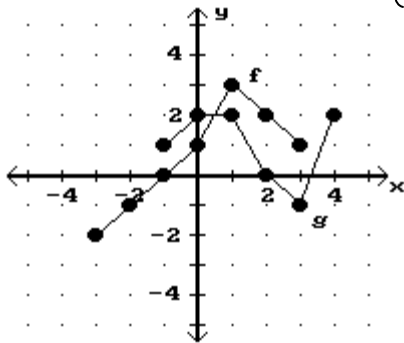

A) 1

B) -1

C) -2

D) undefined

Answer: B

496) Use the tables to find $(f + g)(-2)$.

x	-2	4	7
f(x)	-1	-6	-4

x	-2	5	7
g(x)	1	-1	5

A) 14

B) 1

C) 0

D) -7

Answer: C

497) Use the tables to find $(fg)(1)$.

x	1	2	5
f(x)	-6	5	-9

x	1	4	5
g(x)	9	-4	-8

A) -54

B) -20

C) 1

D) 72

Answer: A

Compute and simplify the difference quotient $\frac{f(x+h) - f(x)}{h}$, $h \neq 0$.

498) $f(x) = 4x - 9$

A) 4

B) $\frac{9}{4}$

C) $-9h$

D) 9

Answer: A

499) $f(x) = \frac{20}{x+15}$

A) $-\frac{20}{(x+20)^2}$

B) $-\frac{20}{(x+h+15)(x+15)}$

C) $\frac{20}{(x+h+15)(x+15)}$

D) $-\frac{300}{(x+h+15)(x+15)}$

Answer: B

500) $f(x) = 6x^2 + 5x$

A) $12x + 6h + 5$

B) $12x + 5$

C) $12x^2 + 6h + 5x$

D) $18x - 8h + 10$

Answer: A

501) $f(x) = \frac{x}{7-x}$

A) $\frac{7}{(7-x-h)(7-x)}$

B) $-\frac{7}{(7-x+h)(7-x)}$

C) $\frac{hx}{(7-x-h)(7+x)}$

D) $\frac{x}{(7-x+h)(7-x)}$

Answer: A

502) $f(x) = \frac{x-9}{x+3}$

A) $\frac{13}{(x+3)(x-3)}$

B) $-\frac{12}{x(x+3)}$

C) $\frac{12}{(x+h+3)(x+3)}$

D) $\frac{12(x+h+3)}{(x+3)}$

Answer: C

Find the requested function value.

503) Find $(f \circ g)(-9)$ when $f(x) = 9x - 2$ and $g(x) = -4x^2 + 6x + 7$.

A) $-28,047$

B) -3341

C) -101

D) -159

Answer: B

504) Find $(g \circ f)(6)$ when $f(x) = -5x + 5$ and $g(x) = -7x^2 - 4x + 5$.

A) 310

B) 1360

C) -4270

D) 280

Answer: C

505) Find $(g \circ f)(-1)$ when $f(x) = \frac{x-7}{8}$ and $g(x) = 8x + 1$.

A) -9

B) $-\frac{7}{4}$

C) -7

D) 7

Answer: C

Find the requested value.

506) Using the given tables, find $(f \cdot g)(2)$

x	9	5	1	3
f(x)	18	10	2	6

x	4	2	5	3
g(x)	7	3	9	5

A) 10

B) 6

C) 3

D) 2

Answer: B

507) Using the given tables, find $(g \cdot f)(4)$

x	4	7	5	10
f(x)	5	8	19	21

x	6	10	4	5
g(x)	11	7	10	9

A) 9

B) 7

C) 19

D) 4

Answer: A

508) Using the given tables, find $(f \cdot f)(2)$

x	2	5	3	1
f(x)	3	2	7	9

x	4	2	5	3
g(x)	7	3	9	5

A) 2

B) 5

C) 7

D) 9

Answer: C

509) Using the given tables, find $(g \cdot g)(4)$

x	4	7	5	10
f(x)	5	8	19	21

x	6	10	4	5
g(x)	11	7	10	9

A) 19

B) 7

C) 9

D) 21

Answer: B

For the given functions f and g, find the indicated composition.

510) $f(x) = 4x + 15$, $g(x) = 4x - 1$

$(f \cdot g)(x)$

A) $16x + 19$

B) $16x + 59$

C) $16x + 11$

D) $16x + 14$

Answer: C

511) $f(x) = -5x + 8$, $g(x) = 6x + 9$

$(g \cdot f)(x)$

A) $-30x - 39$

B) $30x + 57$

C) $-30x + 53$

D) $-30x + 57$

Answer: D

512) $f(x) = \frac{8}{x+4}$, $g(x) = \frac{6}{5x}$

$(f \cdot g)(x)$

A) $\frac{6x+24}{40x}$

B) $\frac{40x}{6+20x}$

C) $\frac{40x}{6-20x}$

D) $\frac{8x}{6+20x}$

Answer: B

513) $f(x) = \sqrt{x-1}$, $g(x) = -\frac{7}{x}$

$(g \circ f)(x)$

A) $\frac{7}{\sqrt{-x-1}}$

B) $-\frac{1}{\sqrt{7x-1}}$

C) $-\frac{7}{\sqrt{x-1}}$

D) $\sqrt{-\frac{7}{x}-1}$

Answer: C

514) $f(x) = \frac{x-8}{3}$, $g(x) = 3x+8$

$(g \circ f)(x)$

A) $3x+16$

B) $x+16$

C) x

D) $x - \frac{8}{3}$

Answer: C

515) $f(x) = \sqrt{x+8}$, $g(x) = 8x-12$

$(f \circ g)(x)$

A) $2\sqrt{2x+1}$

B) $2\sqrt{2x-1}$

C) $8\sqrt{x-4}$

D) $8\sqrt{x+8}-12$

Answer: B

516) $f(x) = 4x^2 + 5x + 7$, $g(x) = 5x - 6$

$(g \circ f)(x)$

A) $4x^2 + 5x + 1$

B) $20x^2 + 25x + 29$

C) $20x^2 + 25x + 41$

D) $4x^2 + 25x + 29$

Answer: B

Determine whether $(f \circ g)(x) = x$ and whether $(g \circ f)(x) = x$.

517) $f(x) = \sqrt[5]{x-14}$, $g(x) = x^5 + 14$

A) No, no

B) Yes, no

C) Yes, yes

D) No, yes

Answer: C

518) $f(x) = x^2 + 3$, $g(x) = \sqrt{x} - 3$

A) Yes, no

B) No, no

C) No, yes

D) Yes, yes

Answer: B

519) $f(x) = \frac{1}{x}$, $g(x) = x$

A) No, yes

B) Yes, yes

C) No, no

D) Yes, no

Answer: C

520) $f(x) = \sqrt{x+1}$, $g(x) = x^2$

A) Yes, no

B) No, no

C) No, yes

D) Yes, yes

Answer: B

521) $f(x) = x^3 + 8$, $g(x) = \sqrt[3]{x-8}$

A) Yes, yes

B) No, no

C) Yes, no

D) No, yes

Answer: A

Consider the function h as defined. Find functions f and g so that $(f \circ g)(x) = h(x)$.

$$522) h(x) = \frac{1}{x^2 - 6}$$

$$A) f(x) = \frac{1}{x^2}, g(x) = -\frac{1}{6}$$

$$B) f(x) = \frac{1}{x^2}, g(x) = x - 6$$

$$C) f(x) = \frac{1}{6}, g(x) = x^2 - 6$$

$$D) f(x) = \frac{1}{x}, g(x) = x^2 - 6$$

Answer: D

$$523) h(x) = |2x + 4|$$

$$A) f(x) = |x|, g(x) = 2x + 4$$

$$B) f(x) = |-x|, g(x) = 2x - 4$$

$$C) f(x) = x, g(x) = 2x + 4$$

$$D) f(x) = -|x|, g(x) = 2x + 4$$

Answer: A

$$524) h(x) = \frac{3}{x^2} + 8$$

$$A) f(x) = \frac{3}{x^2}, g(x) = 8$$

$$B) f(x) = \frac{1}{x}, g(x) = \frac{3}{x} + 8$$

$$C) f(x) = x, g(x) = \frac{3}{x} + 8$$

$$D) f(x) = x + 8, g(x) = \frac{3}{x^2}$$

Answer: D

$$525) h(x) = \frac{10}{\sqrt{8x + 8}}$$

$$A) f(x) = \frac{10}{x}, g(x) = 8x + 8$$

$$B) f(x) = \sqrt{8x + 8}, g(x) = 10$$

$$C) f(x) = \frac{10}{\sqrt{x}}, g(x) = 8x + 8$$

$$D) f(x) = 10, g(x) = \sqrt{8 + 8}$$

Answer: C

$$526) h(x) = (-8x + 9)^9$$

$$A) f(x) = -8x + 9, g(x) = x^9$$

$$B) f(x) = x^9, g(x) = -8x + 9$$

$$C) f(x) = -8x^9, g(x) = x + 9$$

$$D) f(x) = (-8x)^9, g(x) = 9$$

Answer: B

A new chocolate company is estimating how many candy bars per week college students will consume of their line of products. The graph shows the probable number of candy bars students (age 18–22) will consume from year 0 to year 10. $B(x)$ gives the number of candy bars for boys, $G(x)$ gives the number of candy bars for girls, and $T(x)$ gives the total number for both groups. Use the graph to answer the question.

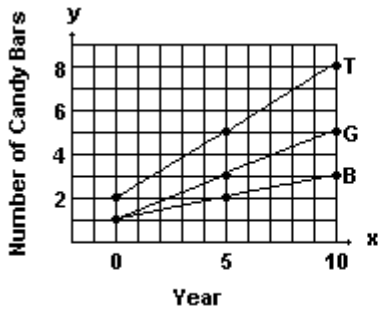

- 527) Estimate $B(4)$ and $G(4)$ and use your estimates to estimate $T(4)$.
 A) 2.0; 3.0; 5.0 B) 1.5; 2.5; 4.0 C) 1.8; 2.5; 4.3 D) 2.0; 2.8; 4.8

Answer: D

- 528) Estimate $B(7)$ and $G(7)$ and use your estimates to estimate $T(7)$.
 A) 3.5; 4.2; 7.7 B) 2.2; 4.3; 6.5 C) 2.5; 4.0; 6.5 D) 2.3; 4.0; 6.3

Answer: B

- 529) Use the slopes of the line segments to decide in which period (0–5 or 5–10) the number of candy bars per week increased more rapidly.
 A) 0–5
 B) The number of candy bars increased at the same rate in both periods
 C) 5–10

Answer: B

Solve the problem.

- 530) The cost of manufacturing clocks is given by $C(x) = 60 + 48x - x^2$. Also, it is known that in t hours the number of clocks that can be produced is given by $x = 6t$, where $1 \leq t \leq 12$. Express C as a function of t .

- A) $C(t) = 60 + 48t - 6$ B) $C(t) = 60 + 288t - 36t^2$
 C) $C(t) = 60 + 48t + t^2$ D) $C(t) = 60 + 288t - 36t$

Answer: B

- 531) The radius r of a circle of known area A is given by $r = \sqrt{A/\pi}$, where $\pi \approx 3.1416$. Find the radius and circumference of a circle with an area of 45.17 sq ft. (Round results to two decimal places.)

- A) $r = 14.36$ ft, $C = 90.23$ ft B) $r = 3.79$ ft, $C = 8.86$ ft
 C) $r = 3.79$ ft, $C = 23.81$ sq ft D) $r = 3.79$ ft, $C = 23.81$ ft

Answer: D

- 532) The volume of water added to a circular drum of radius r is given by $V_w = 30t$, where V_w is volume in cu ft and t is time in sec. Find the depth of water in a drum of radius 5 ft after adding water for 17 sec. (Round result to one decimal place.)

- A) 20.4 ft B) 2.5 ft C) 6.5 ft D) 13.0 ft

Answer: C

533) A furniture store buys 105 footstools from a distributor at a cost of \$225 each plus an overhead charge of \$40 per order. The retail markup is 30% on the total price paid. Find the profit on the sale of one footstool.

A) \$67.61

B) \$67.39

C) \$6761.00

D) \$67.50

Answer: A

CHAPTER TEST FORMS

CHAPTER R, FORM A
COLLEGE ALGEBRA AND TRIGONOMETRY

NAME _____
 DATE _____

1. Let $A = \left\{ -9.6, \frac{54}{7}, 6\pi, 0, \sqrt{13}, 2.1\overline{5}, \frac{16}{5}, \sqrt{49} \right\}$.

List the elements of A that belong to the given set.

a. Natural numbers

1. a. _____

b. Rational numbers

b. _____

c. Irrational numbers

c. _____

2. Evaluate the expression if $x = -2$, $y = -4$, and $z = 1$:

2. _____

$$\frac{|2y| - |x|^2}{(y - 3z)^2}$$

3. Identify the property illustrated. Let a , b , and c represent any real numbers.

a. $(a + b)c = ac + bc$

3. a. _____

b. $a + [b + (-b)] = a + 0$

b. _____

c. $\left(\frac{1}{2} \cdot \frac{2}{3}\right) \cdot \frac{3}{4} = \frac{1}{2} \cdot \left(\frac{2}{3} \cdot \frac{3}{4}\right)$

c. _____

d. $\frac{1}{2}(p + 3) = (p + 3) \cdot \frac{1}{2}$

d. _____

Perform the indicated operations.

4. $[(3a + b) - 2]^2$

4. _____

5. $(3x^2 - 2x - 5) - (2x^3 + x - 7) + 2x^2(x - 3)$

5. _____

6. $(x^2 - x + 2)(2x - 3)$

6. _____

7. $[(x - y) - 7][(x - y) + 7]$

7. _____

8. $(2x + 5)^3$

8. _____

9. $\frac{3y^4 - 5y^3 - 14y^2 + 10y}{y^2 - 2}$

9. _____

10. $\frac{x^2 - 9}{x^2 - x} \cdot \frac{x - 1}{x^2 - 3x}$

10. _____

11. $\frac{3x}{x - 4} - \frac{x}{x + 4} - \frac{3x + 1}{16 - x^2}$

11. _____

CHAPTER R, FORM A

12. $\frac{3a + 4b}{7a - 5b} - \frac{4a - 9b}{5b - 7a}$ 12. _____

13. $\frac{xy}{\frac{11}{x} + \frac{11}{y}}$ 13. _____

14. During the years from 1975 to 2011, the rate of new lung cancer cases per 100,000 females in the year t (where $t = 0$ corresponds to 1975) can be approximated by the polynomial $-0.00067t^3 - 0.011t^2 + 1.87t + 23.67$. According to this model, what was the rate of new lung cancer cases per 100,000 females in 2006? (Round to the nearest whole number.) 14. _____

Factor completely.

15. $x^3y^2 - 4x^3 + 8y^2 - 32$ 15. _____

16. $8a^3 + 64b^3$ 16. _____

17. $6x^4 - 11x^3 - 35x^2$ 17. _____

18. $28x^2 + 4x - 9$ 18. _____

19. Evaluate $\left(\frac{125}{27}\right)^{-2/3}$. 19. _____

20. Simplify $\left(\frac{x^{2/3}y^{3/4}z^{-1/2}}{x^{-1/4}z^{-1/6}}\right)^{-6}$ so that there are no negative exponents. Assume that all variables represent positive real numbers. 20. _____

Simplify. Assume that all variables represent positive real numbers.

21. $\sqrt[3]{8x^5y^3z^4}$ 21. _____

22. $x\sqrt{112x} + 4\sqrt{175x^3}$ 22. _____

23. $(3 + 4\sqrt[3]{2})(5 - \sqrt[3]{4})$ 23. _____

24. Rationalize the denominator of $\frac{12}{5 - 2\sqrt{7}}$ and simplify. 24. _____

CHAPTER R, FORM A

25. The wind chill factor w is given by the equation
 $w = 35.74 + 0.6215T - 35.75V^{0.16} + 0.4275TV^{0.16}$
where T represents the temperature in degrees Fahrenheit
and V represents the wind velocity. Find the wind chill factor
when the temperature is -40°F and the wind velocity is
15 mph. (Round to the nearest tenth.)

25. _____

CHAPTER R, FORM B
COLLEGE ALGEBRA AND TRIGONOMETRY

NAME _____
 DATE _____

1. Let $A = \left\{ 17, \frac{2}{5}, 0, -\pi, -\frac{12}{3}, \sqrt{3}, -4\bar{2}, \sqrt{25} \right\}$

List the elements of A that belong to the given set.

a. Natural numbers

b. Integers

c. Irrational numbers

1. a. _____

b. _____

c. _____

2. Evaluate the expression if $x = 1$, $y = -2$, and $z = 3$:

$$\frac{-4|2x + 3y|}{2y^2 - z}$$

2. _____

3. Identify the property illustrated. Let a , b , and c represent any real numbers.

a. $\frac{1}{2} + \left(-\frac{1}{2} + b\right) = \left[\frac{1}{2} + \left(-\frac{1}{2}\right)\right] + b$

b. $(a + b)c = c(a + b)$

c. $2a + 0 = 2a$

d. $\frac{3}{4} \cdot \frac{4}{3} = 1$

3. a. _____

b. _____

c. _____

d. _____

Perform the indicated operations.

4. $[(3x - y) - 1]^2$

4. _____

5. $(x^2 + 2y)(x^2 - 2y)$

5. _____

6. $x(x^2 - 1) - x^2(x + 2) - x(2x - 2)$

6. _____

7. $[(x - 3) + y][(x - 3) - y]$

7. _____

8. $(2x - 3y)^3$

8. _____

9. $\frac{6x^4 - 7x^3 + 5x^2 - 11x}{3x - 2}$

9. _____

10. $\frac{3x^2 + 7x + 2}{x^2 + 2x} \cdot \frac{x^2 - x}{3x^2 + x}$

10. _____

11. $\frac{2x}{x^2 - 25} - \frac{x + 1}{x^2 + 5x}$

11. _____

CHAPTER R, FORM B

12. $\frac{9x}{3x-7} + \frac{21}{7-3x}$ 12. _____

13. $\frac{\frac{x}{x+2} - \frac{2}{x-1}}{\frac{3}{x+2} + \frac{x}{x-1}}$ 13. _____

14. During the years from 1975 to 2011, the rate of new lung cancer cases per 100,000 males in the year t (where $t = 0$ corresponds to 1975) can be approximated by the polynomial $0.0029t^3 - 0.21t^2 + 3.12t + 84.17$. According to this model, what was the rate of new lung cancer cases per 100,000 males in 2000? (Round to the nearest whole number.) 14. _____

Factor completely.

15. $8x^2 - 53x - 21$ 15. _____

16. $3x^3 + 3x^2 - 27x - 27$ 16. _____

17. $x^3y^3 - 16x^3y - y^3 + 16y$ 17. _____

18. $12ab^3 - 3abc^2$ 18. _____

19. Evaluate $\left(-\frac{27}{64}\right)^{-2/3}$. 19. _____

20. Simplify $\left(\frac{a^{2/3}b^{-3/4}c^{-1/5}}{a^{1/2}b^{1/4}}\right)^{10}$ so that there are no negative exponents. Assume that all variables represent positive real numbers. 20. _____

Simplify. Assume that all variables represent positive real numbers.

21. $\sqrt{75x^{16}y^7z^{10}}$ 21. _____

22. $2\sqrt{24x} - 5\sqrt{54x} + 8\sqrt{6x}$ 22. _____

23. $(3 + 4\sqrt[3]{25})(2 - 3\sqrt[3]{5})$ 23. _____

24. Rationalize the denominator of $\sqrt[3]{\frac{1}{2}} + \sqrt[3]{\frac{1}{16}}$ and simplify. 24. _____

CHAPTER R, FORM B

25. Police sometimes use the following procedure to estimate the speed at which a car was traveling at the time of an accident: A police officer drives a car that is the same type as the one involved in the accident under conditions similar to those during which the accident took place and then skids to a stop. If the car is driven at 30 mph, then the speed at the time of the accident is given by

$$s = 30\sqrt{\frac{a}{p}},$$

where a is the length of the skid marks left at the time of the accident and p is the length of the skid marks in the police test. Find s , the speed, when a is 325 ft and p is 102 ft. (Round to the nearest tenth.)

25. _____

CHAPTER R, FORM C
COLLEGE ALGEBRA AND TRIGONOMETRY

NAME _____
 DATE _____

1. Let $A = \left\{ \frac{70}{10}, -\frac{1}{8}, -2\pi, 0, \sqrt{64}, \sqrt{19}, 1.\overline{23}, -4, 2.76 \right\}$.

List the elements of A that belong to the given set.

- a. Rational numbers
- b. Real numbers
- c. Whole numbers

- 1. a. _____
- b. _____
- c. _____

2. Evaluate the expression if $x = -2$, $y = -1$, and $z = 3$:

$$\frac{-x^2 + 3|y|}{x(y + 2z)}$$

2. _____

3. Identify the property illustrated. Let a , b , and c represent any real numbers.

a. $\frac{1}{3}(a + b) = \frac{1}{3}(b + a)$

3. a. _____

b. $\frac{1}{2} + \left(-\frac{1}{2}\right) = 0$

b. _____

c. $9(a + b) = 9a + 9b$

c. _____

d. $2(9a) = (2 \cdot 9)a$

d. _____

Perform the indicated operations.

4. $[(x - 4y) + 2]^2$

4. _____

5. $-3(x^3 - x) + 2(x^2 + x) + 3(x^3 - 2x)$

5. _____

6. $(3x + 2y)(2x^2 - 3xy + 4y^2)$

6. _____

7. $[(a + 5) - 2b][(a + 5) + 2b]$

7. _____

8. $(4b - 3c)^3$

8. _____

9. $\frac{x^5 - 2x^3 - 3x^2 + 9}{x^3 - 2}$

9. _____

10. $\frac{6x^2 - 5x - 6}{x^2 - 4} \div \frac{2x^2 - 3}{x + 2}$

10. _____

11. $\frac{x^2 + x - 20}{x^2 - 16} \cdot \frac{x^2 - 25}{x - 5}$

11. _____

CHAPTER R, FORM C

12. $\frac{3a + 4b}{7a - 5b} + \frac{10a - b}{5b - 7a}$ 12. _____

13. $\frac{\frac{2}{x} - 1}{\frac{4}{x^2} - 1}$ 13. _____

14. During the years from 1975 to 2011, the rate of new lung cancer cases per 100,000 females in the year t (where $t = 0$ corresponds to 1975) can be approximated by the polynomial $-0.00067t^3 - 0.011t^2 + 1.87t + 23.67$. According to this model, what was the rate of new lung cancer cases per 100,000 females in 2008? (Round to the nearest whole number.) 14. _____

Factor completely.

15. $10x^2 - 19xy + 6y^2$ 15. _____

16. $x^4 - 16$ 16. _____

17. $a^3 + 2a^2b - 4ab^2 - 8b^3$ 17. _____

18. $2x^4 - 18x^2y^2$ 18. _____

19. Evaluate $\left(\frac{27}{64}\right)^{-4/3}$. 19. _____

20. Simplify $\left(\frac{a^{-3/8}b^{-1/6}}{a^{5/4}b^{-2/3}c^{-3/4}}\right)^{-12}$ so that there are no negative exponents. Assume that all variables represent positive real numbers. 20. _____

Simplify. Assume that all variables represent positive real numbers.

21. $\sqrt{80a^5b^{13}}$ 21. _____

22. $\sqrt[3]{16xy^4} + y\sqrt[3]{2xy} - \sqrt[3]{54xy^4}$ 22. _____

23. $(3\sqrt{x} + 2\sqrt{y})(3\sqrt{x} - 2\sqrt{y})$ 23. _____

24. Rationalize the denominator of $\frac{12}{\sqrt{3} + \sqrt{7}}$ and simplify. 24. _____

CHAPTER R, FORM C

25. Police sometimes use the following procedure to estimate the speed at which a car was traveling at the time of an accident: A police officer drives a car that is the same type as the one involved in the accident under conditions similar to those during which the accident took place and then skids to a stop. If the car is driven at 30 mph, then the speed at the time of the accident is given by

$$s = 30\sqrt{\frac{a}{p}},$$

where a is the length of the skid marks left at the time of the accident and p is the length of the skid marks in the police test. Find s , the speed, when a is 375 ft and p is 185 ft. (Round to the nearest tenth).

25. _____

CHAPTER R, FORM D
COLLEGE ALGEBRA AND TRIGONOMETRY

NAME _____
 DATE _____

1. Let $A = \left\{ \sqrt{5}, -17.8, -3\bar{6}, 0, -\frac{10}{2}, \sqrt{49}, 3\pi, \frac{5}{3}, 8 \right\}$.

List the elements of A that belong to the given set.

- a. Natural numbers
- b. Rational numbers
- c. Integers

- 1. a. _____
- b. _____
- c. _____

2. Evaluate the expression if $x = -3$, $y = -4$, and $z = 1$:

$$\frac{|2x + 5z|}{(2|x| - y)^2}$$

2. _____

3. Identify the property illustrated. Let a , b and c represent any real numbers.

a. $a(b + c) = (b + c)a$

b. $\left(\frac{2}{7} \cdot \frac{1}{5}\right)b = \frac{2}{7} \cdot \left(\frac{1}{5}b\right)$

c. $\frac{1}{4} \cdot 1 = \frac{1}{4}$

d. $4[a + (-a)] = 4a + 4(-a)$

- 3. a. _____
- b. _____
- c. _____
- d. _____

Perform the indicated operations.

4. $[(2x - 3y) - 2]^2$

5. $(2x^2 - 3x + 1)(x^2 + x - 2)$

6. $(3x^3 - 4x^2 + x - 7) + (x^4 - 2x^3 + 3x^2 + 5)$

7. $[(r + 2s) - 4][(r + 2s) + 4]$

8. $(2a + b)^3$

9. $\frac{2y^4 - 2y^3 - 11y^2 + 6y}{y^2 - 3}$

10. $\frac{2x^2 + x - 3}{3x^2 - 7x + 4} \div \frac{10x + 15}{3x^2 - x - 4}$

11. $\frac{x - 4}{x^2 - 10x + 16} - \frac{x + 1}{x^2 + 5x - 14}$

- 4. _____
- 5. _____
- 6. _____
- 7. _____
- 8. _____
- 9. _____
- 10. _____
- 11. _____

CHAPTER R, FORM D

12. $\frac{x+3}{x^2-4} + \frac{2x+5}{4-x^2}$ 12. _____

13. $\frac{\frac{1}{x+2}-3}{\frac{4}{x}-x}$ 13. _____

14. During the years from 1975 to 2011, the rate of new lung cancer cases per 100,000 males in the year t (where $t = 0$ corresponds to 1975) can be approximated by the polynomial $0.0029t^3 - 0.21t^2 + 3.12t + 84.17$. According to this model, what was the rate of new lung cancer cases per 100,000 males in 2010? (Round to the nearest whole number.) 14. _____

Factor completely.

15. $18x^2 - 27x + 4$ 15. _____

16. $6x^4 + 11x^2 - 10$ 16. _____

17. $r^4 - 8rs^3 - 2r^3s + 16s^4$ 17. _____

18. $8x^3 + 64y^3$ 18. _____

19. Evaluate $\left(\frac{16}{49}\right)^{-3/2}$. 19. _____

20. Simplify $\left(\frac{x^{3/2}y^{-4/3}z^{5/6}}{x^{2/3}y^{5/4}z^{-1/4}}\right)^6$ so that there are no negative exponents. Assume that all variables represent positive real numbers. 20. _____

Simplify. Assume that all variables represent positive real numbers.

21. $\sqrt{84a^{14}b^{18}c^5}$ 21. _____

22. $\sqrt[4]{768x^5} + \sqrt[4]{48x^5}$ 22. _____

23. $(\sqrt{10} + 2\sqrt{6})(\sqrt{10} - \sqrt{6})$ 23. _____

24. Rationalize the denominator of $\sqrt{\frac{1}{3}} - \sqrt{\frac{1}{27}}$ and simplify. 24. _____

CHAPTER R, FORM D

25. The length of one leg of a right triangle is

$$a = \sqrt{c^2 - b^2}$$

where c is the length of the hypotenuse and b is the length of the other leg. Find the length of the unknown leg if the length of the hypotenuse is 45 m and the length of the other leg is 28 m. (Round to the nearest tenth.)

25. _____

CHAPTER R, FORM E
COLLEGE ALGEBRA AND TRIGONOMETRY

NAME _____
 DATE _____

1. Let $A = \left\{ \frac{5}{8}, -3.\bar{2}, \frac{\pi}{8}, -4, \sqrt{64}, \sqrt{3}, \frac{12}{2}, 0 \right\}$.

List the elements of A that belong to the given set.

A. Rational numbers

a. $\left\{ \frac{5}{8}, -3.\bar{2}, -4, \sqrt{64}, \frac{12}{2} \right\}$

b. $\left\{ -4, \sqrt{64}, \frac{12}{2}, 0 \right\}$

c. $\left\{ \frac{5}{8}, -4, \sqrt{64}, \frac{12}{2}, 0 \right\}$

d. $\left\{ \frac{5}{8}, -3.\bar{2}, -4, \sqrt{64}, \frac{12}{2}, 0 \right\}$

B. Real numbers

a. $\left\{ \frac{\pi}{8}, \sqrt{3} \right\}$

b. $\left\{ -4, \sqrt{64}, \frac{12}{2}, 0 \right\}$

c. $\left\{ \frac{5}{8}, -3.\bar{2}, \frac{\pi}{8}, -4, \sqrt{64}, \sqrt{3}, \frac{12}{2}, 0 \right\}$

d. $\left\{ -3.\bar{2}, \frac{\pi}{8}, \sqrt{3} \right\}$

C. Natural numbers

a. $\left\{ \frac{5}{8}, -3.\bar{2}, -4, \sqrt{64}, \frac{12}{2}, 0 \right\}$

b. $\left\{ -4, \sqrt{64}, \frac{12}{2}, 0 \right\}$

c. $\left\{ \sqrt{64}, \frac{12}{2}, 0 \right\}$

d. $\left\{ \sqrt{64}, \frac{12}{2} \right\}$

2. Evaluate the expression if $x = -5$ and $y = -2$:

$$\frac{|x-4|-|2y|}{|-3y-4x|}$$

a. $\frac{5}{23}$

b. $\frac{5}{26}$

c. $\frac{5}{14}$

d. $\frac{1}{2}$

1. **A.** _____

B. _____

C. _____

2. _____

CHAPTER R, FORM E

3. Identify the property illustrated. Let a and b represent any real numbers.

A. $\left(\frac{1}{3} + 0\right) \cdot \frac{2}{7} = \frac{1}{3} \cdot \frac{2}{7}$

- a. Associative
- b. Inverse
- c. Identity
- d. Commutative

3. A. _____

B. $8(a + b) = 8(b + a)$

- a. Associative
- b. Distributive
- c. Identity
- d. Commutative

B. _____

C. $4(2 + 3) = 4 \cdot 2 + 4 \cdot 3$

- a. Associative
- b. Distributive
- c. Commutative
- d. Inverse

C. _____

D. $a + (-a) = 0$

- a. Inverse
- b. Identity
- c. Associative
- d. Distributive

D. _____

Perform the indicated operations.

4. $[(2a - b) + 7]^2$

- a. $4a^2 + b^2 + 49$
- b. $4a^2 - 4ab + b^2 + 28a - 14b + 49$
- c. $4a^2 - b^2 + 49$
- d. $4a^2 - 4ab + b^2 + 14a - 7b + 49$

4. _____

5. $(8x^2 + 3x - 4) + (7x^2 + 9x + 8)$

- a. $15x^2 + 12x - 4$
- b. $15x^2 - 12x + 4$
- c. $15x^2 + 12x + 4$
- d. $3x^2 + 17x + 11$

5. _____

6. $(3s - 1)(s^2 - 4s + 2)$

- a. $3s^3 - 13s^2 - 10s - 2$
- b. $3s^3 - 13s^2 + 2s - 2$
- c. $3s^3 - 13s^2 + 10s - 2$
- d. $3s^3 - 13s^2 - 2s - 2$

6. _____

7. $[(2s + t) - 3][(2s + t) + 3]$

- a. $4s^2 + t^2 - 9$
- b. $4s^2 + 4st + t^2 - 9$
- c. $4s^2 + 4st + t^2 + 9$
- d. $4s^2 + t^2 + 9$

7. _____

8. $(4x - 3)^3$

- a. $64x^3 - 96x^2 + 72x - 27$
- b. $64x^3 - 27$
- c. $64x^3 - 144x^2 + 108x - 27$
- d. $64x^3 - 192x^2 + 144x - 27$

8. _____

CHAPTER R, FORM E

9. $\frac{-2x^3 + 7x^2 - 7x + 12}{2x - 1}$

9. _____

a. $-x^2 + 3x - 2 + \frac{14}{2x - 1}$

b. $-x^2 + 4x - 11 + \frac{23}{2x - 1}$

c. $-x^2 + 4x - 11 + \frac{1}{2x - 1}$

d. $-x^2 + 3x - 2 + \frac{10}{2x - 1}$

10. The amount spent on health care on in the United States can be determined by the polynomial $y = 1.45x^2 + 5.36x + 261.9$, where $x = 0$ corresponds to 1975 and y is in billions of dollars. Based on this model, approximately how much was spent on health care in 2000?

10. _____

- a. 1.302 trillion
c. 13.02 billion

- b. 1.302 billion
d. 13.02 trillion

Factor completely.

11. $x^2 + 6x - 72$

11. _____

a. $(x - 12)(x + 6)$

b. $(x + 12)(x - 6)$

c. $(x - 12)(x + 1)$

d. $(x + 12)(x + 6)$

12. $8x^3 - 125$

12. _____

a. $(2x + 5)(4x^2 - 10x + 25)$

b. $(2x - 5)(4x^2 + 20x + 25)$

c. $(2x - 5)(4x^2 + 10x + 25)$

d. $(2x + 5)(4x^2 - 20x + 25)$

13. $75y^4 - 147y^2$

13. _____

a. $3(5y^2 + 7)(5y^2 - 7)$

b. $3y^2(5y + 7)(5y - 7)$

c. $3y^2(5y - 7)^2$

d. $3y(5y - 7)^2$

14. $4x^2 - y^2 - 6y - 9$

14. _____

a. $(4x - y + 3)(4x + y - 3)$

b. $(2x - y + 3)(2x + y - 3)$

c. $(2x - y - 3)(2x + y + 3)$

d. $(4x - y - 3)(4x + y + 3)$

Perform the indicated operations.

15. $\frac{x^2 + 3x + 2}{x^2 + x - 2} \cdot \frac{x^2 - 4}{x^2 - x - 2}$

15. _____

a. $\frac{x + 1}{x - 2}$

b. $\frac{x - 2}{x - 1}$

c. $\frac{x - 2}{x + 1}$

d. $\frac{x + 2}{x - 1}$

CHAPTER R, FORM E

16. $\frac{2y-2}{y^2-4y} - \frac{y+8}{y^2-16}$

16. _____

a. $\frac{3y^2+14y-8}{y(y-4)(y+4)}$

b. $\frac{y^2+14y-8}{y(y-4)(y+4)}$

c. $\frac{y+2}{y(y+4)}$

d. $\frac{y-10}{2(y-4)(y+2)}$

17. $\frac{\frac{4}{x^2} - \frac{1}{4}}{\frac{2}{x} - \frac{1}{2}}$

17. _____

a. $\frac{3}{2x}$

b. $\frac{3}{x-2}$

c. $\frac{4+x}{2x}$

d. $\frac{4x}{x-2}$

18. $\frac{3x+12}{10} \div \frac{5x+20}{20}$

18. _____

a. $\frac{3x+12}{50x}$

b. $\frac{8x+32}{30}$

c. $\frac{3}{40}$

d. $\frac{6}{5}$

19. Evaluate $\left(\frac{49}{25}\right)^{-3/2}$.

19. _____

a. $-\frac{125}{343}$

b. $\frac{343}{125}$

c. $\frac{125}{343}$

d. $-\frac{343}{125}$

20. Simplify $\left(\frac{x^{2/5}y^{1/4}z^{-3/4}}{x^{-3/4}y^{1/5}}\right)^{10}$ so that there are no negative exponents.

20. _____

Assume that all variables represent positive real numbers.

a. $\frac{x^{23/2}y^{1/2}}{z^{15/2}}$

b. $x^{23/20}y^{1/20}z^{37/4}$

c. $\frac{y^{9/2}}{x^{7/2}z^{15/2}}$

d. $x^{393/20}y^{409/20}z^{37/4}$

Simplify. Assume that all variables represent positive real numbers.

21. $\sqrt[3]{125x^5y^6}$

21. _____

a. $5x^2y^2\sqrt[3]{xy}$

b. $5xy\sqrt[3]{xy}$

c. $5xy^2\sqrt[3]{x^2}$

d. $5xy\sqrt[3]{x}$

CHAPTER R, FORM E

22. $\sqrt{3x} - 2\sqrt{12x} + 4\sqrt{18x}$ 22. _____

a. $9x\sqrt{6}$

b. $\sqrt{3x} + 8\sqrt{2x}$

c. $-3\sqrt{3x} + 12\sqrt{2x}$

d. $9\sqrt{3x}$

23. $(\sqrt{10} + 2\sqrt{5})^2$ 23. _____

a. 30

b. $30 + 20\sqrt{2}$

c. $30 + 10\sqrt{2}$

d. 20

24. Rationalize the denominator of $\frac{15}{2\sqrt{7} - \sqrt{10}}$. 24. _____

a. $\frac{5(2\sqrt{7} - \sqrt{10})}{6}$

b. $\frac{15(2\sqrt{7} + \sqrt{10})}{4}$

c. $\frac{5(2\sqrt{7} + \sqrt{10})}{6}$

d. $\frac{15(2\sqrt{7} - \sqrt{10})}{4}$

25. One of the two solutions of a quadratic equation, x , can be found by the formula 25. _____

$$x = \frac{-b + \sqrt{b^2 - 4ac}}{2a},$$

where a is the coefficient of the squared term, b is the coefficient of the linear term, and c is the constant term. Find one of the solutions if $a = 5$, $b = -7$, and $c = -6$.

a. 2

b. $-\frac{4}{5}$

c. $\frac{7 - \sqrt{71}}{10}$

d. $\frac{7 + \sqrt{71}}{10}$

CHAPTER R, FORM F
COLLEGE ALGEBRA AND TRIGONOMETRY

NAME _____
 DATE _____

1. Let $B = \left\{ \sqrt{10}, -1.55, 12, \frac{15}{5}, -\pi, \sqrt{64}, 0, \frac{5}{14} \right\}$.

List the elements of B that belong to the given set.

A. Irrational numbers

1. **A.** _____

a. $\left\{ \sqrt{10}, -1.55, 12, \frac{15}{5}, -\pi, \sqrt{64}, 0, \frac{5}{14} \right\}$ **b.** $\left\{ \sqrt{10}, -1.55, -\pi, \sqrt{64}, 0 \right\}$

c. $\left\{ \sqrt{10}, -\pi, 0 \right\}$ **d.** $\left\{ \sqrt{10}, -\pi \right\}$

B. Natural numbers

B. _____

a. $\left\{ 12, \frac{15}{5}, \sqrt{64}, 0 \right\}$ **b.** $\left\{ 12, \frac{15}{5}, \sqrt{64} \right\}$

c. $\left\{ 12, \frac{15}{5}, 0, -1.55, \sqrt{64} \right\}$ **d.** $\left\{ 12, \frac{15}{5} \right\}$

C. Integers

C. _____

a. $\left\{ 12, \frac{15}{5}, \sqrt{64} \right\}$ **b.** $\left\{ 12, \frac{15}{5}, \sqrt{64}, 0 \right\}$

c. $\left\{ 12, \frac{15}{5} \right\}$ **d.** $\left\{ 12, \frac{15}{5}, 0, -1.55, \sqrt{64}, \frac{5}{14} \right\}$

2. Evaluate the expression if $x = -2$, $y = 1$, and $z = -3$:

2. _____

$$\frac{|5x - 2y|}{|x| + 2z^2}$$

a. $-\frac{1}{3}$ **b.** $\frac{3}{5}$ **c.** $-\frac{1}{4}$ **d.** $\frac{1}{3}$

3. Identify the property illustrated. Let a and b represent any real numbers.

3. **A.** _____

A. $1 \cdot \sqrt{3} = \sqrt{3}$

- a.** Associative **b.** Inverse
c. Identity **d.** Distributive

B. $(x + y) + 0 = x + (y + 0)$

B. _____

- a.** Associative **b.** Commutative
c. Identity **d.** Distributive

CHAPTER R, FORM F

C. $\frac{\pi}{3} \cdot \frac{3}{\pi} = 1$

C. _____

- a. Commutative
- c. Identity

- b. Inverse
- d. Distributive

D. $9(a+b) = 9(b+a)$

D. _____

- a. Associative
- c. Commutative

- b. Distributive
- d. Inverse

Perform the indicated operations.

4. $[(3a+2b)-2]^2$

4. _____

- a. $9a^2 + 4b^2 - 4$
- c. $9a^2 + 12ab + 4b^2 - 6a - 4b + 4$

- b. $9a^2 + 12ab + 4b^2 - 12a - 8b + 4$
- d. $9a^2 + 4b^2 + 4$

5. $(-2x-5y)(-2x+8y)$

5. _____

- a. $4x^2 - 6xy - 6y^2$
- c. $4x^2 - 6xy - 40y^2$

- b. $4x^2 + 10xy - 40y^2$
- d. $4x^2 - 16xy - 40y^2$

6. $(-2x^2 + 5x + 8) - (x^3 - 7x - 2) + 4x(x^2 - 3)$

6. _____

- a. $3x^3 - 2x^2 - 14x + 6$
- c. $5x^3 - 2x^2 - 14x + 6$

- b. $-5x^3 - 2x^2 - 14x + 6$
- d. $3x^3 - 2x^2 + 10$

7. $[(r-2)+3s][(r-2)-3s]$

7. _____

- a. $r^2 + 4 - 9s^2$
- c. $r^2 - 4r - 4 - 9s^2$

- b. $r^2 - 4 - 9s^2$
- d. $r^2 - 4r + 4 - 9s^2$

8. $(x+3)^4$

8. _____

- a. $x^4 + 6x^3 + 18x^2 + 54x + 81$
- c. $x^4 + 81$

- b. $x^4 + 6x^3 + 36x^2 + 54x + 81$
- d. $x^4 + 12x^3 + 54x^2 + 108x + 81$

CHAPTER R, FORM F

9. $\frac{3x^3 + 5x - 8}{x - 2}$

a. $3x^2 + 11x + 22 + \frac{36}{x - 2}$

c. $3x^2 - 6x + 17 - \frac{42}{x - 2}$

b. $3x^2 + 11x + \frac{14}{x - 2}$

d. $3x^2 + 6x + 17 + \frac{26}{x - 2}$

10. The amount spent on health care on in the United States can be determined by the polynomial $y = 1.45x^2 + 5.36x + 261.9$, where $x = 0$ corresponds to 1975 and y is in billions of dollars. Based on this model, approximately how much was spent on health care in 2002?

- a. 14.63 billion
c. 1.463 trillion

- b. 1.463 billion
d. 14.63 trillion

9. _____

10. _____

Factor completely.

11. $18x^2 - 78x - 60$

a. $(18x + 12)(x - 5)$

c. $6(3x - 2)(x + 5)$

b. $6(3x + 2)(x - 5)$

d. $6(3x + 2)(x + 5)$

12. $125x^3 + 216y^3$

a. $(5x - 6y)(25x^2 + 30xy + 36y^2)$

c. $(5x + 6y)(25x^2 - 60xy + 36y^2)$

b. $(5x + 6y)(25x^2 - 30xy + 36y^2)$

d. $(5x - 6y)(25x^2 + 60xy + 36y^2)$

13. $100a^2 - 16$

a. $(10a - 4)(10a + 4)$

c. $4(5a - 2)(5a + 2)$

b. $2(5a - 2)^2$

d. $4(5a - 2)^2$

14. $r^3s^2 + 4r^3 - 8s^2 - 32$

a. $(r - 2)(r + 2)^2(s - 2)(s + 2)$

c. $(r - 2)(r^2 + 2r + 4)(s - 2)(s + 2)$

b. $(r - 2)(r^2 + 2r + 4)(s^2 + 4)$

d. $(r - 2)(r^2 - 2r + 4)(s - 2)(s + 2)$

11. _____

12. _____

13. _____

14. _____

Perform the indicated operations.

15. $\frac{x^2 + 5x - 14}{x^2 - 4} \div \frac{x^2 + 12x + 35}{x^2 + 12x + 20}$

a. $\frac{x + 10}{x + 5}$

c. $\frac{x + 1}{x + 2}$

b. $\frac{x + 5}{x + 10}$

d. $\frac{x + 2}{x + 1}$

15. _____

CHAPTER R, FORM F

16. $\frac{3a+7}{a^2+5a+6} - \frac{a-5}{a^2+2a-3}$

16. _____

a. $\frac{2a^2-3a-17}{(a+2)(a+3)(a-1)}$

b. $\frac{2a+1}{(a-1)(a+2)}$

c. $\frac{2(a+6)}{3(a+3)}$

d. $\frac{4a^2+a-17}{(a+2)(a+3)(a-1)}$

17. $\frac{\frac{1}{x+3} - \frac{2}{3}}{\frac{2}{x+3} - \frac{1}{3}}$

17. _____

a. $\frac{3+2x}{x-3}$

b. -1

c. $\frac{-3-2x}{1+x}$

d. $\frac{6}{x+3}$

18. $\frac{8s+t}{5s-t} - \frac{2t+7s}{t-5s}$

18. _____

a. $\frac{s-t}{5s-t}$

b. $\frac{t-s}{5s-t}$

c. $\frac{15s+3t}{5s-t}$

d. 3

19. Evaluate $\left(\frac{64}{27}\right)^{-2/3}$

19. _____

a. $\frac{9}{16}$

b. $-\frac{16}{9}$

c. $\frac{16}{9}$

d. $-\frac{9}{16}$

20. Simplify $\left(\frac{x^{5/3}y^{-3/2}}{x^{1/6}y^{5/3}z^{-5/6}}\right)^{18}$ so that there are no negative exponents.

20. _____

Assume that all variables represent positive real numbers.

a. $\frac{x^{27}y^{57}}{z^{15}}$

b. $\frac{x^{27}z^{15}}{y^{57}}$

c. $\frac{x^{33}y^3}{z^{15}}$

d. $\frac{z^{15}}{x^{33}y^3}$

Simplify. Assume that all variables represent positive real numbers.

21. _____

21. $\sqrt{625x^8y^7}$

a. $25x^3y^4\sqrt{xy}$

b. $25x^4\sqrt{y^7}$

c. $25x^8y^7\sqrt{xy}$

d. $25x^4y^3\sqrt{y}$

22. $\sqrt[3]{81x^4y^2} + 4x\sqrt[3]{3xy^2}$

22. _____

a. $7x\sqrt[3]{3xy^2}$

b. $12x^2\sqrt[3]{3xy^2}$

c. $7xy\sqrt[3]{3x}$

d. $12x^2y\sqrt[3]{9x^2y}$

CHAPTER R, FORM F

23. $(2\sqrt{15} + 5\sqrt{3})(-3 + \sqrt{5})$ 23. _____

a. $-\sqrt{15} - 5\sqrt{3}$

b. $-11\sqrt{15} - 5\sqrt{3}$

c. $-11\sqrt{15} - 3\sqrt{5}$

d. $-\sqrt{15} - 3\sqrt{5}$

24. Rationalize the denominator of $\frac{9}{\sqrt{17} + 3\sqrt{2}}$. 24. _____

a. $9(\sqrt{17} + 3\sqrt{2})$

b. $-9(\sqrt{17} - 3\sqrt{2})$

c. $-9(\sqrt{17} + 3\sqrt{2})$

d. $9(\sqrt{17} - 3\sqrt{2})$

25. One of the two solutions of a quadratic equation, x , can be found by the formula 25. _____

$$x = \frac{-b + \sqrt{b^2 - 4ac}}{2a},$$

where a is the coefficient of the squared term, b is the coefficient of the linear term, and c is the constant term. Find one of the solutions if $a = 6$, $b = 13$, and $c = -8$.

a. 4

b. $\frac{1}{2}$

c. $\frac{-13 + \sqrt{23}}{12}$

d. $\frac{-13 - \sqrt{23}}{12}$

CHAPTER 1, FORM A
COLLEGE ALGEBRA AND TRIGONOMETRY

NAME _____
DATE _____

Solve each equation.

1. $5 + 4(x - 1) = 2x + 2(x + 4)$ 1. _____

2. $\frac{2x - 9}{4} = 2 + \frac{x}{12}$ 2. _____

3. $48x^2 + 12x = 90$ 3. _____

4. $3x^2 = 2(x - 1)$ 4. _____

5. $\frac{3x}{x - 2} + \frac{1}{x + 2} = \frac{-4}{x^2 - 4}$ 5. _____

6. $\sqrt{x + 3} + \sqrt{2 - x} = 3$ 6. _____

7. $\sqrt{x - 1} + x = 3$ 7. _____

8. $x^4 - 13x^2 + 36 = 0$ 8. _____

9. $(x - 5)^{2/3} + 3(x - 5)^{1/3} - 4 = 0$ 9. _____

10. $|x - 1| + 8 = 8$ 10. _____

11. $|x - 3| = |2x + 3|$ 11. _____

12. The formula for the surface area of an open topped rectangular box is $S = LW + 2LH + 2WH$ where S, H, W and L represent surface area, height, width, and length, respectively. Solve this formula for W . 12. _____

Perform each operation. Give the answer in standard form.

13. $(1 - 3i)(2 + 5i)$ 13. _____

14. $(8 + 2i) + (1 - 6i) - (3i - 2)$ 14. _____

15. $\frac{2 + i}{7 - 5i}$ 15. _____

CHAPTER 1, FORM A

16. Simplify the following power of i : i^{73}

16. _____

Solve each inequality. Give the answer using interval notation.

17. $x^2 + 4 > 5x$

17. _____

18. $0 \leq 4 - \frac{1}{3}x < 2$

18. _____

19. $\frac{x}{7} - 3 > \frac{x-4}{3} + 1$

19. _____

20. $|2x - 1| \geq 3$

20. _____

21. $|4 - 2x| > 6$

21. _____

Solve each problem.

22. Bob Grey invests \$22,000, some at 2% and some at 4% annual interest. If he receives an annual return of \$670, how much is invested at each rate?

22. _____

23. Jack can paint his apartment in 12 hr. His wife Cheryl requires 20 hr to do the same job. How long would it take them to complete the job if they worked together?

23. _____

24. A baseball is thrown straight upward with an initial speed of 64 ft/sec. The number of feet s above the ground after t seconds is given by the equation $x = -16t^2 + 64t$. At what times will the baseball be 48 ft above the ground?

24. _____

25. The number y of students attending Nequa Valley High School between 1988 and 1996 can be approximated by the model $y = 45.28x^2 - 37.6x + 585$, where $x = 0$ corresponds to 1988. Based on this model, in what year did the school have about 1550 students?

25. _____

CHAPTER 1, FORM B
COLLEGE ALGEBRA AND TRIGONOMETRY

NAME _____
DATE _____

Solve each equation.

1. $\frac{3}{5}x - 2 = 2 + \frac{3}{2}x$

1. _____

2. $2x(x + 3) = -1$

2. _____

3. $\frac{2}{7}(x - 4) - x = -4 - \frac{3}{5}x$

3. _____

4. $(x - 3)^2 = -4$

4. _____

5. $\frac{2}{x+5} - \frac{3}{2x+1} = \frac{5}{6x+3}$

5. _____

6. $x^4 - 3x^2 = 4$

6. _____

7. $\sqrt[3]{x-1} = \sqrt[3]{x^2+2x-21}$

7. _____

8. $\sqrt{x+4} + \sqrt{2x} = 2$

8. _____

9. $|x - 2| = |3x + 8|$

9. _____

10. $|3x - 4| = x$

10. _____

11. $(x - 2)^{2/3} + 2(x - 2)^{1/3} - 8 = 0$

11. _____

12. $\left(\frac{x}{x-2}\right)^2 - \frac{2x}{x-2} - 15 = 0$

12. _____

Perform each operation. Give the answer in standard form.

13. $-(7 - 3i) + (4 + i) - (-1 + i)$

13. _____

14. $(4 + 2i)(-5 + 4i)$

14. _____

CHAPTER 1, FORM B

15. $\frac{4-5i}{2+3i}$

15. _____

16. Simplify the following power of i : i^{94}

16. _____

Solve each inequality. Give the answer using interval notation.

17. $6x^2 - 5x \leq -1$

17. _____

18. $7 + \frac{x}{2} < \frac{x}{3} - x$

18. _____

19. $\frac{-3}{2-x} < 0$

19. _____

20. $|2x+5| < 4$

20. _____

21. $|2x-1| < 3$

21. _____

Solve each problem.

22. What weight of an alloy containing 10% silver must be melted with an alloy containing 60% silver to obtain 10 lb of an alloy containing 40% silver?

22. _____

23. The cost of installing insulation in a particular two bedroom home is \$2400. Present monthly heating costs average \$200, but the insulation is expected to reduce heating costs by 10%. How many months will it take to recover the cost of the insulation?

23. _____

24. The population y of Stevensville between 1986 and 1995 can be approximated by the model $y = 326.5x^2 - 780.3x + 5670$, where $x = 0$ corresponds to 1986. Based on this model, in what year was the population about 6250?

24. _____

25. A ball is thrown upward from ground level with an initial velocity of 108 ft per sec. Its height h in feet after t seconds is given by the equation $h = -16t^2 + 108t$. At what times will the ball be 180 ft above the ground?

25. _____

CHAPTER 1, FORM C
COLLEGE ALGEBRA AND TRIGONOMETRY

NAME _____
DATE _____

Solve each equation.

1. $4x - 3 = -5x + 6$

1. _____

2. $\frac{2}{5} + \frac{4}{10x+5} = \frac{7}{2x+1}$

2. _____

3. $(4x - 1)^2 + 9 = 0$

3. _____

4. $(x + 2)^2 - 48 = 1$

4. _____

5. $\frac{4x+1}{4} - \frac{x-4}{6} = \frac{2x}{5} - 2$

5. _____

6. $\sqrt{2x+3} - 2 = x$

6. _____

7. $\sqrt[3]{x^2-1} = 2$

7. _____

8. $6x^4 - 7x^2 = -2$

8. _____

9. $3(2z-1)^2 - 11(2z-1) + 10 = 0$

9. _____

10. $|x + 4| = 3x - 8$

10. _____

11. $|7x + 3| = 11$

11. _____

12. Solve the following equation for x : $ax + 2by = 2az - 5bx$

12. _____

Perform each operation. Give the answer in standard form.

13. $(-4 + 2i) - (16 + 8i) + (13 - 2i)$

13. _____

14. $(3 + 5i)(2 - 7i)$

14. _____

15. $\frac{4 - 2i}{-5i}$

15. _____

16. Simplify the following power of i : i^{68}

16. _____

CHAPTER 1, FORM C

Solve each inequality. Give the answer using interval notation.

17. $x^2 - 5x + 4 > 0$

17. _____

18. $\frac{3(4-5x)}{2} + 5x > 1$

18. _____

19. $\frac{x}{2x+1} < -4$

19. _____

20. $|7 - 3x| \leq 2$

20. _____

21. $\left| \frac{2x+5}{3} \right| < 1$

21. _____

Solve each problem.

22. How many pounds of extra-lean hamburger that is 7% fat must be mixed with 30 pounds of hamburger that is 15% fat to obtain a mixture that is 10% fat?

22. _____

23. A workman's basic hourly wage is \$24, but he receives one and a half times his hourly rate for any hours worked in excess of 40 hours per week. If his paycheck for the week is \$1392, how many hours of overtime did he work?

23. _____

24. A ball is thrown upward from ground level with an initial velocity of 108 ft per sec. Its height h in feet after t seconds is given by the equation $h = -16t^2 + 108t$. At what time will the ball hit the ground?

24. _____

25. The number y of visitors to Dragon Lake State park between 1984 and 1992 can be approximated by the model $y = 172.35x^2 - 303.4x + 6972$, where $x = 0$ corresponds to 1984. Based on this model, in what year did the park have about 8500 visitors?

25. _____

CHAPTER 1, FORM D
COLLEGE ALGEBRA AND TRIGONOMETRY

NAME _____
DATE _____

Solve each equation.

1. $\frac{5}{6}(x+8) - \frac{2}{3}(x+6) = 2x+10$

1. _____

2. $(x-2)(x-3) = (x+3)(x+4)$

2. _____

3. $(5x-3)^2 = -49$

3. _____

4. $5x\left(x + \frac{1}{5}\right) = 3$

4. _____

5. $\frac{7}{x-2} - \frac{6}{x^2-4} = \frac{3}{2x+4}$

5. _____

6. $\sqrt{7x+2} = 6-x$

6. _____

7. $\sqrt[3]{x^3-7} + 1 = x$

7. _____

8. $x^4 = 256$

8. _____

9. $(x^2-4x)^2 - 36 = 9(x^2-4x)$

9. _____

10. $|7x-5| = -12$

10. _____

11. $|2x-3| = |3x-5|$

11. _____

12. Solve the following equation for C: $P + N = \frac{C+2}{C}$

12. _____

Perform each operation. Give the answer in standard form.

13. $(3+4i)(2+7i)$

13. _____

14. $(5+3i) + (2-4i) - (3-8i)$

14. _____

15. $\frac{2-\sqrt{-16}}{3+\sqrt{-1}}$

15. _____

CHAPTER 1, FORM D

16. Simplify the following power of i : i^{-55}

16. _____

Solve each inequality. Give the answer using interval notation.

17. $x^2 - 5x < -6$

17. _____

18. $3(x - 2) \leq 2(x + 5)$

18. _____

19. $\frac{4}{x + 1} < 1$

19. _____

20. $1 < |x - 2| < 4$

20. _____

21. $|3x - 9| < 10$

21. _____

Solve each problem.

22. How many gallons of a cream that is 22% butterfat must be mixed with milk that is 2% butterfat to get 20 gallons of milk containing 4% butterfat?

22. _____

23. Jay invested \$28,500 in two accounts, one paying 2.5% simple interest, and the other paying 3.5%. She received \$877.50 in interest for 1 yr. How much did she invest each time?

23. _____

24. An arrow is shot upward from a platform 40 ft high with an initial velocity of 224 ft per sec. Its height h in feet after t seconds is given by the equation $h = -16t^2 + 224t + 40$. At what times will the arrow be 424 ft above the ground?

24. _____

25. The number y of students enrolled in Fox Grove Community College between 1983 and 1990 can be approximated by the model $y = 36.28x^2 - 98.61x + 8605$, where $x = 0$ corresponds to 1983. Based on this model, in what year did the college have about 8800 students?

25. _____

CHAPTER 1, FORM E
COLLEGE ALGEBRA AND TRIGONOMETRY

NAME _____
DATE _____

Choose the best answer.

Solve each equation.

1. $2(x-1)+1=3(x-4)+5(1-2x)+6(1+x)$

- a. \emptyset b. $\{0\}$ c. $\{1\}$ d. $\{2\}$

1. _____

2. $-3x-2+6(x+1)=-5x-3$

- a. $\left\{\frac{7}{3}\right\}$ b. $\left\{-\frac{11}{8}\right\}$ c. $\left\{-\frac{7}{8}\right\}$ d. $\left\{\frac{11}{3}\right\}$

2. _____

3. $5x\left(x+\frac{1}{5}\right)=3$

- a. $\left\{\frac{-4\pm\sqrt{10}}{12}\right\}$ b. $\left\{\frac{-4\pm\sqrt{10}}{6}\right\}$
c. $\left\{\frac{-4\pm\sqrt{22}}{6}\right\}$ d. $\left\{\frac{-8\pm\sqrt{10}}{6}\right\}$

3. _____

4. $x^2+4x-5=0$

- a. $\{-\sqrt{5}, \sqrt{5}\}$ b. $\{-5, 1\}$
c. $\{-1, 5\}$ d. $\{-5, 0\}$

4. _____

5. $\frac{9x}{4}-x=\frac{x}{8}-\frac{7}{2}$

- a. $\left\{\frac{28}{11}\right\}$ b. $\left\{\frac{28}{9}\right\}$ c. $\left\{-\frac{28}{11}\right\}$ d. $\left\{-\frac{28}{9}\right\}$

5. _____

6. $\sqrt[3]{x^2-3x}=\sqrt[3]{3x^2-2}$

- a. $\{-2\}$ b. $\{3\}$ c. $\left\{-2, \frac{1}{2}\right\}$ d. \emptyset

6. _____

7. $\sqrt{14x-7}=x+3$

- a. $\{2\}$ b. $\{-4\}$ c. $\{4\}$ d. $\{-3\}$

7. _____

CHAPTER 1, FORM E

8. $x^4 + 3 = 4x^2$

a. $\{\pm\sqrt{3}, \pm i\}$

c. $\{\pm 1, \pm\sqrt{3}\}$

b. $\{\pm 1, \pm i\sqrt{3}\}$

d. $\{\pm 1, \pm 3\}$

8. _____

9. $x^{2/3} - x^{1/3} - 6 = 0$

a. $\{-8, 27\}$

b. $\{8, -27\}$

c. $\{8, 27\}$

d. $\{-8, -27\}$

9. _____

10. $-3|x-3|=18$

a. $\{-3, 9\}$

b. $\{3\}$

c. $\{-9, 3\}$

d. \emptyset

10. _____

11. $|3-x|=|1-2x|$

a. \emptyset

b. $\{-2\}$

c. $\left\{3, \frac{1}{2}\right\}$

d. $\left\{-2, \frac{4}{3}\right\}$

11. _____

12. Solve the following equation for x : $4ax - 2by = 2cx + 5$

a. $x = \frac{2c+5}{4a-2by}$

b. $x = \frac{2by+5}{4a-2c}$

c. $x = \frac{4a-2c}{2by+5}$

d. $x = \frac{2c+5}{4a-2by}$

12. _____

Perform each operation. Give the answer in standard form.

13. $(-4+2i) + (6+8i) - (13-2i)$

a. $-11+8i$

b. $-11+12i$

c. $-15+8i$

d. $-15+12i$

13. _____

14. $(8-5i)(9+8i)$

a. $-40i^2 + 19i - 72$

b. $112+19i$

c. $112-19i$

d. $32-109i$

14. _____

15. $\frac{6-3i}{5+8i}$

a. $\frac{54}{89} - \frac{33}{89}i$

b. $-\frac{18}{13} - \frac{21}{13}i$

c. $\frac{6}{89} - \frac{63}{89}i$

d. $-\frac{2}{13} - \frac{21}{13}i$

15. _____

CHAPTER 1, FORM E

16. Simplify the following power of i : i^{37} 16. _____
 a. i b. -1 c. $-i$ d. 1

Solve each inequality. Give the answer using interval notation.

17. $2(x+2) \leq \frac{3}{4}x - 1$ 17. _____
 a. $(-\bullet, -4]$ b. $(-4, \bullet)$ c. $[-4, \bullet)$ d. $(-\bullet, 4]$

18. $14 \leq 3x + 5 \leq 23$ 18. _____
 a. $[-6, -3]$ b. $(-6, -3)$
 c. $(3, 6)$ d. $[3, 6]$

19. $\left| \frac{2x-1}{3} < \frac{5}{3} \right|$ 19. _____
 a. $(-2, 3)$ b. $(-3, -2)$ c. $(-3, 2)$ d. $[-2, 3]$

20. $\frac{x}{x-2} \geq 5$ 20. _____
 a. $\left[2, \frac{5}{2} \right)$ b. $\left[2, \frac{5}{2} \right]$ c. $\left(2, \frac{5}{2} \right]$ d. $\left(2, \frac{5}{2} \right)$

21. $|5x - 3| \geq 7$ 21. _____
 a. $\left[-\frac{4}{5}, 2 \right]$ b. $(2, \infty)$
 c. $\left(-\infty, -\frac{4}{5} \right) \cup [2, \infty)$ d. $(-\infty, -2) \cup [7, \infty)$

Solve each problem.

22. A 60% alcohol solution is to be mixed with a 42% alcohol solution. 22. _____
 How many liters of the 60% solution should be used to make 30 liters of a 54% alcohol solution?
 a. 15 b. 18 c. 20 d. 10

23. Two cars leave at the same point at the same time traveling in opposite 23. _____
 directions. One travels 8 mph slower than the other. After 4 hr, they are 368 mi apart. Find the speed of the faster car.
 a. 42 mph b. 50 mph c. 60 mph d. 68 mph

CHAPTER 1, FORM E

24. The number y of people attending the Ozark Mountain Bluegrass Festival between 1989 and 1996 can be approximated by the model $y = 69.75x^2 - 328.7x + 1283$, where $x = 0$ corresponds to 1989. Based on this model, in what year was the festival attendance about 1800? 24. _____
- a. 1999 b. 1991 c. 1995 d. 1993
25. The height in feet of an object thrown upward is given by the equation $h = 80t - 16t^2$, where h is the height of the object after t seconds. After how many seconds will the object reach a height of 100 feet? 25. _____
- a. $1\frac{1}{2}$ sec b. 2 sec c. $2\frac{1}{2}$ sec d. sec

**CHAPTER 1, FORM F
COLLEGE ALGEBRA AND TRIGONOMETRY**

NAME _____
DATE _____

Choose the best answer.

Solve each equation.

1. $2(2x+3)+2(5x+4)=5+7(2x-1)$

- a. \emptyset b. $\left\{-\frac{3}{4}\right\}$ c. $\left\{-\frac{3}{2}\right\}$ d. $\left\{\frac{5}{4}\right\}$

1. _____

2. $\frac{2}{3}(2x+7)-\frac{3}{2}=\frac{1}{2}x-\frac{3}{4}x$

- a. $\{-2\}$ b. $\{1\}$ c. $\left\{\frac{5}{4}\right\}$ d. $\{0\}$

2. _____

3. $3x(x-4)=2x-9$

- a. $\left\{\frac{5\pm 2\sqrt{2}}{3}\right\}$ b. $\left\{\frac{5}{3}\pm\frac{2}{3}i\sqrt{2}\right\}$
c. $\left\{\frac{7\pm\sqrt{22}}{3}\right\}$ d. $\left\{\frac{7}{3}\pm\frac{1}{3}i\sqrt{22}\right\}$

3. _____

4. $\frac{2}{x^2-36}-\frac{1}{x-6}=\frac{1}{x+6}$

- a. $\{-1\}$ b. $\left\{-\frac{12}{5}\right\}$ c. $\{1\}$ d. $\left\{\frac{3}{2}\right\}$

4. _____

5. $15x^2=8x$

- a. $\{0\}$ b. $\left\{-\frac{8}{15}, \frac{8}{15}\right\}$
c. $\left\{0, \frac{8}{15}\right\}$ d. $\left\{-\frac{8}{15}, 0\right\}$

5. _____

6. $x-\sqrt{3x-2}=4$

- a. $\{2, 9\}$ b. $\{9\}$ c. $\{-1\}$ d. $\{1, 2\}$

6. _____

7. $\sqrt[3]{4x^2+3}=\sqrt[3]{x^2+10x}$

- a. $\{0, -10\}$ b. $\left\{-\frac{1}{3}, -3\right\}$ c. $\left\{\pm\frac{1}{2}i\sqrt{3}\right\}$ d. $\left\{\frac{1}{3}, 3\right\}$

7. _____

CHAPTER 1, FORM F

8. $x^4 + 4 = 5x^2$

- a. $\{\pm 1, \pm 2\}$ b. $\{\pm 1, \pm\sqrt{2}\}$
 c. $\{\pm i, \pm 2i\}$ d. $\{\pm 1, \pm 2i\}$

8. _____

9. $(3x-1)^2 + (3x-1) = 72$

- a. $\{9, -8\}$ b. $\{-9, 8\}$ c. $\left\{-\frac{7}{3}, \frac{10}{3}\right\}$ d. $\left\{-\frac{8}{3}, 3\right\}$

9. _____

10. $|3x+9| = 0$

- a. $\{-3, 3\}$ b. \emptyset c. $\{-3\}$ d. $\{3\}$

10. _____

11. $|3x+1| - 4 = -7$

- a. $\left\{-\frac{4}{3}\right\}$ b. $\left\{\frac{2}{3}, \frac{4}{3}\right\}$ c. $\left\{-\frac{4}{3}, -\frac{2}{3}\right\}$ d. \emptyset

11. _____

12. Solve the following equation for x : $4ax - 3by + 4 = 2cx + dz$

- a. $x = \frac{2c + dz}{4a - 3by + 4}$ b. $x = \frac{4a - 2c}{3by + dz - 4}$
 c. $x = \frac{4a - 3by + 4}{2c + dz}$ d. $x = \frac{3by + dz - 4}{4a - 2c}$

12. _____

Perform each operation. Give the answer in standard form.

13. $(5+3i) - (2-4i) - (3-8i)$

- a. $9i$ b. $6+7i$ c. $15i$ d. $6+15i$

13. _____

14. $(\sqrt{10} + 2i)(\sqrt{10} - 2i)$

- a. $10-4i$ b. $10+4i$ c. 14 d. 8

14. _____

15. $\frac{6+2i}{4+7i}$

- a. $-\frac{10}{33} + \frac{34}{33}i$ b. $-\frac{38}{33} + \frac{34}{33}i$ c. $\frac{38}{65} - \frac{34}{65}i$ d. $\frac{2}{13} - \frac{10}{13}i$

15. _____

CHAPTER 1, FORM F

16. Simplify the following power of i : i^{65} 16. _____
 a. i b. -1 c. $-i$ d. 1

Solve each inequality. Give the answer using interval notation.

17. $\frac{9x+8}{8} < \frac{64}{9}$ 17. _____
 a. $\left(\frac{440}{81}, \infty\right)$ b. $\left(\frac{64}{9}, \infty\right)$ c. $\left(-\infty, \frac{440}{81}\right)$ d. $\left(-\infty, \frac{64}{9}\right)$

18. $\frac{3x+4}{2x-1} \leq 0$ 18. _____
 a. $\left(-\infty, -\frac{4}{3}\right) \cup \left(\frac{1}{2}, \infty\right)$ b. $\left[-\frac{4}{3}, \frac{1}{2}\right)$
 c. $\left(-\frac{4}{3}, \frac{1}{2}\right)$ d. $\left[-\frac{4}{3}, \frac{1}{2}\right]$

19. $4x^2 < 20 + 11x$ 19. _____
 a. $\left(-\infty, -\frac{5}{4}\right) \cup (4, \infty)$ b. $\left(-\frac{5}{4}, 4\right)$
 c. $\left(-4, \frac{5}{4}\right)$ d. $(-\infty, -4) \cup \left(\frac{5}{4}, \infty\right)$

20. $|x+6|-9 > 12$ 20. _____
 a. $(-\infty, -23) \cup (-7, \infty)$ b. $(-\infty, -27) \cup (15, \infty)$
 c. $(-\infty, -7) \cup (23, \infty)$ d. $(-23, 11)$

21. $|3-2x| \leq 19$ 21. _____
 a. $[-8, 11]$ b. $(-8, 11)$ c. $(-\infty, -8)$ d. $(11, \infty)$

Solve each problem.

22. Two runners, Alma and Kim, leave home at the same time and jog in different directions. Alma travels east at a uniform rate that is 2 mph faster than Kim, who is traveling west. After 2 hr, they are 28 mi apart. Find Alma's rate. 22. _____
 a. 4 mph b. 6 mph c. 8 mph d. 10 mph

CHAPTER 1, FORM F

23. Mona can process 100 requests in 4 hr, and Jane can process 100 requests in twice the time. How long will it take both Mona and Jane, working together, to process 200 requests? 23. _____
- a. $2\frac{2}{3}$ hr b. 6 hr c. $3\frac{2}{3}$ hr d. $5\frac{1}{3}$ hr
24. The number y of fish in Silver Lake between 2000 and 2015 can be approximated by the model $f(x) = 1000(30 + 17x - x^2)$ where x corresponds to the year 2000. Based on this model, in what year was the fish population about 100,000? 24. _____
- a. 2005 b. 2007 c. 2010 d. 2012
25. The height in feet of an object thrown upward is given by the equation where h is the height of the object after t seconds. After how many seconds will the object reach a height of 36 feet? 25. _____
- a. $1\frac{1}{2}$ sec b. $2\frac{1}{2}$ sec c. 2 sec d. 5 sec

CHAPTER 2, FORM A
COLLEGE ALGEBRA AND TRIGONOMETRY

NAME _____
 DATE _____

1. Match the set described in Column I with the correct interval notation from Column II. Choices in Column II may be used once, more than once, or not at all.

- | I | II |
|--------------------------------------|------------------------|
| a. Domain of $f(x) = \sqrt{x-3}$ | A. $(-\infty, \infty)$ |
| b. Range of $f(x) = \sqrt{x} - 3$ | B. $[3, \infty)$ |
| c. Domain of $f(x) = x^2 - 16$ | C. $[0, 2]$ |
| d. Range of $y = 2x^2$ | D. $[0, \infty)$ |
| e. Domain of $f(x) = \sqrt[3]{x-2}$ | E. $[-3, 3]$ |
| f. Range of $f(x) = \sqrt[3]{x} + 2$ | F. $(-\infty, -2]$ |
| g. Domain of $f(x) = x+2 $ | G. $[-3, \infty)$ |
| h. Range of $f(x) = x +3$ | H. $[-7, \infty)$ |
| i. Domain of $y = 2s^2$ | |
| j. Range of $f(x) = x^2 - 7$ | |

1. a. _____
 b. _____
 c. _____
 d. _____
 e. _____
 f. _____
 g. _____
 h. _____
 i. _____
 j. _____

The graph shows the line that passes through the points $(-5, -3)$ and $(-1, 4)$. Refer to it to answer Exercises 2–6.

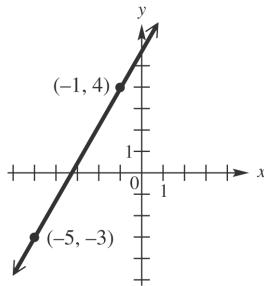

- | | |
|---|----------|
| 2. What is the slope of the line? | 2. _____ |
| 3. What is the distance between the two points shown? | 3. _____ |
| 4. What are the coordinates of the midpoint of the <i>segment</i> joining the two points? | 4. _____ |
| 5. Find the standard form of the equation of the line. | 5. _____ |
| 6. Write the linear function defined by $f(x) = ax + b$ that has this line as its graph. | 6. _____ |

CHAPTER 2, FORM A

Tell whether each graph is that of a function. Give the domain and the range. If it is a function, give the intervals where it is increasing, decreasing, or constant.

7.

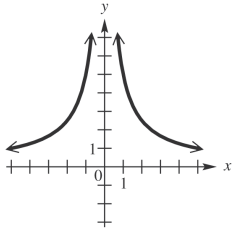

7. _____

8.

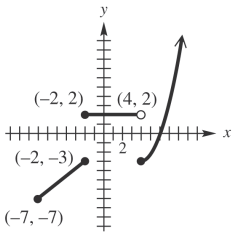

8. _____

9. Suppose point P has coordinates $\left(\frac{2}{5}, \frac{3}{7}\right)$.

- a. What is the equation of the vertical line through P ?
- b. What is the equation of the horizontal line through P ?

9. a. _____
 b. _____

10. Find the slope-intercept form of the equation of the line passing through $(2, 5)$ and

- a. parallel to the graph of $y = 4x - 7$;
- b. perpendicular to the graph of $y = 4x - 7$.

10. a. _____
 b. _____

Graph each relation.

11. $x = 2|y - 3| + 1$

11.

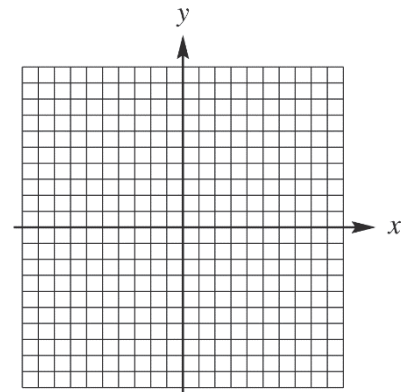

CHAPTER 2, FORM A

12. $f(x) = \lceil x \rceil + 2$

12.

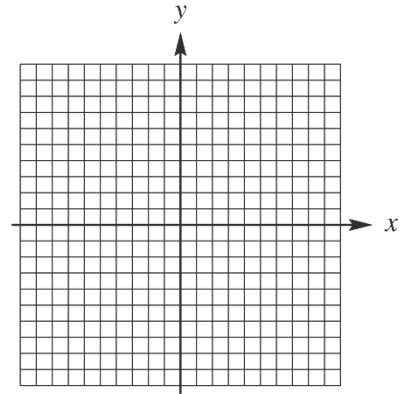

13. $f(x) = \begin{cases} 2x-1 & \text{if } x < 0 \\ -3x-1 & \text{if } x \geq 0 \end{cases}$

13.

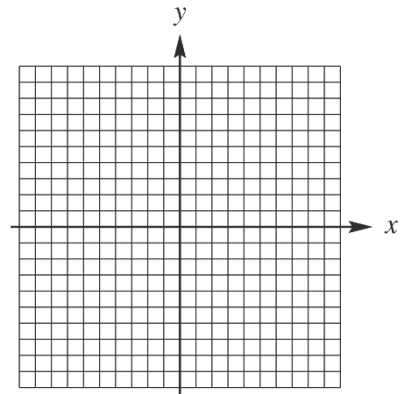

14. Explain how the graph of $y = -\frac{1}{2}\sqrt{x+3} + 5$ can be obtained from the graph of $y = \sqrt{x}$.

14. _____

15. Determine whether the graph of $2x^2 + 3y^2 = 1$ is symmetric with respect to

15. a. _____

a. the x-axis,

b. _____

b. the y-axis,

c. _____

c. the origin.

Given $f(x) = x^2 - 1$ and $g(x) = 2x + 1$, find each of the following. Simplify the expressions when possible.

16. $(fg)(x)$

16. _____

17. $(f+g)(x)$

17. _____

18. the domain of $\frac{g}{f}$

18. _____

CHAPTER 2, FORM A

19. $\frac{f(x+h) - f(x)}{h}$

19. _____

20. $(f - g)(0)$

20. _____

21. $\left(\frac{f}{g}\right)(2)$

21. _____

22. $(f \circ g)(x)$

22. _____

23. $(f \circ g)(-2)$

23. _____

24. $(g \circ f)(x)$

24. _____

25. $(g \circ f)(-2)$

25. _____

CHAPTER 2, FORM B
COLLEGE ALGEBRA AND TRIGONOMETRY

NAME _____
 DATE _____

1. Match the set described in Column I with the correct interval notation from Column II. Choices in Column II may be used once, more than once, or not at all.

- | I | II |
|--------------------------------------|------------------------|
| a. Domain of $f(x) = \sqrt{x-4}$ | A. $(-\infty, \infty)$ |
| b. Range of $f(x) = \sqrt{x} - 2$ | B. $[-2, \infty)$ |
| c. Domain of $f(x) = 3x^2$ | C. $[0, 2]$ |
| d. Range of $f(x) = x^2 + 5$ | D. $[0, \infty)$ |
| e. Domain of $f(x) = \sqrt[3]{x-8}$ | E. $[-3, 3]$ |
| f. Range of $f(x) = \sqrt[3]{x} - 1$ | F. $(-\infty, -2]$ |
| g. Domain of $f(x) = x-2 $ | G. $[5, \infty)$ |
| h. Range of $f(x) = x + 5$ | H. $[4, \infty)$ |
| i. Domain of $x = 2y^2$ | |
| j. Range of $x = 2y^2$ | |

1. a. _____
 b. _____
 c. _____
 d. _____
 e. _____
 f. _____
 g. _____
 h. _____
 i. _____
 j. _____

The graph shows the line that passes through the points $(-2, -1)$ and $(4, -3)$. Refer to it to answer Exercises 2–6.

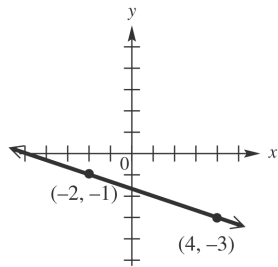

- | | |
|---|----------|
| 2. What is the slope of the line? | 2. _____ |
| 3. What is the distance between the two points shown? | 3. _____ |
| 4. What are the coordinates of the midpoint of the <i>segment</i> joining the two points? | 4. _____ |
| 5. Find the standard form of the equation of the line. | 5. _____ |
| 6. Write the linear function defined by $f(x) = ax + b$ that has this line as its graph. | 6. _____ |

CHAPTER 2, FORM B

Tell whether each graph is that of a function. Give the domain and the range. If it is a function, give the intervals where it is increasing, decreasing, or constant.

7.

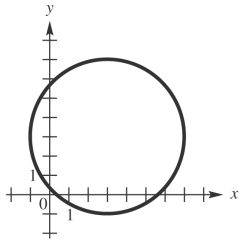

7. _____

8.

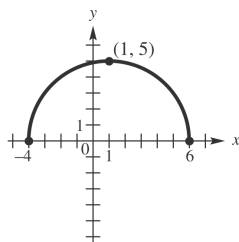

8. _____

Graph each relation.

9. $f(x) = 2 - |3x|$

9.

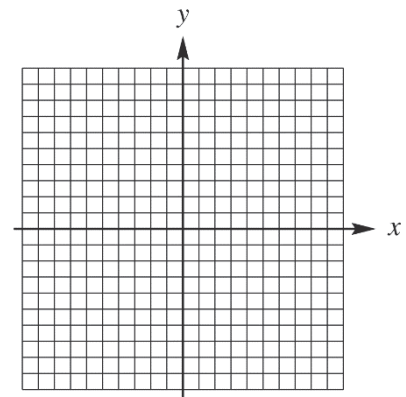

10. $f(x) = \left\lfloor \frac{1}{2}x \right\rfloor$

10.

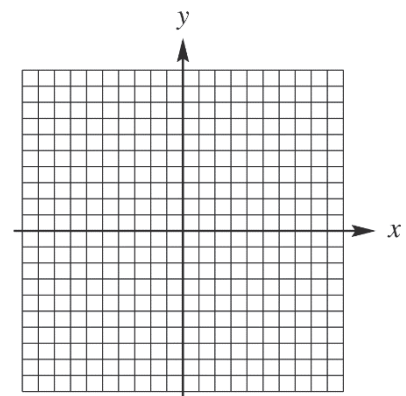

CHAPTER 2, FORM B

11.
$$f(x) = \begin{cases} -2x & \text{if } x < -3 \\ 4 & \text{if } -3 \leq x \leq 2 \\ x-4 & \text{if } x \geq 2 \end{cases}$$

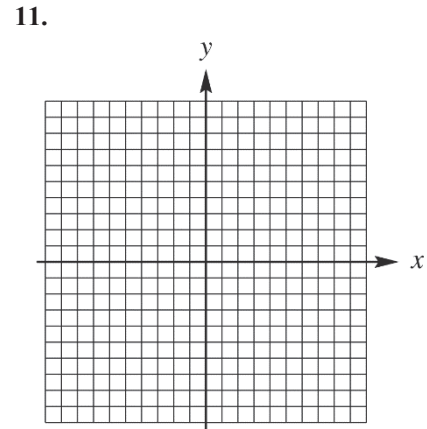

12. Suppose point P has coordinates $\left(\frac{5}{8}, -\frac{7}{9}\right)$.

- a. What is the equation of the vertical line through P ?
- b. What is the equation of the horizontal line through P ?

- 12. a. _____
- b. _____

13. Find the slope-intercept form of the equation of the line passing through $(-6, 3)$ and

- a. parallel to the graph of $y = -3x - 12$;
- b. perpendicular to the graph of $y = -3x - 12$.

- 13. a. _____
- b. _____

14. Explain how the graph of $y = -\frac{1}{3}\sqrt{x+4} + 2$ can be obtained from the graph of $y = \sqrt{x}$.

14. _____

15. Determine whether the graph of $y^2 = 3x$ is symmetric with respect to

- a. the x -axis,
- b. the y -axis,
- c. the origin.

- 15. a. _____
- b. _____
- c. _____

Given $f(x) = 2x^2 + 7x + 6$ and $g(x) = 3x - 2$, find each of the following. Simplify the expressions when possible.

16. $(fg)(x)$

16. _____

17. $(f - g)(x)$

17. _____

18. the domain of $\frac{g}{f}$

18. _____

CHAPTER 2, FORM B

19. $\frac{f(x+h) - f(x)}{h}$

19. _____

20. $(f + g)(1)$

20. _____

21. $\left(\frac{g}{f}\right)(0)$

21. _____

22. $(f \circ g)(x)$

22. _____

23. $(f \circ g)(1)$

23. _____

24. $(g \circ f)(x)$

24. _____

25. $(g \circ f)(1)$

25. _____

CHAPTER 2, FORM C
COLLEGE ALGEBRA AND TRIGONOMETRY

NAME _____
 DATE _____

1. Match the set described in Column I with the correct interval notation from Column II. Choices in Column II may be used once, more than once, or not at all.

- | I | II |
|--------------------------------------|------------------------|
| a. Domain of $f(x) = \sqrt{x+2}$ | A. $(-\infty, \infty)$ |
| b. Range of $f(x) = \sqrt{x} - 4$ | B. $[-4, \infty)$ |
| c. Domain of $f(x) = x^2 - 1$ | C. $[0, 2]$ |
| d. Range of $f(x) = x^2 - 16$ | D. $[0, \infty)$ |
| e. Domain of $f(x) = \sqrt[3]{x-2}$ | E. $[-3, 3]$ |
| f. Range of $f(x) = \sqrt[3]{x} + 2$ | F. $(-\infty, -3]$ |
| g. Domain of $f(x) = x+3 $ | G. $[-1, \infty)$ |
| h. Range of $f(x) = x -3$ | H. $[-2, \infty)$ |
| i. Domain of $y = 2x^2$ | |
| j. Range of $y = x^2 - 3$ | |

1. a. _____
 b. _____
 c. _____
 d. _____
 e. _____
 f. _____
 g. _____
 h. _____
 i. _____
 j. _____

The graph shows the line that passes through the points $(-3, -5)$ and $(3, -2)$. Refer to it to answer Exercises 2–6.

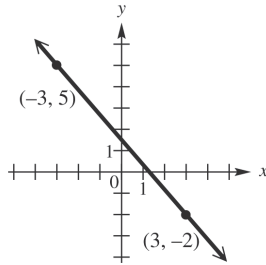

- | | |
|---|----------|
| 2. What is the slope of the line? | 2. _____ |
| 3. What is the distance between the two points shown? | 3. _____ |
| 4. What are the coordinates of the midpoint of the <i>segment</i> joining the two points? | 4. _____ |
| 5. Find the standard form of the equation of the line. | 5. _____ |
| 6. Write the linear function defined by $f(x) = ax + b$ that has this line as its graph. | 6. _____ |

CHAPTER 2, FORM C

Tell whether each graph is that of a function. Give the domain and the range. If it is a function, give the intervals where it is increasing, decreasing, or constant.

7.

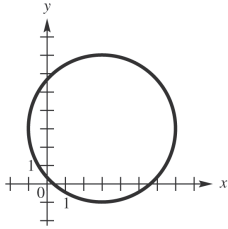

7. _____

8.

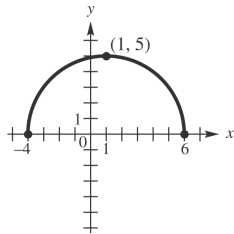

8. _____

9. Suppose point P has coordinates $(2\sqrt{2}, -\sqrt{5})$.

a. What is the equation of the vertical line through P ?

9. a. _____

b. What is the equation of the horizontal line through P ?

b. _____

10. Find the slope-intercept form of the equation of the line passing through $(4, -2)$ and

a. parallel to the graph of $x = \frac{5}{4}y - 2$;

10. a. _____

b. perpendicular to the graph of $x = \frac{5}{4}y - 2$;

b. _____

CHAPTER 2, FORM C

Graph each relation.

11. $f(x) = \frac{1}{2}|x+1| - 2$

11.

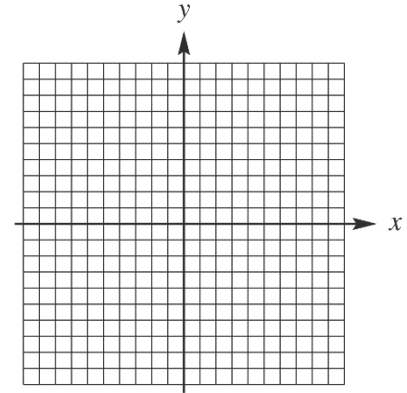

12. $f(x) = \llbracket 2x \rrbracket - 2$

12.

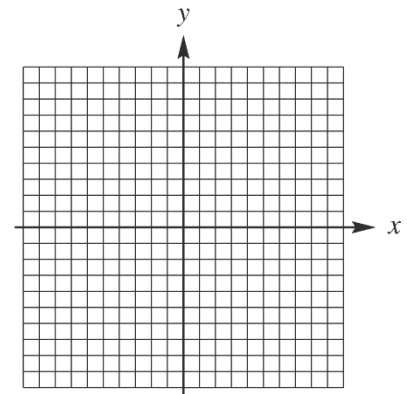

13. $f(x) = \begin{cases} x+1 & \text{if } x \leq -2 \\ -1 & \text{if } x > -2 \end{cases}$

13.

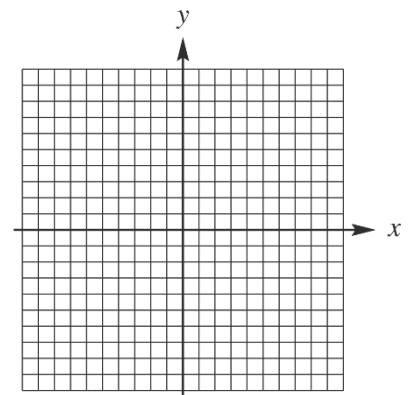

CHAPTER 2, FORM C

14. Explain how the graph of $y = 3|x + 4| + 2$ can be obtained from the graph of $y = |x|$. 14. _____

15. Determine whether the graph of $y = 3x^2 + 7$ is symmetric with respect to 15. a. _____

a. the x -axis, b. _____

b. the y -axis, c. _____

c. the origin.

Given $f(x) = 3x^2 - 2$ and $g(x) = 4x + 4$, find each of the following. Simplify the expressions when possible.

16. $(fg)(x)$ 16. _____

17. $(g - f)(x)$ 17. _____

18. $f(-2)$ 18. _____

19. $\frac{f(x+h) - f(x)}{h}$ 19. _____

20. $(f + g)(0)$ 20. _____

21. $\left(\frac{f}{g}\right)(-2)$ 21. _____

22. $(f - g)(x)$ 22. _____

23. $(f \circ g)(x)$ 23. _____

24. $(g \circ f)(x)$ 24. _____

25. $(g \circ f)(0)$ 25. _____

CHAPTER 2, FORM D
COLLEGE ALGEBRA AND TRIGONOMETRY

NAME _____
 DATE _____

1. Match the set described in Column I with the correct interval notation from Column II. Choices in Column II may be used once, more than once, or not at all.

- | I | II |
|--------------------------------------|------------------------|
| a. Domain of $f(x) = \sqrt{x+1}$ | A. $(-\infty, -1]$ |
| b. Range of $f(x) = \sqrt{x} + 1$ | B. $(-\infty, \infty)$ |
| c. Domain of $f(x) = x^2 - 25$ | C. $[0, 2]$ |
| d. Range of $f(x) = x^2 - 1$ | D. $[0, \infty)$ |
| e. Domain of $f(x) = \sqrt[3]{x-2}$ | E. $[-3, 3]$ |
| f. Range of $f(x) = \sqrt[3]{x} + 2$ | F. $[-3, \infty)$ |
| g. Domain of $f(x) = x+4 $ | G. $[-1, \infty)$ |
| h. Range of $f(x) = x - 4$ | H. $[-4, \infty)$ |
| i. Domain of $y = 2x^2$ | |
| j. Range of $y = x^2 - 4$ | |

1. a. _____
 b. _____
 c. _____
 d. _____
 e. _____
 f. _____
 g. _____
 h. _____
 i. _____
 j. _____

The graph shows the line that passes through the points $(-7, -4)$ and $(3, -2)$. Refer to it to answer Exercises 2–6.

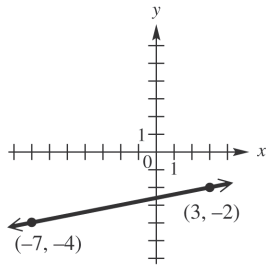

- | | |
|---|----------|
| 2. What is the slope of the line? | 2. _____ |
| 3. What is the distance between the two points shown? | 3. _____ |
| 4. What are the coordinates of the midpoint of the <i>segment</i> joining the two points? | 4. _____ |
| 5. Find the standard form of the equation of the line. | 5. _____ |
| 6. Write the linear function defined by $f(x) = ax + b$ that has this line as its graph. | 6. _____ |

CHAPTER 2, FORM D

Tell whether each graph is that of a function. Give the domain and the range. If it is a function, give the intervals where it is increasing, decreasing, or constant.

7.

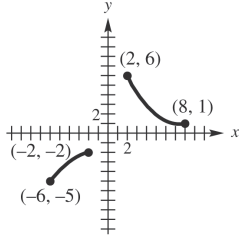

7. _____

8.

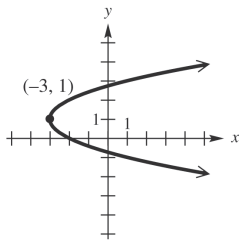

8. _____

Graph each relation.

9. $f(x) = 3 + |x + 1|$

9.

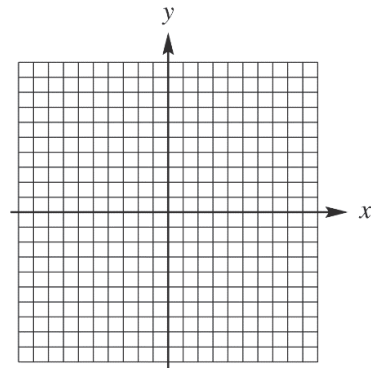

10. $f(x) = \begin{cases} -x & \text{if } x < 0 \\ 2x & \text{if } x \geq 0 \end{cases}$

10.

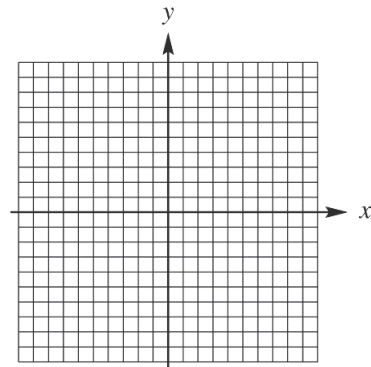

CHAPTER 2, FORM D

11. Suppose point P has coordinates $(-3, 2.1)$.
- a. What is the equation of the vertical line through P ? 11. a. _____
- b. What is the equation of the horizontal line through P ? b. _____
12. Find the slope-intercept form of the equation of the line passing through $(1, -5)$ and
- a. parallel to the graph of $x = -\frac{3}{4}y + 5$; 12. a. _____
- b. perpendicular to the graph of $x = -\frac{3}{4}y + 5$; b. _____
13. Find the slope of the line through points $(11, -5)$ and $(-8, 6)$. 13. _____
 from the graph of $y = \sqrt{x}$.
14. Explain how the graph of $y = 3\sqrt{x-4} - 2$ can be obtained 14. _____
 from the graph of $y = \sqrt{x}$.
15. Determine whether the graph of $xy = -4$ is symmetric 15. a. _____
 with respect to b. _____
- a. the x -axis, c. _____
- b. the y -axis,
- c. the origin.

Given $f(x) = 2x^3 - 3x - 1$ and $g(x) = 2x + 1$, find each of the following. Simplify the expressions when possible.

16. $(f + g)(x)$ 16. _____
17. $\left(\frac{f}{g}\right)(x)$ 17. _____
18. $f(0)$ 18. _____
19. $\frac{f(x+h) - f(x)}{h}$ 19. _____
20. $(g - f)(0)$ 20. _____
21. $(fg)(-1)$ 21. _____
22. $(f \circ g)(x)$ 22. _____

CHAPTER 2, FORM D

23. $(f \circ g)(2)$

24. $(g \circ f)(x)$

25. $(g \circ f)(2)$

23. _____

24. _____

25. _____

**CHAPTER 2, FORM E
COLLEGE ALGEBRA AND TRIGONOMETRY**

NAME _____
DATE _____

Choose the best answer.

- 1a. Which of the following is the domain of $f(x) = \sqrt{3-x}$? 1a. _____
- a. $[0, 3]$ b. $(-\infty, 3]$
c. $[3, \infty)$ d. $(-\infty, \infty)$
- 1b. Which of the following is the range of $f(x) = x^2 - 49$? 1b. _____
- a. $[-49, \infty)$ b. $[-7, \infty)$
c. $[-7, 7]$ d. $[0, \infty)$
- 1c. Which of the following is the domain of $f(x) = \sqrt[3]{x+7}$? 1c. _____
- a. $(-\infty, \infty)$ b. $(-\infty, 6]$
c. $[0, \infty)$ d. $[6, \infty)$
- 1d. Which of the following is the range of $f(x) = |x| + 1$? 1d. _____
- a. $[-1, 1]$ b. $[0, 1]$
c. $[0, \infty)$ d. $[1, \infty)$
- 1e. Which of the following is the domain of $x = y^2$? 1e. _____
- a. $(-\infty, \infty)$ b. $[0, \infty)$
c. $(0, \infty)$ d. $(-\infty, 0]$

The graph shows the line that passes through $(-5, 8)$ and $(4, -3)$. Refer to it to answer Exercises 2-6.

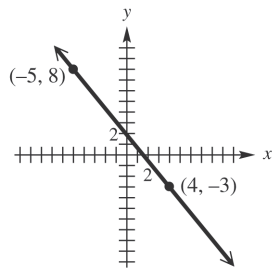

2. What is the slope of the line? 2. _____
- a. $-\frac{13}{7}$ b. $\frac{11}{9}$
c. $-\frac{11}{9}$ d. 0
3. What is the distance between the two points shown? 3. _____
- a. $\sqrt{26}$ b. $2\sqrt{5}$
c. $\sqrt{202}$ d. $\sqrt{122}$

CHAPTER 2, FORM E

4. What are the coordinates of the midpoint of the segment joining the two points?

- a. $\left(-\frac{1}{2}, \frac{5}{2}\right)$ b. $\left(-\frac{9}{2}, \frac{11}{2}\right)$
 c. $\left(\frac{3}{2}, \frac{1}{2}\right)$ d. $(-1, 5)$

4. _____

5. Find the standard form of the equation of the line.

- a. $11x + 9y = 127$ b. $11x - 9y = 17$
 c. $11x + 9y = 17$ d. $11x - 9y = 127$

5. _____

6. Find the standard form of the equation of the line.

- a. $f(x) = \frac{11}{9}x - \frac{17}{9}$ b. $f(x) = -\frac{11}{9}x + \frac{17}{9}$
 c. $f(x) = \frac{11}{9}x + \frac{127}{9}$ d. $f(x) = \frac{11}{9}x - \frac{127}{9}$

6. _____

Tell whether each graph is that of a function. Give the domain and range.

7.

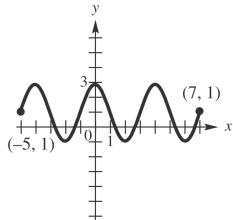

7. _____

- a. Function; domain: $[-5, 7]$; range: $[-1, 3]$
 b. Function; domain: $(-\infty, \infty)$; range: $[-1, 3]$
 c. Function; domain: $[-1, 3]$; range: $[-5, 7]$
 d. Not a function; domain: $[-5, 7]$; range: $[-1, 3]$

8.

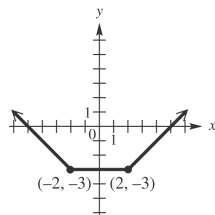

8. _____

- a. Not a function; domain: $(-\infty, \infty)$; range: $[-2, \infty)$
 b. Not a function; domain: $[-5, 5]$; range: $[-3, \infty)$
 c. Function; domain: $(-\infty, \infty)$; range: $[-2, \infty)$
 d. Function; domain: $(-\infty, \infty)$; range: $[-3, \infty)$

CHAPTER 2, FORM E

9. Suppose point P has coordinates $(-6, 1)$.

What is the equation of the horizontal line through P ?

- a. $x = -6$ b. $y = 1$
 c. $x = 1$ d. $y = 6$

9. _____

10. Find the slope-intercept form of the equation of the line passing.

through $(-2, 5)$ perpendicular to the graph of $y = -\frac{1}{8}x + \frac{19}{4}$.

- a. $y = 8x + 21$ b. $y = \frac{1}{3}x - 3$
 c. $y = -8x - 13$ d. $y = -\frac{1}{3}x + 3$

10. _____

Graph each function.

11. $f(x) = 2|x - 1| - 2$

11. _____

a.

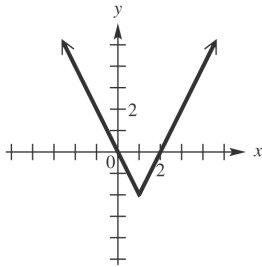

b.

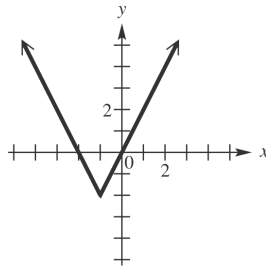

c.

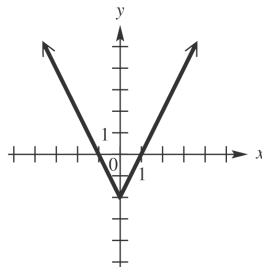

d.

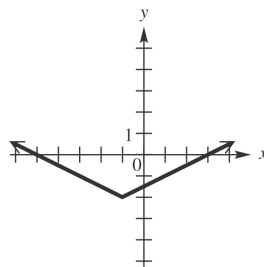

CHAPTER 2, FORM E

12. $f(x) = \left\lfloor \frac{1}{2}x \right\rfloor$

12. _____

a.

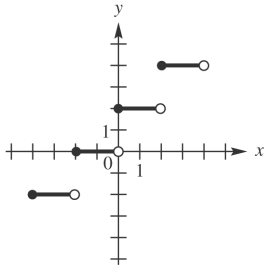

b.

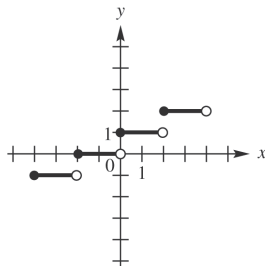

c.

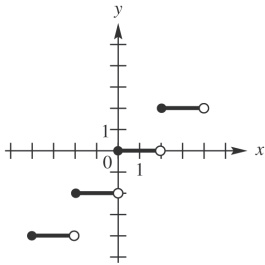

d.

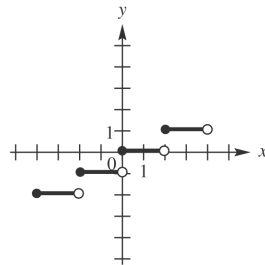

13. $f(x) = \begin{cases} 2 & \text{if } x < -2 \\ -\frac{1}{2}x + 1 & \text{if } x \geq -2 \end{cases}$

13. _____

a.

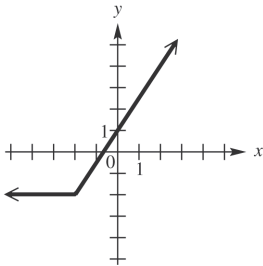

b.

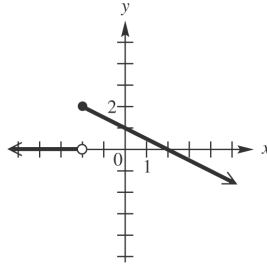

c.

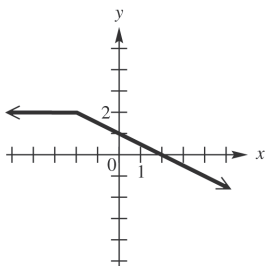

d.

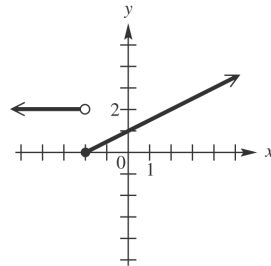

CHAPTER 2, FORM E

14. Explain how the graph of $y = \sqrt{x+2} - 5$ can be obtained from the graph of $y = \sqrt{x}$. 14. _____
- Translate 2 unit to the right and 5 units up.
 - Translate 2 unit to the right and 5 units down.
 - Translate 2 unit to the left and 5 units up.
 - Translate 2 unit to the left and 5 units down.

15. Determine the symmetries of the graph of the relation $x^2 - 2xy + y^2 = 5$. 15. _____
- x -axis only
 - y -axis only
 - origin only
 - x -axis, y -axis, and origin

Given $f(x) = 5x - 4$ and $g(x) = x^2 + 3$, find each of the following. Simplify the expressions when possible.

16. $(fg)(x)$ 16. _____
- $x^3 + 4x^2 - 12$
 - $5x^3 - 4x^2 + 15x - 12$
 - $5x^3 + 4x^2 + 3x - 12$
 - $-5x^3 + 4x^2 - 5x - 12$

17. $(g - f)(x)$ 17. _____
- $x^2 - 5x + 7$
 - $x^2 + 5x - 7$
 - $-x^2 - 5x + 1$
 - $x^2 + 5x + 1$

18. The domain of $\frac{g}{f}$ 18. _____
- $\left(-\infty, \frac{4}{5}\right) \cup \left(\frac{4}{5}, \infty\right)$
 - $\left(-\infty, \frac{5}{4}\right) \cup \left(\frac{5}{4}, \infty\right)$
 - $\left(-\infty, \frac{1}{3}\right) \cup \left(\frac{1}{3}, \infty\right)$
 - $(-\infty, \infty)$

19. $\frac{f(x+h) - f(x)}{h}$ 19. _____
- h
 - 5
 - $5x + 2h$
 - $5x + 2h - 4$

20. $(f + g)(-1)$ 20. _____
- -1
 - -5
 - 2
 - 5

CHAPTER 2, FORM E

21. $\left(\frac{f}{g}\right)(0)$

a. $-\frac{3}{4}$

b. $\frac{1}{4}$

c. $-\frac{4}{3}$

d. $\frac{15}{2}$

21. _____

22. $(g \circ f)(x)$

a. $25x^2 + 40x - 19$

b. $25x^2 - 40x + 19$

c. $25x^2 - 40x - 19$

d. $25x^2 + 40x + 19$

22. _____

23. $(g \circ f)(1)$

a. -6

b. 4

c. 0

d. 1

23. _____

24. $(f \circ g)(x)$

a. $5x^2 - 11$

b. $5x^2 + 11$

c. $5x^2 + 19$

d. $5x^2 - 12$

24. _____

25. $(f \circ g)(0)$

a. -1

b. 0

c. 11

d. 15

25. _____

**CHAPTER 2, FORM F
COLLEGE ALGEBRA AND TRIGONOMETRY**

NAME _____
DATE _____

Choose the best answer.

- 1a. Which of the following is the domain of $f(x) = \sqrt{x-1}$? 1a. _____
- a. $[0,1]$ b. $(-\infty,1]$
c. $[1,\infty)$ d. $(-\infty,\infty)$
- 1b. Which of the following is the range of $f(x) = x^2 - 4$? 1b. _____
- a. $[-2,\infty)$ b. $[-4,\infty)$
c. $[-4,4]$ d. $[0,\infty)$
- 1c. Which of the following is the domain of $f(x) = \sqrt[3]{x-7}$? 1c. _____
- a. $(-\infty,\infty)$ b. $(-\infty,3]$
c. $[0,\infty)$ d. $[3,\infty)$
- 1d. Which of the following is the range of $f(x) = |x| + 2$? 1d. _____
- a. $[-2,2]$ b. $[0,2]$
c. $[2,\infty)$ d. $[0,\infty)$
- 1e. Which of the following is the domain of $x = y^2$? 1e. _____
- a. $(-\infty,\infty)$ b. $[0,\infty)$
c. $(0,\infty)$ d. $(-\infty,0]$

The graph shows the line that passes through $(-7, -4)$ and $(3, -2)$. Refer to it to answer Exercises 2-6.

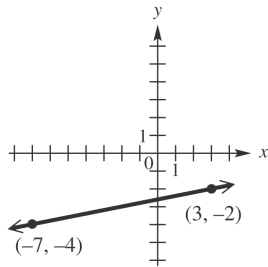

2. What is the slope of the line? 2. _____
- a. 0 b. $-\frac{1}{5}$
c. $\frac{1}{5}$ d. 5
3. What is the distance between the two points shown? 3. _____
- a. $\sqrt{122}$ b. $2\sqrt{26}$
c. $2\sqrt{13}$ d. $2\sqrt{34}$

CHAPTER 2, FORM F

4. What are the coordinates of the midpoint of the *segment* joining the two points?

- a. $\left(\frac{1}{2}, -\frac{11}{2}\right)$ b. $(-2, -1)$
 c. $(-5, -1)$ d. $(-2, -3)$

4. _____

5. Find the standard form of the equation of the line.

- a. $5x - y = 17$ b. $5x + y = -17$
 c. $x - 5y = 13$ d. $x + 5y = -13$

5. _____

6. Find the standard form of the equation of the line.

- a. $f(x) = \frac{1}{5}x - \frac{13}{5}$ b. $f(x) = -5x + 17$
 c. $f(x) = 5x - 17$ d. $f(x) = \frac{1}{5}x + \frac{13}{5}$

6. _____

Tell whether each graph is that of a function. Give the domain and range.

7.

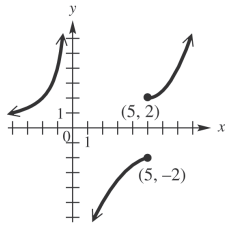

7. _____

- a. not a function; domain: $(-\infty, 0) \cup (0, \infty)$; range: $(-\infty, -2] \cup (0, \infty)$
 b. not a function; domain: $(-\infty, \infty)$; range: $(-\infty, \infty)$
 c. not a function; domain: $(-\infty, 0) \cup (0, \infty)$; range: $(-\infty, \infty)$
 d. not a function; domain: $(-\infty, 0) \cup (0, \infty)$; range: $(-\infty, -2] \cup (2, \infty)$

8.

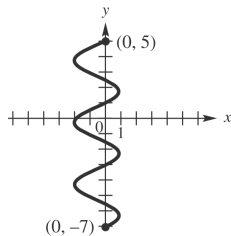

8. _____

- a. not a function; domain: $[-2, 1]$; range: $(-\infty, \infty)$
 b. not a function; domain: $[-7, 5]$; range: $[-2, 1]$
 c. not a function; domain: $[-7, 5]$; range: $(-\infty, \infty)$
 d. not a function; domain: $[-2, 1]$; range: $[-7, 5]$

CHAPTER 2, FORM F

9. Suppose point P has coordinates $(-3, 6)$.

What is the equation of the horizontal line through P ?

- a. $x = -3$ b. $y = -3$
 c. $x = 6$ d. $y = 6$

9. _____

10. Find the slope-intercept form of the equation of the line passing

through $(1, 2)$ perpendicular to the graph of $y = -\frac{1}{8}x + \frac{1}{3}$.

- a. $y = 8x - 3$ b. $y = \frac{1}{8}x - \frac{1}{3}$
 c. $y = -8x + 3$ d. $y = -\frac{1}{8}x + \frac{17}{8}$

10. _____

Graph each relation.

11. $f(x) = \frac{1}{2}|x+1|$

11. _____

a.

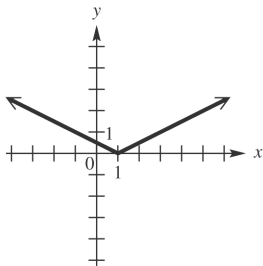

b.

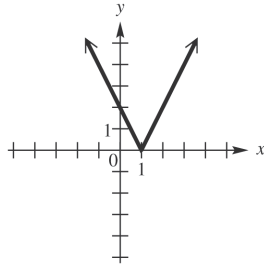

c.

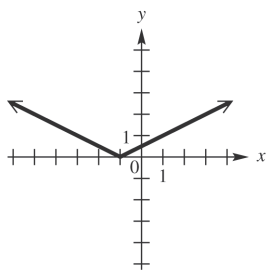

d.

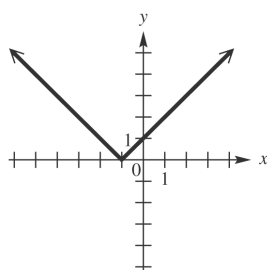

CHAPTER 2, FORM F

12. $f(x) = \left\lfloor \frac{1}{2}x \right\rfloor - 2$

a.

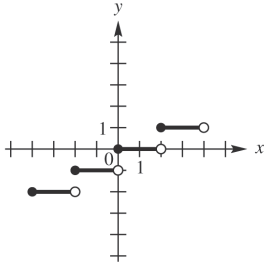

b.

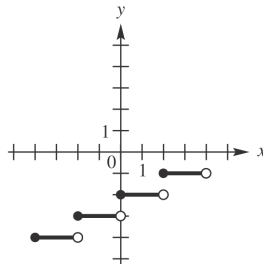

c.

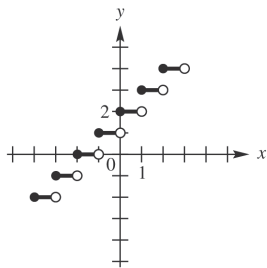

d.

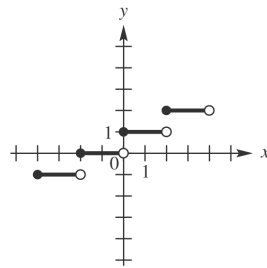

12. _____

13. $f(x) = \begin{cases} -2x & \text{if } x < -1 \\ x+3 & \text{if } x \geq -1 \end{cases}$

a.

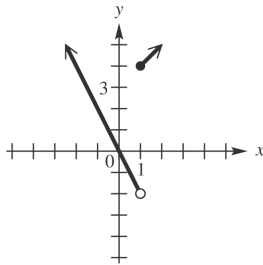

b.

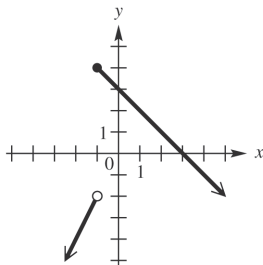

c.

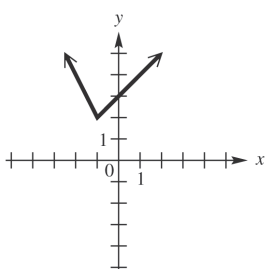

d.

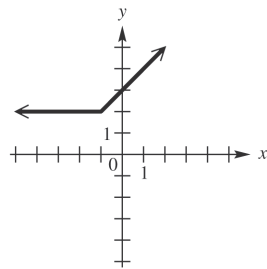

13. _____

14. Explain how the graph of $y = \sqrt{x+3} + 1$ can be obtained from the graph of $y = \sqrt{x}$.

- a. Translate 3 units to the right and 1 units up.
- b. Translate 3 units to the right and 1 units down.
- c. Translate 3 units to the left and 1 units up.
- d. Translate 3 units to the left and 1 units down.

14. _____

CHAPTER 2, FORM F

15. Determine the symmetries of the graph of the relation $4x^2 + 9y^2 = 36$.

- a. x -axis only b. y -axis only
 c. Origin only d. x -axis, y -axis, and origin

15. _____

Given $f(x) = 6x^2 + 5x - 6$ and $g(x) = 2x - 8$, find each of the following.
 Simplify the expressions when possible.

16. $f(-3)$

- a. -9 b. 21
 c. 33 d. 51

16. _____

17. $\frac{f(x+h) - f(x)}{h}$

- a. $12x + 6h + 5$ b. $12x - 6h - 5$
 c. $-12x + 6h + 5$ d. $-12x + 6h - 5$

17. _____

18. $(f \circ g)\left(\frac{3}{2}\right)$

- a. -131 b. 119
 c. -181 d. 169

18. _____

19. $(f + g)(x)$

- a. $6x^2 + 7x - 14$ b. $6x^2 - 7x - 14$
 c. $6x^2 + 7x - 2$ d. $6x^2 - 3x - 2$

19. _____

20. $(f + g)(0)$

- a. -15 b. -14
 c. -27 d. 1

20. _____

CHAPTER 3, FORM A
COLLEGE ALGEBRA AND TRIGONOMETRY

NAME _____
 DATE _____

1. Sketch the graph of the quadratic function $f(x) = -3x^2 - 6x - 5$. Give the intercepts, the vertex, the axis, the domain, and the range.

1.

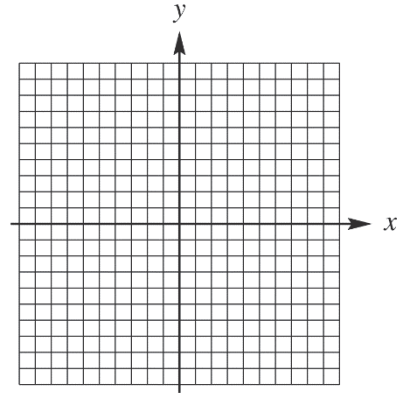

x-intercepts: _____
 y-intercepts: _____
 vertex: _____
 axis: _____
 domain: _____
 range: _____

2. A rock is propelled upward from the top of a building 60 feet tall at an initial velocity of 40 feet per second. The function that describes the height of the rock in terms of time t is $f(t) = 16t^2 + 40t + 60$. Determine the maximum height that the rock reaches.

2. _____

Use synthetic division to perform each division.

3.
$$\frac{x^5 - 4x^4 + 20x^3 - 14x^2 + 14x + 12}{x - 1}$$

3. $q(x)$: _____
 r : _____

4.
$$\frac{5x + x^4 - 14x^2}{x + 4}$$

4. $q(x)$: _____
 r : _____

5. Use synthetic division to determine $f(3)$, if $f(x) = 3x^5 - 4x^3 - 5x^2 + 2$.

5. _____

CHAPTER 3, FORM A

6. Use the factor theorem to determine whether the polynomial $x - 2$ is a factor of $3x^5 - 4x^2 - 5x^3 - 8x + 25$.

If it is, what is the other factor?
If it is not, explain why.

7. Find all zeros of $f(x)$, given that $f(x) = x^3 - 8x^2 - x + 8$ and 1 is one zero.

8. $f(x)$ is a third degree polynomial having only real coefficients. It has 5 and $-i$ as zeros, and the point $(-2, 105)$ lies on the graph. Find $f(x)$.

9. Consider the function defined by $f(x) = -2x^3 - 3x^2 + 5x + 4$.

- a. Use the intermediate value theorem to show that f has a zero between 0 and -1 .
b. Use a graphing calculator to find all real zeros to as

10. Explain why the polynomial function defined by $f(x) = 2x^6 + 4x^2 + 8$ cannot have any real zeros.

many decimal places as the calculator will give.

11. Graph the functions defined by $f_1(x) = x^4$ and $f_2(x) = -\frac{1}{2}(x-1)^4 + 2$ on the same axes. Explain how the graph of f_2 can be obtained by a translation of the graph of f_1 .

6. _____

7. _____

8. _____

9. a. _____

b. _____

10. _____

11.

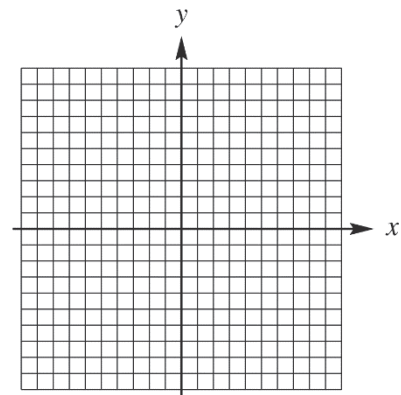

CHAPTER 3, FORM A

12. Use end behavior to determine which of the following graphs is that of $f(x) = x^9 - 2x^2 + 3$.

12. _____

a.

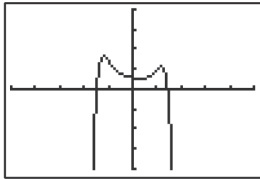

b.

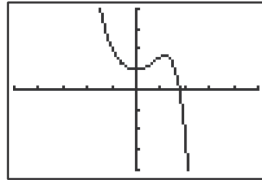

c.

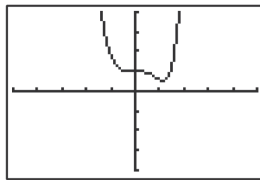

d.

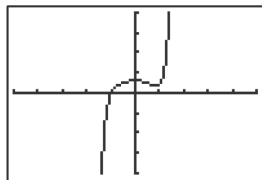

Graph each polynomial function. Factor first if the expression is not in factored form.

13. $f(x) = (x+1)(x-2)(x-4)$

13. _____

14. $f(x) = (x-1)(x-3)(x+2)^2$

14. _____

15. $f(x) = -x^4 + 2x^3 - 2x^2$

15. _____

16. Find a cubic polynomial having the graph shown.

16. _____

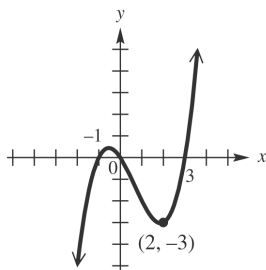

17. Based on information provided by the U.S. Institute on Drug Abuse, the percent y of 18- to 25-year-olds who had used hallucinogens between 1974 and 1991 can be modeled by the function $y = .025x^3 - .7x^2 + 4.43x + 16.77$, where $x = 0$ corresponds to the year 1974. In what year during this period did this type of drug use reach its minimum?

17. _____

CHAPTER 3, FORM A

18. $f(x) = \frac{3}{x+1}$

18.

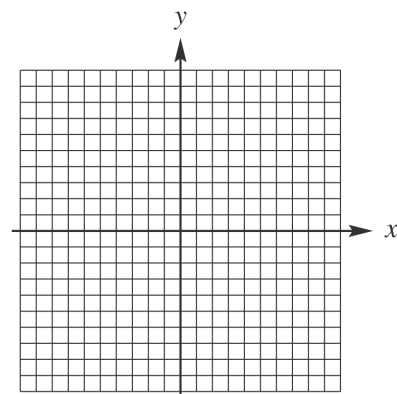

19. $f(x) = \frac{x^2 + 2}{x^2 - 4}$

19.

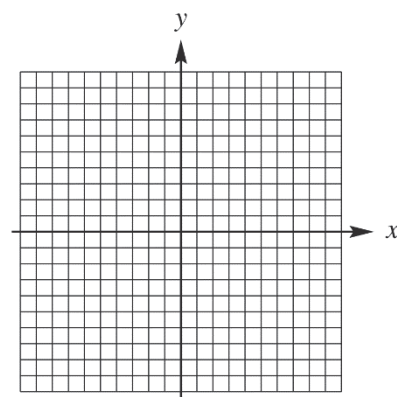

CHAPTER 3, FORM A

20. For the rational function defined by $f(x) = \frac{x^2 - 4}{x}$,
- determine the equation of the oblique asymptote;
 - determine the x -intercepts;
 - determine the y -intercepts;
 - determine the equation of the vertical asymptote;
 - sketch the graph.

20. a. _____
 b. _____
 c. _____
 d. _____
 e. _____

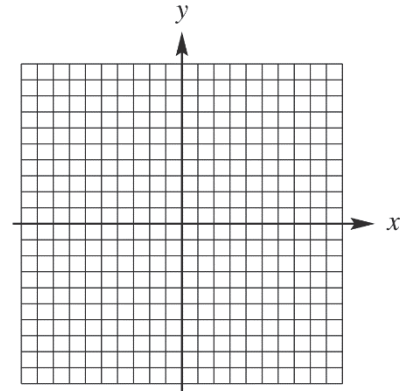

21. The pressure of a gas varies jointly as its density and its absolute temperature. When the density of a gas is .75 g per cubic liter and the absolute temperature is 400° , the pressure is 20 newtons per sq m. Find the pressure per cubic liter when the density is 4.00 g per cubic liter and the absolute temperature is 60° .
22. The illumination (in foot-candles) of a light source varies directly as the intensity (in candle-power) of the source and inversely as the square of the distance from the source. If a certain light source with intensity of 300 candle-power provides an illumination of 2.5 foot-candles at a distance of 40 ft, what is the illumination at a distance of 20 ft?

21. _____
22. _____

CHAPTER 3, FORM B
COLLEGE ALGEBRA AND TRIGONOMETRY

NAME _____
 DATE _____

1. Sketch the graph of the quadratic function $f(x) = -3x^2 - 6x - 1$. Give the intercepts, the vertex, the axis, the domain, and the range.

1.

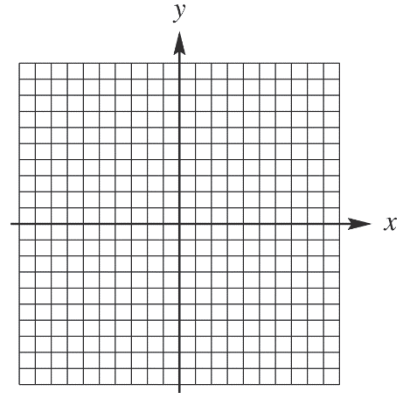

x-intercepts: _____
 y-intercepts: _____
 vertex: _____
 axis: _____
 domain: _____
 range: _____

2. Joe owns a hotdog stand. He has found that his profit can be approximated by the model $P(x) = -x^2 + 60x + 76$, where P is the profit (in dollars) and x is the number of hotdogs sold.
- Based on this model, what is his profit if he sells 45 hotdogs?
 - Find the number of hotdogs he must sell to earn the maximum profit. What is the maximum profit?

2. a. _____
 b. _____

Use synthetic division to perform each division.

3.
$$\frac{4x^4 - 3x^3 - x + 5}{x - 3}$$

3. $q(x)$: _____
 r : _____

4.
$$\frac{x^4 - 4x^3 - 15x^2 + 19x - 6}{x - 6}$$

4. $q(x)$: _____
 r : _____

5. Use synthetic division to determine $f(3)$, if $f(x) = -x^3 - 3x^2 + 5$.

5. _____

CHAPTER 3, FORM B

6. Use the factor theorem to determine whether the polynomial $x+3$ is a factor of $2x^5 + 3x^4 - 10x^3 + x^2 + 6x - 18$.
If it is, what is the other factor?
If it is not, explain why.

6. _____

7. Find all zeros of $f(x)$, given that $f(x) = x^3 + 3x^2 - 10x - 24$ and 3 is one zero.

7. _____

8. $f(x)$ is a fourth degree polynomial having only real coefficients. It has $-4, -i,$ and 2 as zeros, and the point $(-3, 50)$ lies on the graph. Find $f(x)$.

8. _____

9. Consider the function defined by $f(x) = x^3 - 2x^2 - 5x + 4$.

- a. Use the intermediate value theorem to show that f has a zero between -1 and -2 .
- b. Use a graphing calculator to find all real zeros to as many decimal places as the calculator will give.

9. a. _____

b. _____

10. Explain why the polynomial function defined by $f(x) = -5x^6 - 7x^2 - 2$ cannot have any positive real zeros.

10. _____

11. Graph the functions defined by $f_1(x) = x^3$ and $f_2(x) = -2(x-3)^3 + 2$ on the same axes. Explain how the graph of f_2 can be obtained by a translation of the graph of f_1 .

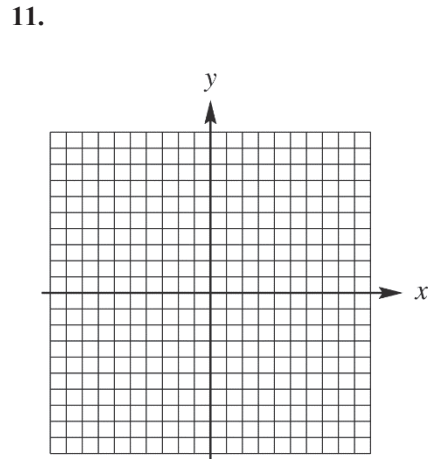

CHAPTER 3, FORM B

12. Use end behavior to determine which of the following graphs is that of $f(x) = x^7 + 3x^3 + 5$.

12. _____

a.

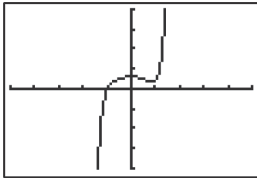

b.

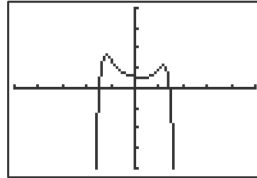

c.

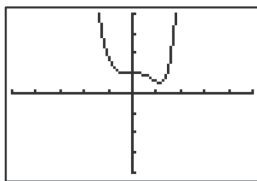

d.

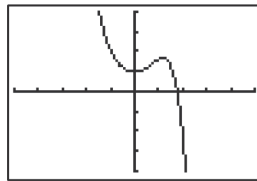

Graph each polynomial function. Factor first if the expression is not in factored form.

13. $f(x) = \frac{1}{3}x^5 - \frac{2}{3}x^4 + \frac{1}{3}x^3$

13. _____

14. $f(x) = (x+1)(x-1)(x+2)(x+3)$

14. _____

15. $f(x) = x(x-3)(x+2)(x-2)$

15. _____

16. Find a cubic polynomial having the graph shown.

16. _____

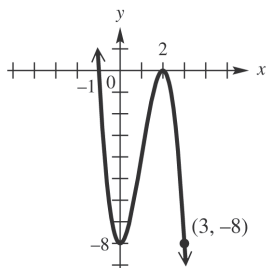

17. Based on information provided by the U.S. Institute on Drug Abuse, the percent y of 18- to 25-year-olds who had used hallucinogens between 1974 and 1991 can be modeled by the function $y = .025x^3 - .7x^2 + 4.43x + 16.77$, where $x = 0$ corresponds to the year 1974. In what year during this period did this type of drug use reach its minimum? (Round to the nearest whole year.)

17. _____

CHAPTER 3, FORM B

18. $f(x) = \frac{x^2 - 16}{x^2 - 4}$

18.

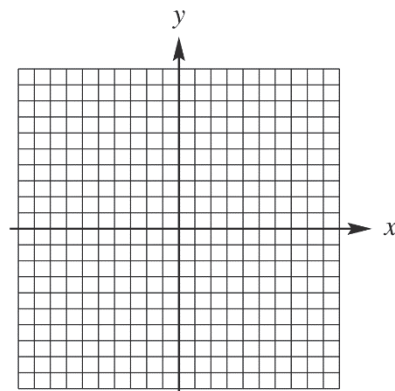

19. $f(x) = \frac{6}{x^2 + 4}$

19.

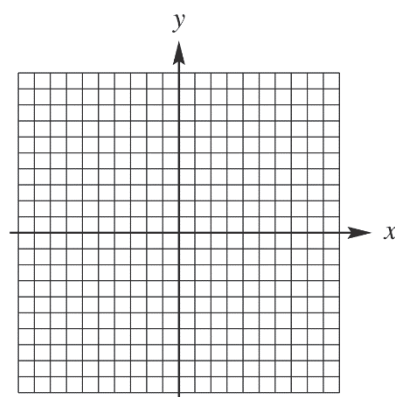

CHAPTER 3, FORM B

20. For the rational function defined by $f(x) = \frac{x^2 - 9}{x + 4}$,

- a. determine the equation of the oblique asymptote;
- b. determine the x -intercepts;
- c. determine the y -intercepts;
- d. determine the equation of the vertical asymptote;
- e. sketch the graph.

- 20. a. _____
- b. _____
- c. _____
- d. _____
- e. _____

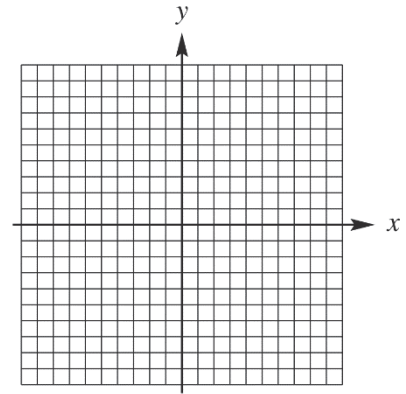

21. The electrical resistance of a wire varies directly as its length and inversely as the square of its diameter. If the resistance of 640 ft of copper wire $\frac{1}{4}$ in. in diameter is 16 ohms, find the resistance of 320 ft of the same type of copper wire $\frac{1}{2}$ in. in diameter.

21. _____

22. Hooke's Law for an elastic spring states that the distance a spring stretches varies directly as the force is applied. If a force of 25 pounds stretches a certain spring 7 inches, then how much will a force of 100 pounds stretch the spring?

22. _____

CHAPTER 3, FORM C
COLLEGE ALGEBRA AND TRIGONOMETRY

NAME _____
 DATE _____

1. Sketch the graph of the quadratic function
 $f(x) = -\frac{1}{2}x^2 - 4x - 6$. Give the intercepts, the vertex, the axis, the domain, and the range.

1.

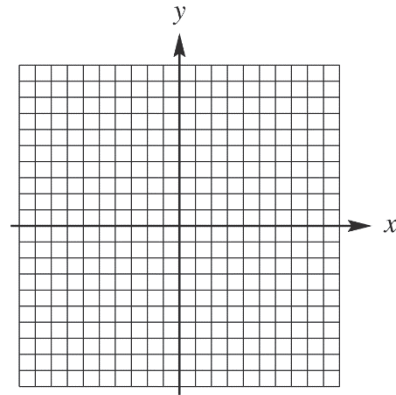

x-intercepts: _____
 y-intercepts: _____
 vertex: _____
 axis: _____
 domain: _____
 range: _____

2. Melissa sells umbrellas. She finds that her profit can be approximated by the model $P(x) = -2x^2 + 92x + 110$, where P is the profit in dollars and x is the number of batons sold.
- Based on this model, what is her profit if she sells 40 umbrellas?
 - Find the number of umbrellas she must sell to earn the maximum profit. What is the maximum profit?

2. a. _____
 b. _____

Use synthetic division to perform each division.

3.
$$\frac{5x^3 - 10x^2 + 8x + 10}{x + 1}$$

3. $q(x)$: _____
 r : _____

4.
$$\frac{x^5 - 1}{x - 1}$$

4. $q(x)$: _____
 r : _____

5. Use synthetic division to determine $f(-3)$, if
 $f(x) = x^4 - 8x^3 + 14x^2 + 8x - 15$.

5. _____

CHAPTER 3, FORM C

6. Use the factor theorem to determine whether the polynomial $x+2$ is a factor of $4x^4 - 3x + 2x^2 - 5x + 8$.
If it is, what is the other factor?
If it is not, explain why.

6. _____

7. Find all zeros of $f(x)$, given that $f(x) = 4x^3 - 12x^2 - x + 3$ and 3 is one zero.

7. _____

8. $f(x)$ is a fourth degree polynomial having only real coefficients. It has 3, -4, and $-i$ as zeros, and the point $(-3, -120)$ lies on the graph. Find $f(x)$.

8. _____

9. Consider the function defined by $f(x) = 2x^3 + 5x^2 - 7x + 1$.

a. Use the intermediate value theorem to show that f has a zero between -3 and -4 .

9. a. _____

b. Use a graphing calculator to find all real zeros to as many decimal places as the calculator will give.

b. _____

10. Explain why the polynomial function defined by $f(x) = x^4 + 4x^2$ has only one real zero.

10. _____

11. Graph the functions defined by $f_1(x) = x^4$ and $f_2(x) = \frac{1}{2}(x+2)^4 - 1$ on the same axes. Explain how the graph of f_2 can be obtained by a translation of the graph of f_1 .

11.

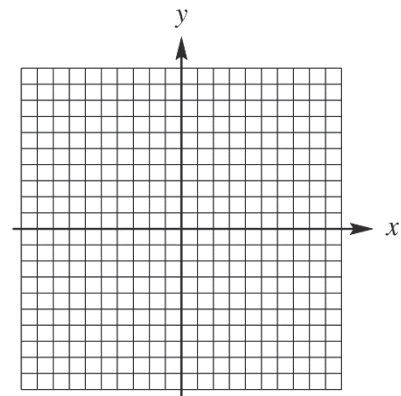

CHAPTER 3, FORM C

12. Use end behavior to determine which of the following graphs is that of $f(x) = x^6 - 3x^3 + 5$.

12. _____

a.

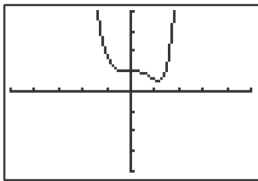

b.

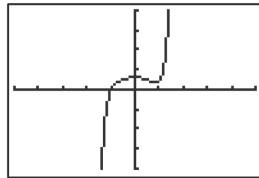

c.

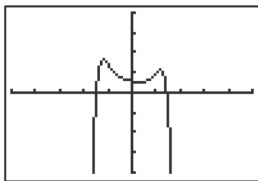

d.

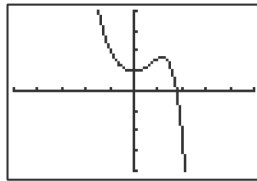

Graph each polynomial function. Factor first if the expression is not in factored form.

13. $f(x) = x(x+2)(x-1)(x+4)$

13. _____

14. $f(x) = (x+3)(x+1)(x-2)^2$

14. _____

15. $f(x) = 3x^4 + 12x^3 + 12x^2$

15. _____

16. Find a cubic polynomial having the graph shown.

16. _____

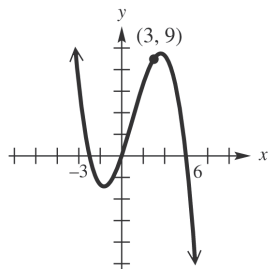

17. A technique for measuring cardiac output depends on the concentration of a dye in the bloodstream after a known amount is injected into a vein near the heart. For a normal heart, the concentration of dye in the bloodstream at the time x (in seconds) is modeled by the function

17. _____

$$g(x) = -.006x^4 + .140x^3 - .053x^2 + 1.79x.$$

According to this model, how long after the injection does the concentration reach its maximum? (Round to the nearest tenth of a second.)

CHAPTER 3, FORM C

18. $f(x) = \frac{3}{2-x}$

18.

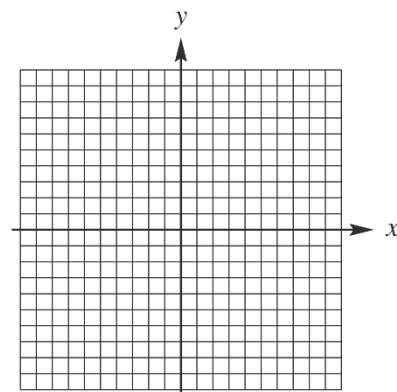

19. $f(x) = \frac{4-2x}{x+2}$

19.

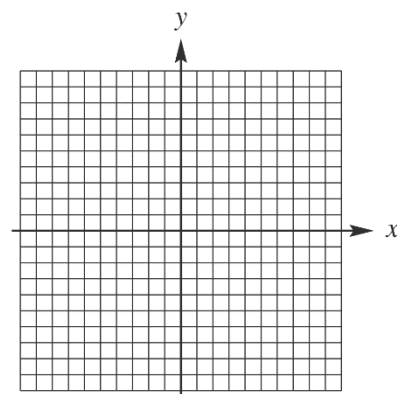

CHAPTER 3, FORM C

20. For the rational function defined by $f(x) = \frac{x^2 + 2x - 8}{x + 3}$,

- a. determine the equation of the oblique asymptote;
- b. determine the x -intercepts;
- c. determine the y -intercept;
- d. determine the equation of the vertical asymptote;
- e. sketch the graph.

- 20. a. _____
- b. _____
- c. _____
- d. _____
- e. _____

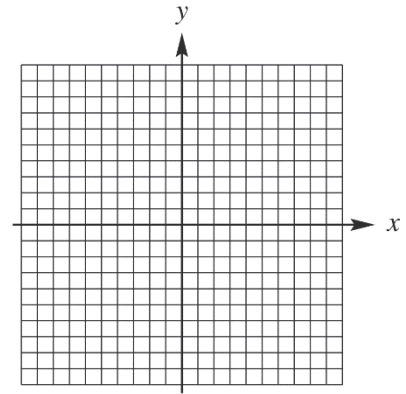

21. The weight of a liquid varies directly as its volume V . If the weight of the liquid into a cubical container 4 cm on a side is 192 g, find the weight of the liquid in a cubical container 5 cm on a side.

21. _____

22. The elongation in a wire when a mass is hung at its free end varies jointly as the mass and the length of the wire and inversely as the cross-sectional area of the wire. The elongation is .0072 cm when a mass of 160 gm is attached to a wire 330 cm long, with a cross-sectional area of .4 sq cm. Find the elongation if a mass of 120 gm is attached to the same wire.

22. _____

CHAPTER 3, FORM D
COLLEGE ALGEBRA AND TRIGONOMETRY

NAME _____
 DATE _____

1. Sketch the graph of the quadratic function
 $f(x) = \frac{1}{3}x^2 - 4x + 16$. Give the intercepts, the vertex, the axis, the domain, and the range.

1.

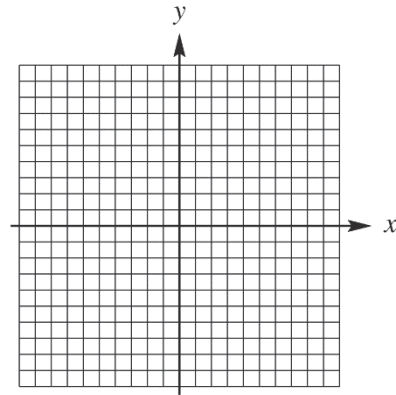

x-intercepts: _____
 y-intercepts: _____
 vertex: _____
 axis: _____
 domain: _____
 range: _____

2. If a model rocket is fired upward from ground level, its position s (in feet) above the ground at any time t (in seconds) is given by the function
 $s(t) = 160t - 16t^2$.
- a. Find the height of the rocket 3 sec after it is fired.
- b. Find the maximum height of the rocket and the time it takes the rocket to reach that height.

2. a. _____
 b. _____

Use synthetic division to perform each division.

3. $\frac{3x^4 - 8x^3 + 10x + 3}{x - 2}$

3. $q(x)$: _____
 r : _____

4. $\frac{-5x - 13x^2 - x + 10}{x + 2}$

4. $q(x)$: _____
 r : _____

5. Use synthetic division to determine $f(2)$, if
 $f(x) = x^6 + 3x^5 + 2x^4 + 3x^3 - 2x^2 + 5x + 5$.

5. _____

CHAPTER 3, FORM D

6. Use the factor theorem to determine whether the polynomial $x - 4$ is a factor of $x^4 - 2x^3 - 13x^2 + 24x - 16$.
If it is, what is the other factor?
If it is not, explain why.

6. _____

7. Find all zeros of $f(x)$, given that
 $f(x) = (x^2 + 13x + 36)^2$

7. _____

8. $f(x)$ is a third degree polynomial having only real coefficients. It has 1, 3 and -4 as zeros, and the point $(-2, 30)$ lies on the graph. Find $f(x)$.

8. _____

9. Consider the function defined by $f(x) = -x^3 + 4x^2 + 5x - 6$.

- a. Use the intermediate value theorem to show that f has a zero between 4 and 5.
b. Use a graphing calculator to find all real zeros to as many decimal places as the calculator will give.

9. a. _____

b. _____

10. Explain why the polynomial function defined by $f(x) = 2x^4 + 7x^2 + 12$ has no real zero.

10. _____

11. Graph the functions defined by $f_1(x) = x^3$ and $f_2(x) = 2(x - 3)^3 + 1$ on the same axes. Explain how the graph of f_2 can be obtained by a translation of the graph of f_1 .

11.

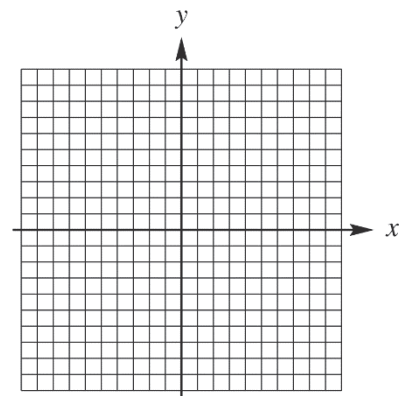

CHAPTER 3, FORM D

12. Use end behavior to determine which of the following graphs is that of $f(x) = x^8 + 4x^4 - x + 3$.

12. _____

a.

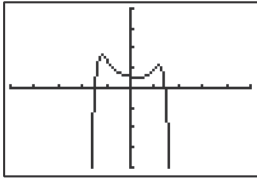

b.

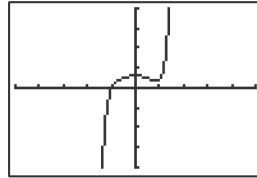

c.

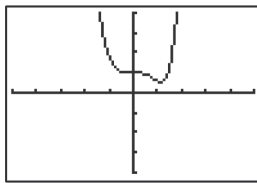

d.

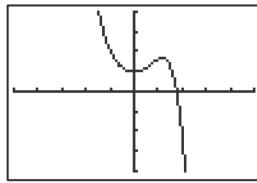

Graph each polynomial function. Factor first if the expression is not in factored form.

13. $f(x) = x(3x-1)(x-1)(x-2)$

13. _____

14. $f(x) = -x(x-3)(x+2)(x-2)$

14. _____

15. $f(x) = 2x^4 - 8x^3 - 8x^2$

15. _____

16. Find a cubic polynomial having the graph shown.

16. _____

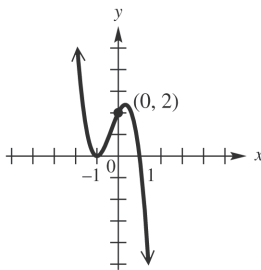

17. A technique measuring cardiac output depends on the concentration of a dye in the bloodstream after a known amount is injected into a vein near the heart. For a normal heart, the concentration of dye in the bloodstream at time x (in seconds) is modeled by the function

17. _____

$$g(x) = -.006x^4 + .140x^3 - .053x^2 + 1.79x.$$

According to this model, during what period of time is the concentration increasing? (Round to the nearest tenth of a second.)

CHAPTER 3, FORM D

18. $f(x) = \frac{-4}{x+3}$

18.

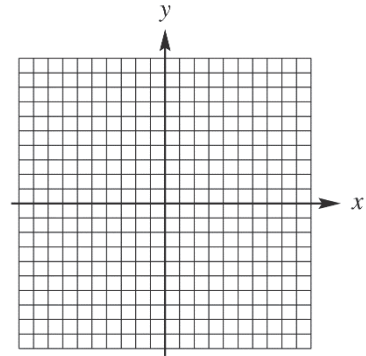

19. $f(x) = \frac{3}{x^2 - 4}$

19.

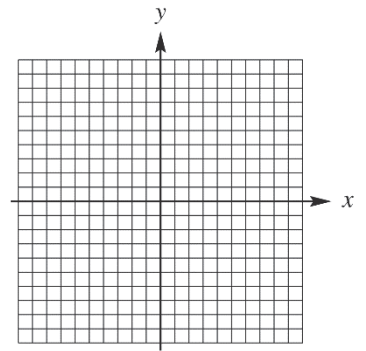

20. For the rational function defined by $f(x) = \frac{x^2 - 2x + 1}{x - 3}$,

- a. determine the equation of the oblique asymptote;
- b. determine the x -intercepts;
- c. determine the y -intercept;
- d. determine the equation of the vertical asymptote;
- e. sketch the graph.

20. a. _____
 b. _____
 c. _____
 d. _____
 e. _____

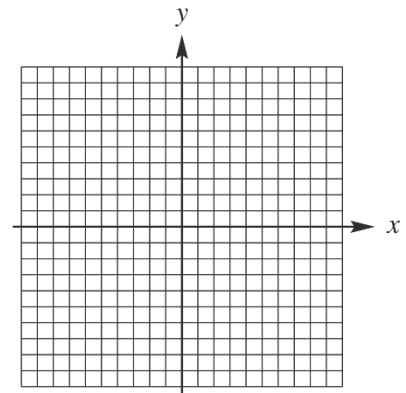

CHAPTER 3, FORM D

21. The intensity I of light varies inversely as the square of the distance D from the source. If the intensity of illumination on a screen 5 ft from a light is 2 foot candles, find the intensity on a screen 15 ft from the light.

21. _____

22. The pitch P of a musical tone varies inversely as its wavelength W . One tone has a pitch of 382 vibrations per second and a wavelength of 18.9 ft. Find the wavelength of another tone that has a pitch of 474 vibrations per second.

22. _____

CHAPTER 3, FORM E
COLLEGE ALGEBRA AND TRIGONOMETRY

NAME _____
 DATE _____

Choose the best answer.

1. Give the axis and vertex of the graph of $f(x) = (x+4)^2 + 10$. 1. _____
 - a. Axis: $x = -4$; vertex: $(-4, -10)$
 - b. Axis: $x = -4$; vertex: $(-4, 10)$
 - c. Axis: $x = 4$; vertex: $(4, 10)$
 - d. Axis: $x = 4$; vertex: $(-4, 10)$

2. A ball is thrown downward from a window in a tall building. Its position at time t in seconds is $s = 16t^2 + 32t$, where s is in feet. How long (to the nearest tenth) will it take the ball to fall 90 feet? 2. _____
 - a. 1.6 sec
 - b. 1.8 sec
 - c. 2.4 sec
 - d. 2.6 sec

3. Use synthetic division to perform the division. 3. _____

$$\frac{x^3 - x^2 + 7}{x + 2}$$
 - a. $x^2 + 3x + 6 + \frac{5}{x+2}$
 - b. $x^2 - 3x + 6 - \frac{5}{x+2}$
 - c. $x^2 - 3x + 6 + \frac{6}{x+2}$
 - d. $x^2 - 2x + 6 + \frac{6}{x+2}$

4. Use synthetic division to determine $f(-2)$, if $f(x) = 4x^3 - 3x^2 - 5x + 9$. 4. _____
 - a. -39
 - b. 19
 - c. -25
 - d. -46

5. Which of the following is a factor of $-9x^3 + 2x^2 + x - 10$? 5. _____
 - a. $x + 10$
 - b. $x - 10$
 - c. $x + 1$
 - d. $x - 1$

6. Use synthetic division to determine the remainder r : $\frac{7x^3 - 3x^2 - 5x + 1}{x + 1}$ 6. _____
 - a. -4
 - b. 2
 - c. 4
 - d. 10

7. Find all rational zeros of the function $f(x) = 2x(x - 6)(x + 11)$. 7. _____
 - a. 0, 6, 11
 - b. -11, 6, 11
 - c. -11, -6, 0
 - d. -11, 0, 6

CHAPTER 3, FORM E

8. $f(x)$ is a third degree polynomial having only real coefficients. It has 3, i , and $-i$ as zeros, and the point (2, 25) lies on the graph. Find $f(x)$.
- $f(x) = x^3 - 3x^2 + x - 3$
 - $f(x) = -5x^3 + 15x^2 - 5x + 15$
 - $f(x) = -5x^3 + 15x^2 + 5x - 15$
 - $f(x) = 5x^3 - 15x^2 - 5x + 15$
8. _____
-
9. Show that the polynomial function $f(x) = 5x^4 - 10x - 12$ has no real zero greater than 2.
- When $f(x)$ is divided by $x - 2$, the alternating signs in the bottom row indicate an upper bound.
 - When $f(x)$ is divided by $x + 2$, the alternating signs in the bottom row indicate an upper bound.
 - When $f(x)$ is divided by $x + 2$, the bottom row with all signs nonnegative indicates an upper bound.
 - When $f(x)$ is divided by $x - 2$, the bottom row with all signs nonnegative indicates an upper bound.
9. _____
-
10. Consider the function defined by $f(x) = 7x^3 + 2x^2 - 3x + 10$. Use the intermediate value theorem to find two consecutive integers between which f has a zero.
- 1, 0
 - 2, -1
 - 0, 1
 - 1, 2
10. _____
-
11. The functions $f_1(x) = (x+1)^3$ and $f_2(x) = (x-4)^3 + 2$ are graphed on the same axes. Explain how the graph of f_2 can be obtained by a translation of the graph of f_1 .
- Shift the graph 6 units left and 2 units up.
 - Shift the graph 6 units right and 2 units down.
 - Shift the graph 5 units right and 2 units down.
 - Shift the graph 5 units left and 2 units up.
11. _____

CHAPTER 3, FORM E

12. Use end behavior to determine which of the following graphs is that of $f(x) = x^4 - 5x^2 - 10$.

12. _____

a.

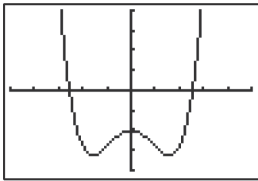

b.

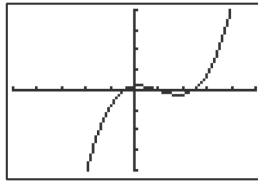

c.

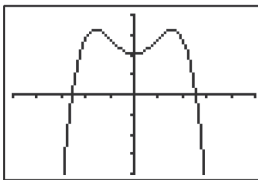

d.

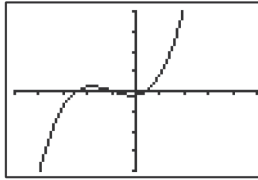

Graph each polynomial function.

13. $f(x) = x(x-3)(x+2)(x-2)$

13. _____

a.

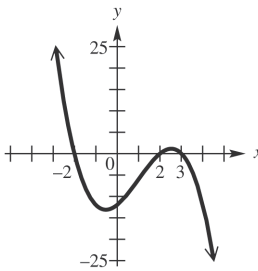

b.

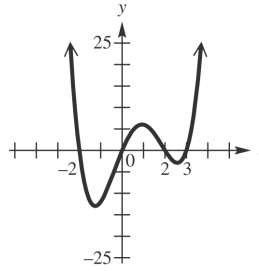

c.

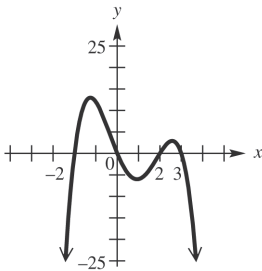

d.

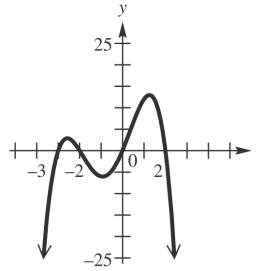

CHAPTER 3, FORM E

14. Factor $f(x) = x^3 - 2x^2 - 36x + 72$ given that 6 is a zero of $f(x)$.

- a. $f(x) = x(x-2)(x+6)$
- b. $f(x) = (x-6)(x-2)(x+6)$
- c. $f(x) = (x-6)(x-2)(x+2)$
- d. $f(x) = (x-6)(x+2)(x+6)$

14. _____

15. Use a graphing calculator to find a real zero that is approximate to the nearest tenth for this polynomial.

$$f(x) = x^3 - x + 2$$

- a. 2.1
- b. 1.9
- c. -1.5
- d. No real zeros

15. _____

16. Find a cubic polynomial having the graph shown.

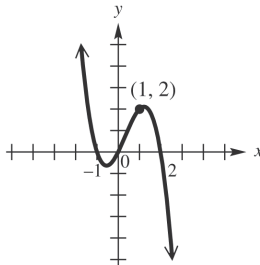

- a. $f(x) = -x^3 + x^2 + 2x$
- b. $f(x) = x^3 - x^2 - 2x$
- c. $f(x) = 2x^3 - 2x^2 - 4x$
- d. $f(x) = -2x^3 + 2x^2 + 4x$

16. _____

17. Which one of the functions defined below has a graph with no x -intercepts?

- a. $f(x) = \frac{1}{x-2}$
- b. $f(x) = \frac{x+1}{x-3}$
- c. $f(x) = \frac{x}{x-1}$
- d. $f(x) = -2x^2 - 8x - 3$

17. _____

CHAPTER 3, FORM E

Graph each rational function.

18. $f(x) = \frac{2}{1-x}$

18. _____

a.

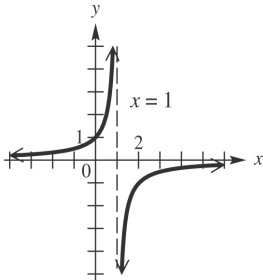

b.

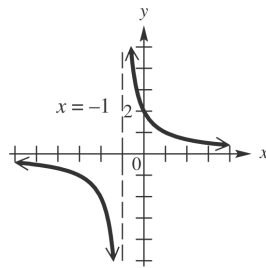

c.

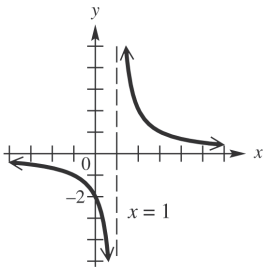

d.

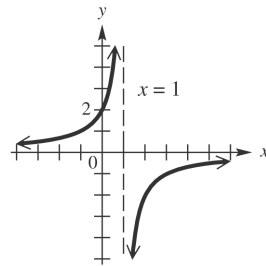

19. $f(x) = \frac{4-x^2}{2+x}$

19. _____

a.

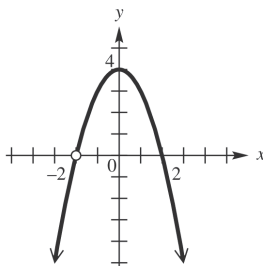

b.

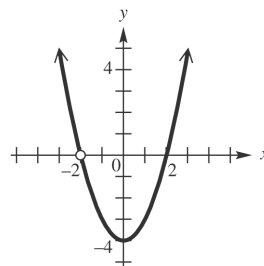

c.

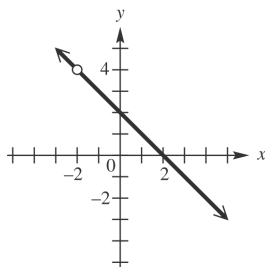

d.

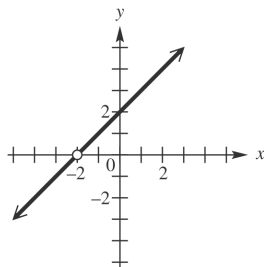

CHAPTER 3, FORM E

20. For the rational function defined by $f(x) = \frac{x^2 - 7x - 9}{x - 4}$, determine the equation of the oblique asymptote. 20. _____
- a. $y = x + 3$ b. $y = x - 3$
c. $y = x + 11$ d. $y = x - 11$
21. For a fixed period of time, the amount of interest varies jointly as the principal and the interest rate. If a principal of \$2000 invested at a rate of 6% earns \$300 in interest, how much interest will a principal of \$4000 earn if it is invested at 8%? 21. _____
- a. \$8000 b. \$800
c. \$80 d. \$1600
22. The speed of a gear varies directly as the number of teeth it contains. If a gear with 10 teeth rotates at 240 rpm, with what speed would a gear with 18 teeth revolve under the same conditions? 22. _____
- a. 432 rpm b. 480 rpm
c. 133 rpm d. 672 rpm

CHAPTER 3, FORM F
COLLEGE ALGEBRA AND TRIGONOMETRY

NAME _____
 DATE _____

Choose the best answer.

1. Give the axis and vertex of the graph of $f(x) = 4x^2 - 16x + 19$. 1. _____
 - a. Axis: $x = 2$; vertex: $(2, 3)$
 - b. Axis: $x = 2$; vertex: $(2, -3)$
 - c. Axis: $x = \frac{1}{2}$; vertex: $(\frac{1}{2}, 3)$
 - d. Axis: $x = \frac{1}{2}$; vertex: $(\frac{1}{2}, -3)$

2. The height in feet of an object thrown upward is given by the equation $h = 48t - 16t^2$, where h is the height of the object after t seconds. Find the maximum height the object reaches. 2. _____
 - a. $\frac{3}{2}$ ft
 - b. 28 ft
 - c. 36 ft
 - d. 144 ft

3. Use synthetic division to determine $f(-4)$, if 3. _____

$$\frac{-6x^3 + 2x^2 + 5x - 10}{x - 2}$$
 - a. $-6x^2 - 10x - 15 - \frac{25}{x - 2}$
 - b. $-6x^2 - 10x - 15 - \frac{40}{x - 2}$
 - c. $-6x^2 - 10x - 25 - \frac{40}{x - 2}$
 - d. $-6x^2 - 10x - 5 - \frac{10}{x - 2}$

4. Use synthetic division to determine $f(-4)$, if 4. _____

$$f(x) = 4x^3 + 12x^2 - 8x + 25.$$
 - a. 7
 - b. 3
 - c. -1
 - d. -7

5. Which of the following is a factor of 5. _____

$$5x^3 - 9x^2 + x + 219?$$
 - a. $x + 3$
 - b. $x + 73$
 - c. $x - 73$
 - d. $x - 3$

6. Use synthetic division to determine the remainder r : 6. _____

$$\frac{2x^3 + 3x^2 - 18x - 4}{x - 2}$$
 - a. 0
 - b. 7
 - c. -12
 - d. -14

7. Find all rational zeros of the function $f(x) = 4x^3 - 12x^2 - x + 3$. 7. _____
 - a. $-\frac{1}{2}, \frac{1}{2}, 3$
 - b. $-3, -2, 3$
 - c. $-\frac{1}{2}, \frac{3}{2}, 3$
 - d. $1, 2, \frac{5}{2}$

CHAPTER 3, FORM F

8. $f(x)$ is a fourth degree polynomial having only real coefficients. It has -1 , 3 , and i as zeros, and the point $(2, -30)$ lies on the graph. Find $f(x)$.
8. _____
- a. $f(x) = x^4 - 2x^3 - 2x^2 - 2x - 3$
 - b. $f(x) = x^4 - x^2 - 5x - 3$
 - c. $f(x) = 2x^4 - 4x^3 - 4x^2 - 4x - 6$
 - d. $f(x) = 2x^4 + 4x^3 - 2x^2 + 4x - 6$
9. Show that the polynomial function $f(x) = 2x^3 - 7x^2 + 4x + 1$ has no real zero greater than -2 .
9. _____
- a. When $f(x)$ is divided by $x + 2$, the alternating signs in the bottom row indicate a lower bound.
 - b. When $f(x)$ is divided by $x - 2$, the alternating signs in the bottom row indicate a lower bound.
 - c. When $f(x)$ is divided by $x + 2$, the bottom row with all signs nonnegative indicates a lower bound.
 - d. When $f(x)$ is divided by $x - 2$, the bottom row with all signs nonnegative indicates a lower bound.
10. Consider the function defined by $f(x) = 8x^4 - 4x^3 - 5x - 9$. Use the intermediate value theorem to find two consecutive integers between which f has a zero.
10. _____
- a. $-1, 0$
 - b. $2, 3$
 - c. $0, 1$
 - d. $3, 4$
11. The functions $f_1(x) = -2(x - 3)^4$ and $f_2(x) = -2(x + 1)^4 - 5$ are graphed on the same axes. Explain how the graph of f_2 can be obtained by a translation of the graph of f_1 .
11. _____
- a. Shift the graph 1 unit left and 5 units down.
 - b. Shift the graph 1 unit right and 5 units up.
 - c. Shift the graph 4 units right and 5 units down.
 - d. Shift the graph 4 units left and 5 units down.

CHAPTER 3, FORM F

12. Use end behavior to determine which of the following graphs is that of $f(x) = x^3 - 3x^2 + x + 1$.

12. _____

a.

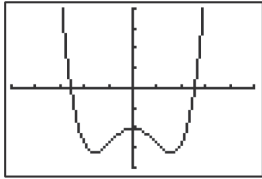

b.

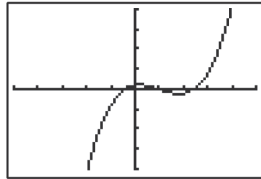

c.

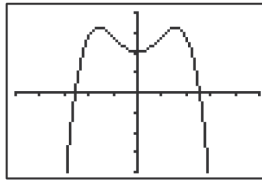

d.

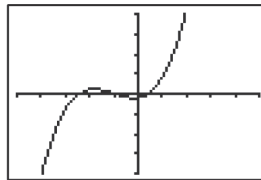

Graph each polynomial function.

13. $f(x) = x(x-3)(x+2)(x-2)$

13. _____

a.

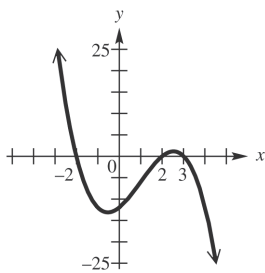

b.

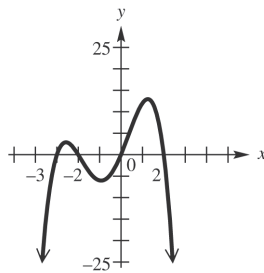

c.

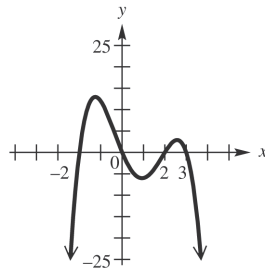

d.

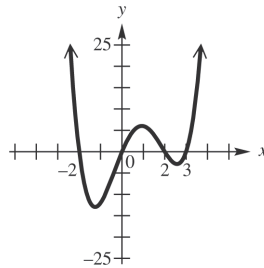

CHAPTER 3, FORM F

14. Factor $f(x) = 2x^3 - 3x^2 - 5x + 6$ given that 1 is a zero of $f(x)$.

- a. $f(x) = (x-1)(x+1)(3x-2)$
- b. $f(x) = (x+1)(x+2)(2x+3)$
- c. $f(x) = (x-1)(x-2)(2x+3)$
- d. $f(x) = (x-1)(x+2)(x-2)$

14. _____

15. Use a graphing calculator to find a real zero that is approximate to the nearest tenth for this polynomial.

$$f(x) = 3x^4 + 3x^3 - x^2 - 4x - 4$$

- a. -1.2
- b. -.7
- c. .2
- d. No real zeros

15. _____

16. Find a cubic polynomial having the graph shown.

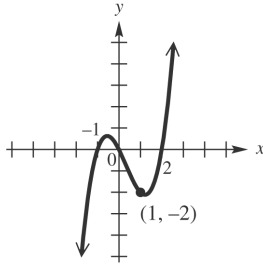

- a. $f(x) = \frac{1}{2}x^3 - \frac{1}{2}x^2 - x$
- b. $f(x) = -x^3 + x^2 + 2x$
- c. $f(x) = x^3 - x^2 - 2x$
- d. $f(x) = -\frac{1}{2}x^3 + \frac{1}{2}x^2 + x$

16. _____

CHAPTER 3, FORM F

17. Which one of the functions defined below has a graph with no y -intercept?

- a. $f(x) = \frac{x^2 - 3}{x^2}$ b. $f(x) = \frac{x + 3}{x - 2}$
 c. $f(x) = \frac{x^2}{x^2 - 3}$ d. $f(x) = \frac{2}{x - 3}$

17. _____

Graph each rational function.

18. $f(x) = \frac{-3}{x + 2}$

18. _____

a.

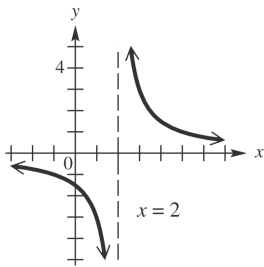

b.

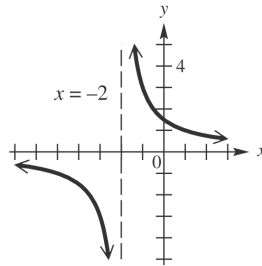

c.

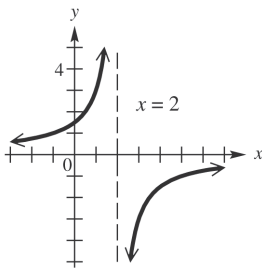

d.

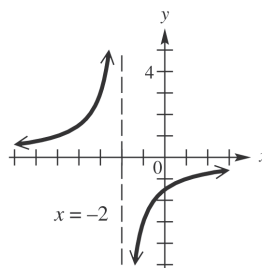

CHAPTER 3, FORM F

19. $f(x) = \frac{-4}{x^2 - 4}$

a.

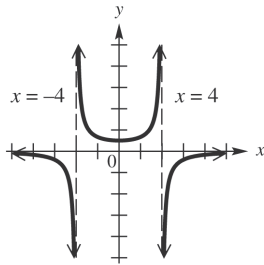

b.

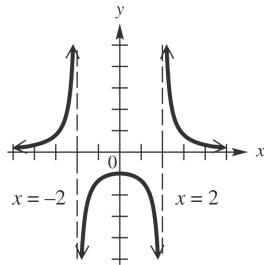

c.

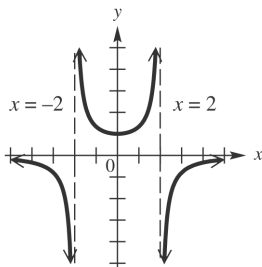

d.

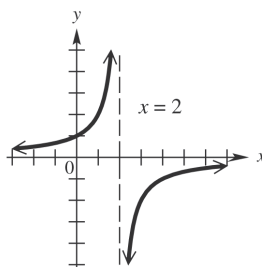

19. _____

20. For the rational function defined by $f(x) = \frac{2x^2 + 3x - 5}{x}$,

determine the equation of the oblique asymptote.

- a. $y = 2x - 3$ b. $y = 2x + 3$
 c. $y = 3x + 4$ d. $y = 3x + 5$

20. _____

21. The time it takes to complete a certain job varies inversely to the number of people working on that job. If it takes 32 hours for 7 carpenters to frame a house, then how long will it take 56 carpenters to do the job?

- a. 4 hours b. 12.3 hours
 c. 40 hours d. 56 hours

21. _____

22. For a fixed interest rate, interest varies jointly as the principal and the time in years. If a principal of \$5000 invested for 4 yr earns \$900, how much will \$6000 invested for 3 yr earn at the same interest rate?

- a. \$180 b. \$810
 c. \$900 d. \$1800

22. _____

CHAPTER 4, FORM A
COLLEGE ALGEBRA AND TRIGONOMETRY

NAME _____
 DATE _____

1. Consider the function defined by $f(x) = \sqrt{x+9}$.

a. What are the domain and range of f ?

1a. _____

b. Write an equation for $f^{-1}(x)$.

1b. _____

c. What are the domain and the range of f^{-1} ?

1c. _____

2. Match the equation with its correct graph: $y = 4^{-x}$

2. _____

(a)

(b)

(c)

(d)

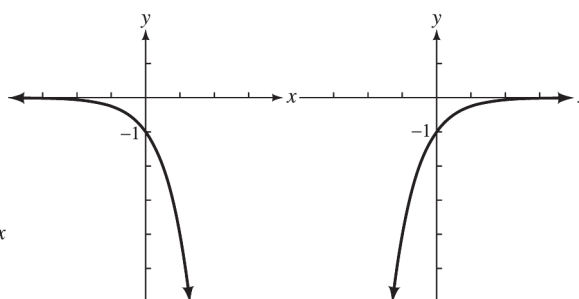
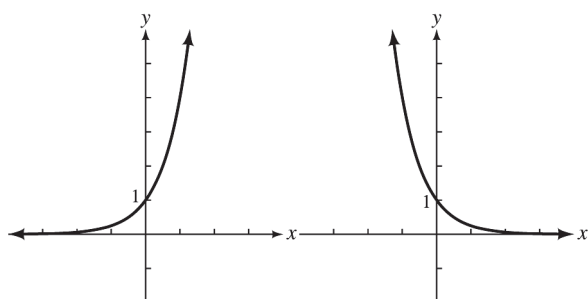

Graph the function.

3. $f(x) = \left(\frac{1}{3}\right)^x$

3.

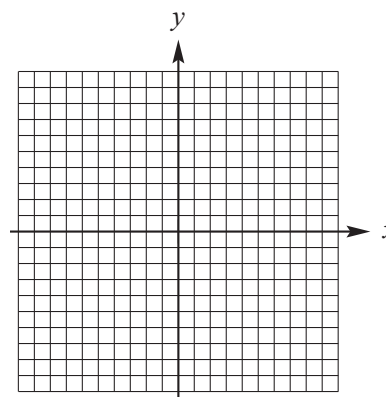

4. Solve $25^{x-3} = 125^{x+1}$.

4. _____

5a. Write $6^3 = 216$ in logarithmic form.

5a. _____

5b. Write $\log_4 1024 = 5$ in exponential form.

5b. _____

CHAPTER 4, FORM A

6. Use properties of logarithms to write the following as a sum, difference, or product of logarithms.

$$\ln \sqrt[4]{\frac{x^7}{y^5 z}}$$

6. _____

Use a calculator to find approximations for each of the following logarithms. Express answers to three decimal places.

7. $\ln 650$

7. _____

8. $\ln q = 3.5$

8. _____

9. $\log_{\sqrt{2}} \sqrt{5}$

9. _____

10. If $f(x) = a^x$ and $f(3) = 125$, find the following values of $f(x)$.

a. $f(0)$

10. a. _____

b. $f(-2)$

b. _____

11. What values of x cannot possibly be solutions of the following equation?

$$\log_a(3x+1) = 2$$

11. _____

Use properties of logarithms to solve each equation. Express answers to three decimal places.

12. $\log \sqrt{x} = \log(x - 6)$

12. _____

13. $\log_2(x + 7) + \log_2 x - 3$

13. _____

14. $2 \log_2 x = 3 + \log_2(x - 2)$

14. _____

15. $\ln(2x + 5) - \ln 3 = \ln(x - 1)$

15. _____

16. Between what two consecutive integers must x be if $4^x = 32$? Explain why this is so.

16. _____

17. The temperature of a liquid t minutes after being placed into an environment having constant temperature T_0 is given by $T(t) = T_0 + 100e^{-15t}$. How long, to the nearest minute, will it take a cup of hot tea to cool to a temperature of 20°C in a room at 15°C ?

17. _____

18. If \$1,500 is invested at a rate of 2.5% per year compounded quarterly, what is the principal after one year?

18. _____

CHAPTER 4, FORM A

19. A radioactive substance is decaying so that the number of grams present after t days is given by the function $A(t) = 2000e^{-0.015t}$

a. Find the amount of the substance, to the nearest tenth of a gram, present after 60 days.

b. Find the half-life of the substance.

19. a. _____

b. _____

20. The population of a town is 1250 and increasing at a rate of 1.3% per year, while the number of cats in the town is currently 200 and increasing at a rate of 9% per year. Assuming this trend continues, estimate graphically when the cat population will exceed the human population in this town.

20. _____

CHAPTER 4, FORM B
COLLEGE ALGEBRA AND TRIGONOMETRY

NAME _____
 DATE _____

1. Consider the function defined by $f(x) = \sqrt{4-x}$.

a. What are the domain and range of f ?

1a. _____

b. Find the rule for $f^{-1}(x)$.

1b. _____

c. What are the domain and the range of f^{-1} ?

1c. _____

2. Match the equation with its correct graph: $y = -4^{-x}$

2. _____

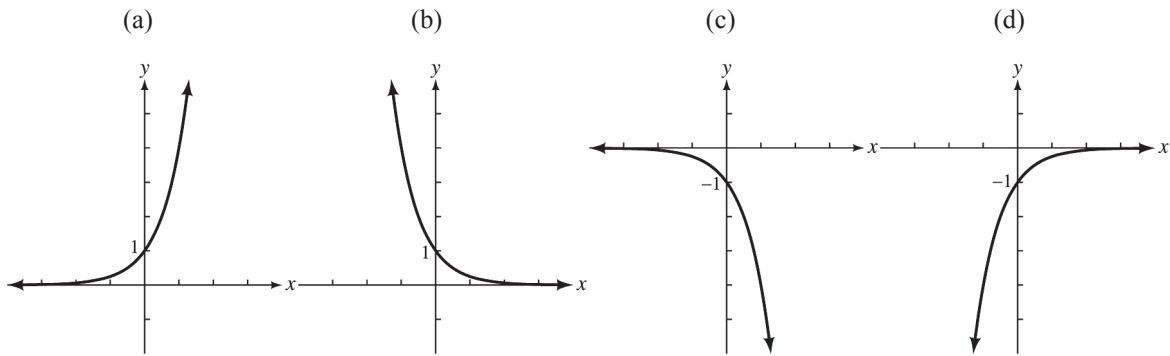

Graph the function.

3. $y = \left(\frac{1}{2}\right)^{-x+1}$

3.

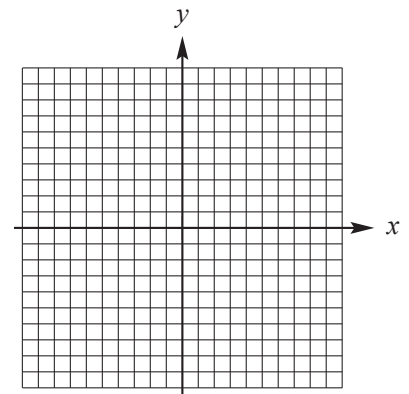

4. Solve $3^{x+3} = 27^{2x}$.

4. _____

5a. Write $3^{4.1} = a$ in logarithmic form.

5a. _____

5b. Write $\log_8 \frac{1}{2} = b$ in exponential form.

5b. _____

CHAPTER 4, FORM B

6. Use properties of logarithms to write the following as a sum, difference, or product of logarithms.

$$\log_3 \frac{y^2 \sqrt{z}}{x}$$

6. _____

Use a calculator to find approximations for each of the following logarithms. Express answers to three decimal places.

7. $\ln 248$

7. _____

8. $\ln q = 3.5$

8. _____

9. $\log_2 7$

9. _____

10. If $f(x) = a^x$ and $f(4) = 81$, find the following values of $f(x)$.

a. $f(5)$

10. a. _____

b. $f(-1)$

b. _____

11. What values of x cannot possibly be solutions of the following equation?
 $\log_a(4x - 1) = -2$

11. _____

Use properties of logarithms to solve each equation. Express answers to three decimal places.

12. $\log_4(r - 8) = 3$

12. _____

13. $2 \log_3 x = 3 \log_3 5$

13. _____

14. $\log_a 25 = \frac{1}{2}$

14. _____

15. $\log_4(x + 4) - \log_4(x - 4) = \log_4 3$

15. _____

16. Between what two consecutive integers must x be if $6^x = 37$? Explain why this is so.

16. _____

17. The number of bacteria in a certain culture is given by the function
 $B(t) = 300,000e^{0.5t}$,
 where t is the time in hours after the beginning of the experiment.

a. How many bacteria will be present after 48 hr?

17. a. _____

b. How long, to the nearest tenth of an hour, will it take the number of bacteria in the culture to double?

b. _____

CHAPTER 4, FORM B

- 18.** The temperature of a liquid t minutes after being placed into an environment having constant temperature T_0 is given by $T(t) = T_0 + 100e^{-2t}$.
How long, to the nearest minute, will it take a bowl of hot soup to cool to a temperature of 27°C in a room at 20°C ? **18.** _____
- 19.** How many years, to the nearest tenth, will be needed for \$2050 to increase to \$3000 at 2.2% compounded monthly? **19.** _____
- 20.** The population of a town is 2300 and increasing at a rate of 1.2% per year, while the number of dogs in the town is currently 625 and increasing at a rate of 9% per year. Assuming this trend continues, estimate graphically when the dog population will exceed the human population in this town. **20.** _____

CHAPTER 4, FORM C
COLLEGE ALGEBRA AND TRIGONOMETRY

NAME _____
 DATE _____

1. Consider the function defined by $f(x) = \sqrt{x-4}$.

a. What are the domain and range of f ?

1a. _____

b. Find the rule for $f^{-1}(x)$.

1b. _____

c. What are the domain and the range of f^{-1} ?

1c. _____

2. Match the equation with its correct graph: $y = \log_2 x$ 2. _____

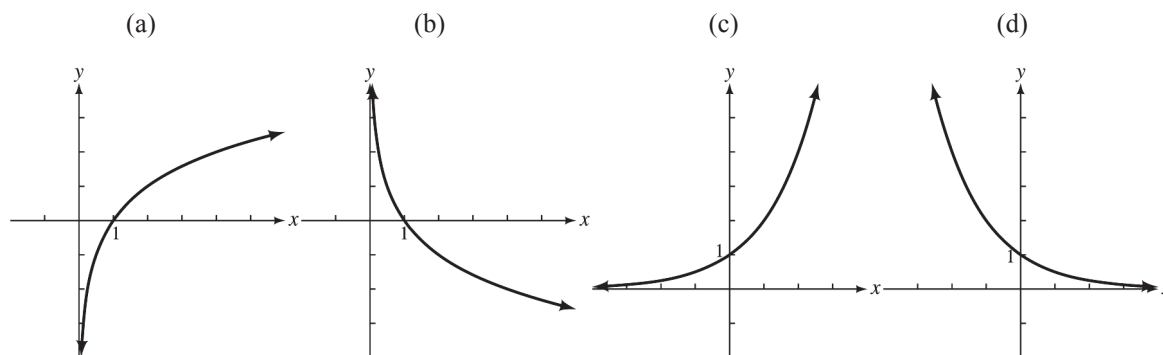

Graph the function.

3. $y = \left(\frac{1}{2}\right)^x - 1$

3.

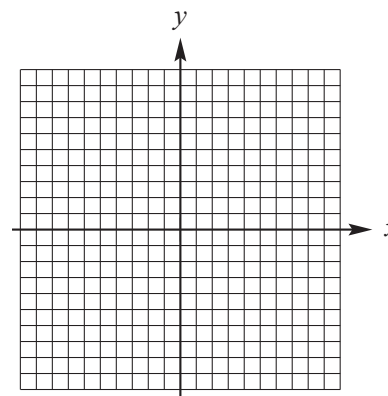

4. Solve $8^{x+6} = 64^{2x-1}$.

4. _____

5a. Write $5^{-2} = 0.04$ in logarithmic form.

5a. _____

5b. Write $\log x = 5y$ in exponential form.

5b. _____

CHAPTER 4, FORM C

6. Use properties of logarithms to write the following as a sum, difference, or product of logarithms. 6. _____

$$\log_3 \frac{xz}{y}$$

Use a calculator to find approximations for each of the following logarithms. Express answers to three decimal places.

7. $\ln 35.15$ 7. _____
8. $\ln y = -0.28$ 8. _____
9. $\log_{1.5} 78.3$ 9. _____
10. If $f(x) = a^x$ and $f(6) = 64$, find the following values of $f(x)$. 10. a. _____
- a. $f(4)$ b. _____
- b. $f(-3)$ 11. _____
11. What values of x cannot possibly be solutions of the following equation? 11. _____
- $\log_a(3x - 5) = 4$

Use properties of logarithms to solve each equation. Express answers to three decimal places.

12. $\ln(-4 - x) + \ln 3 = \ln(2 - x)$ 12. _____
13. $\log_6(x + 5) + \log_6 x = 2$ 13. _____
14. $\ln x - 3 \ln 2 = \ln \frac{9}{x}$ 14. _____
15. $\log x - \log 5 = \log 2 - \log(x - 3)$ 15. _____
16. Between what two consecutive integers must x be if $3^x = 28$? Explain why this is so. 16. _____
17. The amount of a radioactive substance present after t seconds is given by the function $A(t) = 4000e^{-0.3t}$, 17. a. _____
- a. How many grams of the substance, to the nearest tenth of a gram, will be present after 21 sec? b. _____
- b. Find the half-life of the substance to the nearest tenth of a second.
18. The temperature of a liquid t minutes after being placed into an environment having constant temperature T_0 is given by $T(t) = T_0 + 100e^{-1t}$. 18. _____
- How long, to the nearest minute, will it take a cup of hot coffee to cool to a temperature of 20°C in a refrigerator at 5°C ?

CHAPTER 4, FORM C

19. How many years, to the nearest tenth, will be needed for \$4000 to increase to \$9000 at 1.8% compounded monthly?

19. _____

20. The population of a town is 1750 and increasing at a rate of 1.5% per year, while the number of cats in the town is currently 625 and increasing at a rate of 9% per year. Assuming this trend continues, estimate graphically when the cat population will exceed the human population in this town.

20. _____

CHAPTER 4, FORM D
COLLEGE ALGEBRA AND TRIGONOMETRY

NAME _____
 DATE _____

1. Consider the function defined by $f(x) = \sqrt[3]{2x-1}$.

a. What are the domain and range of f ?

1a. _____

b. Find the rule for $f^{-1}(x)$.

1b. _____

c. What are the domain and the range of f^{-1} ?

1c. _____

2. Match the equation with its correct graph: $y = 2^{-x}$

2. _____

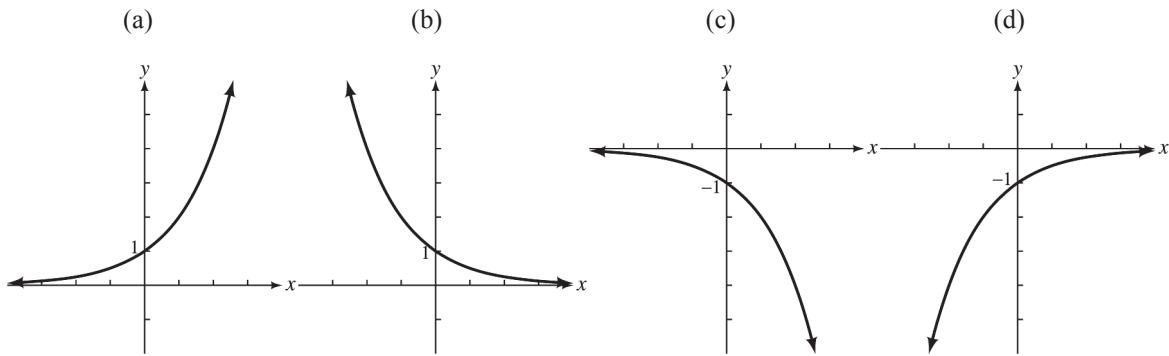

Graph the function.

3. $y = 3^{-x} + 1$

3.

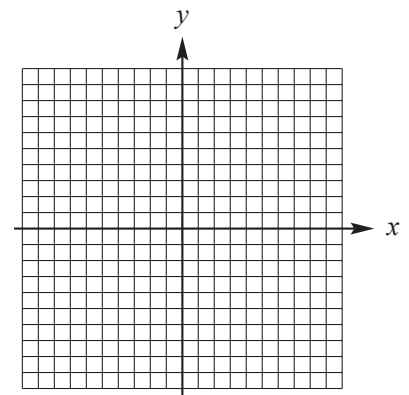

4. Solve $3^{2x-1} = 27^{2x}$.

4. _____

5a. Write $7^{1/2} = \sqrt{7}$ in logarithmic form.

5a. _____

5b. Write $\log_{49} \sqrt[3]{7} = \frac{1}{6}$ in exponential form.

5b. _____

CHAPTER 4, FORM D

6. Use properties of logarithms to write the following as a sum, difference, or product of logarithms.

$$\log_2 \frac{\sqrt{xz}}{\sqrt[3]{y^2}}$$

6. _____

Use a calculator to find approximations for each of the following logarithms. Express answers to three decimal places.

7. $\ln 897$

7. _____

8. $\ln a = -2.9$

8. _____

9. $\log_{1.9} 25.6$

9. _____

10. If $f(x) = a^x$ and $f(3) = 1000$, find the following values of $f(x)$.

a. $f(2)$

10. a. _____

b. $f(0)$

b. _____

11. What values of x cannot possibly be solutions of the following equation?

11. _____

$$\log_a(2x - 3) = -2$$

Use properties of logarithms to solve each equation. Express answers to three decimal places.

12. $2 \log x = \log(6 - x)$

12. _____

13. $\log_9 x + \log_9(x - 8) = 1$

13. _____

14. $\log_3(4m + 5) = 4$

14. _____

15. $\log_3 6 - \log_3(2x + 3) = \log_3(x + 1)$

15. _____

16. Between what two consecutive integers must x be if $5^x = 50$? Explain why this is so.

16. _____

17. The population of Twin Lakes is given by the function

$$P(x) = 3250e^{0.2x},$$

where x is the number of years after 1970.

- a. What will the population be in the year 2015?

17. a. _____

- b. In what year will the population of Twin Lakes be double the population of 1970?

b. _____

18. The temperature of a liquid t minutes after being placed into an environment having constant temperature T_0 is given by $T(t) = T_0 + 100e^{-.12t}$. How long, to the nearest minute, will it take a mug of hot chocolate to cool to a temperature of 25°C in a room at 15°C ?

18. _____

CHAPTER 4, FORM D

19. How many years, to the nearest tenth, will be needed for \$5000 to increase to \$8,000 at 3% compounded monthly?

19. _____

20. The population of a town is 1900 and increasing at a rate of 1.4% per year, while the number of dogs in the town is currently 650 and increasing at a rate of 8% per year. Assuming this trend continues, estimate graphically when the dog population will exceed the human population in this town.

20. _____

CHAPTER 4, FORM E
COLLEGE ALGEBRA AND TRIGONOMETRY

NAME _____
DATE _____

1. Consider the function defined by $f(x) = \sqrt{x-5}$. Which of the following represents the domain and the range of $f(x)$? **1.** _____

- a. $(-\infty, \infty); (-\infty, \infty)$ b. $[0, \infty); [5, \infty)$
c. $(-\infty, 5]; [0, \infty)$ d. $(-\infty, 5]; (0, \infty)$

2. If $f(x) = \sqrt{x+5}$, find $f^{-1}(x)$. **2.** _____

- a. $x^2 - 5$ b. $\sqrt{x^2 + 5}$
c. $x^2 + 5$ d. $5 - x^2$

3. Solve $4^{(9-3x)} = 64$. **3.** _____

- a. $\{-2\}$ b. $\{1\}$ c. $\{2\}$ d. $\{3\}$

Write in logarithmic form.

4. $3^{-2} = \frac{1}{9}$ **4.** _____

- a. $\log_{-2} 3 = \frac{1}{9}$ b. $\log_{-2} \frac{1}{9} = 3$
c. $\log_3 \frac{1}{9} = -2$ d. $\log_3 -2 = \frac{1}{9}$

Write in exponential form.

5. $\log_5 \frac{1}{25} = -2$ **5.** _____

- a. $5^{1/25} = -2$ b. $\left(\frac{1}{25}\right)^{-2} = 5$
c. $5^{-2} = \frac{1}{25}$ d. $-2^5 = \frac{1}{25}$

CHAPTER 4, FORM E

Graph each function.

6. $y = \left(\frac{1}{2}\right)^x + 1$

6. _____

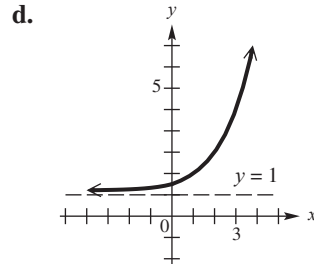
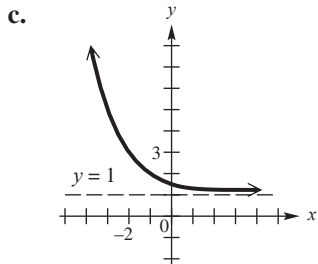
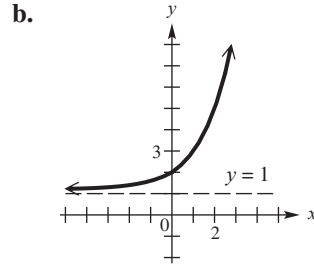
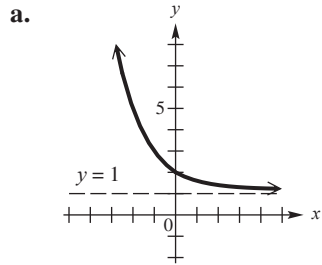

7. $y = \log_{1/3}(x-2)$

7. _____

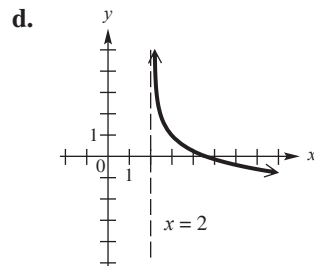
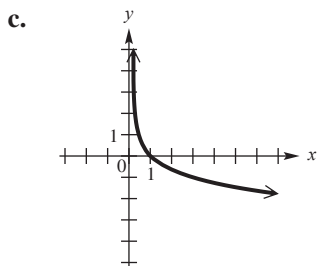
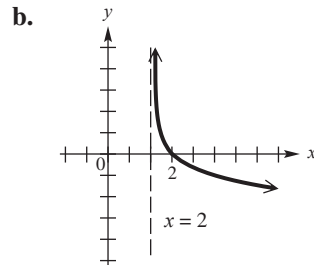
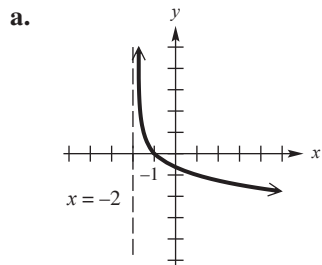

CHAPTER 4, FORM E

8. Use properties of logarithms to write the following as a sum, difference, or product of logarithms. 8. _____

$$\log_8 \frac{w^2 \sqrt{x}}{y}$$

- a. $\frac{2 \log_8 w + \frac{1}{2} \log_8 y}{\log_8 y}$ b. $2 \log_8 w + \frac{1}{2} \log_8 x - \log_8 y$
 c. $2 \log_8 w \left(\frac{1}{2} \log_8 x \right) - \log_8 y$ d. $2 \log_8 w^2 + \frac{1}{2} \log_8 \sqrt{x} - \log_8 y$

Use a calculator to find approximations for each of the following logarithms. Express answers to three decimal places.

9. $\log_{13} 10$ 9. _____
 a. 6.195 b. 1.255 c. 0.898 d. 1.477

10. $\ln 131$ 10. _____
 a. 0.131 b. 1.892 c. 4.875 d. 6.127

11. If $f(x) = a^x$ and $f(3) = 64$, find $f(-2)$. 11. _____
 a. -16 b. $\frac{1}{4}$ c. $\frac{1}{16}$ d. $-\frac{1}{16}$

12. What values of x cannot possibly be solutions of the following equation? 12. _____
 $\log_a(2x + 5) = -1$
 a. $\left(-\infty, -\frac{5}{2}\right)$ b. $\left(-\infty, -\frac{5}{2}\right]$ c. $\left[-\frac{5}{2}, \infty\right)$ d. $\left[-\frac{5}{2}, \infty\right)$

13. Between what two consecutive integers must x be if $2^x = 15$? 13. _____
 a. 2 and 3 b. 3 and 4
 c. 4 and 5 d. 5 and 6

Use properties of logarithms to solve each equation. Express answers to three decimal places.

14. $\log(x + 9) = 1 - \log x$ 14. _____
 a. $\left\{\frac{1}{2}\right\}$ b. $\{1, -1\}$ c. $\{-1\}$ d. $\{1\}$

15. $5^{x-2} = 15$ 15. _____
 a. $\{-0.317\}$ b. $\{3.099\}$ c. $\{3.683\}$ d. $\{4.807\}$

16. $\log_9(x - 7) + \log_9(x - 7) = 1$ 16. _____
 a. $\{-10, 10\}$ b. $\{\sqrt{50}\}$ c. $\{-\sqrt{50}\}$ d. $\{10\}$

CHAPTER 4, FORM F
COLLEGE ALGEBRA AND TRIGONOMETRY

NAME _____
 DATE _____

1. Consider the function defined by $f(x) = x^2 - 3; x \geq 0$. Which of the following represents the domain and the range of $f(x)$?

- a. $(-\infty, \infty); (-\infty, \infty)$ b. $(-\infty, -3]; (-\infty, \infty)$
 c. $[-3, \infty); [0, \infty)$ d. $(-\infty, -3]; (-3, 0]$

1. _____

2. If $f(x) = \sqrt{4-x}$, find $f^{-1}(x)$.

- a. $x^2 + 4$ b. $\sqrt{x^2 + 4}$
 c. $x^2 - 4$ d. $4 - x^2$

2. _____

3. Solve $2^{5-3x} = \frac{1}{16}$.

- a. $\{-3\}$ b. $\{3\}$ c. $\left\{\frac{1}{3}\right\}$ d. $\left\{-\frac{1}{3}\right\}$

3. _____

Write in logarithmic form.

4. $32^{2/5} = 4$

- a. $\log_{32} 4 = \frac{2}{5}$ b. $\log_{2/5} 32 = 4$
 c. $\log_{32} \frac{2}{5} = 4$ d. $\log_4 32 = \frac{2}{5}$

4. _____

Write in exponential form.

5. $\log_x y = z$

- a. $x^y = z$ b. $x^z = y$
 c. $z^x = y$ d. $y^z = x$

5. _____

CHAPTER 4, FORM F

6. $y = \left(\frac{1}{3}\right)^{x+1}$

6. _____

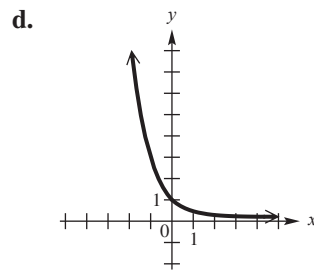
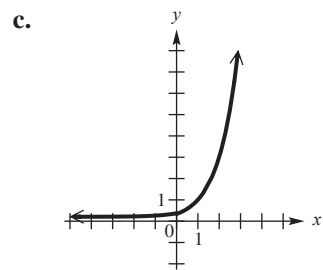
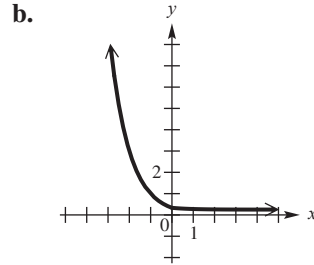
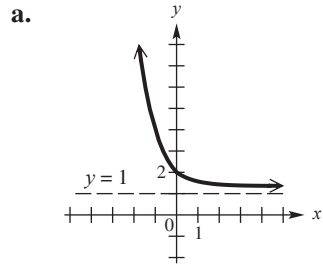

7. $y = \log_2(x-1)$

7. _____

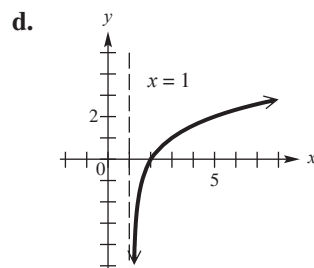
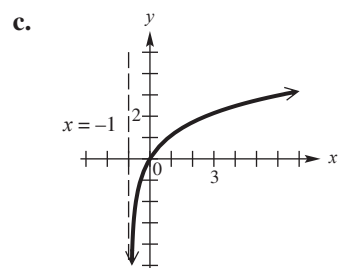
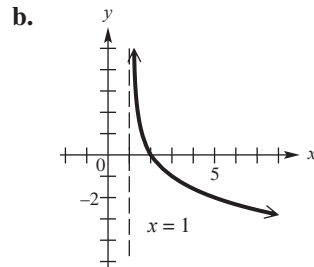
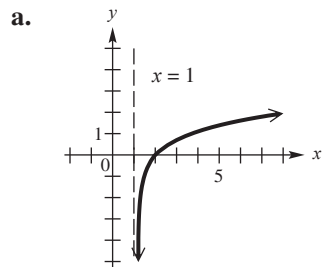

CHAPTER 4, FORM F

8. Use properties of logarithms to write the following as a sum, difference, or product of logarithms. 8. _____

$$\log_7 \frac{x^3 z}{\sqrt{y}}$$

- a. $\frac{(3\log_7 x)(\log_7 z)}{\frac{1}{2}\log_7 y}$ b. $(3\log_7 x)(\log_7 z) - \frac{1}{2}\log_7 y$
 c. $3\log_7 x + \log_7 z - \frac{1}{2}\log_7 y$ d. $(3\log_7 x)(\log_7 z) \left(\frac{1}{2}\log_7 y\right)$

Use a calculator to find approximations for each of the following logarithms. Express answers to three decimal places.

9. $\log_3 40$ 9. _____
 a. .298 b. 3.358 c. 1.602 d. 2.139

10. $\ln 14$ 10. _____
 a. 2.639 b. 2.894 c. 4.321 d. 5.135

11. If $f(x) = a^x$ and $f(4) = 625$, find $f(-3)$. 11. _____
 a. -125 b. $\frac{1}{25}$ c. $-\frac{1}{125}$ d. $\frac{1}{125}$

12. What values of x cannot possibly be solutions of the following equation? 12. _____
 $\log_a(4x - 2) = 5$
 a. $\left[\frac{1}{2}, \infty\right)$ b. $\left(\frac{1}{2}, \infty\right)$ c. $\left(-\infty, \frac{1}{2}\right]$ d. $\left(-\infty, \frac{1}{2}\right)$

13. Between what two consecutive integers must x be if 13. _____
 $5^x = 620$?
 a. 2 and 3 b. 3 and 4
 c. 5 and 6 d. 7 and 8

Use properties of logarithms to solve each equation. Express answers to three decimal places.

14. $\log(2 + x) - \log(x - 2) = \log 5$ 14. _____
 a. $\{-3\}$ b. $\{0\}$ c. $\{3\}$ d. $\left\{\frac{5}{2}\right\}$

15. $5^{2w+1} = 36$ 15. _____
 a. $\{.478\}$ b. $\{.613\}$ c. $\{1.026\}$ d. $\{1.531\}$

CHAPTER 4, FORM F

16. $\log_3(13x + 2) - \log_3(x + 2) = 2$ 16. _____
a. {5} b. {4} c. {7} d. $\left\{ \frac{2}{11} \right\}$
17. The number of bacteria in a culture t hours after the beginning of the experiment is given by the function 17. _____
 $B(t) = 8,000e^{0.2t}$
How long, to the nearest tenth of an hour, would it take the bacteria in the experiment to double?
a. 4.3 hr b. 0.35 hr
c. 0.43 hr d. 3.5 hr
18. The temperature of a liquid t minutes after being placed into an environment having constant temperature T_0 is given by 18. _____
 $T(t) = T_0 + 100e^{-21t}$
How long, to the nearest minute, will it take a bowl of hot soup to cool to a temperature of 25°C in a room at 15°C ?
a. 11 min b. 7 min
c. 9 min d. 4 min
19. Find the number of years for \$2,800 to grow to \$4,100 at 19. _____
4.2% compounded semiannually.
a. 7.8 yr b. 9.2 yr
c. 11.1 yr d. 13.5 yr
20. The population of a town is 1825 and increasing at a rate of 20. _____
1.4% per year, while the number of dogs in the town is currently 820 and increasing at a rate of 8% per year. Assuming this trend continues, estimate graphically when the dog population will exceed the human population in this town.
a. 66.3 yr b. 12.7 yr
c. 80.4 yr d. 14.1 yr

CHAPTER 5, FORM A
COLLEGE ALGEBRA AND TRIGONOMETRY

NAME _____
 DATE _____

1. Find the complement of an angle measuring 8° . 1. _____
2. Calculate $92^\circ 29' + 18^\circ 52'$. 2. _____
3. Convert 59.18° to degrees, minutes, and seconds. 3. _____
4. Find the angle of smallest possible positive measure coterminal with -197° . 4. _____
5. A propeller rotates 300 times a minute. Through how many degrees does a point on the edge of the propeller rotate in 1 second? 5. _____
6. Find the values of the indicated trigonometric functions for the angle θ in standard position having the point $(-4, 3)$ on its terminal side. 6. $\sin \theta$: _____
 $\cos \theta$: _____
 $\tan \theta$: _____
7. If θ is a quadrantal angle, then what are the possible values of $\tan \theta$? 7. _____
8. If $\tan \theta > 0$ and $\sin \theta < 0$, in what quadrant does the terminal side of θ lie? 8. _____
9. Is the statement $\csc \theta = .459$ possible for some angle θ ? 9. _____
10. Find $\tan \alpha$ and $\sec \alpha$, given the following:
 $\sin \alpha = \frac{3}{5}$ and $\cos \alpha < 0$. 10. $\tan \alpha$: _____
 $\sec \alpha$: _____
11. Find the reference angle for an angle of 282° . 11. _____
12. Give the exact value of $\cot 120^\circ$. Rationalize the denominator if necessary. 12. _____
13. Use a calculator to find $\cos 12.8317^\circ$. Round your answer to six decimal places. 13. _____
14. Find the value of s in the interval $[0, 90^\circ]$ such that $\sin s = 0.65137$. Round your answer to five decimal places. 14. _____
15. Exactly determine the angle between 0° and 360° such that $\sec \alpha = \sqrt{2}$ and $\sin \alpha < 0$. 15. _____
16. In right triangle $\triangle ABC$, C is the right angle. If $\sin A = 0.37$, find $\cos B$. 16. _____

CHAPTER 5, FORM A, PAGE 2

17. Find the exact values of each part labeled with a letter.

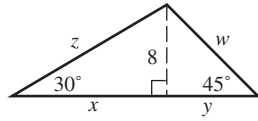

17. _____

18. Solve the triangle.

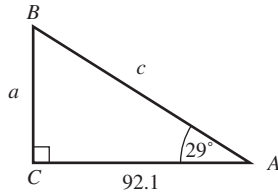

18. _____

19. A boat leaves a dock on a bearing of N 25° W and travels for 24 km. The boat then turns and travels another 10 km on a bearing of S 65° W. How far is the boat from the dock?
20. A forest ranger is at a spot which has an angle of elevation of 16.5° to the top of a 215-foot-tall tower. How far is the ranger from the base of the tower? Round the answer to the nearest whole foot.

19. _____

20. _____

CHAPTER 5, FORM B
COLLEGE ALGEBRA AND TRIGONOMETRY

NAME _____
 DATE _____

- | | |
|--|--|
| 1. Find the complement of an angle measuring 60° . | 1. _____ |
| 2. Calculate $180^\circ - 50^\circ 39' 27''$. | 2. _____ |
| 3. Convert 31.43° to degrees, minutes, and seconds. | 3. _____ |
| 4. Find the angle of smallest possible positive measure coterminal with -98° . | 4. _____ |
| 5. A bicycle tire rotates 200 times per minute. Through how many degrees does a point on the edge of the tire move in 1 second? | 5. _____ |
| 6. Find the values of the indicated trigonometric functions for the angle θ in standard position having the point $(6, -8)$ on its terminal side. | 6. $\sin \theta$: _____
$\cos \theta$: _____
$\tan \theta$: _____ |
| 7. If θ is a quadrantal angle, then what are the possible values of $\sin \theta$? | 7. _____ |
| 8. If $\cos \theta > 0$ and $\cot \theta > 0$, in what quadrant does the terminal side of θ lie? | 8. _____ |
| 9. Is the statement $\tan \theta = -7.249$ possible for some angle θ ? | 9. _____ |
| 10. Find the exact values of $\sin \alpha$ and $\cos \alpha$, given the following:
$\tan \alpha = \frac{2}{5}$ and $\sec \alpha < 0$. | 10. $\sin \alpha$: _____
$\cos \alpha$: _____ |
| 11. Find the reference angle for an angle of -125° . | 11. _____ |
| 12. Evaluate $\tan 300^\circ$. Give the exact value and rationalize denominator if applicable. | 12. _____ |
| 13. Use a calculator to find $\sin 63.175^\circ$. Round your answer to six decimal places. | 13. _____ |
| 14. Find the value of s in the interval $[0, 90^\circ]$ such that $\sin s = 0.1365$. Round your answer to five decimal places. | 14. _____ |
| 15. Exactly determine the angle between 0° and 360° such that $\cos \alpha = -1$. | 15. _____ |
| 16. In right triangle $\triangle ABC$, C is the right angle. If $\tan A = 1.5$, find $\tan B$. | 16. _____ |

CHAPTER 5, FORM B, PAGE 2

17. Find $\csc A$, $\sec A$, and $\cot A$ for the figure below.

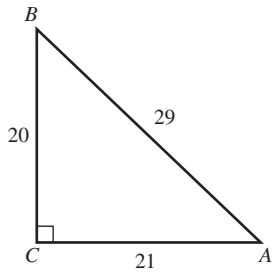

17. $\csc A$: _____

$\sec A$: _____

$\cot A$: _____

18. Solve the triangle.

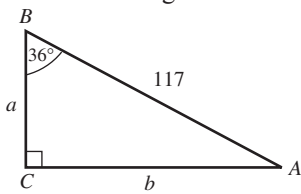

18. _____

19. Two ships leave a port at the same time, the first on a bearing of 65° , the second on a bearing of 155° . After one hour the first boat has traveled 20 nautical miles while the second had traveled 25 nautical miles. To the nearest nautical mile, how far apart are the two ships?
20. From the top of a 150-foot-tall lighthouse, a boat is spotted with an angle of depression of 18.4° . How far is the boat from the base of the lighthouse? Round the answer to the nearest whole foot.

19. _____

20. _____

CHAPTER 5, FORM C
COLLEGE ALGEBRA AND TRIGONOMETRY

NAME _____
 DATE _____

1. Find the supplement of an angle measuring 18° . 1. _____
2. Calculate $47^\circ 23' - 73^\circ 48'$. 2. _____
3. Convert $34^\circ 51' 35''$ to decimal degrees. Round your answer to the nearest hundredth of a degree. 3. _____
4. Find the angle of smallest possible positive measure coterminal with 735° . 4. _____
5. A pulley is rotating 450 times per minute. Through how many degrees will a point on the edge of the pulley move in $\frac{2}{3}$ second? 5. _____
6. Find the values of the indicated trigonometric functions for the angle θ in standard position having the point $(-2, 4)$ on its terminal side. 6. $\sin \theta$: _____
 $\cos \theta$: _____
 $\tan \theta$: _____
7. If θ is a quadrantal angle, then what are the possible values of $\cos \theta$? 7. _____
8. If $\sin \theta > 0$ and $\sec \theta < 0$, will $\tan \theta$ be positive or negative? 8. _____
9. Is the statement $\sec \theta = -.45$ possible for some angle θ ? 9. _____
10. Find $\sin \alpha$ and $\cos \alpha$, given the following:
 $\tan \alpha = \frac{7}{3}$ and $\sec \alpha < 0$. Rationalize denominators when applicable. 10. $\sin \alpha$: _____
 $\cos \alpha$: _____
11. Find the reference angle for an angle of 197° . 11. _____
12. Evaluate $\cos 60^\circ$. Give exact value and rationalize denominator as necessary. 12. _____
13. Use a calculator to find $\sec 3.571^\circ$. Round your answer to six decimal places. 13. _____
14. Find the value of s in the interval $[0, 90^\circ]$ such that $\cos s = 0.33119$. Round your answer to five decimal places. 14. _____
15. Exactly determine the angle between 0° and 360° such that $\tan \alpha = \sqrt{3}$ and $\cos \alpha > 0$. 15. _____

CHAPTER 5, FORM C, PAGE 2

16. In right triangle $\triangle ABC$, C is the right angle. If $\cos A = 0.63$, find $\sin B$.

16. _____

17. Find $\sin A$, $\cos A$, and $\tan A$ for the figure below.

17. $\sin A$: _____

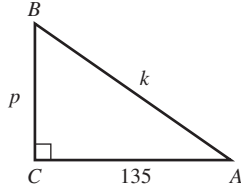

$\cos A$: _____

$\tan A$: _____

18. Solve the triangle.

18. _____

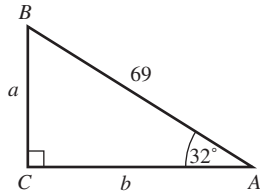

19. An observer is located at the origin of a coordinate system. Find the bearing of an object located at the point $(-5, 0)$.

19. _____

20. A laser gun is located 3000 ft from the base of a wall. The beam makes an angle of $1/2^\circ$ with the horizon. How far up will the laser ray hit the wall? Round answer to the nearest whole foot.

20. _____

CHAPTER 5, FORM D, PAGE 2

17. Find $\csc A$, $\sec A$, and $\cot A$ for the figure below.

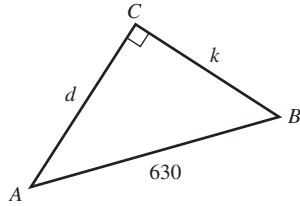

17. $\csc A$: _____

$\sec A$: _____

$\cot A$: _____

18. Solve the triangle.

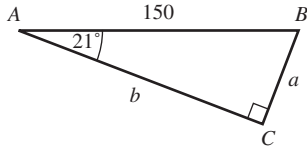

18. _____

19. A boat leaves a dock on a bearing of $S 38^\circ E$ and travels for 5 miles. The boat then turns and travels another 6 miles on a bearing of $N 52^\circ E$. How far is the boat from the dock? Round your answer to the nearest tenth of a mile.

19. _____

20. An observer is located at the origin of a coordinate system. Find the bearing of an object located at the point $(-3, 3)$.

20. _____

CHAPTER 5, FORM E
COLLEGE ALGEBRA AND TRIGONOMETRY

NAME _____
 DATE _____

1. Find the complement of an angle measuring 12° . 1. _____
 - a. 60°
 - b. 78°
 - c. 90°
 - d. 168°

2. Calculate $14^\circ 19' 41'' + 27^\circ 22' 38''$. 2. _____
 - a. $77^\circ 8' 6''$
 - b. $41^\circ 42' 19''$
 - c. $76^\circ 39' 6''$
 - d. $76^\circ 39' 46''$

3. Convert 70.12° to degrees, minutes, and seconds. 3. _____
 - a. $70^\circ 07' 12''$
 - b. $70^\circ 06' 50''$
 - c. $70^\circ 12' 07''$
 - d. $70^\circ 12' 36''$

4. Find the angle of smallest possible positive measure coterminal with -140° . 4. _____
 - a. 40°
 - b. 220°
 - c. 80°
 - d. 260°

5. A top is rotating 420 times per minute. Through how many degrees will a point on the edge of the top move in $\frac{1}{2}$ second? 5. _____
 - a. 2520°
 - b. 1260°
 - c. $10\pi^\circ$
 - d. $210\pi^\circ$

6. Find the values of $\sin \theta$, $\cos \theta$, and $\tan \theta$ for the angle θ in standard position having $(-4, -3)$ on its terminal side. 6. _____
 - a. $\sin \theta = -\frac{3}{5}, \cos \theta = -\frac{4}{5}, \tan \theta = \frac{3}{4}$
 - b. $\sin \theta = \frac{4}{5}, \cos \theta = -\frac{3}{5}, \tan \theta = \frac{4}{3}$
 - c. $\sin \theta = -\frac{3}{5}, \cos \theta = \frac{4}{5}, \tan \theta = \frac{3}{4}$
 - d. $\sin \theta = \frac{4}{5}, \cos \theta = \frac{3}{5}, \tan \theta = -\frac{3}{4}$

7. List the possible values of $\cos \theta$ if θ is a quadrantal angle. 7. _____
 - a. $-1, -2, 1, 2$
 - b. 0
 - c. $-1, 0, 1$
 - d. $-1, 1$

8. If $\cot \theta > 0$ and $\sec \theta > 0$, what is the sign of the value of $\sin \theta$? 8. _____
 - a. positive
 - b. negative
 - c. zero
 - d. undefined

CHAPTER 5, FORM E, PAGE 2

9. Which statement is possible for some angle θ ? 9. _____
 a. $\tan \theta = 2.7$ b. $\sin \theta = 2.7$
 c. $\cos \theta = 2.7$ d. $(\cos \theta)(\sin \theta) = 2.7$
10. Find $\sin \alpha$ and $\cos \alpha$, given $\tan \alpha = \frac{3}{5}$ and $\sec \alpha < 0$. 10. _____
 a. $\sin \alpha = -\frac{3\sqrt{34}}{34}$, $\cos \alpha = -\frac{5\sqrt{34}}{34}$
 b. $\sin \alpha = \frac{3\sqrt{34}}{34}$, $\cos \alpha = \frac{5\sqrt{34}}{34}$
 c. $\sin \alpha = -\frac{3\sqrt{34}}{34}$, $\cos \alpha = \frac{5\sqrt{34}}{34}$
 d. $\sin \alpha = \frac{3\sqrt{34}}{34}$, $\cos \alpha = -\frac{5\sqrt{34}}{34}$
11. Find the reference angle for an angle of 218° . 11. _____
 a. 142° b. 38°
 c. 52° d. 128°
12. Evaluate $\sec 60^\circ$. 12. _____
 a. $\frac{1}{2}$ b. $-\frac{\sqrt{3}}{2}$
 c. 2 d. $\frac{\sqrt{3}}{2}$
13. Use a calculator to find $\sec 95.29^\circ$. Round your answer to three decimal places. 13. _____
 a. -10.846 b. -0.092
 c. 0.996 d. 1.004
14. Find the value of s in the interval $[0, 90^\circ]$ such that $\sin s = 0.25$. Round your answer to five decimal places. 14. _____
 a. 14.47751° b. 0.2568°
 c. 75.52249° d. 15°
15. Exactly determine the angle between 0° and 360° such that $\tan \alpha = 1$ and $\sin \alpha < 0$. 15. _____
 a. 0° b. 45°
 c. 315° d. 225°
16. In right triangle $\triangle ABC$, C is the right angle. If $\sin A = 0.4$, find $\cos B$. 16. _____
 a. 0.4 b. 0.6
 c. 0.2 d. 2.5

CHAPTER 5, FORM E, PAGE 3

17. Find $\sin A$, $\cos A$, and $\tan A$ for the figure below.

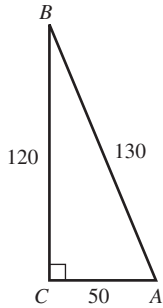

- a. $\sin A = \frac{12}{13}$, $\cos A = \frac{5}{13}$, $\tan A = \frac{12}{5}$
- b. $\sin A = \frac{5}{13}$, $\cos A = \frac{12}{13}$, $\tan A = \frac{12}{13}$
- c. $\sin A = \frac{12}{13}$, $\cos A = \frac{5}{13}$, $\tan A = \frac{12}{5}$
- d. $\sin A = \frac{12}{13}$, $\cos A = \frac{5}{13}$, $\tan A = \frac{5}{12}$

17. _____

18. Solve the triangle.

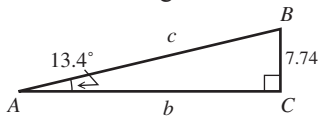

- a. $b = 32.5$, $c = 33.4$, $B = 76.6^\circ$
- b. $b = 7.1$, $c = 10.5$, $B = 76.6^\circ$
- c. $b = 8.1$, $c = 11.2$, $B = 46.3^\circ$
- d. $b = 29.6$, $c = 30.6$, $B = 75.3^\circ$

18. _____

19. A highway runs due north. A car traveling at 50 mph exits the highway on a bearing of 30° . After driving another 1.5 hours, what is the distance from the car to the highway?

- a. 75 mi
- b. $37.5\sqrt{3}$ mi
- c. 37.5 mi
- d. $75\sqrt{3}$ mi

19. _____

20. An observer deck of a ship is located at the origin of a coordinate system. Find the bearing of a buoy located at the point $(8, -8)$.

- a. 45°
- b. 135°
- c. 225°
- d. 315°

20. _____

CHAPTER 5, FORM F
COLLEGE ALGEBRA AND TRIGONOMETRY

NAME _____
 DATE _____

1. Find the supplement of an angle measuring 24° . 1. _____
 - a. 66°
 - b. 90°
 - c. 156°
 - d. 336°

2. Calculate $53^\circ 46' 38'' - 31^\circ 51' 25''$. 2. _____
 - a. $21^\circ 55' 13''$
 - b. $38^\circ 17' 13''$
 - c. $37^\circ 7' 13''$
 - d. $38^\circ 7' 13''$

3. Convert $15^\circ 24' 18''$ to decimal degrees. 3. _____
 - a. 15.3067°
 - b. 15.45°
 - c. 15.7°
 - d. 15.405°

4. Find the angle of smallest possible positive measure coterminal with -210° . 4. _____
 - a. 30°
 - b. 120°
 - c. 150°
 - d. 60°

5. The blade on a food processor is rotating 1800 times per minute. Through how many degrees will a point on the blade move in $\frac{2}{3}$ second? 5. _____
 - a. 1200°
 - b. 1200°
 - c. 7200°
 - d. 360°

6. Find the values of $\csc \theta$, $\sec \theta$, and $\cot \theta$ for the angle θ in standard position having $(3, -6)$ on its terminal side. 6. _____
 - a. $\csc \theta = \frac{\sqrt{5}}{2}$, $\sec \theta = \frac{\sqrt{5}}{2}$, $\cot \theta = \frac{1}{2}$
 - b. $\csc \theta = -2\sqrt{5}$, $\sec \theta = \sqrt{5}$, $\cot \theta = \frac{1}{2}$
 - c. $\csc \theta = \frac{2}{\sqrt{5}}$, $\sec \theta = \frac{1}{\sqrt{5}}$, $\cot \theta = -2$
 - d. $\csc \theta = -\frac{\sqrt{5}}{2}$, $\sec \theta = \sqrt{5}$, $\cot \theta = -\frac{1}{2}$

7. List the possible values of $\sin \theta$ if θ is a quadrantal angle. 7. _____
 - a. 0
 - b. $-2, -1, 1, 2$
 - c. $-1, 0, 1$
 - d. $-1, 1$

8. If $\sin \theta > 0$ and $\tan \theta < 0$, what is the sign of the value of $\sec \theta$? 8. _____
 - a. positive
 - b. negative
 - c. zero
 - d. undefined

CHAPTER 5, FORM F, PAGE 2

9. Which statement is impossible for all angles θ ? 9. _____
 a. $\cos \theta = 0$ b. $\tan \theta = 0$
 c. $\sec \theta = 0$ d. $\cot \theta = 0$
10. Find $\sin \beta$ and $\cos \beta$, given the following: 10. _____
 $\tan \beta = -\frac{2}{5}$ and $\csc \beta > 0$.
- a. $\sin \beta = \frac{2\sqrt{29}}{29}$, $\cos \beta = -\frac{5\sqrt{29}}{29}$
 b. $\sin \beta = -\frac{5\sqrt{29}}{29}$, $\cos \beta = -\frac{2\sqrt{29}}{29}$
 c. $\sin \beta = -\frac{2\sqrt{29}}{29}$, $\cos \beta = -\frac{5\sqrt{29}}{29}$
 d. $\sin \beta = \frac{5\sqrt{29}}{29}$, $\cos \beta = -\frac{2\sqrt{29}}{29}$
11. Find the reference angle for an angle of -202° . 11. _____
 a. 158° b. 22°
 c. -22° d. 68°
12. Evaluate $\tan 30^\circ$. 12. _____
 a. $\frac{1}{2}$ b. $\frac{\sqrt{3}}{3}$
 c. -2 d. $\frac{2\sqrt{3}}{3}$
13. Use a calculator to find $\csc 10.123^\circ$. Round your answer to three decimal places. 13. _____
 a. 5.690 b. 5.601
 c. 1.016 d. 1.556
14. Find the value of s in the interval $[0, 90^\circ]$ such that $\tan s = 3.5$. Round your answer to five decimal places. 14. _____
 a. 1.29250 b. 15.94540
 c. 16.60155 d. 74.05460
15. Exactly determine the angle between 0° and 360° such that $\sin \alpha = -\frac{\sqrt{3}}{2}$ and α is in quadrant III. 15. _____
 a. 210° b. 225°
 c. 240° d. 120°
16. In right triangle $\triangle ABC$, C is the right angle. If $\cos A = 0.8$, find $\cos B$. 16. _____
 a. 0.8 b. 0.6
 c. 1 d. 0.2

CHAPTER 5, FORM F, PAGE 3

17. Find $\sin B$, $\cos B$, and $\tan B$ for the figure below.

17. _____

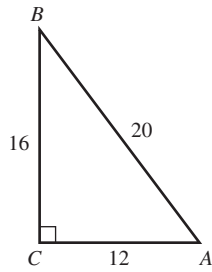

- a. $\sin B = \frac{3}{5}$, $\cos B = \frac{4}{5}$, $\tan B = \frac{3}{4}$
- b. $\sin B = \frac{4}{5}$, $\cos B = \frac{3}{5}$, $\tan B = \frac{3}{4}$
- c. $\sin B = \frac{4}{5}$, $\cos B = \frac{3}{5}$, $\tan B = \frac{4}{3}$
- d. $\sin B = \frac{5}{3}$, $\cos B = \frac{4}{3}$, $\tan B = \frac{4}{5}$

18. Solve the triangle.

18. _____

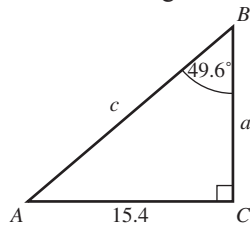

- a. $a = 20.2$, $c = 13.7$, $A = 41.4^\circ$
- b. $a = 18.1$, $c = 23.8$, $A = 54.6^\circ$
- c. $a = 13.1$, $c = 20.2$, $A = 40.4^\circ$
- d. $a = 13.1$, $c = 28.5$, $A = 51.4^\circ$

19. Two boats leave a pier traveling at 22 knots (nautical miles per hour). The first sails on a bearing of N 27° E and the second on a bearing of S 63° E. How far are the boats after 1.5 hours? Round answer to the nearest nautical mile.

19. _____

- a. 46.7 nautical mile
- b. 33 nautical mile
- c. 66 nautical mile
- d. 13.7 nautical mile

20. An observer deck of a ship is located at the origin of a coordinate system. Find the bearing of a buoy located at the point $(-5, 5)$.

20. _____

- a. 45°
- b. 135°
- c. 225°
- d. 315°

CHAPTER 6, FORM A
COLLEGE ALGEBRA AND TRIGONOMETRY

NAME _____
DATE _____

1. Convert 225° to radians. Leave answer as a multiple of π . 1. _____

2. Convert $\frac{14\pi}{5}$ radians to degrees. 2. _____

3. Which is larger, an angle measuring 60° or 1 radian? 3. _____

4. If $\theta = \frac{4\pi}{3}$, in what quadrant does the terminal side of \square lie? 4. _____

5. Find the length of the arc intercepted by a central angle of $\frac{\pi}{4}$ radians in a circle of radius 12 cm. Round your answer to the nearest tenth of a cm. 5. _____

6. Find the area of a sector of a circle intercepted by a central angle of 150° in a circle of radius 5.3 cm. Round answer to the nearest whole square cm. 6. _____

7. Determine $\tan s$ where s corresponds to the arc of the unit circle starting at $(1,0)$ and ending at $\left(\frac{\sqrt{2}}{2}, \frac{\sqrt{2}}{2}\right)$. 7. _____

8. Exactly determine $\cos\left(-\frac{5\pi}{4}\right)$. 8. _____

9. Use a calculator to find $\tan 5.096332$. 9. _____

10. Find the value of s in the interval $\left[0, \frac{\pi}{2}\right]$ such that $\sin s = .5033568$. 10. _____

11. A pulley has a radius of 14.50 cm. It takes 15 sec for 40 cm of belt to go around the pulley. Find the angular velocity of the pulley in radians per sec. 11. _____

12. Find all values of θ in the interval $[0, \square]$ such that $\sin 3\theta$ is equal to 0. 12. _____

13. Specify an interval starting at 0 that includes exactly two periods of the function $y = \sin 2x$. 13. _____

CHAPTER 6, FORM A, PAGE 2

- 14.** Give the amplitude, period, vertical translation, and phase shift of $y = 4 - \frac{3}{4}\sin(3x - \pi)$.

14. _____

Graph each defined function over a one-period interval. Identify asymptotes when applicable.

15. $y = 3 - 2 \cos x$

15.

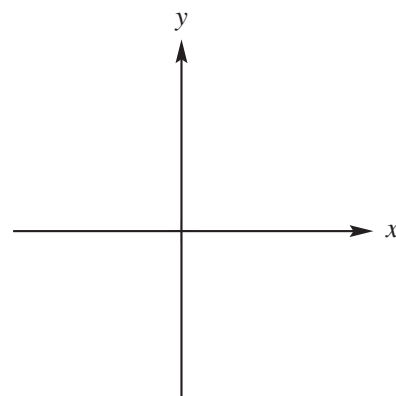

16. $y = -\sin\left(x - \frac{\pi}{2}\right)$

16.

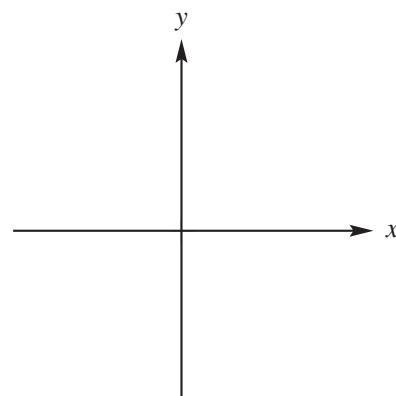

17. $y = 3 \tan x$

17.

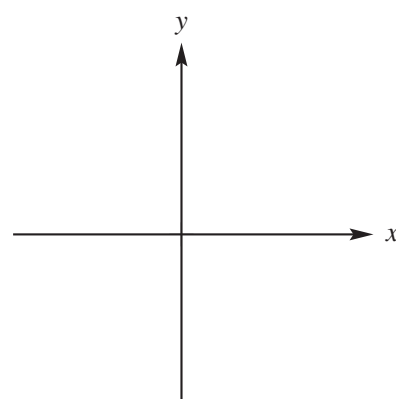

CHAPTER 6, FORM A, PAGE 3

18. An object oscillates according to the model $s(t) = 8 \sin \pi t$ where t is in seconds and $s(t)$ is in cm. Determine the frequency of the object. **18.** _____
19. An object's distance, in feet, from an equilibrium point is given by $f(t) = 25.1 \cos 3.5t$ where t is in seconds. Find, to the nearest tenth of a foot, the object's distance after 11 sec. **19.** _____
20. A weight is attached to a spring and pulled down 5 inches from its equilibrium position. Upon release, it takes 4 seconds for the weight to complete one oscillation. Find an equation that models the object's position after t seconds. **20.** _____

CHAPTER 6, FORM B
COLLEGE ALGEBRA AND TRIGONOMETRY

NAME _____

DATE _____

1. Convert 110° to radians. Leave answer as a multiple of π . 1. _____

2. Convert $\frac{8\pi}{3}$ radians to degrees. 2. _____

3. Which is larger, an angle measuring 100° or 2 radians? 3. _____

4. If $\theta = \frac{6\pi}{5}$, in what quadrant does the terminal side of \square lie? 4. _____

5. Find the length of the arc intercepted by a central angle of $\frac{\pi}{8}$ radians in a circle of radius 10 in. Round your answer to the nearest tenth of an inch. 5. _____

6. Find the area of a sector of a circle intercepted by a central angle of 120° in a circle of radius 18.6 in. 6. _____

7. Determine $\cos s$ where s corresponds to the arc of the unit circle starting at $(1,0)$ and ending at $\left(\frac{1}{3}, \frac{2\sqrt{2}}{3}\right)$. 7. _____

8. Exactly determine $\tan \frac{7\pi}{3}$. 8. _____

9. Evaluate $\tan \frac{5\pi}{3}$. Give the exact value and rationalize denominator if applicable. 9. _____

10. Find the value of s in the interval $\left[0, \frac{\pi}{2}\right]$ such that $\sin s = .790325578$. 10. _____

11. Find the linear velocity of a point on the edge of a drum rotating 52 times per minute. The diameter of the drum is 16.0 in. 11. _____

12. Find all values of \square in the interval $[0, 4\square]$ such that $\cos \frac{1}{2}\theta$ is equal to 0. 12. _____

13. Specify an interval starting at 0 that includes exactly two periods of the function $y = \sin \frac{1}{2}x$. 13. _____

CHAPTER 6, FORM B, PAGE 2

14. Give the amplitude, period, vertical translation, and phase shift of $y = 3 - \frac{5}{4} \cos(4x + \pi)$.

14. _____

Graph each defined function over a one-period interval. Identify asymptotes when applicable.

15. $y = \sin\left(x + \frac{\pi}{3}\right)$

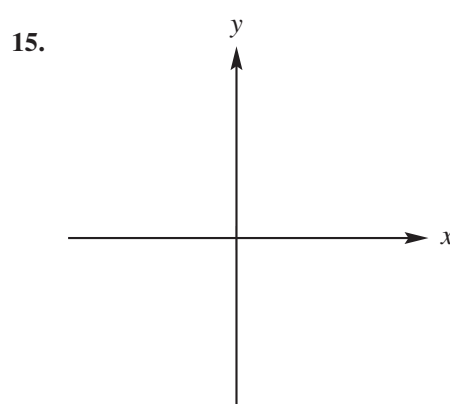

16. $y = \frac{1}{4} \sec x$

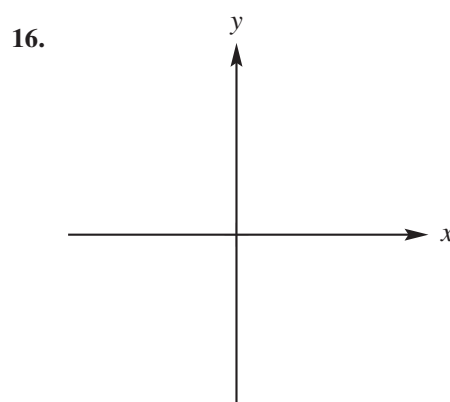

17. $y = 2 \tan\left(x - \frac{\pi}{2}\right)$

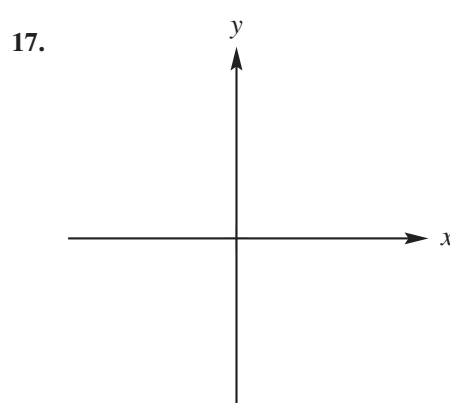

CHAPTER 6, FORM B, PAGE 3

18. An object oscillates according to the model $s(t) = 12 \cos 2.5\pi t$ where t is in seconds and $s(t)$ is in cm. Determine the frequency of the object. **18.** _____
19. An object's distance, in feet, from an equilibrium point is given by $f(t) = 12 \sin \pi t$ where t is in seconds. Find, to the nearest tenth of a foot, the object's distance after 2.3 sec. **19.** _____
20. A weight is attached to a spring and pulled down 4 inches from its equilibrium position. Upon release, it takes 2.5 seconds for the weight to complete one oscillation. Find an equation that models the object's position after t seconds. **20.** _____

CHAPTER 6, FORM C
COLLEGE ALGEBRA AND TRIGONOMETRY

NAME _____
DATE _____

1. Convert 480° to radians. Leave answer as a multiple of π . 1. _____

2. Convert $-\frac{\pi}{5}$ radians to degrees. 2. _____

3. Which is larger, an angle measuring 25° or $\frac{\pi}{7}$ radians? 3. _____

4. If $\theta = \frac{4\pi}{5}$, in what quadrant does the terminal side of \square lie? 4. _____

5. Find the length of the arc intercepted by a central angle of 60° in a circle of radius 8 in. Round your answer to the nearest tenth of an inch. 5. _____

6. Find the area of a sector of a circle intercepted by a central angle of 75° in a circle of radius 6.4 cm. 6. _____

7. Determine $\sec s$ where s corresponds to the arc of the unit circle starting at (1,0) and ending at (0.8, 0.6). 7. _____

8. Exactly determine $\sec \frac{\pi}{6}$. 8. _____

9. Use a calculator to find $\tan 1.7592$. 9. _____

10. Find the value of s in the interval $\left[0, \frac{\pi}{2}\right]$ such that $\sin s = 7.4506689$. 10. _____

11. A pulley has a radius of 9.60 cm. It takes 8 sec for 32 cm of belt to go around the pulley. Find the angular velocity of the pulley in radians per sec. 11. _____

12. Find all values of θ in the interval $[0, 2\square]$ such that $\cos \frac{1}{3}\theta$ is equal to 0. 12. _____

13. Specify an interval starting at 0 that includes exactly three periods of the function $y = \cos 4x$. 13. _____

CHAPTER 6, FORM C, PAGE 2

14. Give the amplitude, period, vertical translation, and phase shift of $y = 2 \sec 2\left(x + \frac{\pi}{3}\right)$.

14. _____

Graph each function over a one-period interval. Identify asymptotes when applicable.

15. $y = -4 \sin x$

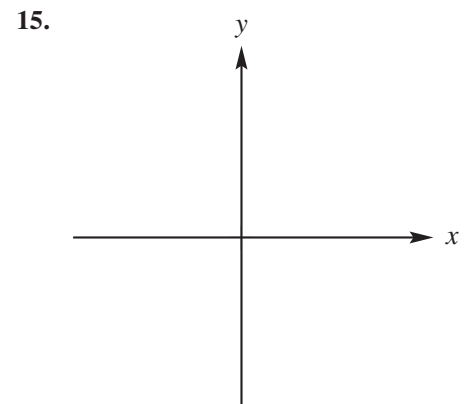

16. $y = \frac{1}{4} \tan x$

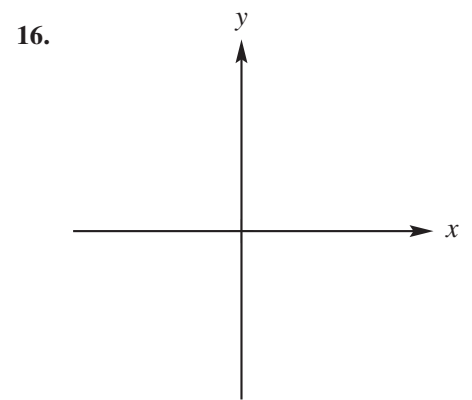

17. $y = -2 + \sin 2x$

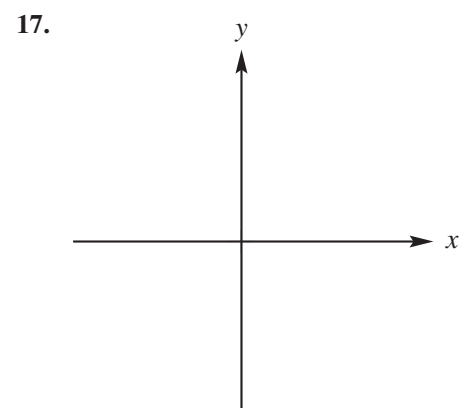

CHAPTER 6, FORM C, PAGE 3

18. An object oscillates according to the model $s(t) = 10 \cos 3t$ where t is in seconds and $s(t)$ is in cm. Determine the frequency of the object. **18.** _____
19. An object's distance, in feet, from an equilibrium point is given by $f(t) = 125 \sin 2\pi t$ where t is in seconds. Find, to the nearest tenth of a foot, the object's distance after 10.1 sec. **19.** _____
20. A weight is attached to a spring and pulled down 6cm from its equilibrium position. Upon release, it takes 1 second for the weight to complete one oscillation. Find an equation that models the object's position after t seconds. **20.** _____

CHAPTER 6, FORM D
COLLEGE ALGEBRA AND TRIGONOMETRY

NAME _____

DATE _____

1. Convert 45° to radians. Leave answer as a multiple of π . 1. _____

2. Convert $\frac{5\pi}{36}$ radians to degrees. 2. _____

3. Which is larger, an angle measuring 35° or $\frac{1}{2}$ radian? 3. _____

4. If $\theta = \frac{8\pi}{9}$, in what quadrant does the terminal side of θ lie? 4. _____

5. In a circle, the length of the arc intercepted by a central angle of 1.2 radians is 48 cm. Find the radius of the circle. 5. _____

6. Find the area of a sector of a circle intercepted by a central angle of 59° in a circle of radius 5.8 cm. 6. _____

7. Determine $\sin s$ where s corresponds to the arc of the unit circle starting at $(1,0)$ and ending at $\left(-\frac{1}{4}, \frac{\sqrt{15}}{16}\right)$. 7. _____

8. Exactly determine $\sec \frac{7\pi}{6}$. 8. _____

9. Use a calculator to find $\sin 3.45098$. 9. _____

10. Find the value of s in the interval $\left[0, \frac{\pi}{2}\right]$ such that $\tan s = 7.4506689$. 10. _____

11. Find the linear velocity of a point on the edge of a wheel rotating 32 times per minute. The diameter of the wheel is 12.5 m. 11. _____

12. Find all values of θ in the interval $[0, 2\pi]$ such that $\tan 2\theta$ is equal to 0. 12. _____

13. Specify an interval starting at 0 that includes exactly two periods of the function $y = \cos 4x$. 13. _____

CHAPTER 6, FORM D, PAGE 2

14. Give the amplitude, period, vertical translation, and phase shift of $y = 5 - \frac{1}{3} \sin(4x - \pi)$.

14. _____

Graph each defined function over a one-period interval. Identify asymptotes when applicable.

15. $y = \frac{3}{2} \sin x$

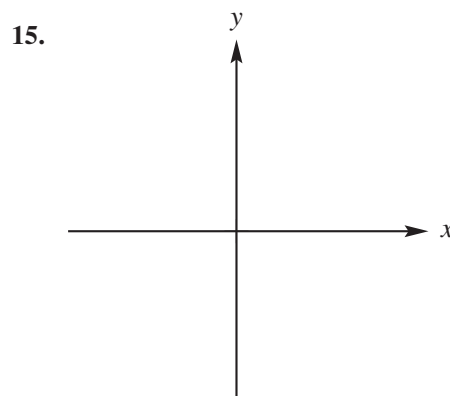

16. $y = -\frac{1}{2} \cot \frac{1}{2}x$

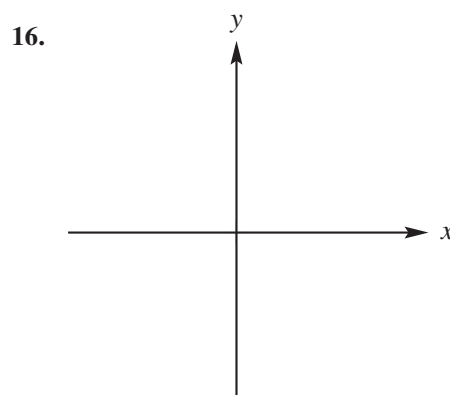

17. $y = 2 - \sin\left(\frac{x}{2} + \frac{\pi}{2}\right)$

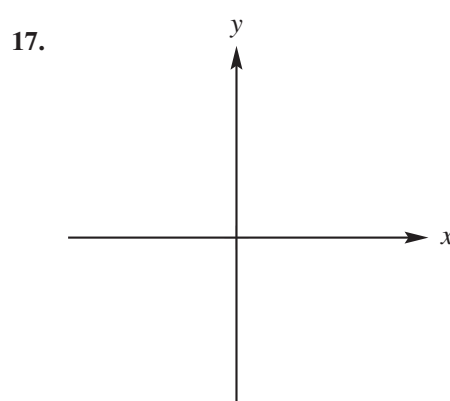

CHAPTER 6, FORM D, PAGE 3

18. An object oscillates according to the model $s(t) = 6 \cos 2t$ where t is in seconds and $s(t)$ is in cm. Determine the frequency of the object. **18.** _____
19. An object's distance, in feet, from an equilibrium point is given by $f(t) = 16 \sin 2.6t$ where t is in seconds. Find, to the nearest tenth of a foot, the object's distance after 10 sec. **19.** _____
20. A weight is attached to a spring and pulled down 2.3 inches from its equilibrium position. Upon release, it takes 2.5 seconds for the weight to complete one oscillation. Find an equation that models the object's position after t seconds. **20.** _____

CHAPTER 6, FORM E
COLLEGE ALGEBRA AND TRIGONOMETRY

NAME _____
DATE _____

1. $-60^\circ =$ ____ radians 1. _____
 - a. $\frac{\pi}{3}$
 - b. $-\frac{\pi}{3}$
 - c. $-\frac{2\pi}{3}$
 - d. None of these

2. $-\frac{53\pi}{18} =$ ____ degrees 2. _____
 - a. -530°
 - b. -225°
 - c. 150°
 - d. None of these

3. Which of the following angle measurements is largest? 3. _____
 - a. 3 radians
 - b. π radians
 - c. 200°
 - d. 2 radians

4. If $\theta = \frac{5\pi}{3}$, which quadrant does the terminal side of θ lie? 4. _____
 - a. I
 - b. II
 - c. III
 - d. IV

5. Find the length of the arc intercepted by a central angle of 1.5 radians in a circle of radius 9 cm. 5. _____
 - a. 6 cm
 - b. 13.5π cm
 - c. 6π cm
 - d. 13.5 cm

6. Find the area of a sector of a circle intercepted by a central angle of 210° in a circle of radius 3.1 cm. 6. _____
 - a. 17.6 cm^2
 - b. 32.5 cm^2
 - c. 20.8 cm^2
 - d. 41.1 cm^2

7. Determine $\tan s$ where s corresponds to the arc of the unit circle starting at (1,0) and ending at $\left(\frac{\sqrt{2}}{2}, \frac{\sqrt{2}}{2}\right)$. 7. _____
 - a. 0
 - b. -1
 - c. 1
 - d. undefined

8. Exactly determine $\tan\left(-\frac{7\pi}{4}\right)$. 8. _____
 - a. 1
 - b. $-\frac{\sqrt{2}}{2}$
 - c. $\sqrt{2}$
 - d. $\frac{\sqrt{2}}{2}$

9. Use a calculator to find $\sin 4.2143$. 9. _____
 - a. $-.8785$
 - b. $-.4777$
 - c. $.3672$
 - d. 1.8388

CHAPTER 6, FORM E, PAGE 2

10. Find the value of t in the interval $\left[\frac{3\pi}{2}, 2\pi\right]$ such that $\sec t = 2.4183$. 10. _____
- a. 4.7231 b. 4.8329
c. 5.0328 d. 5.1387
11. A pulley has a radius of 4.3 cm. It takes 6 sec for 20 cm of belt to go around the pulley. Find the angular velocity of the pulley in radians per sec. 11. _____
- a. .5896 b. .7752
c. 1.2135 d. 1.4353
12. Find all values of θ in the interval $[0, \pi]$ such that $\sin 2\theta$ is equal to 0. 12. _____
- a. $0, \pi$ b. 0
c. $0, \frac{\pi}{2}, \pi$ d. $0, \frac{\pi}{4}, \frac{\pi}{2}$
13. Specify an interval starting at 0 that includes exactly two periods of the function $y = \sin \frac{1}{2}x$. 13. _____
- a. $[0, \pi]$ b. $[0, 8\pi]$
c. $[0, 2\pi]$ d. $[0, 4\pi]$
14. For $y = 3 + \cot \frac{x + \pi}{4}$, give the period (P), vertical translation (V), and phase shift (PS), as applicable. 14. _____
- a. P: 4, V: -3, PS: $\frac{\pi}{4}$ to the right
b. P: 4, V: 3, PS: to the left
c. P: 2, V: none, PS: 3 to the right
d. P: , V: none, PS: $\frac{\pi}{4}$ to the left

CHAPTER 6, FORM E, PAGE 3

Choose the graph that best describes the function.

15. $y = \cos\left(x + \frac{\pi}{6}\right)$

15. _____

a.

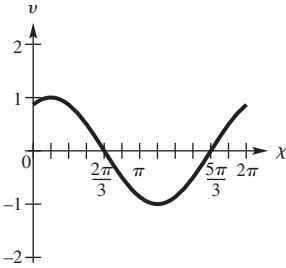

b.

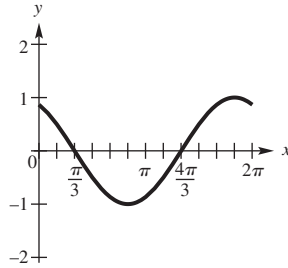

c.

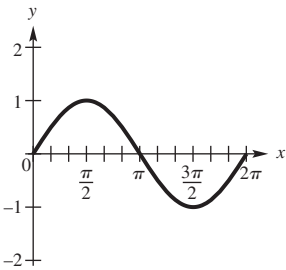

d.

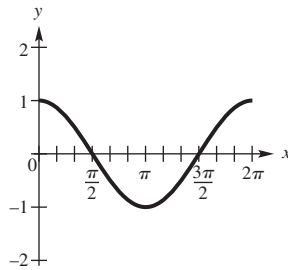

16. $y = -2 \sec(x)$

16. _____

a.

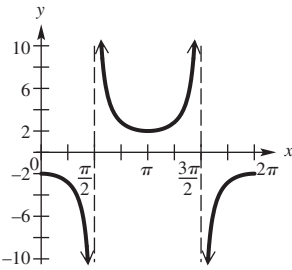

b.

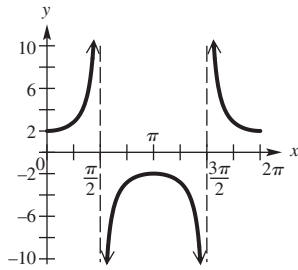

c.

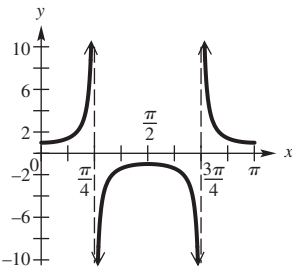

d.

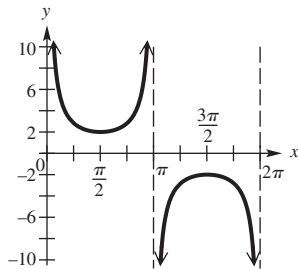

CHAPTER 6, FORM E, PAGE 4

17. $y = 3 + \sin\left(x + \frac{\pi}{4}\right)$

17. _____

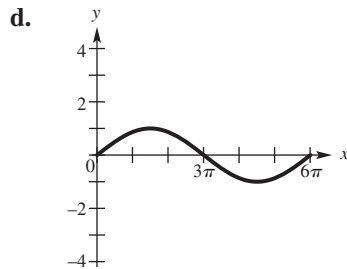
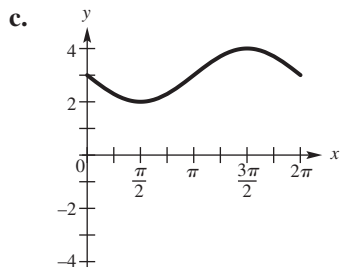
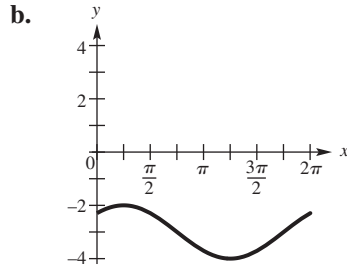
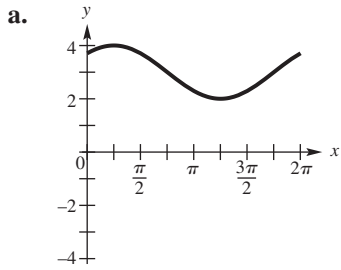

18. An object oscillates according to the model $s(t) = 2 \sin \frac{\pi}{2}t$ where t is in seconds and $s(t)$ is in cm. Determine the frequency of the object.

18. _____

- a. $\frac{1}{4}$
- b. 4
- c. 4π
- d. $\frac{1}{4\pi}$

19. An object's distance, in feet, from an equilibrium point is given by $f(t) = 100 \cos \pi t$ where t is in seconds. Find, to the nearest tenth of a foot, the object's distance after 3.7 sec.

19. _____

- a. 60 ft
- b. 84.8 ft
- c. 58.8 ft
- d. 100 ft

20. A weight is attached to a spring and pulled down 3 inches from its equilibrium position. Upon release, it takes π seconds for the weight to complete one oscillation. Find an equation that models the object's position after t seconds.

20. _____

- a. $y = 3 \cos 2\pi t$
- b. $y = \pi \cos 3t$
- c. $y = 3 \sin 2t$
- d. $y = 3 \cos 2t$

CHAPTER 6, FORM F
COLLEGE ALGEBRA AND TRIGONOMETRY

NAME _____
DATE _____

1. Electrical wire is being wound around a drum with radius of 0.50 meters. How much wire would be wound around the drum if it is rotated through an angle of 288° ?
a. 2.61 m b. 2.51 m
c. 2.31 m d. 2.41 m
1. _____

2. Convert 220° to radians.
a. $\frac{9\pi}{13}$ b. $\frac{12\pi}{23}$
c. $\frac{11\pi}{9}$ d. None of these
2. _____

3. Which of the following angle measurements is largest?
a. 2 radians b. $\frac{\pi}{2}$ radians
c. 100° d. 110°
3. _____

4. If $\theta = \frac{6\pi}{5}$, which quadrant does the terminal side of θ lie?
a. I b. II
c. III d. IV
4. _____

5. Find the length of the arc intercepted by a central angle of 30° in a circle of radius 10 in. Round your answer to the nearest tenth of an inch.
a. 300 in b. 5.2 in
c. 2.6 in d. 1.7 in
5. _____

6. Convert $-\frac{11\pi}{9}$ radians to degrees.
a. 135° b. 220°
c. 300° d. None of these
6. _____

7. Determine $\cot s$ where s corresponds to the arc of the unit circle starting at (1,0) and ending at $\left(-\frac{1}{2}, \frac{\sqrt{3}}{2}\right)$.
a. $-\frac{\sqrt{3}}{3}$ b. $\sqrt{3}$
c. $-\sqrt{3}$ d. $\frac{\sqrt{3}}{3}$
7. _____

8. Exactly determine $\cos \frac{5\pi}{4}$.
a. $\frac{\sqrt{2}}{2}$ b. $-\frac{\sqrt{2}}{2}$
c. $\frac{1}{2}$ d. $-\frac{\sqrt{3}}{2}$
8. _____

CHAPTER 6, FORM F, PAGE 2

9. Use a calculator to find $\tan 4.9382$. 9. _____
 a. -4.3530 b. $-.2297$
 c. $.2239$ d. 4.4663
10. Find the area of a sector of a circle intercepted by a central angle of 245° in a circle of radius 9.8 in. 10. _____
 a. 178.6 in.^2 b. 205.3 in.^2
 c. 213.4 in.^2 d. 332.4 in.^2
11. Find the linear velocity of a point on the edge of a wheel rotating 48 times per min. The diameter of the wheel is 27 in. 11. _____
 a. 108 ft/min b. 221 ft/min
 c. 339 ft/min d. 453 ft/min
12. Find all values of θ in the interval $[0, 4\pi]$ such that $\cos \frac{1}{2}\theta$ is equal to 0. 12. _____
 a. $0, 2\pi, 4\pi$ b. $\pi, 3\pi$
 c. $0, \pi, 3\pi$ d. π
13. Specify an interval starting at 0 that includes exactly three periods of the function $y = \sin \pi x$. 13. _____
 a. $[0, 1]$ b. $[0, 8]$
 c. $[0, 2]$ d. $[0, 4]$
14. Give the amplitude (A), period (P), vertical translation (V), and phase shift (PS) of $y = 4 + 4 \cos \left(x - \frac{\pi}{4} \right)$. 14. _____
 a. A: 4, P: , V: 4, PS: none
 b. A: 4, P: 2, V: 4, PS: $\frac{\pi}{4}$ to the right
 c. A: 4, P: 2, V: -4, PS: none
 d. A: 1, P: 2, V: -4, PS: $\frac{\pi}{4}$ to the left

CHAPTER 6, FORM F, PAGE 3

Choose the graph that best describes each function.

15. $y = 1 + \tan\left(x + \frac{\pi}{3}\right)$

15. _____

a.

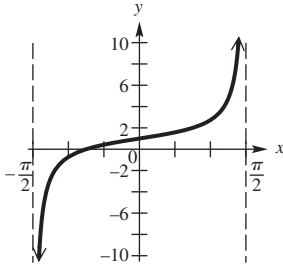

b.

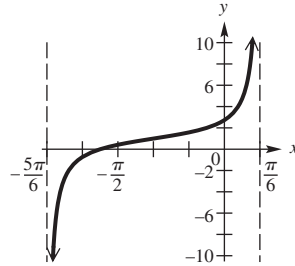

c.

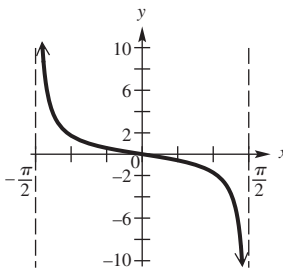

d.

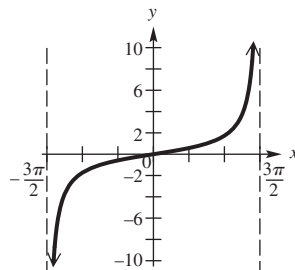

16. $y = 4 - 4 \sin(2x)$

16. _____

a.

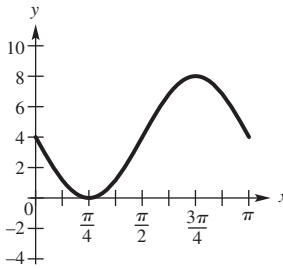

b.

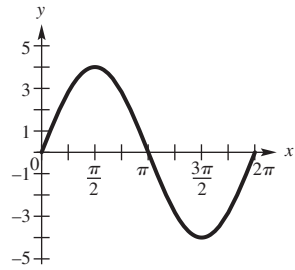

c.

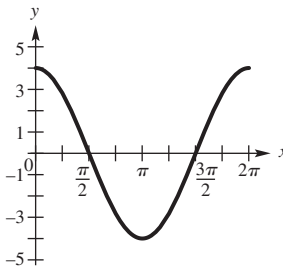

d.

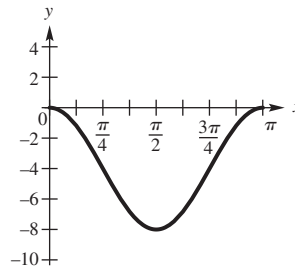

CHAPTER 6, FORM F, PAGE 4

17. $y = 6 \cos\left(3x + \frac{\pi}{3}\right)$

17. _____

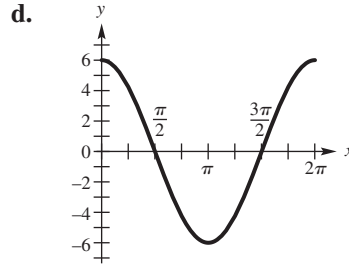
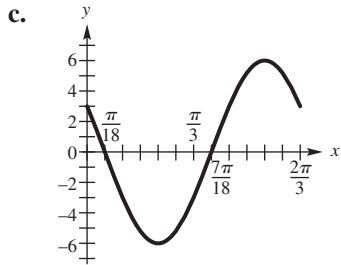
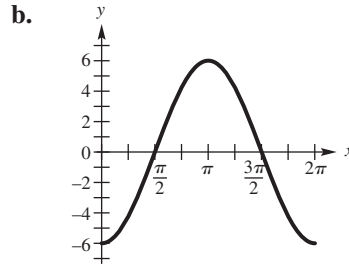
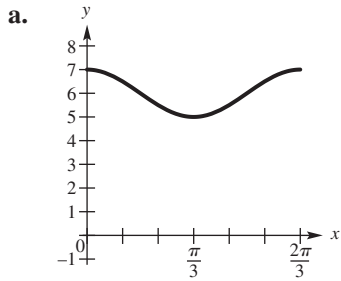

18. An object oscillates according to the model $s(t) = 4 \cos 2\pi t$ where t is in seconds and $s(t)$ is in cm. Determine the frequency of the object.

18. _____

- a. 1
- b. $\frac{1}{2}$
- c. 2
- d. 2π

19. An object's distance, in inches, from an equilibrium point is given by $f(t) = 20 \cos 2.3t$ where t is in seconds. Find, to the nearest tenth of an inch, the object's distance after 1 minute.

19. _____

- a. 19.5 in
- b. 13.3 in
- c. 4.6 in
- d. 20 in

20. A weight is attached to a spring and pulled down 6.5 cm from its equilibrium position. Upon release, it takes 6 seconds for the weight to complete one oscillation. Find an equation that models the object's position after t seconds.

20. _____

- a. $y = 6.5 \sin \frac{\pi}{3}t$
- b. $y = 6 \sin 2\pi t$
- c. $y = 6.5 \cos \frac{\pi}{3}t$
- d. $y = 6 \cos 2\pi t$

**CHAPTER 7, FORM A
COLLEGE ALGEBRA AND TRIGONOMETRY**

NAME _____
DATE _____

1. Given $\tan x = \sqrt{3}$, where $0 < x < \frac{\pi}{2}$, on a separate sheet of paper use trigonometric identities to show that $\sin x = \frac{\sqrt{3}}{2}$ and $\cos x = \frac{1}{2}$.

1. See separate page.

2. Express $\sec x + \cot x$ in terms of $\sin x$ and $\cos x$, and simplify.

2. _____

3. Let $\sin s = \frac{1}{3}$, with s in quadrant II, and let $\cos t = \frac{3}{4}$, with t in quadrant I. Find each of the following.

- a. $\cos(s + t)$
b. $\sin(s - t)$

3. a. _____
b. _____

4. Suppose $x = \frac{\pi}{12}$. Use a difference identity to find the exact value of $\sin x$.

4. _____

For Exercises 5 and 6, use a graphing utility to graph each expression.

- a. Use the graph to conjecture an identity.
b. Verify your conjecture on a separate sheet of paper.

5. $\frac{\cos^2 x - \cos(2x)}{\sin x}$

5. a. _____

6. $-1 + \cos^2 x + \sin^2 x + \cos(2x)$

b. See separate page.
6. a. _____
b. See separate page.

For Exercises 7 and 8, use a separate page to verify that each equation is an identity.

7. $\frac{1}{\tan \gamma + \cot \gamma} = \sin \gamma \cos \gamma$

7. See separate page.

8. $2 \tan x \sec x \csc x = 2 + 2 \tan^2 x$

8. See separate page.

9. Use an identity to write $2 \sin\left(\frac{\pi}{2} + \theta\right)$ as a trigonometric function of θ alone.

9. _____

CHAPTER 7, FORM A, PAGE 2

10. Graph $y = \cos^{-1} x$, and indicate the coordinates of three points on the graph. Give the domain and range.

10. Domain: _____
Range: _____

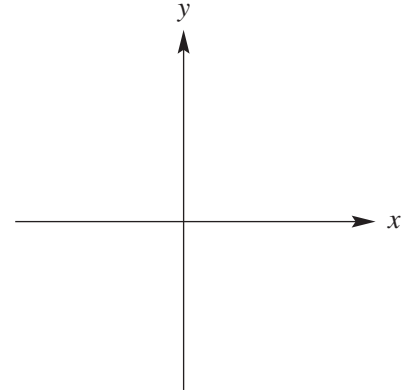

11. Give the exact real number value of y .

a. $y = \cos^{-1}\left(\frac{\sqrt{3}}{2}\right)$

11. a. _____

b. $y = \operatorname{arccot}\left(-\frac{\sqrt{3}}{3}\right)$

- b. _____

In Exercises 12 and 13, find each exact value.

12. $\cos\left(\arcsin\frac{1}{4}\right)$

12. _____

13. $\sin\left[\arccos\frac{1}{3} + \arcsin\left(-\frac{2}{5}\right)\right]$

13. _____

14. Write $\tan(\arccos u)$ as a non-trigonometric expression in u .

14. _____

In Exercises 15 and 16, solve each equation algebraically in the interval $[0^\circ, 360^\circ)$. For Exercise 16, use a calculator and round the answer to three decimal places.

15. $\cos^3 \theta = \cos \theta$

15. _____

16. $6 \sin \theta + 2 = 0$

16. _____

In Exercises 17 and 18, solve each equation algebraically in the interval $[0, 2\pi)$.

17. $\cos^2 x + 2 \cos x + 1 = 0$

17. _____

18. $\sin \frac{1}{2}x = \cos x$

18. _____

CHAPTER 7, FORM A, PAGE 3

In Exercises 19 and 20, solve the equation for x .

19. $5y = 4 \tan x + 1$

19. _____

20. $\arccos x - \operatorname{arccot} \frac{6}{5} = 0$

20. _____

CHAPTER 7, FORM B
COLLEGE ALGEBRA AND TRIGONOMETRY

NAME _____
 DATE _____

1. Given $\cos x = -\frac{3}{4}$, with x in quadrant II, on a separate sheet of paper use trigonometric identities to show that $\sin x = \frac{\sqrt{7}}{4}$ and $\tan x = -\frac{\sqrt{7}}{3}$.

1. See separate page.

2. Express $\frac{\sec x \csc x}{\tan x \cot x}$ in terms of $\sin x$ and $\cos x$, and simplify.

2. _____

3. Let $\sin s = -\frac{2}{3}$, with s in quadrant III, and let $\cos t = -\frac{1}{3}$, with t in quadrant II. Find each of the following.

a. $\sin 2s$

3. a. _____

b. $\cos(s - t)$

b. _____

4. Suppose $x = \frac{5\pi}{12}$. Use a sum identity to find the exact value of $\sin x$.

4. _____

For Exercises 5 and 6, use a graphing utility to graph each expression.

- a. Use the graph to conjecture an identity.
 b. Verify your conjecture on a separate sheet of paper.

5. $\frac{\cos x}{1 - \sin^2 x}$

5. a. _____

b. See separate page.

6. $\csc x - \cos x \cot x$

6. a. _____

b. See separate page.

For Exercises 7 and 8, use a separate page to verify that each equation is an identity.

7. $\sin 2\beta = 2\sin^3 \beta \cos \beta + 2\sin \beta \cos^3 \beta$

7. See separate page.

8. $2 \tan \alpha \sin \alpha \sec \alpha = 2 \sec^2 \alpha - 2$

8. See separate page.

9. Use an identity to write $\cos(\pi + \theta)$ as a trigonometric function of θ alone.

9. _____

CHAPTER 7, FORM B, PAGE 2

10. Graph $y = \tan^{-1} x$, and indicate the coordinates of three points on the graph. Give the domain and range.

10. Domain: _____
Range: _____

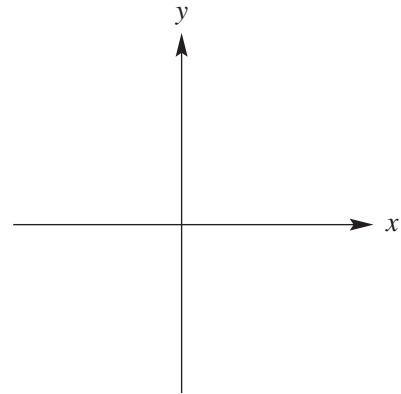

11. Give the exact real number value of y .

a. $y = \cot^{-1} 1$

11. a. _____

b. $y = \arctan(-\sqrt{3})$

b. _____

In Exercises 12 and 13, find each exact value.

12. $\sin(\arctan 2)$

12. _____

13. $\sin\left[\arccos\left(-\frac{2}{3}\right) + \arcsin\frac{1}{4}\right]$

13. _____

14. Write $\cos(\arctan u)$ as a non-trigonometric expression in u .

14. _____

In Exercises 15 and 16, solve each equation algebraically in the interval $[0^\circ, 360^\circ)$. For Exercise 16, use a calculator and round the answer to three decimal places.

15. $2 \cos \theta + \sqrt{3} = 0$

15. _____

16. $\sin^2 \theta = \frac{1}{3}$

16. _____

In Exercises 17 and 18, solve each equation algebraically in the interval $[0, 2\pi)$.

17. $2 \cos^2 x + 1 = 3 \cos x$

17. _____

18. $\sin \frac{x}{2} = 1 - \sin \frac{x}{2}$

18. _____

In Exercises 19 and 20, solve the equation for x .

19. $3y = 5 \sin(x - 4)$

19. _____

20. $\sin^{-1} 2x = \frac{\pi}{4}$

20. _____

CHAPTER 7, FORM C
COLLEGE ALGEBRA AND TRIGONOMETRY

NAME _____

DATE _____

1. Given $\sin x = \frac{1}{3}$, with x in quadrant II, on a separate sheet of paper use trigonometric identities to show that $\cos x = -\frac{2\sqrt{2}}{3}$ and $\tan x = -\frac{\sqrt{2}}{4}$.

1. See separate page.

2. Express $\csc^2 x(\cos x + \sin x)(\cos x - \sin x)$ in terms of $\sin x$ and $\cos x$, and simplify.

2. _____

3. Let $\sin s = -\frac{1}{4}$, with s in quadrant IV, and let $\cos t = -\frac{2}{5}$, with t in quadrant II. Find each of the following.

a. $\cos 2s$

3. a. _____

b. $\sin(s - t)$

b. _____

4. Suppose $x = \frac{11\pi}{12}$. Use a sum identity to find the exact value of $\sin x$.

4. _____

For Exercises 5 and 6, use a graphing utility to graph each expression.

- a. Use the graph to conjecture an identity.
 b. Verify your conjecture on a separate sheet of paper.

5. $\frac{2\cos^2 x - 1}{\sin(2x)}$

5. a. _____

b. See separate page.

6. $\tan x \sec x \cot x$

6. a. _____

b. See separate page.

For Exercises 7 and 8, use a separate page to verify that each equation is an identity.

7. $\frac{\cos^2 t}{1 - \sin t} = 1 + \sin t$

7. See separate page.

8. $2 \cot \alpha \sin \alpha \cos \alpha = 2 - 2 \sin^2 \alpha$

8. See separate page.

9. Use an identity to write $\sin\left(\theta - \frac{\pi}{4}\right)$ as a sum or difference of trigonometric functions of θ alone.

9. _____

CHAPTER 7, FORM C, PAGE 2

10. Graph $y = \sec^{-1} x$, and indicate the coordinates of three points on the graph. Give the domain and range.

10. Domain: _____
Range: _____

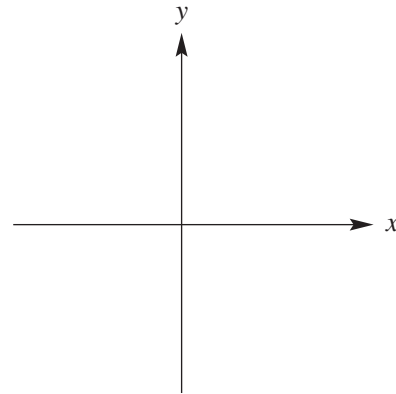

11. Give the exact real number value of y .

a. $y = \tan^{-1}(-1)$

11. a. _____

b. $y = \sec^{-1}(1)$

b. _____

In Exercises 12 and 13, find each exact value.

12. $\csc\left(\arcsin\frac{9}{15}\right)$

12. _____

13. $\cos\left[\arcsin\left(-\frac{3}{4}\right) + \arccos\frac{2}{3}\right]$

13. _____

14. Write $\sin(\cos^{-1} u)$ as a non-trigonometric expression in u .

14. _____

In Exercises 15 and 16, solve each equation algebraically in the interval $[0^\circ, 360^\circ)$. For Exercise 16, use a calculator and round the answer to three decimal places.

15. $2 \sec \theta - 4 = 0$

15. _____

16. $3 \sin^2 \theta = 2$

16. _____

In Exercises 17 and 18, solve each equation algebraically in the interval $[0, 2\pi)$.

17. $\sin^2 x = -\sin x$

17. _____

18. $\csc^5 x = 4 \csc x$

18. _____

In Exercises 19 and 20, solve the equation for x .

19. $7y = 3 \cos(x + 4)$

19. _____

20. $\arcsin x = \arccos\frac{7}{25}$

20. _____

CHAPTER 7, FORM D
COLLEGE ALGEBRA AND TRIGONOMETRY

NAME _____

DATE _____

1. Given $\sin x = -\frac{7}{25}$, with x in quadrant III, on a separate sheet of paper use trigonometric identities to show that $\cos x = -\frac{24}{25}$ and $\tan x = \frac{7}{24}$.
2. Express $\tan x \csc x$ in terms of $\sin x$ and $\cos x$, and simplify.
3. Let $\sin s = -\frac{2}{5}$, with s in quadrant IV, and let $\cos t = -\frac{1}{4}$, with t in quadrant II. Find each of the following.
 - a. $\cos(s - t)$
 - b. $\sin 2s$
4. Suppose $x = \frac{7\pi}{12}$. Use a difference identity to find the exact value of $\sin x$.

1. See separate page.

2. _____

3. a. _____

b. _____

4. _____

For Exercises 5 and 6, use a graphing utility to graph each expression.

- a. Use the graph to conjecture an identity.
- b. Verify your conjecture on a separate sheet of paper.

5. $\frac{\cos\left(\frac{\pi}{2} - x\right)}{\tan x}$

5. a. _____

b. See separate page.

6. $\sin x \tan x - \sec x$

6. a. _____

b. See separate page.

For Exercises 7 and 8, use a separate page to verify that each equation is an identity.

7. $\sin \gamma \cos \gamma = \frac{\cos \gamma - \cos^3 \gamma}{\sin \gamma}$

7. See separate page.

8. $2 + 2 \cot^2 x = 2 \cot x \sec x \csc x$

8. See separate page.

9. Use an identity to write $\cos\left(\theta + \frac{\pi}{3}\right)$ as a sum or difference of trigonometric functions of θ alone.

9. _____

CHAPTER 7, FORM D, PAGE 2

10. Graph $y = \csc^{-1} x$, and indicate the coordinates of three points on the graph. Give the domain and range.

10. Domain: _____
Range: _____

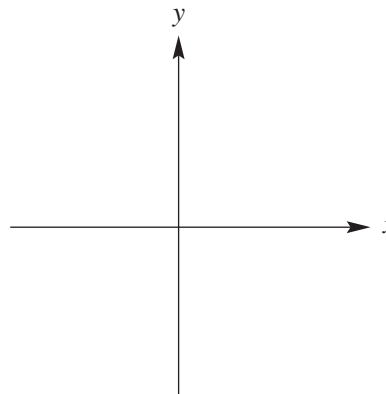

11. Give the exact real number value of y .

a. $y = \sin^{-1}\left(\frac{1}{2}\right)$

11. a. _____

b. $y = \tan^{-1}\left(\frac{\sqrt{3}}{3}\right)$

b. _____

In Exercises 12 and 13, find each exact value.

12. $\cot\left(\arccos\frac{2}{3}\right)$

12. _____

13. $\cos\left(\arcsin\frac{3}{7} - \arccos\frac{2}{5}\right)$

13. _____

14. Write $\sin(\tan^{-1} u)$ as a non-trigonometric expression in u .

14. _____

In Exercises 15 and 16, solve each equation algebraically in the interval $[0^\circ, 360^\circ)$. For Exercise 16, use a calculator and round the answer to three decimal places.

15. $2 \sin \theta - \sqrt{2} = 0$

15. _____

16. $\cos^2 \theta = \frac{2}{5}$

16. _____

In Exercises 17 and 18, solve each equation algebraically in the interval $[0, 2\pi)$.

17. $2 \sin^2 x - \sin x = 1$

17. _____

18. $\cot \frac{x}{2} - \sin x = 0$

18. _____

CHAPTER 7, FORM D, PAGE 3

In Exercises 19 and 20, solve the equation for x .

19. $y = -2 \csc \frac{x}{2}$

19. _____

20. $\arctan x = \arcsin \frac{2}{3}$

20. _____

CHAPTER 7, FORM E
COLLEGE ALGEBRA AND TRIGONOMETRY

NAME _____
 DATE _____

Choose the best answer.

1. Given $\tan x = -\frac{3}{4}$ and $90^\circ < x < 180^\circ$, find the remaining five trigonometric functions of x . 1. _____
- a. $\sin x = \frac{3}{5}, \cos x = -\frac{4}{5}, \csc x = \frac{5}{3}, \sec x = -\frac{5}{4}, \cot x = -\frac{4}{3}$
- b. $\sin x = -\frac{3}{5}, \cos x = \frac{4}{5}, \csc x = \frac{5}{3}, \sec x = -\frac{5}{4}, \cot x = -\frac{4}{3}$
- c. $\sin x = -\frac{4}{5}, \cos x = \frac{4}{5}, \csc x = \frac{5}{3}, \sec x = \frac{5}{3}, \cot x = \frac{3}{4}$
- d. $\sin x = -\frac{4}{5}, \cos x = \frac{3}{5}, \csc x = -\frac{5}{4}, \sec x = \frac{5}{3}, \cot x = -\frac{3}{4}$
2. Choose the best answer. Expressed in terms of $\sin x$ and $\cos x$ and simplified, $\tan x \csc x =$ (wherever the denominator $\neq 0$) 2. _____
- a. $\cos x$ b. $\cot x \sin x$
 c. $\sec x$ d. $\cot x$

For Exercises 3 and 4, $\sin s = \frac{2}{3}$, with s in quadrant II, and $\cos t = \frac{3}{5}$, with t in quadrant IV.

3. Find $\sin(s+t)$. 3. _____
- a. $-\frac{2}{3}$ b. $-\frac{2+\sqrt{5}}{5}$
 c. 1 d. $\frac{6+4\sqrt{5}}{15}$
4. Find $\tan 2s$. 4. _____
- a. $-4\sqrt{5}$ b. $-\frac{2\sqrt{5}}{5}$
 c. 0 d. $\frac{2+\sqrt{5}}{5}$
5. Suppose $x = \frac{7\pi}{12}$. Use a difference identity to find the exact value of $\cos x$. 5. _____
- a. $\frac{\sqrt{2}-\sqrt{6}}{4}$ b. $\frac{3\sqrt{2}-2}{12}$
 c. $-\frac{1}{6}$ d. $\frac{2+\sqrt{3}}{12}$

CHAPTER 7, FORM E, PAGE 2

6. Determine which of the following is true. 6. _____
- a. $\cos^2 x - \sin^2 x = 0$ b. $\tan^2 x = \sec^2 x - 1$
- c. $\tan x = \frac{\cos x}{\sin x}$ d. $\sec x = \frac{1}{\sin x}$
7. Determine which of the following is an identity. 7. _____
- a. $\frac{\cos 2\alpha}{\csc \alpha} = \sin \alpha(\cos^2 \alpha - 1)$
- b. $\frac{2 \tan \alpha}{1 - \tan^2 \alpha} = 1 - \sec 2\alpha$
- c. $\frac{1}{\sin \alpha + \tan \alpha} = \frac{\cot \alpha}{1 + \cos \alpha}$
- d. $\frac{\sin 2\alpha \cos \alpha}{\cot \alpha} = 2(1 - \sin^2 \alpha) \cot \alpha$
8. Determine which of the following is *not* an identity. 8. _____
- a. $\tan 2\alpha = \frac{2 \tan \alpha}{2 - \sec^2 \alpha}$
- b. $\frac{\csc \alpha + \tan \alpha}{\sec \alpha} \cot \alpha$
- c. $\tan \frac{\alpha}{2} \csc \alpha = \frac{1}{1 + \cos \alpha}$
- d. $\frac{\sec^2 \alpha - \tan^2 \alpha}{\cot \alpha} = \tan \alpha$
9. Which of the following expressions equals $\sin\left(\theta + \frac{\pi}{3}\right)$? 9. _____
- a. $\frac{1}{2} \sin \theta + \frac{\sqrt{3}}{2} \cos \theta$
- b. $\frac{\sqrt{2}}{2} \sin \theta + \frac{\sqrt{2}}{2} \cos \theta$
- c. $2 \sin \theta$
- d. $\cos(2\theta)$

CHAPTER 7, FORM E, PAGE 3

- 10.** State the domain (D) and range (R) of $\sec^{-1} x$. **10.** _____
- a.** D: $[-1, 1]$, R: $\left[-\frac{\pi}{2}, \frac{\pi}{2}\right]$
- b.** D: $[-1, 1]$, R: $(-\bullet, \bullet)$
- c.** D: $(-\bullet, \bullet)$, R: $[0,]$
- d.** D: $(-\infty, -1] \cup [1, \infty)$, R: $\left[0, \frac{\pi}{2}\right) \cup \left(\frac{\pi}{2}, \pi\right]$

- 11.** Give the degree measure of θ . $\theta = \sin^{-1}\left(-\frac{\sqrt{2}}{2}\right)$ **11.** _____
- a.** 45° **b.** 60°
- c.** -45° **d.** -30°

In Exercises 12 and 13, find each exact value.

- 12.** $\tan\left(\arctan\frac{2\sqrt{3}}{3}\right)$ **12.** _____
- a.** -1 **b.** $\frac{2\sqrt{3}}{3}$
- c.** $\frac{3}{2}$ **d.** $\sqrt{2}$

- 13.** $\sin\left[\arctan(-1) + \arcsin\left(-\frac{\sqrt{2}}{2}\right)\right]$ **13.** _____
- a.** $-\frac{1}{2}$ **b.** -1
- c.** $\sqrt{3}$ **d.** 1

- 14.** Give $\tan(\sin^{-1} u)$ as a non-trigonometric expression in u . **14.** _____
- a.** $\frac{u}{\sqrt{1-u^2}}$ **b.** $1+u^2$
- c.** $\frac{-1}{\sqrt{1-u^2}}$ **d.** $\frac{u^2}{1+u^2}$

In Exercises 15 and 16, solve each equation algebraically in the interval $[0^\circ, 360^\circ)$.
For Exercise 16, use a calculator and round the answer to three decimal places.

- 15.** $\cos 2\theta = \sin 2\theta - 1$ **15.** _____
- a.** $30^\circ, 60^\circ, 90^\circ, 120^\circ$ **b.** $45^\circ, 90^\circ, 225^\circ, 270^\circ$
- c.** $0^\circ, 90^\circ, 120^\circ$ **d.** $0^\circ, 45^\circ, 135^\circ$

CHAPTER 7, FORM E, PAGE 4

- 16.** $2 \tan \theta = 3 \sin \theta$
a. $0^\circ, 23.572^\circ, 156.428^\circ$
b. $23.607^\circ, 180^\circ, 203.607^\circ$
c. $90^\circ, 142.636^\circ, 322.636^\circ$
d. $0^\circ, 48.190^\circ, 180^\circ, 311.810^\circ$

16. _____

In Exercises 17 and 18, solve each equation algebraically in the interval $[0, 2\pi)$.

- 17.** $4 \cos^2 \theta - 3 = 0$
a. $0, \frac{2\pi}{3}, \frac{4\pi}{3}$ **b.** $\frac{\pi}{6}, \frac{5\pi}{6}, \frac{7\pi}{6}, \frac{11\pi}{6}$
c. $0, \frac{\pi}{3}, \frac{5\pi}{3}$ **d.** $\frac{\pi}{2}, \frac{2\pi}{3}, \frac{5\pi}{3}, \frac{7\pi}{6}$

17. _____

- 18.** $\cot \frac{x}{2} = \sin x$
a. 0 **b.** $\frac{\pi}{4}, \frac{3\pi}{4}$
c. $0, \frac{\pi}{2}$ **d.** $\frac{\pi}{2}, \pi, \frac{3\pi}{2}$

18. _____

In Exercises 19 and 20, solve the equation for x .

- 19.** $6y = 3 \sin(2x - 5)$
a. $x = \frac{\sin^{-1}(-6y)}{5}$ **b.** $x = \frac{2 - 2 \sin^{-1} y}{5}$
c. $x = \frac{5 - \sin y}{2}$ **d.** $x = \frac{5 + \sin^{-1} 2y}{2}$

19. _____

- 20.** $\tan^{-1} 2x = \frac{\pi}{3}$
a. $\frac{\pi}{3}$ **b.** -1
c. $\frac{\sqrt{3}}{2}$ **d.** 2

20. _____

CHAPTER 7, FORM F
COLLEGE ALGEBRA AND TRIGONOMETRY

NAME _____
 DATE _____

Choose the best answer.

1. Given $\sin x = -\frac{3\sqrt{10}}{10}$ and $180^\circ < x < 270^\circ$, find 1. _____

the remaining five trigonometric functions of x .

a. $\cos x = \frac{1}{3}$, $\tan x = 1$, $\csc x = \frac{3\sqrt{10}}{10}$, $\sec x = -\frac{\sqrt{10}}{10}$, $\cot x = -\frac{\sqrt{3}}{10}$

b. $\cos x = \frac{\sqrt{10}}{10}$, $\tan x = 3$, $\csc x = -\frac{\sqrt{10}}{3}$, $\sec x = \sqrt{10}$, $\cot x = \frac{1}{3}$

c. $\cos x = -\frac{\sqrt{10}}{10}$, $\tan x = 3$, $\csc x = -\frac{\sqrt{10}}{3}$, $\sec x = -\sqrt{10}$, $\cot x = \frac{1}{3}$

d. $\cos x = \frac{3\sqrt{10}}{10}$, $\tan x = -\frac{1}{3}$, $\csc x = \frac{\sqrt{10}}{3}$, $\sec x = -\frac{\sqrt{10}}{3}$, $\cot x = -3$

2. Choose the best answer. Expressed in terms of $\sin x$ and $\cos x$ and simplified, $\csc^2 x - \cot^2 x =$ (wherever the denominator $\neq 0$) 2. _____

a. $\tan x \sec x$ b. 0

c. $\frac{1 + \sin^2 x}{\cos^2 x}$ d. 1

For Exercises 3 and 4, $\cos s = -\frac{\sqrt{5}}{5}$, with s in quadrant II, and $\sin t = -\frac{4}{5}$, with t in quadrant III.

3. Find $\cos(s+t)$. 3. _____

a. $-\frac{2\sqrt{5}}{5}$ b. $1 - \frac{\sqrt{5}}{5}$

c. 1 d. $\frac{11\sqrt{5}}{25}$

4. Find $\sin \frac{t}{2}$. 4. _____

a. $\frac{2\sqrt{5}}{5}$ b. $-\frac{1}{5}$

c. $\frac{\sqrt{5}}{5}$ d. $\frac{11\sqrt{5}}{25}$

CHAPTER 7, FORM F, PAGE 2

5. Suppose $x = \frac{5\pi}{12}$. Use a difference identity to find the exact value of $\cos x$. 5. _____
- a. $\frac{\sqrt{6} + \sqrt{2}}{6}$ b. $\frac{\sqrt{6} - \sqrt{2}}{4}$
- c. $\frac{1}{3}$ d. $\frac{2 - \sqrt{3}}{4}$
6. Determine which of the following is true. 6. _____
- a. $\tan 105^\circ = \frac{\tan 50^\circ + \tan 55^\circ}{1 - \tan 50^\circ \tan 55^\circ}$
- b. $\sin 227^\circ = \sin 107^\circ \cos 120^\circ - \cos 107^\circ \csc 120^\circ$
- c. $\cos 85^\circ = \cos 120^\circ \cos 35^\circ - \sin 120^\circ \sin 35^\circ$
- d. None of these
7. Determine which of the following is an identity. 7. _____
- a. $\tan \frac{\alpha}{2} = \frac{\tan^2 \alpha}{2}$ b. $\cot \alpha \sin 2\alpha = 2 - 2\sin^2 \alpha$
- c. $\frac{\sin 2\alpha}{\cos \alpha} = \frac{2}{\sec \alpha}$ d. $\tan \frac{\alpha}{2} \sin \alpha = 1 - \cos^2 \alpha$
8. Determine which of the following is an identity. 8. _____
- a. $\frac{1 - \sin^2 \alpha}{\sin 2\alpha} = \cot \alpha$
- b. $\cot \alpha \sec \alpha = \frac{1}{\cos \alpha}$
- c. $\frac{1 + \tan^2 \alpha}{\tan^2 \alpha} = \frac{1}{1 - \cos^2 \alpha}$
- d. $\frac{\sec \alpha}{\tan \alpha + \cot \alpha} = -\cos \alpha$
9. Which of the following expressions equals $\cos(\pi - \theta)$? 9. _____
- a. $\frac{\sqrt{2}}{2} \sin \theta + \frac{\sqrt{2}}{2} \cos \theta$ b. $\frac{\sqrt{2}}{2} \sin \theta - \frac{\sqrt{2}}{2} \cos \theta$
- c. $\sin \theta$ d. $-\cos \theta$

CHAPTER 7, FORM F, PAGE 3

- 10.** State the domain (D) and range (R) of $\csc^{-1} x$. **10.** _____
- a.** D: $(-\infty, \infty)$, R: $\left[-\frac{\pi}{2}, \frac{\pi}{2}\right]$
- b.** D: $[-1, 1]$, R: $[-\frac{\pi}{2}, \frac{\pi}{2}]$
- c.** D: $[-1, 1]$, R: $(-\infty, \infty)$
- d.** D: $(-\infty, -1] \cup [1, \infty)$, R: $\left[-\frac{\pi}{2}, 0\right) \cup \left(0, \frac{\pi}{2}\right]$
- 11.** Give the degree measure of θ . $\theta = \cot^{-1}(-1)$ **11.** _____
- a.** 45° **b.** 60°
- c.** 135° **d.** 225°

In Exercises 12 and 13, find each exact value.

- 12.** $\cos^{-1}\left(\cot\frac{\pi}{4}\right)$ **12.** _____
- a.** 0 **b.** $\frac{1}{2}$
- c.** $\frac{\pi}{2}$ **d.** π
- 13.** $\tan\left[\arcsin\left(-\frac{1}{2}\right) + \arccos\left(-\frac{\sqrt{3}}{2}\right)\right]$ **13.** _____
- a.** $\sqrt{3}$ **b.** $-\frac{\sqrt{3}}{2}$
- c.** 1 **d.** $-\sqrt{3}$
- 14.** Give $\cos(\sin^{-1} u)$ as a non-trigonometric expression in u . **14.** _____
- a.** $\sqrt{1-u^2}$ **b.** $\frac{1}{\sqrt{1-u^2}}$
- c.** $1+u^2$ **d.** $\frac{-1}{1+u^2}$

In Exercises 15 and 16, solve each equation algebraically in the interval $[0^\circ, 360^\circ)$.
For Exercise 16, use a calculator and round the answer to three decimal places.

- 15.** $\tan^2 \theta - \tan \theta = 0$ **15.** _____
- a.** $0^\circ, 90^\circ$ **b.** $45^\circ, 135^\circ, 270^\circ$
- c.** $0^\circ, 90^\circ, 180^\circ, 225^\circ$ **d.** $0^\circ, 180^\circ$

CHAPTER 7, FORM F, PAGE 4

- 16.** $\cot^2 \theta + 3 \cot \theta = 1$
a. $106.873^\circ, 253.127^\circ$
b. $.333^\circ, -3.333^\circ$
c. $73.155^\circ, 163.155^\circ, 253.155^\circ, 343.155^\circ$
d. $0^\circ, 153.155^\circ, 206.845^\circ$

16. _____

In Exercises 17 and 18, solve each equation algebraically in the interval $[0, 2\pi)$.

17. $\tan \frac{x}{2} - \csc x = 0$

17. _____

- a.** $0, \frac{\pi}{2}$ **b.** $\frac{\pi}{4}, \frac{3\pi}{4}, \frac{7\pi}{4}$
c. $0, \frac{\pi}{3}, \frac{5\pi}{3}$ **d.** $\frac{\pi}{6}, \pi, \frac{7\pi}{6}$

18. $\cot^2 x - \cot x = 0$

18. _____

- a.** $0, \frac{\pi}{2}, \frac{3\pi}{4}$ **b.** $\frac{\pi}{4}, \frac{\pi}{2}, \frac{5\pi}{4}, \frac{3\pi}{2}$
c. $\frac{\pi}{4}, \frac{5\pi}{4}, \frac{7\pi}{4}$ **d.** $0, \pi$

In Exercises 19 and 20, solve the equation for x .

19. $y = -2 \tan(x + 6)$

19. _____

- a.** $x = -6 \tan^{-1}\left(\frac{y}{2}\right)$ **b.** $x = 2 \tan^{-1}\left(\frac{1}{y+6}\right)$
c. $x = -2 \tan^{-1}(6y)$ **d.** $x = -6 - \tan^{-1}\left(\frac{y}{2}\right)$

20. $-\arccos x + \arctan \frac{5}{12} = 0$

20. _____

- a.** $-\frac{5}{12}$ **b.** $\frac{12}{13}$
c. $\frac{7}{12}$ **d.** $-\frac{13}{12}$

CHAPTER 8, FORM A
COLLEGE ALGEBRA AND TRIGONOMETRY

NAME _____
 DATE _____

1. Given that $b = 30$ and $c = 42$ in a triangle ABC , which of the following is impossible?

- a. $a = 15$ b. $a = 29$
 c. $a = 63$ d. $a = 80$

1. _____

In Exercises 2 and 3, find the indicated part of each triangle ABC .

2. $B = 42.2^\circ$, $C = 108.7^\circ$, $b = 34.48$ m; find A .

2. _____

3. $C = 39^\circ 30'$, $c = 61.3$ ft, $b = 80.5$ ft; find B . Round to the nearest $10'$.

3. _____

4. Solve triangle ABC with $a = 28$ ft, $b = 34$ ft, and $c = 42$ ft. Round to the nearest $.1^\circ$.

4. _____

5. The sides of a triangular lot measure 260 ft, 190 ft, and 310 ft. Find the area of the lot.

5. _____

6. True or false: The resultant vector bisects the angle between the two component vectors.

6. _____

7. On a separate page, sketch the vector $\mathbf{a} + \mathbf{b}$.

7. See separate page.

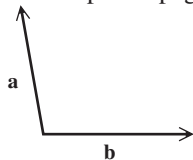

8. Find the magnitude and direction angle for $\mathbf{u} = \langle -18, 0 \rangle$, rounded to the nearest tenth.

8. _____

9. Write \mathbf{u} in the form $\langle a, b \rangle$ if $|\mathbf{u}| = 9$, and the direction angle of \mathbf{u} is 30° .

9. _____

10. A plane is heading due north with a ground speed of 405 mph. A 30 mph wind is blowing at a bearing of 48° . Find the plane's resulting speed.

10. _____

11. True or false: The product of two nonreal complex numbers can be a real number.

11. _____

In Exercises 12 and 13, perform the indicated operations. Write answers in standard form.

12. $\frac{8 - 4i}{5 + 3i}$

12. _____

13. $(3 \text{ cis } 30^\circ)^4$

13. _____

CHAPTER 8, FORM A, PAGE 2

14. Find all solutions of the equation $x^3 = -64$.

14. _____

15. Write $5 - 5i\sqrt{3}$ in trigonometric form.

15. _____

16. Find all square roots of $9i$. Express answers in standard form.

16. _____

17. Write an equivalent equation in rectangular coordinates for $r = 1 + 2 \sin \theta$.

17. _____

18. Write an equivalent equation in polar coordinates for $x^2 + y^2 = 25$.

18. _____

19. Graph: $r = 3 \sin \theta$, for θ in $[0, 360^\circ)$.

19.

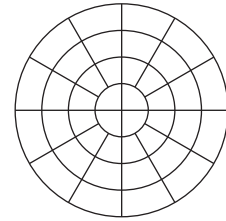

20. Graph: $x = t$, $y = t^2$, for t in $[-2, 2]$.

20.

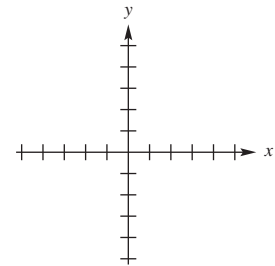

CHAPTER 8, FORM B
COLLEGE ALGEBRA AND TRIGONOMETRY

NAME _____
 DATE _____

1. Given that $a = 29$ and $b = 50$ in a triangle ABC , which of the following is impossible?
- a. $c = 18$ b. $c = 25$
 c. $c = 43$ d. $c = 69$

1. _____

In Exercises 2 and 3, find the indicated part of each triangle ABC .

2. $C = 32^\circ$, $B = 21^\circ 30'$, $c = 47.8$ ft; find b .
3. $B = 11.1^\circ$, $a = 21.31$ cm, $b = 12.31$ cm; find C . Round to the nearest $10'$.
4. Solve triangle ABC with $a = 32$ ft, $b = 49$ ft, and $c = 63$ ft.
5. The sides of a triangular lot measure 75 m, 85 m, and 110 m. Find the area of the lot.
6. True or false: According to the parallelogram rule, the resultant vector of \mathbf{A} and \mathbf{B} is the diagonal of the parallelogram that has \mathbf{A} and \mathbf{B} as two adjacent sides.
7. On a separate page, sketch the indicated vector $\mathbf{m} - \mathbf{n}$.

2. _____

3. _____

4. _____

5. _____

6. _____

7. See separate page.



8. Find the magnitude and direction angle for $\mathbf{u} = \langle -7, 8 \rangle$, rounded to the nearest tenth.
9. Write \mathbf{u} in the form $\langle a, b \rangle$ if $|\mathbf{u}| = 7.5$, and the direction angle of \mathbf{u} is 60° .
10. A plane is heading due north with a ground speed of 395 mph. A 45-mph wind is blowing at a bearing of 52° . Find the plane's resulting speed.
11. True or false: 2 is a complex number.

8. _____

9. _____

10. _____

11. _____

In Exercises 12 and 13, perform the indicated operations. Write answers in standard form.

12. $\frac{-2 + 5i}{3 + 1}$

12. _____

13. $(2 \operatorname{cis} 45^\circ)^4$

13. _____

14. Find all solutions of the equation $x^2 + 81 = 0$.

14. _____

15. Write $8\sqrt{3} + 8i$ in trigonometric form.

15. _____

CHAPTER 8, FORM B, PAGE 2

16. Find all complex fourth roots of -64 .
Express answers in trigonometric form.

16. _____

17. Write an equivalent equation in rectangular coordinates for $r = 4$.

17. _____

18. Write an equivalent equation in polar coordinates for $x = 8$.

18. _____

19. Graph: $r^2 = 4 \cos 2\theta$, for θ in $[0, 360^\circ)$.

19.

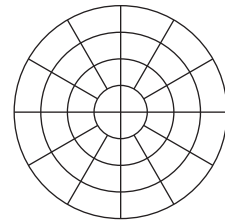

20. Graph: $x = t^2$, $y = t$, for t in $[-2, 2]$.

20.

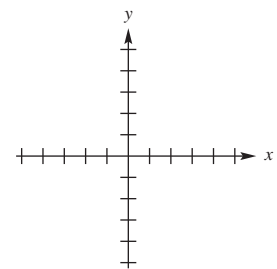

CHAPTER 8, FORM C
COLLEGE ALGEBRA AND TRIGONOMETRY

NAME _____
 DATE _____

1. Given that $a = 120$ and $c = 82$ in a triangle ABC , which of the following is impossible?

- a. $b = 40$ b. $b = 90$
 c. $b = 200$ d. $b = 250$

1. _____

In Exercises 2 and 3, find the indicated part of each triangle ABC .

2. $A = 39^\circ$, $C = 98^\circ 15'$, $a = 16.9$ cm; find c .
 3. $A = 65^\circ 30'$, $a = 42.9$ in., $b = 31.3$ in.; find B . Round to the nearest $10'$.
 4. Solve triangle ABC with $C = 68^\circ 20'$, $a = 19.2$ ft, and $b = 43.9$ ft. Round to the nearest $.1^\circ$.
 5. The sides of a triangular lot measure 36 yd, 92 yd, and 115 yd. Find the area of the lot.

2. _____

3. _____

4. _____

5. _____

6. True or false: Opposite sides of a parallelogram are congruent.

6. _____

7. On a separate page, sketch the vector $3\mathbf{m} + \mathbf{n}$.

7. See separate page.

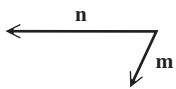

8. Find the magnitude and direction angle for $\mathbf{u} = \langle -3, -4 \rangle$, rounded to the nearest tenth.

8. _____

9. Write \mathbf{u} in the form $\langle a, b \rangle$ if $|\mathbf{u}| = 10.1$, and the direction angle of \mathbf{u} is 45° .

9. _____

10. A plane is heading due west with a ground speed of 508 mph. A 50-mph wind is blowing at a bearing of 76° . Find the plane's resulting speed.

10. _____

11. True or false: The sum of two nonreal complex numbers cannot be a real number.

11. _____

In Exercises 12 and 13, perform the indicated operations. Write answers in standard form.

12. $\frac{5 + 6i}{4 - i}$

12. _____

13. $\frac{3(\cos 120^\circ + i \sin 120^\circ)}{9(\cos 240^\circ + i \sin 240^\circ)}$

13. _____

14. Find all solutions of the equation $3x^2 = 2x - 1$.

14. _____

CHAPTER 8, FORM C, PAGE 2

15. Write $5(\cos 270^\circ + i \sin 270^\circ)$ in standard form.
16. Find all complex fourth roots of $625i$. Express answers in trigonometric form.
17. Write an equivalent equation in rectangular coordinates for $r = 4 \cos \theta$.
18. Write an equivalent equation in polar coordinates for $y = 3x - 4$.
19. Graph: $r = 4 \cos 2\theta$, for θ in $[0, 360^\circ)$.

15. _____

16. _____

17. _____

18. _____

19.

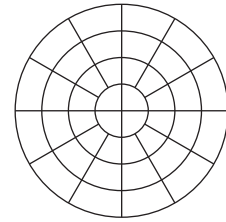

20. Show that the graph of $x = \frac{1}{2} \sin t$, $y = \frac{1}{2} \cos t$, for t in $[0, 2\pi)$, is a circle centered at the origin with radius $\frac{1}{2}$.

20. _____

CHAPTER 8, FORM D
COLLEGE ALGEBRA AND TRIGONOMETRY

NAME _____
 DATE _____

1. Given that $b = 63$ and $c = 92$ in a triangle ABC , which of the following is impossible?
- a. $a = 25$ b. $a = 35$
 c. $a = 45$ d. $a = 125$

1. _____

In Exercises 2 and 3, find the indicated part of each triangle ABC .

2. $B = 61^\circ$, $C = 82^\circ 45'$, $b = 45.9$ m; find c .
3. $C = 62^\circ 15'$, $c = 43.9$ in., $b = 40.3$ in.; find B . Round to the nearest $10'$.
4. Solve triangle ABC with $A = 23^\circ$, $a = 35$ cm, and $c = 45$ cm.
5. The sides of a triangular lot measure 75 ft, 85 ft, and 110 ft. Find the area of the lot.
6. True or false: If two vectors have the same magnitude, they are equal.
7. On a separate page, sketch the vector $\mathbf{b} - \mathbf{a}$.

2. _____

3. _____

4. _____

5. _____

6. _____

7. See separate page.

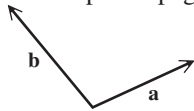

8. Find the magnitude and direction angle for $\mathbf{u} = \langle -12, 5 \rangle$, rounded to the nearest tenth.
9. Write \mathbf{u} in the form $\langle a, b \rangle$ if $|\mathbf{u}| = 12.0$, and the direction angle of \mathbf{u} is 45° .
10. A force of 52.7 pounds makes an angle of $53^\circ 15'$ with a force of 35.3 pounds. Find the angle made by the equilibrant with the 52.7-pound force.
11. True or false: The conjugate of $-2 + 3i$ is $2 - 3i$.

8. _____

9. _____

10. _____

11. _____

In Exercises 12 and 13, perform the indicated operations. Write answers in standard form.

12. $(-2 + i)^3$
13. $(2 \text{ cis } 45^\circ)^4$
14. Find all solutions of the equation $x^2 = -2x - 2$.
15. Write $-3\sqrt{3} + 3i$ in trigonometric form.

12. _____

13. _____

14. _____

15. _____

CHAPTER 8, FORM D, PAGE 2

16. Find all square roots of $25i$. Express answers in standard form.
17. Write an equivalent equation in rectangular coordinates for $r = 3 \cos \theta + 3 \sin \theta$.
18. Write an equivalent equation in polar coordinates for $x^2 + y^2 = 81$.
19. Graph: $r = 2 + 2 \cos \theta$, for θ in $[0, 360^\circ)$.

16. _____

17. _____

18. _____

19.

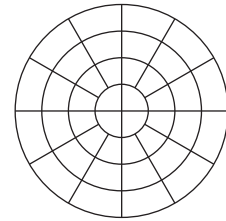

20. Graph: $x = \sqrt{t}$, $y = t$, for t in $[0, 4]$.

20.

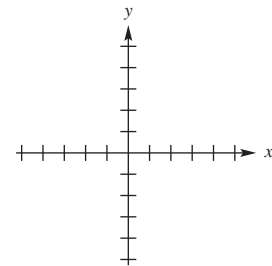

CHAPTER 8, FORM E
COLLEGE ALGEBRA AND TRIGONOMETRY

NAME _____
DATE _____

Choose the best answer.

1. Given that $b = 21$ and $c = 39$ in a triangle ABC , which of the following is impossible? 1. _____
- a. $a = 12$ b. $a = 20$
c. $a = 25$ d. $a = 57$

In Exercises 2 and 3, find the indicated part of each triangle ABC .

2. $A = 40^\circ$, $C = 72^\circ 45'$, $c = 23.2$ m; find a . 2. _____
- a. 11.8 m b. 12.3 m
c. 13.4 m d. 15.6 m
3. $B = 36^\circ 30'$, $a = 42.7$ ft, $b = 25.8$ ft; find all possible values of A . 3. _____
- a. no possible value b. $53^\circ 30'$
c. $58^\circ 32'$ and $121^\circ 28'$ d. $79^\circ 53'$ and $100^\circ 7'$
4. Solve triangle ABC with $a = 95$ ft, $b = 140$ ft, $c = 205$ ft. 4. _____
- a. $A: 66^\circ, B: 84^\circ, C: 30^\circ$ b. $A: 32^\circ, B: 52^\circ, C: 96^\circ$
c. $A: 24^\circ, B: 36^\circ, C: 120^\circ$ d. $A: 36^\circ, B: 50^\circ, C: 94^\circ$
5. The sides of a triangular lot measure 120 ft, 155 ft, and 242 ft. Find the area of the lot. 5. _____
- a. 4501 ft^2 b. 5498 ft^2
c. 7819 ft^2 d. 8017 ft^2
6. The angle between vector \mathbf{u} and vector \mathbf{v} measures 30° . What is the angle between vector \mathbf{u} and vector $\mathbf{u} + \mathbf{v}$? 6. _____
- a. 10° b. 15°
c. 20° d. Cannot be determined.

CHAPTER 8, FORM E, PAGE 2

7. Determine which sketch best represents $\mathbf{u} + \mathbf{v}$.

7. _____

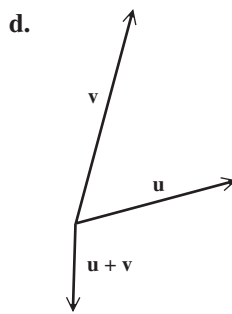
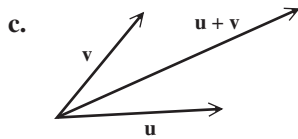
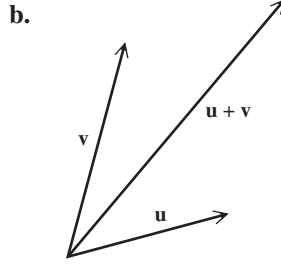
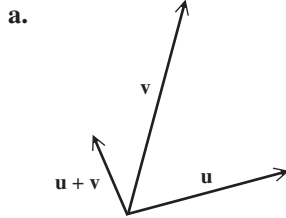
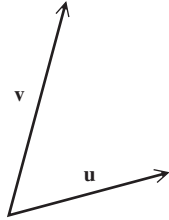

8. Find the magnitude and direction angle for $\mathbf{u} = \langle -5, 12 \rangle$, rounded to the nearest tenth.

8. _____

- a. 13, 112.6° b. 15, 112.6°
 c. 13, 157.4° d. 13, 67.4°

9. Write \mathbf{u} in the form $\langle a, b \rangle$ if $|\mathbf{u}| = 7$ and the direction angle of $\mathbf{u} = 135^\circ$.

9. _____

- a. $\left\langle \frac{7\sqrt{2}}{2}, \frac{7\sqrt{2}}{2} \right\rangle$ b. $\left\langle -\frac{7\sqrt{2}}{2}, -\frac{7\sqrt{2}}{2} \right\rangle$
 c. $\left\langle -\frac{\sqrt{2}}{2}, \frac{\sqrt{2}}{2} \right\rangle$ d. $\left\langle -\frac{7\sqrt{2}}{2}, \frac{7\sqrt{2}}{2} \right\rangle$

10. A force of 42.5 pounds makes an angle of $44^\circ 15'$ with a force of 23.8 pounds. Find the angle made by the equilibrant with the 42.5-pound force.

10. _____

- a. 15.6 b. 106.0°
 c. 164.4° d. 173.2°

CHAPTER 8, FORM E, PAGE 3

- 11.** Determine which of the following is true.
- a.** The product of two nonreal complex numbers is always a nonreal complex number.
 - b.** The product of two nonreal complex numbers is always real.
 - c.** The sum of two nonreal complex numbers is sometimes real.
 - d.** The sum of two nonreal complex numbers is never real.

11. _____

In Exercises 12 and 13, Perform the indicated operations. Write answers in standard form.

- 12.** $\frac{2-i}{5+3i}$
- a.** $\frac{1}{16} - \frac{13}{16}i$
 - c.** $\frac{7}{34} + \frac{11}{34}i$

- b.** $\frac{13}{16} + \frac{1}{16}i$
- d.** $\frac{7}{34} - \frac{11}{34}i$

12. _____

- 13.** $(3 \operatorname{cis} 135^\circ)^3$
- a.** $\frac{27\sqrt{2}}{2} - \frac{27i\sqrt{2}}{2}$
 - c.** -27

- b.** $\frac{27\sqrt{2}}{2} + \frac{27i\sqrt{2}}{2}$
- d.** $\frac{27\sqrt{2}}{2} - \frac{i\sqrt{2}}{2}$

13. _____

- 14.** Find all solutions of the equation $x^2 = -1 + 2i\sqrt{2}$.
- a.** $2 \pm i\sqrt{2}$
 - c.** $-1 \pm i\sqrt{2}$

- b.** $1 \pm i\sqrt{2}$
- d.** $-1 - i\sqrt{2}, 1 + i\sqrt{2}$

14. _____

- 15.** Write $-\sqrt{7} - i\sqrt{7}$ in trigonometric form.

- a.** $(\cos 30^\circ + i \sin 30^\circ)$
- b.** $7(\cos 60^\circ + i \sin 60^\circ)$
- c.** $14(\cos 210^\circ + i \sin 210^\circ)$
- d.** $\sqrt{14}(\cos 225^\circ + i \sin 225^\circ)$

15. _____

- 16.** Find all square roots of $36i$.

- a.** $3 \pm 3i\sqrt{2}$
- c.** $-3\sqrt{2} \pm 3i\sqrt{2}$
- b.** $3 + 3i\sqrt{2}$
- d.** $3 + 3i\sqrt{2}, -3\sqrt{2} - 3i\sqrt{2}, 3\sqrt{2} + 3i\sqrt{2}$

16. _____

- 17.** Write an equivalent equation in rectangular coordinates for $r \sin \theta = 10$.

- a.** $x^2 + (y-1)^2 = 2$
- c.** $y = 10$
- b.** $y = \frac{x}{2}$
- d.** None of these

17. _____

CHAPTER 8, FORM E, PAGE 4

18. Write an equivalent equation in polar coordinates for $x = 2$.

- a. $\theta = 2\pi$ b. $r = 2$
 c. $r = 2 \sin \theta$ d. $r = \frac{2}{\cos \theta}$

18. _____

19. Determine which of the following is the graph of $r = \frac{2}{1 - \sin \theta}$.

19. _____

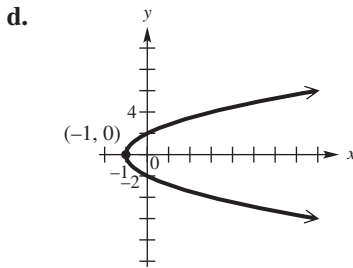
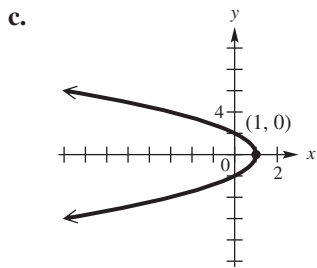
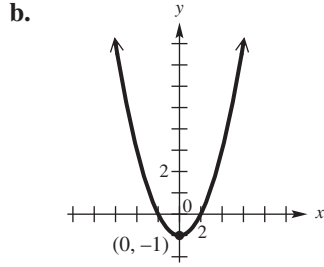
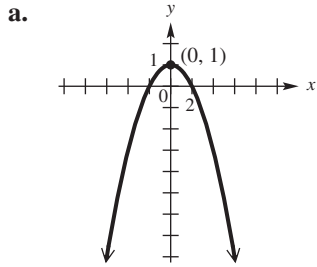

20. Graph: $x = 2t - 1$, $y = t^2$, for t in $[-2, 2]$.

20. _____

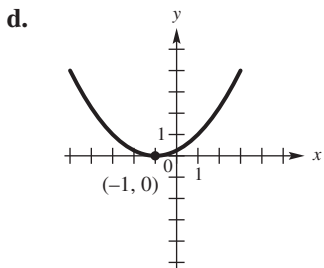
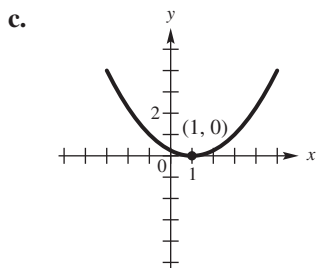
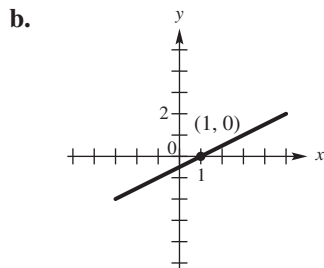
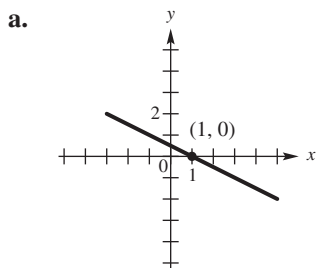

CHAPTER 8, FORM F
COLLEGE ALGEBRA AND TRIGONOMETRY

NAME _____
DATE _____

Choose the best answer.

1. Given that $a = 19$ and $c = 42$ in a triangle ABC , which of the following is impossible? 1. _____
- a. $b = 22$ b. $b = 28$
c. $b = 35$ d. $b = 59$

In Exercises 2 and 3, find the indicated part of each triangle ABC .

2. $B = 35^\circ$, $C = 82^\circ 15'$, $b = 17.2$ cm; find c . 2. _____
- a. 12.3 cm b. 24.5 cm
c. 29.7 cm d. 33.8 cm

3. $C = 42^\circ 10'$, $a = 15.3$ ft, $c = 23.4$ ft; find A . 3. _____
- a. $13^\circ 08'$ b. $26^\circ 02'$
c. $40^\circ 32'$ d. $59^\circ 43'$

4. Solve triangle ABC with $a = 32$ m, $b = 47$ m, $c = 68$ m. 4. _____
- a. $A: 22^\circ$, $B: 45^\circ$, $C: 113^\circ$
b. $A: 65^\circ$, $B: 52^\circ$, $C: 63^\circ$
c. $A: 19^\circ$, $B: 72^\circ$, $C: 89^\circ$
d. $A: 25^\circ$, $B: 38^\circ$, $C: 117^\circ$

5. The sides of a triangular lot measure 85 m, 105 m, and 162 m. Find the area of the lot. 5. _____
- a. 3214 ft^2 b. 3990 ft^2
c. 4322 ft^2 d. 5323 ft^2

6. The magnitudes of vector \mathbf{u} and vector \mathbf{v} both equal 5. Which of the following is *always* true? 6. _____
- a. $|\mathbf{u} + \mathbf{v}| = 5$ b. $|\mathbf{u} + \mathbf{v}| = 0$
c. $\theta = 0^\circ$ d. None of these

CHAPTER 8, FORM F, PAGE 2

7. Determine which sketch best represents $\mathbf{u} + \mathbf{v}$.

7. _____

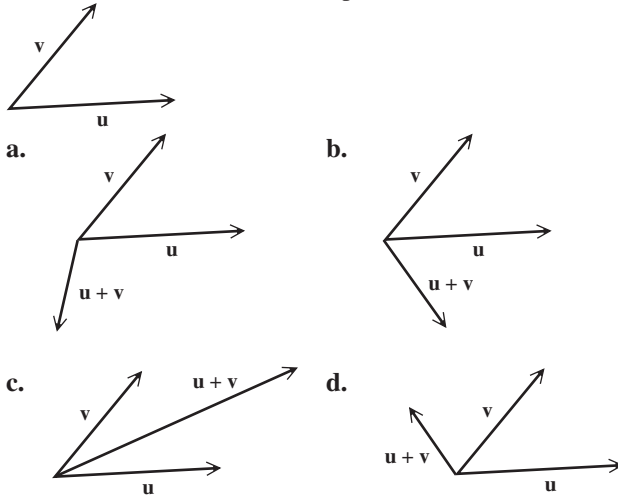

8. Find the magnitude and direction angle for $\mathbf{u} = \langle -5\sqrt{3}, 5 \rangle$.

8. _____

- a. 10, 150° b. 10, 330°
 c. 20, 30° d. 20, 150°

9. Write \mathbf{u} in the form $\langle a, b \rangle$ if $|\mathbf{u}| = 5$ and the direction angle of \mathbf{u} is 120° .

9. _____

- a. $\left\langle \frac{5}{2}, \frac{5\sqrt{3}}{2} \right\rangle$ b. $\left\langle \frac{\sqrt{3}}{2}, \frac{1}{2} \right\rangle$
 c. $\left\langle -\frac{5}{2}, \frac{5\sqrt{3}}{2} \right\rangle$ d. $\left\langle -\frac{5\sqrt{3}}{2}, \frac{5}{2} \right\rangle$

10. A plane is heading due east with a ground speed of 398 mph. A 50 mph wind is blowing at a bearing of 48° . Find the plane's resulting speed.

10. _____

- a. 412 mph b. 436 mph
 c. 444 mph d. 458 mph

11. Determine which of the following is *not* true.

11. _____

- a. -5 is a complex number.
 b. The product of two real numbers is sometimes a nonreal complex number.
 c. The sum of two nonreal complex numbers is sometimes real.
 d. The product of two nonreal complex numbers is sometimes real.

CHAPTER 8, FORM F, PAGE 3

In Exercises 12 and 13, perform the indicated operations. Write answers in the standard form.

12. $\frac{3+4i}{5-2i}$ 12. _____
- a. $\frac{7}{12} - \frac{4}{12}i$ b. $\frac{1}{10} + \frac{7}{10}i$
- c. $\frac{7}{29} + \frac{26}{29}i$ d. $\frac{7}{29} - \frac{26}{29}i$
-
13. $(4 \operatorname{cis} 60^\circ)^3$ 13. _____
- a. $8 + 24i\sqrt{3}$ b. $-8 - 24i\sqrt{3}$
- c. -64 d. 64
-
14. Find all solutions to the equation $x^3 - 8 = 0$. 14. _____
- a. $-2\sqrt{2}, 0, 2\sqrt{2}$ b. 2
- c. $-2, 1 \pm i\sqrt{3}$ d. $2, -1 \pm i\sqrt{3}$
-
15. Write $5\sqrt{3} - 5i$ in trigonometric form. 15. _____
- a. $10(\cos 120^\circ + i \sin 120^\circ)$
- b. $10(\cos 330^\circ + i \sin 330^\circ)$
- c. $10(\cos 450^\circ + i \sin 450^\circ)$
- d. $5\sqrt{2}(\cos 270^\circ + i \sin 270^\circ)$
-
16. Find all square roots of $18i$. 16. _____
- a. $\pm 3i$ b. $-3 \pm 3i\sqrt{2}$
- c. $-3 - 3i, 3 + 3i$ d. $3 + 3i$
-
17. Write an equivalent equation in rectangular coordinates for $r = 2\cos \theta - 4\sin \theta$. 17. _____
- a. $x^2 + (y-2)^2 = 9$ b. $(x-1)^2 + (y+2)^2 = 5$
- c. $y = \frac{x}{2}$ d. None of these
-
18. Write an equivalent equation in polar coordinates for $x = 3y^2$. 18. _____
- a. $\theta = 3$ b. $r = 3\theta$
- c. $r = \frac{\cot \theta \csc \theta}{3}$ d. $r = 3 \cos \theta$

CHAPTER 8, FORM F, PAGE 4

19. Determine which of the following is the graph of $r = \frac{3}{1 + \cos \theta}$.

19. _____

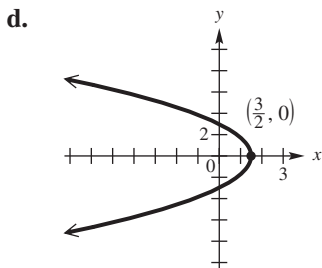
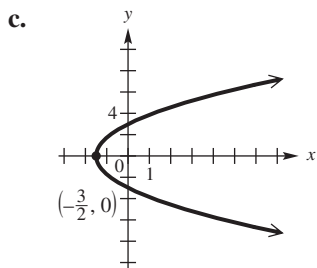
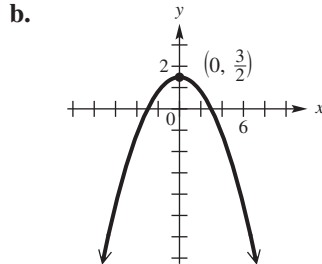
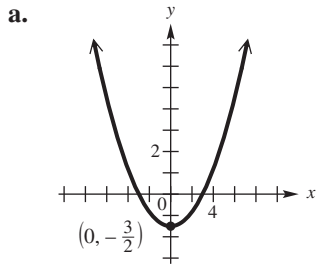

20. Graph: $x = 3t + 3$, $y = (t + 1)^2$, for t in $[-2, 2]$.

20. _____

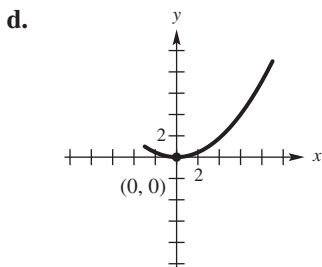
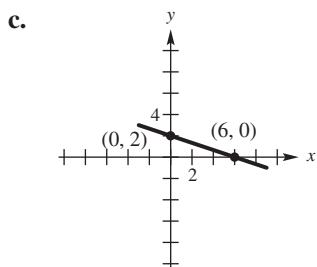
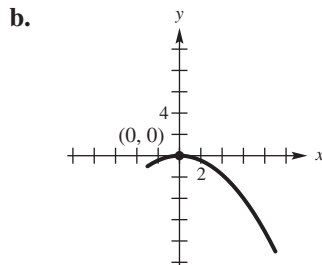
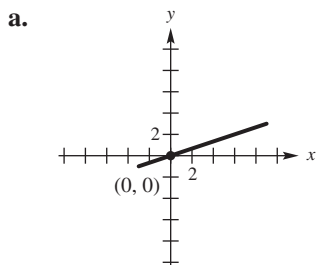

CHAPTER 9, FORM A
COLLEGE ALGEBRA AND TRIGONOMETRY

NAME _____
 DATE _____

Use substitution or elimination to solve each system. Identify any system that is inconsistent or has infinitely many solutions. If a system has dependent equations, express the solution with y arbitrary.

1. $x + 2y = -1$ 1. _____
 $2x - 3y = 12$

2. $\frac{3}{4}x - \frac{2}{3}y = 1$ 2. _____
 $-\frac{3}{2}x + \frac{4}{3}y = 3$

3. $x + 2y - z = -1$ 3. _____
 $2x - y + z = 9$
 $x + 3y + 3z = 6$

Use the Gauss-Jordan method to solve each system.

4. $10m - 3n = 5$ 4. _____
 $5m + 2n = -8$

5. $x + 2y + z = -2$ 5. _____
 $2x + y - z = 1$
 $x + y - 2z = -3$

6. Find the equation that defines the parabola shown on the screen, using the information given at the bottom of the screen and in the table.

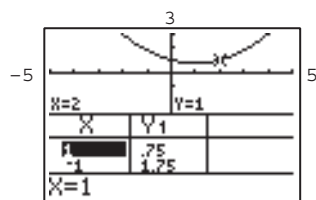

Evaluate each determinant.

7. $\begin{vmatrix} 5 & 2 \\ 6 & -5 \end{vmatrix}$ 7. _____

8. $\begin{vmatrix} 3 & 1 & -2 \\ 4 & 2 & 5 \\ -6 & 3 & -1 \end{vmatrix}$ 8. _____

CHAPTER 9, FORM A

Solve each system by Cramer's rule.

9. $4x + 2y = -2$
 $3x - y = 6$

9. _____

10. $2x - y + 2z = 3$
 $x - y + z = 2$
 $x + y + 2z = 3$

10. _____

11. Find the partial fraction decomposition of
 $\frac{4x^2 - 5x - 15}{x^3 - 4x^2 - 5x}$.

11. _____

Solve each nonlinear system of equations.

12. $x^2 - y^2 = 4$
 $x^2 + y^2 = 6$

12. _____

13. $x + 3y = 12$
 $xy = 9$

13. _____

14. If a system of two nonlinear equations contains one equation whose graph is a circle and another equation whose graph is a parabola, can the system have exactly one solution? If so, draw a sketch to indicate this situation.

14. _____

15. Find two numbers such that their sum is 72 and their difference is 38.

15. _____

16. Graph the solution set of
 $2x - 3y \leq 6$
 $x - y \geq 0$
 $0 \leq x \leq 4$
 $y \geq 0$.

16. _____

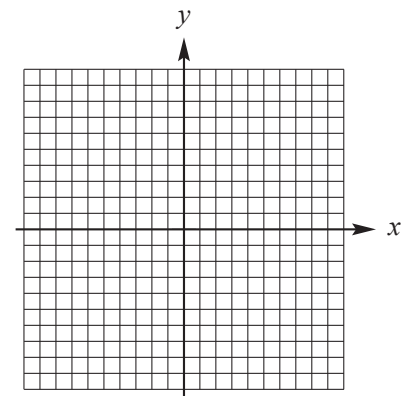

CHAPTER 9, FORM A

- 17.** *Use linear programming to solve the problem.*
 A company produces two models of lamps, *A* and *B*. They can produce up to 1500 lamps each day using a total of 60 hr of labor. It takes 3 min of labor to make one model *A* lamp and 2 min of labor to make one model *B* lamp. Graph the feasibility region and label the vertices.
 How many of each model should be made daily in order to maximize the company's profit if the profit on a model *A* lamp is \$4 and the profit on a model *B* lamp is \$3?

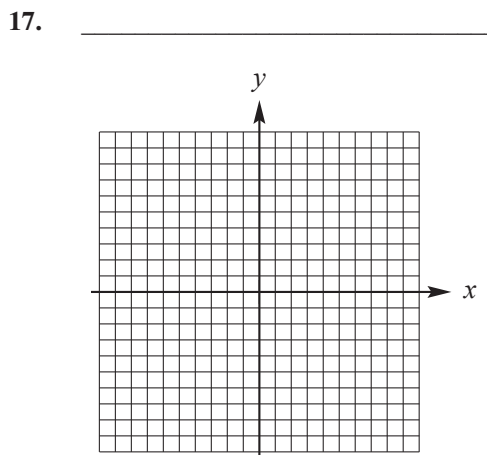

- 18.** Find the value of each variable in the equation $[x - 3 \quad y + 5 \quad z - 2] = [4x \quad 2 \quad 5z + 2]$.

18. _____

Perform each operation, whenever possible.

19.
$$\begin{bmatrix} 2 & 1 & 3 \\ 1 & 2 & -1 \\ 0 & 1 & 0 \end{bmatrix} \begin{bmatrix} 1 & 2 & 3 \\ 2 & -2 & 1 \\ 0 & 0 & 1 \end{bmatrix}$$

19. _____

20.
$$\begin{bmatrix} 1 & -8 & 10 \\ 5 & 2 & -3 \\ -4 & 0 & 0 \end{bmatrix} + \begin{bmatrix} -1 & 9 & 12 \\ 8 & 6 & 7 \\ -3 & 4 & 5 \end{bmatrix} + \begin{bmatrix} 0 & 2 & -1 \\ 5 & 6 & 3 \\ -7 & 11 & 2 \end{bmatrix}$$

20. _____

21.
$$5 \begin{bmatrix} 3 & 1 & -2 \\ -4 & 3 & -2 \end{bmatrix} + 3 \begin{bmatrix} 1 & -2 & 2 \\ -5 & -5 & 3 \end{bmatrix}$$

21. _____

- 22.** If *A* is a 4×1 matrix and *B* is a 1×4 matrix, find the size of the product *AB* and the product *BA*, if these products can be found.

22. _____

Find the inverse, if it exists, of each matrix.

23.
$$\begin{bmatrix} 2 & -4 \\ 4 & -7 \end{bmatrix}$$

23. _____

CHAPTER 9, FORM A

24.
$$\begin{bmatrix} 1 & 1 & 0 \\ 0 & 0 & 3 \\ 0 & 2 & 1 \end{bmatrix}$$

24. _____

25. Use the matrix inverse method to solve the system
$$4x - 3y = -14$$
$$6x + 5y = 17.$$

25. _____

CHAPTER 9, FORM B
COLLEGE ALGEBRA AND TRIGONOMETRY

NAME _____
 DATE _____

Use substitution or elimination to solve each system. Identify any system that is inconsistent or has infinitely many solutions. If a system has dependent equations, express the solution with y arbitrary.

1. $x - 3y = 4$
 $-2x + 6y = 2$

1. _____

2. $\frac{2}{3}x - y = 2$
 $x + \frac{1}{2}y = 7$

2. _____

3. $3x + y - 2z = -1$
 $2x - 3y + z = 4$
 $4x + 5y - z = -2$

3. _____

Use the Gauss-Jordan method to solve each system.

4. $4a + 3b = 1$
 $-3a - 5b = -20$

4. _____

5. $2x + 4y - 10z = -2$
 $3x + 9y - 21z = 0$
 $x + 5y - 12z = 1$

5. _____

6. Find the equation that defines the parabola shown on the screen, using the information given at the bottom of the screen and in the table.

6. _____

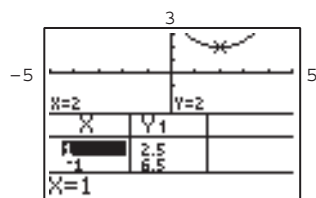

Evaluate each determinant.

7. $\begin{vmatrix} 4 & -4 \\ -1 & 5 \end{vmatrix}$

7. _____

8. $\begin{vmatrix} 2 & -3 & 5 \\ -4 & 1 & 3 \\ 3 & 2 & -1 \end{vmatrix}$

8. _____

CHAPTER 9, FORM B

Solve each system by Cramer's rule.

9. $2x + 2y = 1$
 $4x - 3y = -5$

9. _____

10. $x - y + z = 3$
 $2x + y + z = 6$
 $2x - 2y + z = 3$

10. _____

11. Find the partial fraction decomposition of
 $\frac{2x^2 + 7x + 9}{x^2 + 2x + 1}$.

11. _____

Solve each nonlinear system of equations.

12. $x + y = 1$
 $x^2 - y = -1$

12. _____

13. $x^2 + 3y^2 = 3$
 $x^2 - y^2 = 1$

13. _____

14. If a nonlinear system of two equations contains one equation whose graph is a parabola and another equation whose graph is a circle, can the system have exactly one solution? If so, draw a sketch to indicate this situation.

14. _____

15. Find two numbers such that their sum is 15 and the difference of their squares is 15.

15. _____

16. Graph the solution set of
 $2x - 3y \geq 6$
 $x + 5y \geq 5$.

16. _____

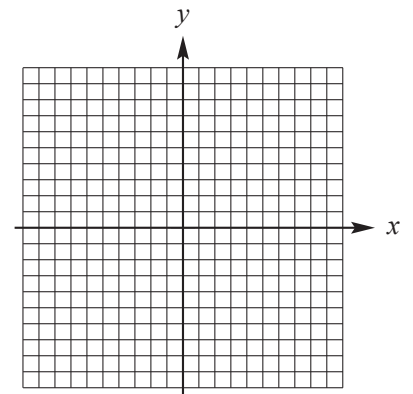

CHAPTER 9, FORM B

- 17.** *Use linear programming to solve the problem.*
 The Acme Glass Ring Company designs and sells two types of rings: the VIP and the SST. They can produce up to 24 rings each day using up to 60 total man-hours of labor. It takes 3 man-hours to make one VIP ring, and 2 man-hours to make one SST ring. Graph the feasibility region and label the vertices.
 How many of each type of ring should be made daily in order to maximize the company's profit, if the profit on a VIP ring is \$40 and the profit on an SST ring is \$35?

17. _____

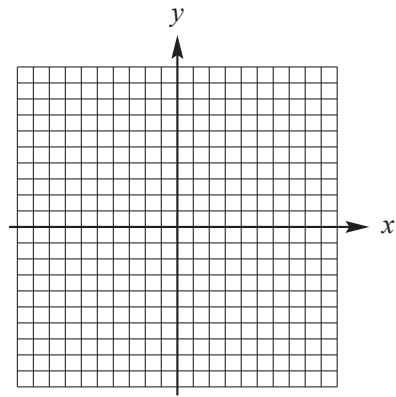

- 18.** Find the value of each variable in the equation

$$\begin{bmatrix} 5 & x-7 \\ y+2 & z+4 \end{bmatrix} = \begin{bmatrix} 5 & 10 \\ 2y & 3z \end{bmatrix}.$$

18. _____

Perform each operation, whenever possible.

19.
$$\begin{bmatrix} 3 & 2 & 5 \\ 1 & 3 & 2 \\ 4 & 2 & 1 \end{bmatrix} \begin{bmatrix} 2 \\ 0 \\ 4 \end{bmatrix}$$

19. _____

20.
$$\begin{bmatrix} 2 & 0 \\ -6 & 5 \end{bmatrix} + \begin{bmatrix} 1 & -3 \\ 7 & -2 \end{bmatrix} - 4 \begin{bmatrix} 8 & -3 \\ -5 & 4 \end{bmatrix}$$

20. _____

21.
$$\begin{bmatrix} 2 & 4 & 8 \\ -7 & 9 & -5 \end{bmatrix} + \begin{bmatrix} 4 & -5 \\ 6 & 0 \\ 4 & -3 \end{bmatrix}$$

21. _____

- 22.** If A is a 3×4 matrix and B is a 5×3 matrix, find the size of the product AB and the product BA , if these products can be found.

22. _____

Find the inverse, if it exists, of each matrix.

23.
$$\begin{bmatrix} 3 & -2 \\ 12 & -8 \end{bmatrix}$$

23. _____

CHAPTER 9, FORM B

24.
$$\begin{bmatrix} 1 & 2 & 0 \\ 0 & 4 & 2 \\ 1 & -1 & -2 \end{bmatrix}$$

24. _____

25. Use the matrix inverse method to solve the system
$$3x + y = 7$$
$$2x - 5y = -1.$$

25. _____

CHAPTER 9, FORM D
COLLEGE ALGEBRA AND TRIGONOMETRY

NAME _____
 DATE _____

Use substitution or elimination to solve each system. Identify any system that is inconsistent or has infinitely many solutions. If a system has dependent equations, express the solution with y arbitrary.

1. $4x + 5y = 13$
 $3x + y = -4$

1. _____

2. $\frac{1}{2}x + \frac{1}{3}y = \frac{1}{6}$
 $\frac{1}{4}x - \frac{1}{3}y = -\frac{1}{12}$

2. _____

3. $2x - y - z = 8$
 $2x - 3y - 4z = 6$
 $x + y - z = 0$

3. _____

Use the Gauss-Jordan method to solve each system.

4. $4r - 8s = 20$
 $-r + 3s = -7$

4. _____

5. $3x - 3y + 6z = -3$
 $2x + y + 2z = 4$
 $2x - 2y + 5z = -2$

5. _____

6. Find the equation that defines the parabola shown on the screen, using the information given at the bottom of the screen and in the table.

6. _____

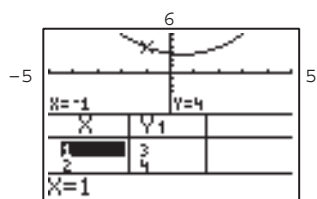

Evaluate each determinant.

7. $\begin{vmatrix} 7 & -10 \\ 3 & 5 \end{vmatrix}$

7. _____

8. $\begin{vmatrix} 0 & 4 & -3 \\ 2 & -0 & 4 \\ -5 & 1 & 0 \end{vmatrix}$

8. _____

CHAPTER 9, FORM D

Solve each system by Cramer's rule.

9. $3x + 4y = -5$ 9. _____
 $-7x + 8y = 11$

10. $x - 2y - 3z = -1$ 10. _____
 $2x + y + z = 6$
 $x + 3y - 2z = 13$

11. Find the partial fraction decomposition of 11. _____
 $\frac{9x^2 - 3x + 8}{x^3 + 2x}$.

Solve each nonlinear system of equations.

12. $2x^2 - 3y^2 = 6$ 12. _____
 $3x^2 + 2y^2 = 35$

13. $4x^2 + y^2 = 4$ 13. _____
 $2x - y = 0$

14. If a nonlinear system of two equations contains one equation whose graph is a line and another equation whose graph is a parabola, can the system have exactly two solutions? If so, draw a sketch to indicate this situation. 14. _____

15. Find two numbers such that their sum is 2 and the sum of their squares is 52. 15. _____

16. Graph the solution set of 16.
 $x^2 \leq y$
 $x \leq 0$
 $y \leq x + 2$.

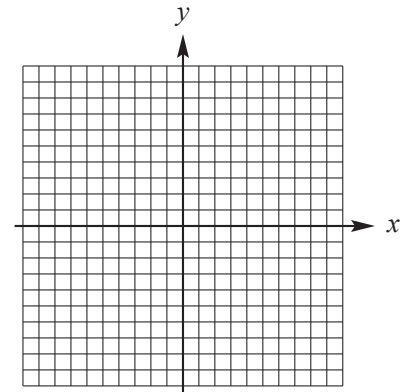

CHAPTER 9, FORM D

- 17.** Use linear programming to solve the problem.
 A company produces two types of desks, kneehole and rolltop. They can produce up to 25 desks each week using a total of 300 hr of labor. It takes 10 hr of labor to produce a kneehole desk and 15 hr of labor to produce a rolltop desk. Graph the feasibility region and label the vertices.
 How many desks of each type should be made weekly to maximize the company's profit if the profit on a kneehole desk is \$15 and the profit on a rolltop desk is \$20?

17. _____

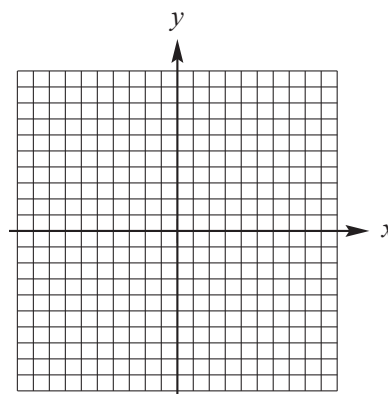

- 18.** Find $a, b, c,$ and d so that

$$\begin{bmatrix} 1 & 4 \\ 0 & 1 \end{bmatrix} \begin{bmatrix} a & b \\ c & d \end{bmatrix} = \begin{bmatrix} 1 & 0 \\ 0 & 1 \end{bmatrix}$$

18. _____

Perform each operation, whenever possible.

19. $\begin{bmatrix} 1 & -3 & 2 \\ 4 & 0 & 5 \\ -6 & 1 & -2 \end{bmatrix} \begin{bmatrix} 3 & 2 & 1 \\ 0 & -1 & 6 \\ 5 & 4 & 1 \end{bmatrix}$

19. _____

20. $\begin{bmatrix} 3 & 2 & 0 \\ -1 & 4 & -6 \end{bmatrix} \begin{bmatrix} 1 & 2 & -4 \\ 0 & -2 & 3 \\ 5 & 0 & 3 \end{bmatrix}$

20. _____

21. $2 \begin{bmatrix} 3 & 1 \\ -2 & 4 \\ 0 & 3 \\ 2 & 8 \end{bmatrix} + \begin{bmatrix} 1 & 4 \\ 3 & 6 \\ -3 & 7 \\ 3 & -2 \end{bmatrix}$

21. _____

- 22.** If A is a 3×2 matrix and B is a 2×4 matrix, find the size of the product AB and the product BA , if these products can be found.

22. _____

Find the inverse, if it exists, of each matrix.

23. $\begin{bmatrix} 3 & 9 \\ 2 & 6 \end{bmatrix}$

23. _____

CHAPTER 9, FORM D

24.
$$\begin{bmatrix} 1 & -1 & 1 \\ 1 & 2 & 0 \\ 2 & 2 & 1 \end{bmatrix}$$

24. _____

25. Use the matrix inverse method to solve the system
$$2x - 4y = 3$$
$$x + 3y = 1.$$

25. _____

CHAPTER 9, FORM E
COLLEGE ALGEBRA AND TRIGONOMETRY

NAME _____
 DATE _____

Choose the best answer.

Use substitution or elimination to solve each system. Identify any system that is inconsistent or has infinitely many solutions. If a system has dependent equations, express the solution with y arbitrary.

1. $x + 2y = 14$ 1. _____
 $2x + 2y = 10$

- a. $\{(-3, 4)\}$ b. $\{(-4, 9)\}$
 c. $\{(4, 8)\}$ d. \emptyset ; inconsistent

2. $\frac{7}{3}x + \frac{5}{4}y = 4$ 2. _____
 $\frac{5}{6}x - 2y = 21$

- a. $\{(-6, 8)\}$ b. $\{(6, 8)\}$
 c. $\{(-6, -8)\}$ d. $\{(6, -8)\}$

3. $2x - 3y - z = 2$ 3. _____
 $x - 4y + z = 2$
 $x + y - 3z = 1$

- a. $\{(-2, -3, -2)\}$ b. $\{(1, 2, 9)\}$
 c. $\{(-1, -1, -1)\}$ d. $\{(2, 3, -7)\}$

Use the Gauss-Jordan method to solve each system. Give the x -value of the solution only.

4. $5x - y = 28$ 4. _____
 $4x + 2y = 28$

- a. 6 b. 4 c. -4 d. 2

5. $-x + y + z = -3$ 5. _____
 $3x + z = 1$
 $-y - 2z = 4$

- a. -1 b. 4 c. -2 d. 1

CHAPTER 9, FORM E

6. Find the equation that defines the parabola shown on the screen, using the information given at the bottom of the screen and in the table.

6. _____

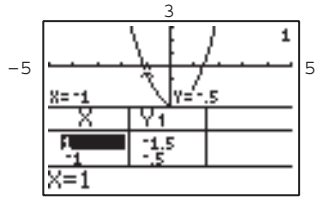

- a. $y = x^2 - .5x - 3$ b. $y = 2x^2 - x - 2$
 c. $y = 2x^2 - .5x - 3$ d. $y = x^2 - x + 2$

Evaluate each determinant.

7. $\begin{vmatrix} -7 & -3 \\ 4 & 11 \end{vmatrix}$

7. _____

- a. -89 b. 89 c. 56 d. -56

8. $\begin{vmatrix} 7 & -9 & 7 \\ 0 & 2 & 9 \\ 0 & 0 & -6 \end{vmatrix}$

8. _____

- a. -165 b. -84 c. 84 d. 165

9. Use Cramer's rule to find the y-value of the solution to the system

9. _____

$$-2x + 3y = 9$$

$$4x + 4y = 25$$

- a. $\frac{11}{17}$ b. $\frac{3}{5}$ c. $\frac{39}{20}$ d. $\frac{43}{10}$

10. Use Cramer's rule to find the x-value of the solution of the system

10. _____

$$3x - 6y - z = -43$$

$$x + 7y - 5z = 53$$

$$9x + y + z = 27$$

- a. 2 b. 3 c. 6 d. 8

CHAPTER 9, FORM E

11. Find the partial fraction decomposition of $\frac{4x^2 - 3x + 8}{x^3 - x^2 + 4x}$. 11. _____

a. $\frac{2}{x} + \frac{2x-1}{x^2-x+4}$

b. $\frac{1}{x} + \frac{-2}{x^2} + \frac{2}{x+4}$

c. $\frac{2}{x} + \frac{-2x+1}{x^2-x+4}$

d. $\frac{2}{x} + \frac{-1}{x-2} + \frac{1}{(x-2)^2}$

Solve each nonlinear system of equations.

12. $xy = 12$ 12. _____
 $2x - y = 5$

a. $\{(4, 3)\}$

b. $\left\{(4, 3), \left(-\frac{3}{2}, -8\right)\right\}$

c. $\{(4, 3), (-4, -3)\}$

d. \emptyset

13. $x^2 - y^2 = 39$ 13. _____
 $x - y = 3$

a. $\{(-8, -5)\}$

b. $\{(8, -5)\}$

c. $\{(-8, 5)\}$

d. $\{(8, 5)\}$

14. A nonlinear system of two equations contains one equation whose graph is a circle and another equation whose graph is a line. What is the greatest possible number of points of intersection for these two graphs? 14. _____

- a. 1 b. 2 c. 3 d. 4

15. Find two numbers such that their sum is 1 and the sum of their squares is 145. 15. _____

- a. 9 and -8 b. 9 and 8 c. 81 and 64 d. 81 and -64

CHAPTER 9, FORM E

16. Graph the solution set of $x^2 + y^2 < 9$
 $x > 2y - 2$.

16. _____

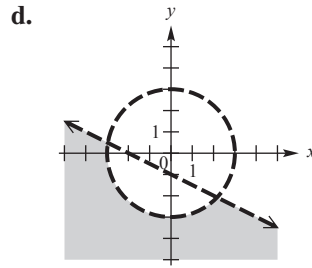
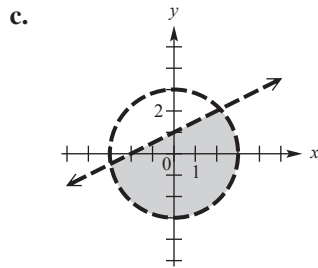
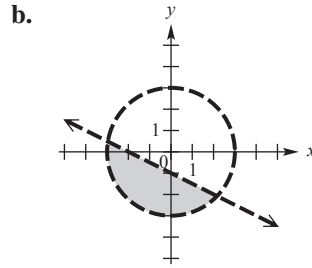
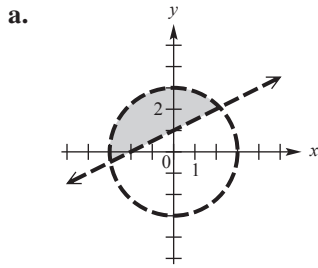

17. Use linear programming to solve the problem.
 A company produces widgets and gadgets, both of which require time on two machines, *A* and *B*. Manufacturing 100 widgets requires 1 hr on machine *A* and 2 hr on machine *B*. Manufacturing 100 gadgets requires 3 hr on machine *A* and 2 hr on machine *B*. Each machine is operated at most 18 hr per day. If 100 widgets produce \$30 profit and 100 gadgets produce \$20 profit, how many widgets and gadgets will produce a maximum profit each day?

17. _____

- a. 450 widgets and 450 gadgets
- b. No widgets and 600 gadgets
- c. 900 widgets and no gadgets
- d. 900 widgets and 600 gadgets

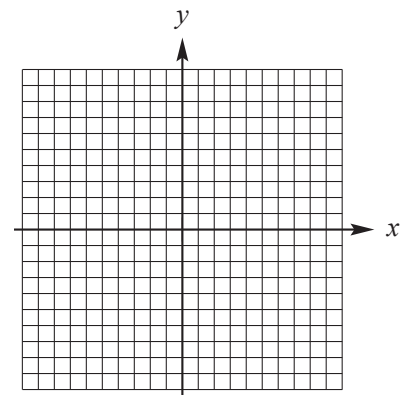

CHAPTER 9, FORM E

18. Find x in the equation $\begin{bmatrix} 3 & 4x \\ 2 & -4 \end{bmatrix} = \begin{bmatrix} 3 & x-9 \\ 2 & -4 \end{bmatrix}$. 18. _____

- a. 3 b. 0 c. 2 d. -3

Perform each operation, whenever possible, and give the entry in the first row and first column of the result.

19. $4 \begin{bmatrix} -6 & 5 \\ 0 & 1 \\ 2 & -3 \end{bmatrix} + \begin{bmatrix} 7 & 2 \\ 8 & 1 \end{bmatrix}$ 19. _____

- a. -31 b. -24
c. not possible d. 16

20. $\begin{bmatrix} -6 & 2 \\ 0 & 4 \end{bmatrix} - \frac{1}{2} \begin{bmatrix} 8 & -3 \\ 7 & -5 \end{bmatrix}$ 20. _____

- a. -2 b. -8
c. not possible d. -10

Write the second row of each matrix product, if the product can be found.

21. $\begin{bmatrix} 2 & 1 \\ 4 & -2 \\ 3 & -3 \end{bmatrix} \begin{bmatrix} 2 & -1 \\ 0 & 5 \end{bmatrix}$ 21. _____

- a. 4 3 b. 6 -18
c. 8 -14 d. product cannot be found

22. $\begin{bmatrix} -2 & 7 & -1 \end{bmatrix} \begin{bmatrix} 3 & -1 & 1 \\ 4 & 0 & -6 \end{bmatrix}$ 22. _____

- a. -7 3 b. 3 -12
c. -12 15 d. product cannot be found

23. If A is a 2×1 matrix and B is a 1×1 matrix, find the size of the product AB and the product BA , if these products can be found. 23. _____

- a. AB is 1×2 ; BA is 1×1
b. AB is 2×2 ; BA is 1×1
c. AB cannot be found; BA is 1×2
d. AB is 2×1 ; BA cannot be found

CHAPTER 9, FORM E

Find the entry in the first row and first column of each inverse, if the inverse exists.

24. $\begin{bmatrix} 3 & 1 \\ 1 & -3 \end{bmatrix}$ **24.** _____

a. $\frac{3}{10}$

b. $\frac{1}{10}$

c. $-\frac{3}{10}$

d. inverse does not exist

25. $\begin{bmatrix} -2 & 6 \\ 3 & -9 \end{bmatrix}$ **25.** _____

a. inverse does not exist

b. $\frac{1}{3}$

c. $\frac{1}{6}$

d. $-\frac{1}{9}$

26. $\begin{bmatrix} 1 & 1 & -2 \\ 1 & 0 & 1 \\ 1 & 2 & -2 \end{bmatrix}$ **26.** _____

a. $-\frac{1}{2}$

b. inverse does not exist

c. $\frac{2}{3}$

d. -1

27. Use the matrix inverse method to solve the system **27.** _____

$2x + 3y = 3$

$3x - 4z = 1$

$2y + z = 0$

Give the z -value of the solution only.

a. 3

b. -1

c. -3

d. 2

CHAPTER 9, FORM F
COLLEGE ALGEBRA AND TRIGONOMETRY

NAME _____
DATE _____

Choose the best answer.

Use substitution or elimination to solve each system. Identify any system that is inconsistent or has infinitely many solutions. If a system has dependent equations, express the solution with y arbitrary.

1. $2x - 3y = 1$ 1. _____
 $4x = 2 + 6y$

- a. $\{(5, 3)\}$
- b. $\left\{\left(\frac{3y+1}{2}, y\right)\right\}$; infinitely many solutions
- c. \emptyset ; inconsistent
- d. $\{(-4, -3)\}$

2. $\frac{3}{2}x - \frac{1}{3}y = -18$ 2. _____
 $\frac{3}{4}x + \frac{2}{9}y = -9$

- a. $\{(12, 0)\}$
- b. $\{(0, 12)\}$
- c. $\{(-12, 0)\}$
- d. \emptyset ; inconsistent

3. $2x - y + 2z = -7$ 3. _____
 $x + 2y + z = -1$
 $3x - y - z = -6$

- a. $\{(-1, 2, -4)\}$
- b. $\{(-2, 1, -1)\}$
- c. $\{(1, -7, 2)\}$
- d. $\{(0, 3, -2)\}$

Use the Gauss-Jordan method to solve each system. Give the x -value of the solution only.

4. $x - y = 5$ 4. _____
 $2x + 3y = 5$

- a. 4
- b. 3
- c. 2
- d. -1

5. $x + y - z = -2$ 5. _____
 $2x - y = 11$
 $3y + z = -6$

- a. 3
- b. 2
- c. 5
- d. 4

CHAPTER 9, FORM F

6. Find the equation that defines the parabola shown on the screen, using the information given at the bottom of the screen and in the table.

6. _____

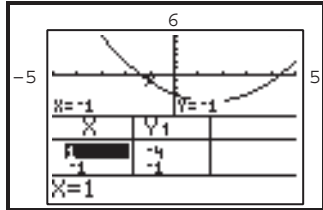

- a. $y = .5x^2 - x - 3$
 c. $y = .5x^2 - 1.5x + 3$

- b. $y = x^2 - 1.5x - 3$
 d. $y = .5x^2 - 1.5x - 3$

Evaluate each determinant.

7. $\begin{vmatrix} 9 & 10 \\ -11 & 8 \end{vmatrix}$

7. _____

- a. -182 b. 182 c. 99 d. -99

8. $\begin{vmatrix} -3 & 1 & 2 \\ -5 & 6 & 0 \\ -2 & 3 & -1 \end{vmatrix}$

8. _____

- a. 7 b. -27 c. -31 d. -23

9. Use Cramer's rule to find the x -value of the solution of the system
 $-2x + 3y = -9$
 $4x + 4y = 23.$

9. _____

- a. $\frac{25}{6}$ b. $\frac{23}{8}$ c. $\frac{21}{4}$ d. $\frac{1}{2}$

10. Use Cramer's rule to find the solution of the system
 $2x - y + 2z = 3$
 $x - y + z = 2$
 $x + y + 2z = 3$

10. _____

- a. $\{(-2, -1, 3)\}$ b. $\{(3, 4, 3)\}$
 c. $\{(2, 1, 3)\}$ d. $\{(1, 3, 4)\}$

CHAPTER 9, FORM F

11. Find the partial fraction decomposition of $\frac{2x^2 - 3x + 3}{x^3 - x^2 + 3x}$. 11. _____

- | | |
|---|---|
| <p>a. $\frac{1}{x} + \frac{3}{4(x+1)} + \frac{1}{4(x-3)}$</p> <p>c. $\frac{1}{x} + \frac{x+2}{x^2 - x + 3}$</p> | <p>b. $\frac{1}{x} + \frac{-3}{4(x+1)} + \frac{-1}{4(x-3)}$</p> <p>d. $\frac{1}{x} + \frac{x-2}{x^2 - x + 3}$</p> |
|---|---|

Solve each nonlinear system of equations.

12. $x^2 + y^2 = 30$ 12. _____
 $x + y = 8$

- | | |
|---|-----------------|
| a. $\{(4 + 2i, 4 - 2i), (4 - 2i, 4 + 2i)\}$ | b. $\{(5, 3)\}$ |
| c. $\{(4 + i, 4 - i), (4 - i, 4 + i)\}$ | d. \emptyset |

13. $x^2 + y^2 = 85$ 13. _____
 $x^2 - y^2 = 13$

- | | |
|-----------------------------|---|
| a. $\{(7, -6), (7, 6)\}$ | b. $\{(7, 6), (6, 7), (-7, -6), (-6, -7)\}$ |
| c. $\{(-7, -6), (-6, -7)\}$ | d. $\{(7, 6), (-7, 6), (7, -6), (-7, -6)\}$ |

14. A nonlinear system of two equations contains one equation whose graph is a parabola and another equation whose graph is a circle. What is the greatest possible number of points of intersection for these two graphs? 14. _____

- | | | | |
|------|------|------|------|
| a. 6 | b. 1 | c. 4 | d. 2 |
|------|------|------|------|

15. Find two numbers such that their sum is 5 and the difference of their squares is 105. 15. _____

- | | | | |
|--------------|-------------|---------------|---------------|
| a. -8 and 13 | b. -3 and 8 | c. -34 and 39 | d. -25 and 30 |
|--------------|-------------|---------------|---------------|

CHAPTER 9, FORM F

- 16.** Graph the solution set of
 $4y \geq x^2$
 $-1 \leq x \leq 3$.

16. _____

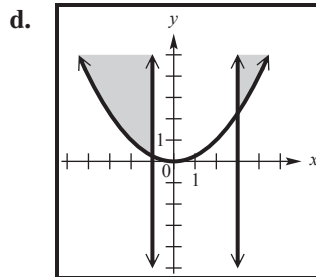
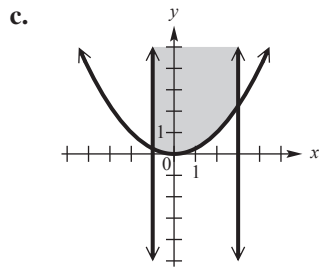
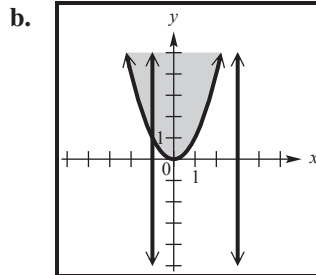
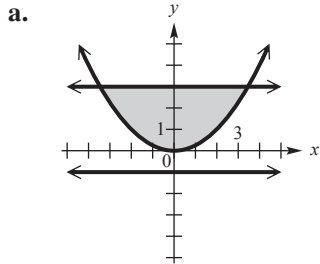

- 17.** Use linear programming to solve the problem.
 A company produces plastic cups and plates, both of which require time on two machines, *A* and *B*. Manufacturing a unit of cups requires 2 hr on machine *A* and 3 hr on machine *B*. Manufacturing a unit of plates requires 2 hr on machine *A* and 1 hr on machine *B*. Each machine is operated at most 12 hr per day.
 If 1 unit of cups produces \$50 profit per day and 1 unit of plates produces \$40 profit per day, find the number of units of cups and plates that will produce maximum profit each day.

17. _____

- | | |
|---|---|
| <p>a. 3 units of cups and
3 units of plates</p> <p>c. 4 units of cups and
6 units of plates</p> | <p>b. no units of cups and
6 units of plates</p> <p>d. 4 units of cups and
no units of plates</p> |
|---|---|

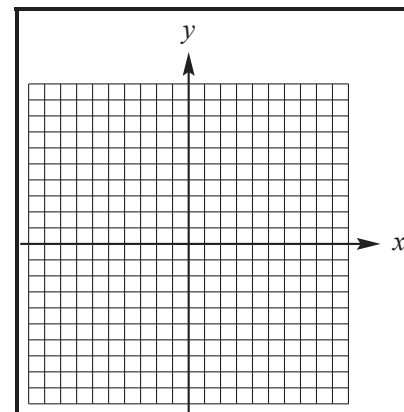

CHAPTER 9, FORM F

Find the entry in the first row and first column of each inverse, if the inverse exists.

24. $\begin{bmatrix} 6 & 1 \\ -3 & 2 \end{bmatrix}$

24. _____

a. $\frac{1}{6}$

b. -6

c. $\frac{2}{15}$

d. inverse does not exist

25. $\begin{bmatrix} -3 & -4 \\ 9 & 12 \end{bmatrix}$

25. _____

a. 3

b. $\frac{1}{3}$

c. $-\frac{1}{3}$

d. inverse does not exist

26. $\begin{bmatrix} 1 & -3 & 1 \\ 2 & -2 & 1 \\ 3 & 1 & 0 \end{bmatrix}$

26. _____

a. inverse does not exist

b. -1

c. $\frac{1}{2}$

d. $-\frac{3}{2}$

27. Use the matrix inverse method to solve the system
 $4x - 5y = 11$

$2x + z = 7$

$2y + z = 1.$

Give the z -value of the solution only.

27. _____

a. 1

b. 4

c. -1

d. -2

CHAPTER 10, FORM A
COLLEGE ALGEBRA AND TRIGONOMETRY

NAME _____
 DATE _____

Graph each parabola. Give the domain, range, vertex, and axis.

1. $x = 4y^2 + 8y$

1. vertex: _____

axis: _____

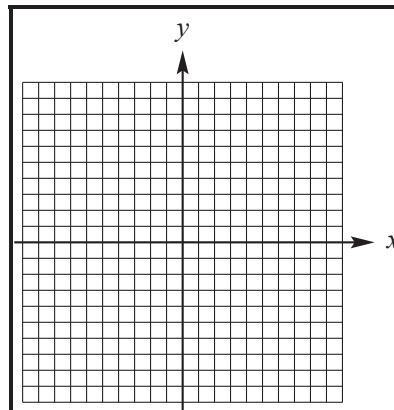

2. $y = 2x^2 + 8x$

2. vertex: _____

axis: _____

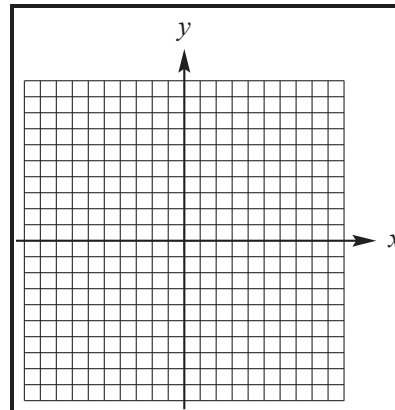

3. Give the coordinates of the focus and the equation of the directrix for the parabola with equation $y^2 = 12x$.

3. focus: _____
 directrix: _____

4. Write an equation for the parabola with vertex $(-3, 2)$, passing through the point $(0, 4)$, and opening downward.

4. _____

5. A radio telescope has a diameter of 120 feet and a maximum depth of 20 feet. Find the equation of the parabola that models the cross section of the dish if the vertex is placed at the origin and the parabola opens up.

5. _____

CHAPTER 10, FORM A

Graph each ellipse. Give the domain and range.

6. $16x^2 + 9y^2 = 144$

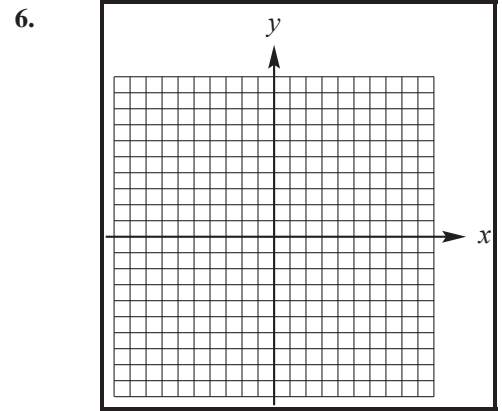

7. $\frac{(x+1)^2}{16} + \frac{(y-2)^2}{9} = 1$

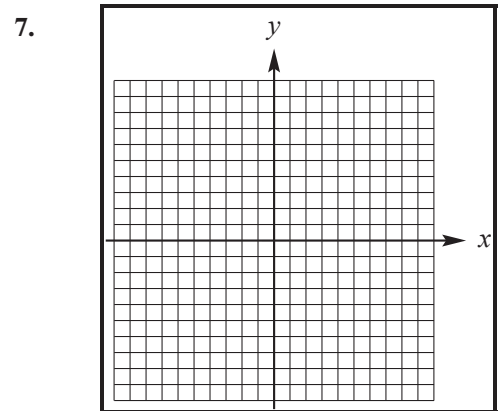

8. a. Graph $\frac{y}{3} = -\sqrt{1 - \frac{x^2}{25}}$.

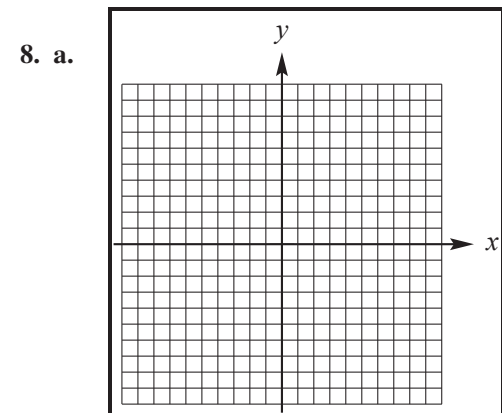

b. Tell whether the graph is that of a function.

b.

9. Write an equation for the ellipse centered at the origin having a vertical minor axis of length 12 and a major axis of length 24.

9. _____

CHAPTER 10, FORM A

10. An arch in the shape of the top half of an ellipse is 14 ft wide and 2 ft high at the center. Find the width of the arch between the points on the arch which are at a height of 1 ft. (Round your answer to two decimal places.)

Graph each hyperbola. Give the domain, range, and equations of the asymptotes.

11. $x^2 = 16y^2 - 16$

10. _____

11. domain: _____

range: _____

asymptotes: _____

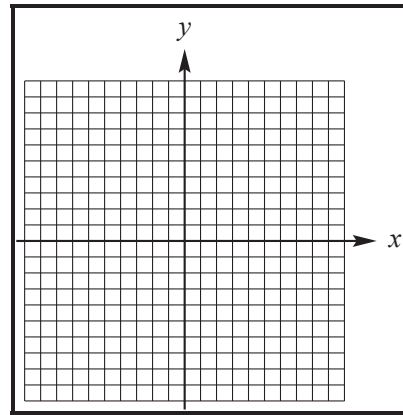

12. $\frac{y^2}{4} - \frac{x^2}{16} = 1$

12. domain: _____

range: _____

asymptotes: _____

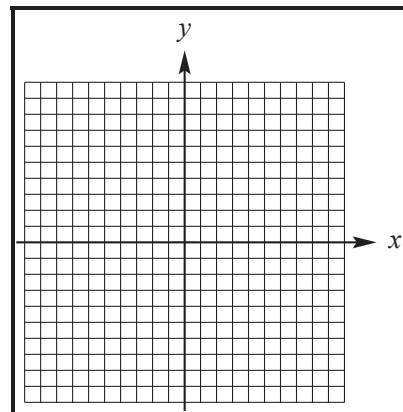

13. Find the equation of the hyperbola with y-intercepts ± 7 and foci at $(0, \sqrt{53})$ and $(0, -\sqrt{53})$.

13. _____

CHAPTER 10, FORM A

Identify the type of graph, if any, defined by each equation.

14. $x^2 + 6x - y^2 + 2y = 8$ 14. _____

15. $6x^2 + 4y^2 - 24 = 0$ 15. _____

16. $(x + 2)^2 = -8(y - 3)$ 16. _____

17. $\frac{(x + 2)^2}{4} + \frac{(y - 2)^2}{9} = 1$ 17. _____

18. $(y + 5)^2 = 4(x - 3)$ 18. _____

19. $\frac{x^2}{16} + \frac{y^2}{16} = 1$ 19. _____

20. Suppose the graph of the equation
 $(x + 4)^2 + (y - 5)^2 = 9$
is to be generated by a graphing calculator. What
two functions y_1 and y_2 would have to be used
to obtain the graph? 20. _____

CHAPTER 10, FORM B
COLLEGE ALGEBRA AND TRIGONOMETRY

NAME _____
 DATE _____

Graph each parabola. Give the domain, range, vertex, and axis.

1. $x = -2y^2 + 6y$

1. vertex: _____

axis: _____

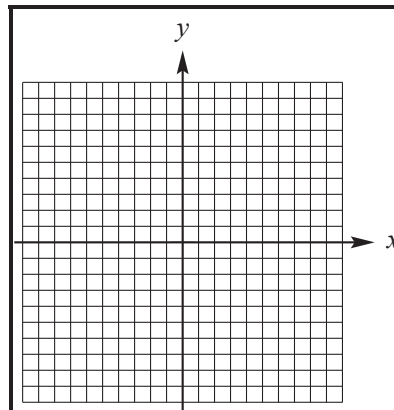

2. $y = -\frac{1}{2}(x-2)^2 + 3$

2. vertex: _____

axis: _____

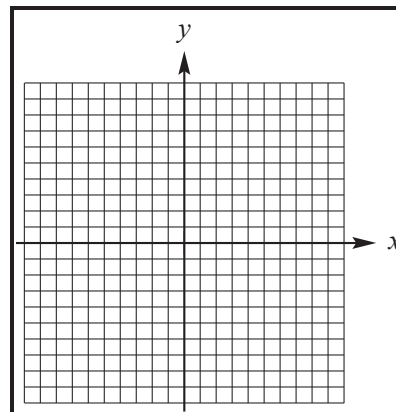

3. Give the coordinates of the focus and the equation of the directrix for the parabola with equation $x^2 = -20y$.

3. focus: _____
 directrix: _____

4. Write an equation for the parabola with vertex (4, 5), passing through the point (0, 7), and opening upward.

4. _____

5. A radio telescope has a diameter of 80 feet and a maximum depth of 8 feet. Find the equation of the parabola that models the cross section of the dish if the vertex is placed at the origin and the parabola opens up.

5. _____

CHAPTER 10, FORM B

Graph each ellipse. Give the domain and range.

6. $9x^2 = 225 - 25y^2$

6.

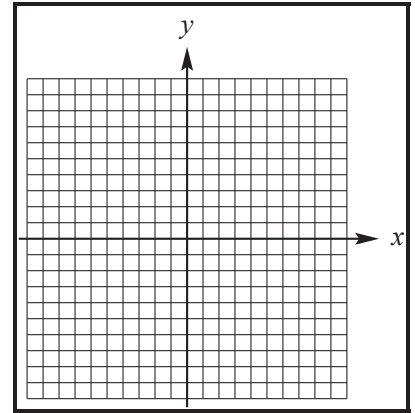

7. $\frac{x^2}{4} + \frac{(y+3)^2}{16} = 1$

7.

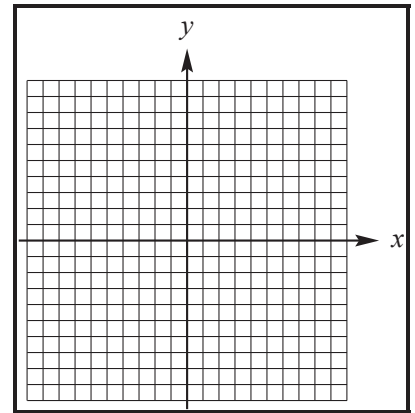

8. a. Graph $\frac{y}{2} = -\sqrt{1 - \frac{x^2}{25}}$.

8. a.

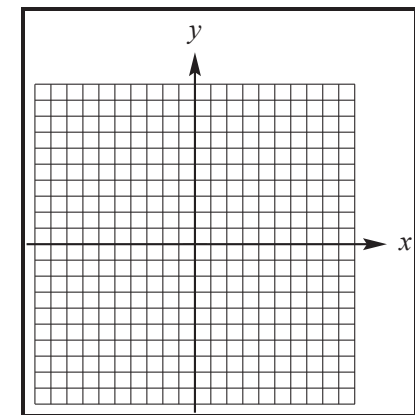

b. Tell whether the graph is that of a function.

b.

9. Write an equation for the ellipse centered at $(-4, 5)$ having a vertical major axis of length 8 and a minor axis of length 4.

9.

CHAPTER 10, FORM B

10. An arch in the shape of the top half of an ellipse is 10 m wide and 4 m high at the center. Find the width between the points on the arch which are at a height of 2 m.
(Round your answer to two decimal places.)

Graph each hyperbola. Give the domain, range, and equations of the asymptotes.

11. $4y^2 - 36x^2 = -144$

10. _____

11. domain: _____
range: _____
asymptotes: _____

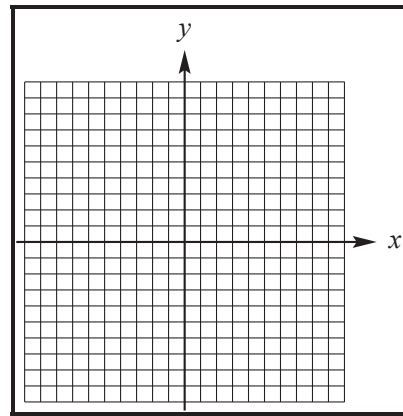

12. $\frac{y^2}{25} - \frac{x^2}{4} = 1$

12. domain: _____
range: _____
asymptotes: _____

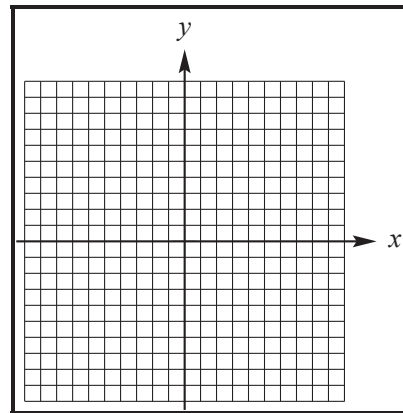

CHAPTER 10, FORM B

13. Find an equation of the hyperbola with x -intercepts ± 4 and the line with equation $y = -\frac{3}{4}x$ as an asymptote.

13. _____

Identify the type of graph, if any, defined by each equation.

14. $(x-1)^2 = 8(y+2)$

14. _____

15. $\frac{(x-2)^2}{16} + \frac{(y+4)^2}{25} = 0$

15. _____

16. $4x^2 + 9y^2 - 16x - 18y = 11$

16. _____

17. $x^2 - y^2 - 2x + 4y = 12$

17. _____

18. $2x^2 + 4x = 3 - 2y^2 - 3y$

18. _____

19. $x^2 - 8x + y + 9 = 0$

19. _____

20. Suppose the graph of the equation

$$\frac{(x+3)^2}{4} + \frac{(y-5)^2}{36} = 1$$

20. _____

is to be generated by a graphing calculator. What two functions y_1 and y_2 would have to be used to obtain the graph?

CHAPTER 10, FORM C
COLLEGE ALGEBRA AND TRIGONOMETRY

NAME _____
 DATE _____

Graph each parabola. Give the domain, range, vertex, and axis.

1. $x = -y^2 + 4y$

1. vertex: _____

axis: _____

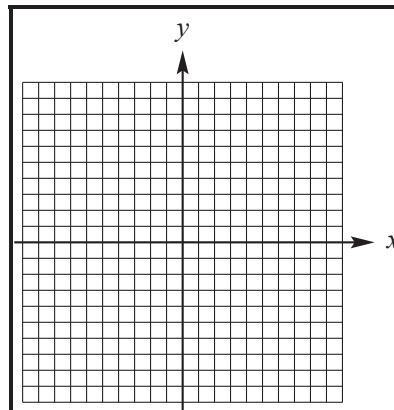

2. $y = x^2 - 4x$

2. vertex: _____

axis: _____

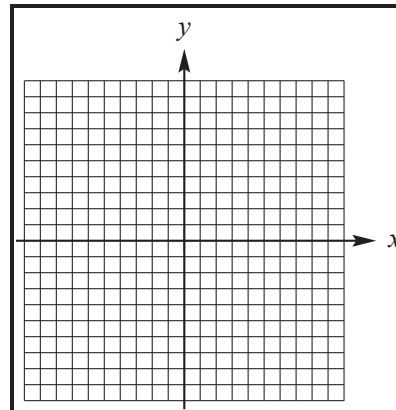

3. Give the coordinates of the focus and the equation of the directrix for the parabola with equation $y = \frac{1}{14}x^2$.

3. focus: _____

directrix: _____

4. Write an equation for the parabola with vertex $(-2, 6)$, passing through the point $(0, 3)$, and opening downward.

4. _____

5. A radio telescope has a diameter of 160 feet and a maximum depth of 20 feet. Find the equation of the parabola that models the cross section of the dish if the vertex is placed at the origin and the parabola opens up.

5. _____

CHAPTER 10, FORM C

Graph each ellipse. Give the domain and range.

6. $16x^2 + 25y^2 = 400$

6.

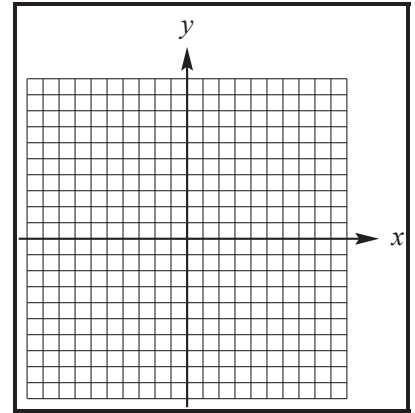

7. $\frac{(x+5)^2}{36} + \frac{(y-2)^2}{25} = 1$

7.

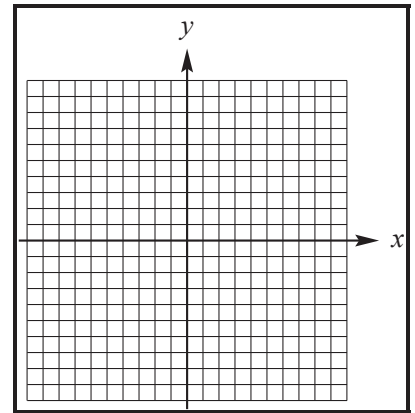

8. a. Graph $\frac{x}{4} = -\sqrt{1 - \frac{y^2}{36}}$.

8. a.

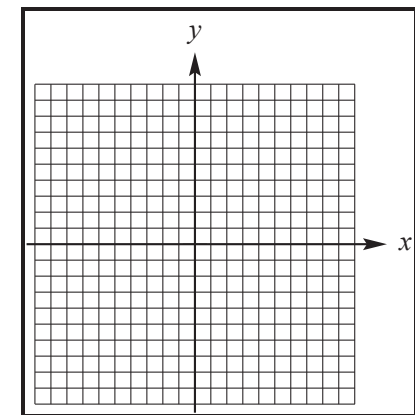

b. Tell whether the graph is that of a function.

b.

9. Write an equation for the ellipse centered at $(3, -4)$ having a horizontal minor axis of length 14 and a major axis of length 16.

9. _____

CHAPTER 10, FORM C

10. An arch in the shape of the top half of an ellipse is 4 m wide and 3 m high at the center. Find the width of the arch between the points on the arch which are at a height of 2 m. (Round your answer to two decimal places.)

Graph each hyperbola. Give the domain, range, and equations of the asymptotes.

11. $x^2 - 9y^2 = 36$

10. _____

11. domain: _____

range: _____

asymptotes: _____

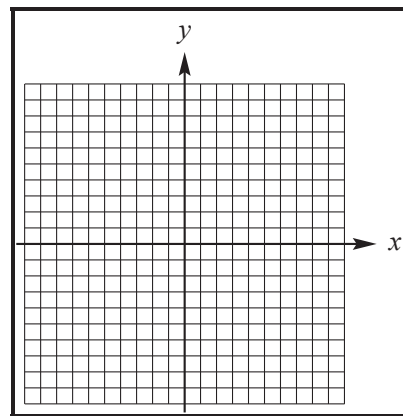

12. $\frac{y^2}{4} - \frac{x^2}{9} = 1$

12. domain: _____

range: _____

asymptotes: _____

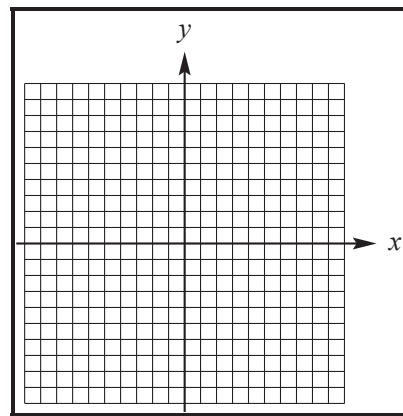

CHAPTER 10, FORM C

13. Find an equation of the hyperbola with y -intercepts ± 5 and the line with equation $y = \frac{5}{2}x$ as an asymptote.

13. _____

Identify the type of graph, if any, defined by each equation.

14. $y^2 - 4x^2 - 12y - 16x + 16 = 0$

14. _____

15. $2x^2 = 1 - 2y^2$

15. _____

16. $x^2 - 11x - y^2 + 13y - 8 = 0$

16. _____

17. $16x^2 + 96x + 4y^2 - 16y + 96 = 0$

17. _____

18. $4x^2 - 9y^2 + 24x - 36y - 36 = 0$

18. _____

19. $x^2 - 4x - 8y - 20 = 0$

19. _____

20. Suppose the graph of the equation $x^2 + y^2 + 6x + 2y = 8$

20. _____

is to be generated by a graphing calculator. What two functions y_1 and y_2 would have to be used to obtain the graph?

CHAPTER 10, FORM D
COLLEGE ALGEBRA AND TRIGONOMETRY

NAME _____
 DATE _____

Graph each parabola. Give the domain, range, vertex, and axis.

1. $x = 3y^2 - 6y$

1. vertex: _____

axis: _____

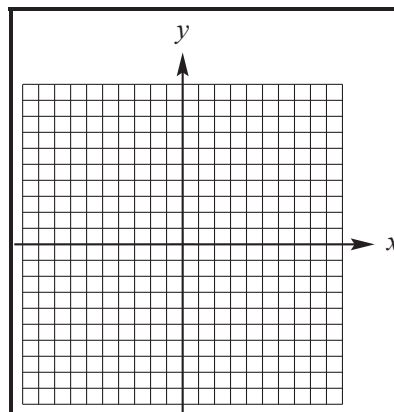

2. $y = -2x^2 + 6x$

2. vertex: _____

axis: _____

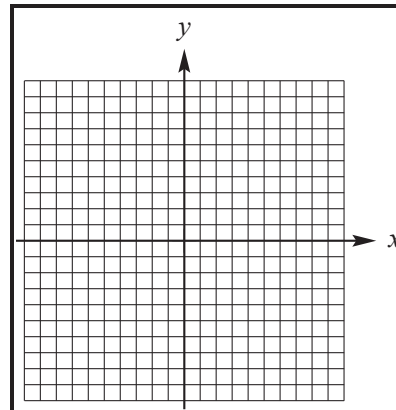

3. Give the coordinates of the focus and the equation of the directrix for the parabola with equation $x = 16y^2$.

3. focus: _____
 directrix: _____

4. Write an equation for the parabola with vertex $(-4, 2)$, passing through the point $(41, 5)$, and opening to the left.

4. _____

5. A radio telescope has a diameter of 80 feet and a maximum depth of 6 feet. Find the equation of the parabola that models the cross section of the dish if the vertex is placed at the origin and the parabola opens up.

5. _____

CHAPTER 10, FORM D

Graph each ellipse. Give the domain and range.

6. $9x^2 + 25y^2 = 225$

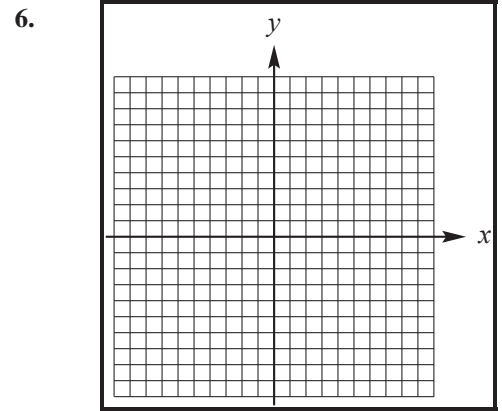

7. $(x + 3)^2 + \frac{y^2}{9} = 1$

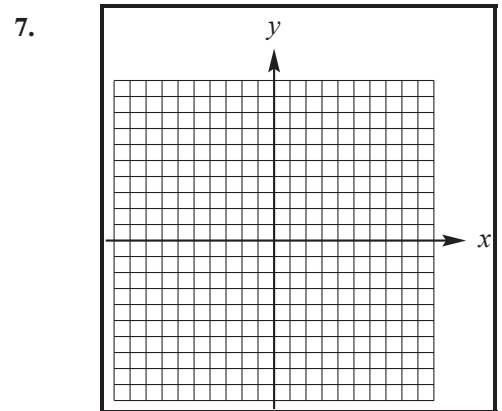

8. a. Graph $\frac{x}{5} = \sqrt{1 - \frac{y^2}{9}}$.

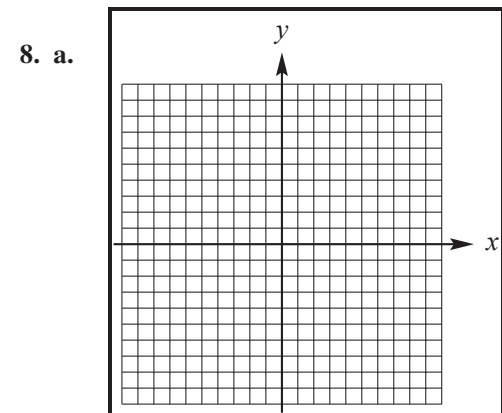

b. Tell whether the graph is that of a function.

b.

9. Write an equation for the ellipse centered at $(-8, 5)$ having a horizontal major axis of length 22 and a minor axis of length 12.

9. _____

CHAPTER 10, FORM D

10. An arch in the shape of the top half of an ellipse is 4 ft wide and 3 ft high at the center. Find the height of the arch 1 ft from the center of the bottom. (Round your answer to two decimal places.)

10. _____

Graph each hyperbola. Give the domain, range, and equations of the asymptotes.

11. $25x^2 - 9y^2 = 225$

11. domain: _____
 range: _____
 asymptotes: _____

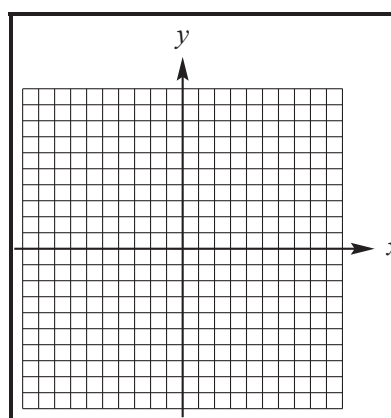

12. $\frac{x^2}{4} - \frac{y^2}{9} = 1$

12. domain: _____
 range: _____
 asymptotes: _____

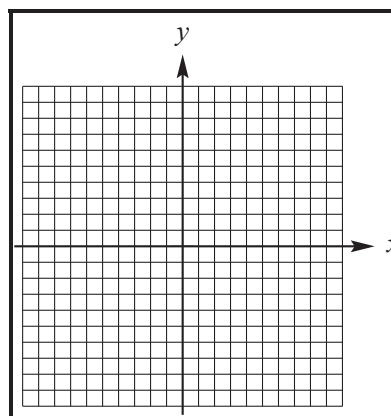

CHAPTER 10, FORM D

13. Find an equation of the hyperbola with center (5, 3) vertex at (5, 6) and passing through (1, 8).

13. _____

Identify the type of graph, if any, defined by each equation.

14. $4x^2 + \frac{y^2}{16} = 1$

14. _____

15. $(y + 2)^2 = -3(x - 3)$

15. _____

16. $\frac{x^2}{16} + \frac{y^2}{16} = 1$

16. _____

17. $4(y + 2)^2 - 25(x - 4)^2 = 100$

17. _____

18. $16(x - 6)^2 + 9(y - 4)^2 = 144$

18. _____

19. $(x + 5)^2 + 12(y + 4) = 0$

19. _____

20. Suppose the graph of the equation

$$\frac{x^2}{16} + \frac{y^2}{100} = 1$$

20. _____

is to be generated by a graphing calculator. What two functions y_1 and y_2 would have to be used to obtain the graph?

CHAPTER 10, FORM E
COLLEGE ALGEBRA AND TRIGONOMETRY

NAME _____
 DATE _____

Choose the best answer.

1. The graph of the equation $x = y^2 - 14y + 51$ is a parabola. Find the coordinates of its vertex and the equation of its axis.
 - a. Vertex: $\left(\frac{1}{2}, \frac{7}{2}\right)$; axis: $y = \frac{7}{2}$
 - b. Vertex: $(2, 7)$; axis: $y = 7$
 - c. Vertex: $\left(2, \frac{7}{2}\right)$; axis: $y = 2$
 - d. Vertex: $\left(\frac{1}{2}, -\frac{1}{2}\right)$; axis: $y = -\frac{1}{2}$

2. _____

3. The graph of the equation $y = 6x^2$ is a parabola. Find the coordinates of its focus and equation of its directrix.
 - a. Focus: $\left(0, -\frac{3}{2}\right)$; directrix: $x = \frac{1}{2}$
 - b. Focus: $\left(0, \frac{1}{24}\right)$; directrix: $y = -\frac{1}{24}$
 - c. Focus: $\left(0, \frac{3}{2}\right)$; directrix: $y = \frac{1}{2}$
 - d. Focus: $\left(0, -\frac{1}{24}\right)$; directrix: $x = \frac{1}{24}$

3. _____

4. Write an equation for the parabola with vertex $(-1, -8)$, passing through the point $(-3, -16)$, and opening downward.
 - a. $x + 8 = -2(y + 1)^2$
 - b. $x + 8 = 2(y + 1)^2$
 - c. $y + 8 = -2(x + 1)^2$
 - d. $y + 8 = 2(x + 1)^2$

4. _____

5. Write an equation for the ellipse centered at the origin having a vertical major axis of length 28 and a minor axis of length 12.
 - a. $\frac{x^2}{14} + \frac{y^2}{6} = 1$
 - b. $\frac{x^2}{196} + \frac{y^2}{36} = 1$
 - c. $\frac{x^2}{6} + \frac{y^2}{14} = 1$
 - d. $\frac{x^2}{36} + \frac{y^2}{196} = 1$

5. _____

CHAPTER 10, FORM E

6. Find an equation of the hyperbola with x -intercepts ± 4 and foci at $(0, \sqrt{65})$ and $(0, -\sqrt{65})$. 7. _____
- a. $\frac{x^2}{16} - \frac{y^2}{81} = 1$ b. $\frac{x^2}{81} - \frac{y^2}{16} = 1$
- c. $\frac{x^2}{49} - \frac{y^2}{16} = 1$ d. $\frac{x^2}{16} - \frac{y^2}{49} = 1$
7. An arch in the shape of the top half of an ellipse is 2 m wide and 6 m high at the center. Find the height of the arch .5 m from the center of the bottom. (Round your answer to two decimal places.) 6. _____
- a. 5.50 m b. 5.35 m
- c. 5.20 m d. 5.05 m

Identify the type of graph defined by each equation.

8. $\frac{y^2}{9} - \frac{x}{25} = 1$ 8. _____
- a. Ellipse b. Hyperbola
- c. Parabola d. No graph
9. $\frac{-y^2}{2} = 9 - x^2$ 9. _____
- a. Ellipse b. Circle
- c. Parabola d. Hyperbola
10. $x^2 - 4x + y^2 - 6y + 13 = 0$ 10. _____
- a. Ellipse b. Point
- c. Circle d. No graph
11. $16x^2 = 4y^2 + 64$ 12. _____
- a. Ellipse b. Point
- c. Circle d. Hyperbola
12. $x^2 - 2x + y^2 - 2y = 0$ 11. _____
- a. Ellipse b. Point
- c. Circle d. No graph
13. $10y^2 + x^2 = 5$ 13. _____
- a. Ellipse b. No graph
- c. Circle d. Hyperbola

CHAPTER 10, FORM E

14. Which of the following would be a function used to graph the equation $\frac{x^2}{16} - \frac{y^2}{25} = 1$ using a graphing calculator?

a. $y_1 = 5\sqrt{1 - \frac{x^2}{16}}$

b. $y_1 = 5\sqrt{\frac{x^2}{16} - 1}$

c. $y_1 = 5\sqrt{\frac{x^2}{16} + 1}$

d. $y_1 = -5\sqrt{\frac{x^2}{16} + 1}$

14. _____

Match the equation with its graph.

15. $\frac{(x+2)^2}{9} + \frac{(y-2)^2}{16} = 1$

16. _____

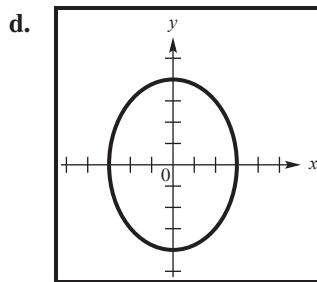
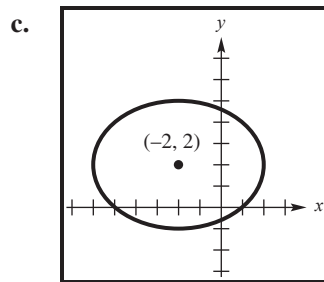
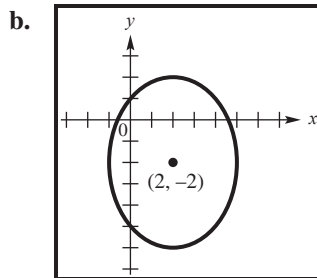
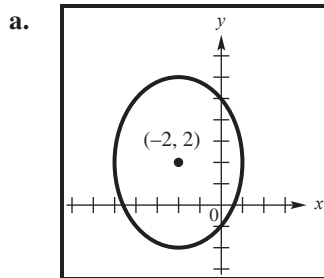

CHAPTER 10, FORM E

16. $x = (y - 2)^2$

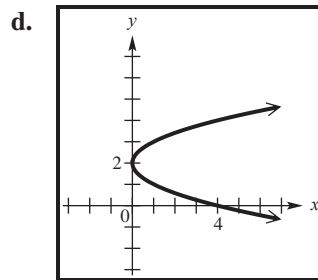
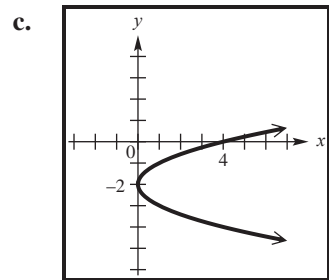
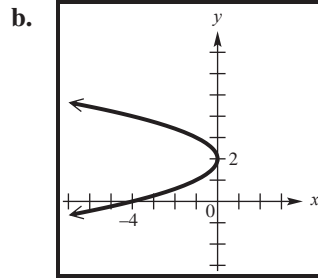
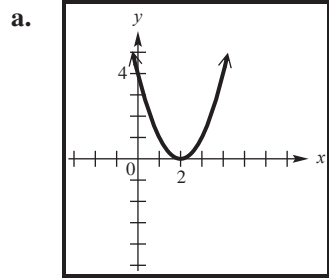

15. _____

17. $9x^2 = 36 - 4y^2$

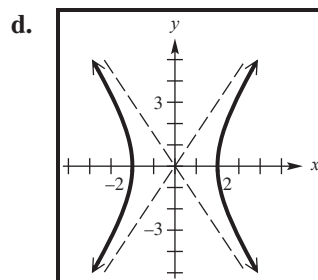
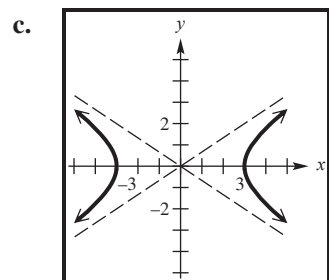
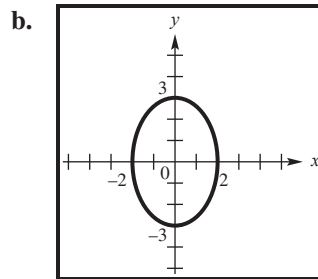
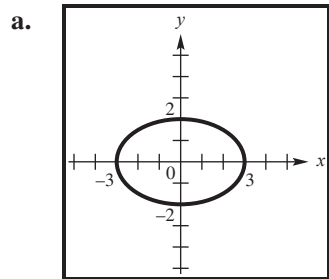

17. _____

CHAPTER 10, FORM E

18. $\frac{y^2}{9} - \frac{(x-4)^2}{9} = 1$

19. _____

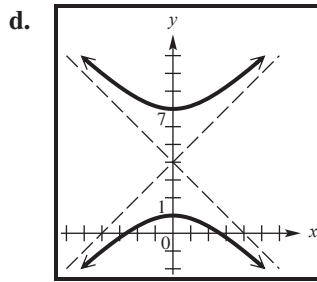
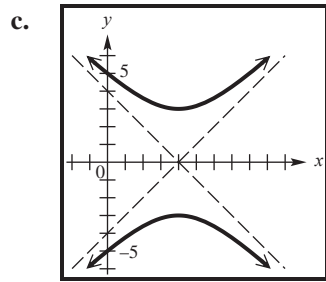
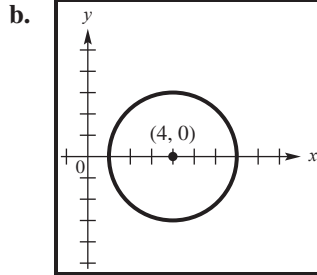
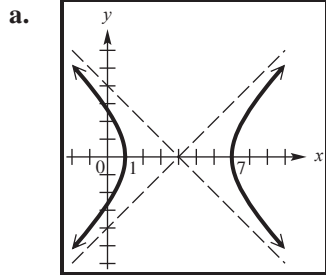

19. $\frac{y}{2} = \sqrt{1 + \frac{x^2}{16}}$

18. _____

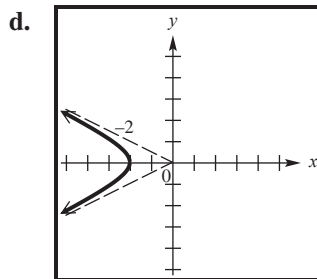
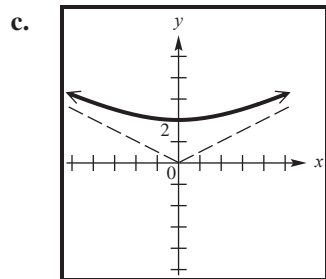
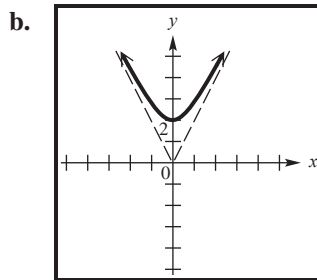
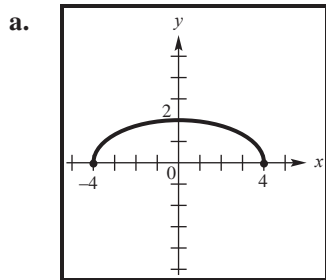

CHAPTER 10, FORM E

20. $y^2 = x^2 - 16$

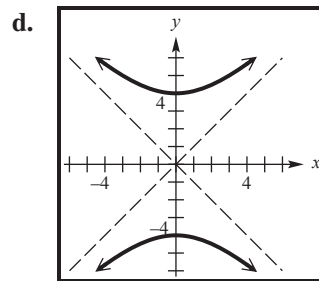
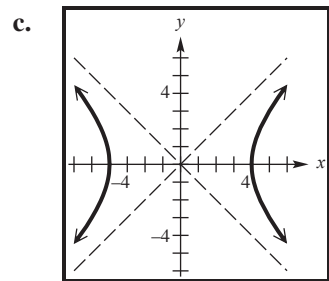
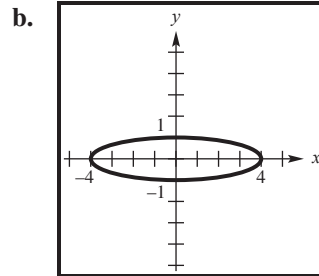
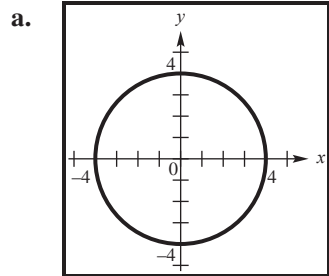

20. _____

CHAPTER 10, FORM F
COLLEGE ALGEBRA AND TRIGONOMETRY

NAME _____
DATE _____

Choose the best answer.

1. The graph of the equation $x = 2y^2 + 2y$ is a parabola. Find the coordinates of its vertex and the equation of its axis. 2. _____
- a. Vertex: $\left(-\frac{1}{2}, \frac{1}{2}\right)$; axis: $x = -\frac{1}{2}$
- b. Vertex: $\left(-\frac{1}{2}, \frac{1}{2}\right)$; axis: $y = \frac{1}{2}$
- c. Vertex: $\left(\frac{1}{2}, -\frac{1}{2}\right)$; axis: $y = -\frac{1}{2}$
- d. Vertex: $\left(\frac{1}{2}, -\frac{1}{2}\right)$; axis: $x = \frac{1}{2}$
2. Describe the parabola which is the graph of the equation $(y + 2)^2 = -2(x - 3)$ 1. _____
- a. Vertex at $(3, -2)$, opening to the left
- b. Vertex at $(-2, 3)$, opening to the right
- c. Vertex at $(1, 2)$, opening downward
- d. Vertex at $(1, -2)$, opening upward
3. The graph of the equation $x = -\frac{1}{2}y^2$ is a parabola. Find the coordinates of its focus and equation of its directrix. 3. _____
- a. Focus: $\left(-1, \frac{1}{9}\right)$; directrix: $y = -\frac{1}{2}$
- b. Focus: $\left(9, \frac{1}{9}\right)$; directrix: $y = \frac{1}{2}$
- c. Focus: $\left(-\frac{1}{2}, 0\right)$; directrix: $x = \frac{1}{2}$
- d. Focus: $(-1, -9)$; directrix: $x = -11$
4. Write an equation for the parabola with vertex $(-1, -8)$, passing through the point $(-3, -16)$, and opening downward. 4. _____
- a. $x + 8 = -2(y + 1)^2$ b. $x + 8 = 2(y + 1)^2$
- c. $y + 8 = -2(x + 1)^2$ d. $y + 8 = 2(x + 1)^2$

CHAPTER 10, FORM F

12. $x^2 = -5 - y^2$

- a. Parabola
- c. Ellipse

- b. Circle
- d. No graph

12. _____

13. $x^2 - y^2 = 49$

- a. Parabola
- c. Ellipse

- b. Hyperbola
- d. No graph

13. _____

14. Which of the following would be a function used to graph the equation

$$\frac{x^2}{25} - \frac{y^2}{16} = 1$$

using a graphing calculator?

a. $y_1 = 4\sqrt{1 - \frac{x^2}{25}}$

b. $y_1 = 4\sqrt{\frac{x^2}{25} + 1}$

c. $y_1 = 4\sqrt{\frac{x^2}{25} - 1}$

d. $y_1 = -4\sqrt{\frac{x^2}{25} + 1}$

14. _____

Match the equation with its graph.

15. $x = -(y-3)^2 + 5$

15. _____

a.

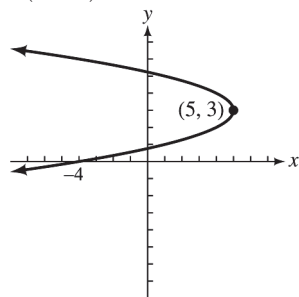

b.

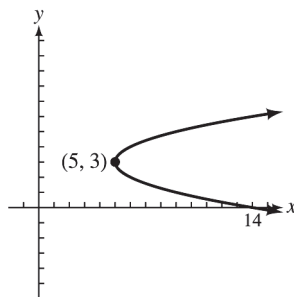

c.

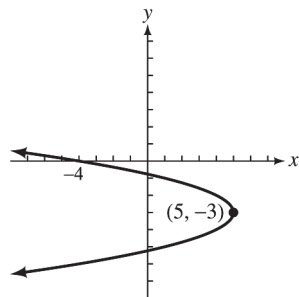

d.

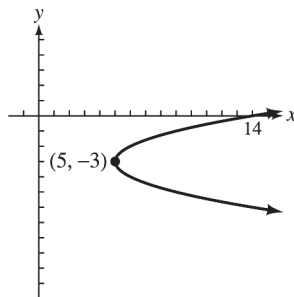

CHAPTER 10, FORM F

16. $\frac{x^2}{16} - \frac{y^2}{9} = 1$

16. _____

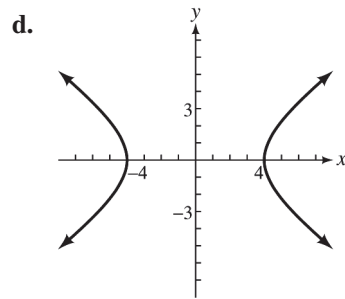
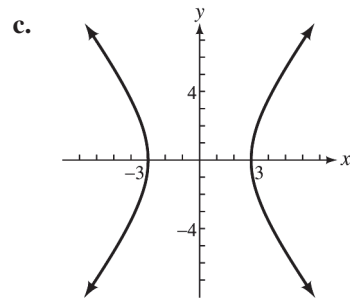
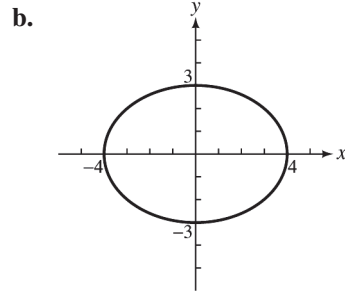
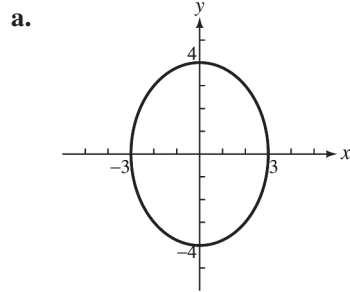

17. $16x^2 + 25y^2 = 400$

17. _____

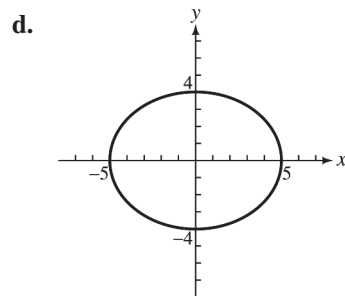
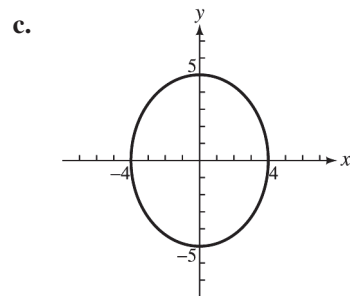
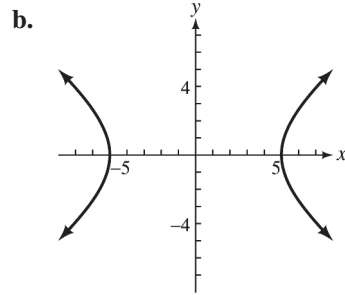
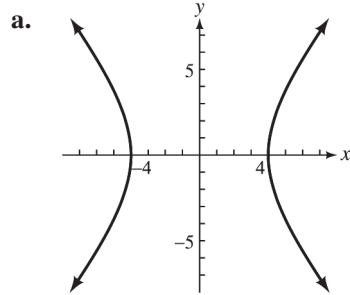

CHAPTER 10, FORM F

18. $9x^2 = 36 + 4y^2$

18. _____

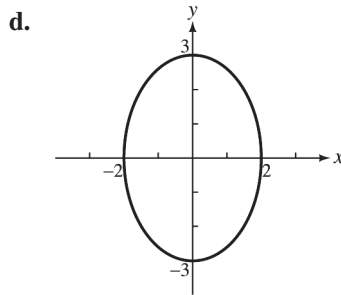
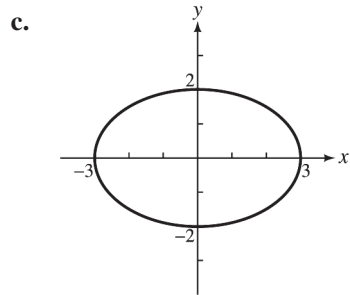
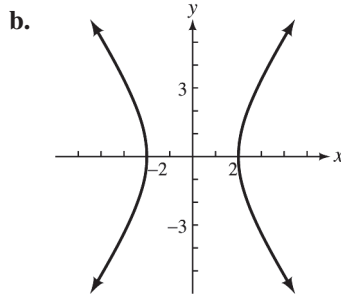
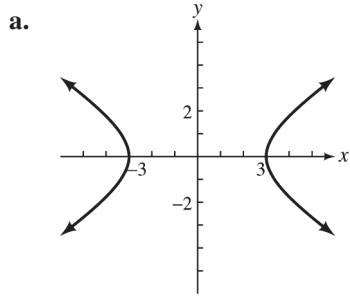

19. $9x^2 = 9 - y^2$

19. _____

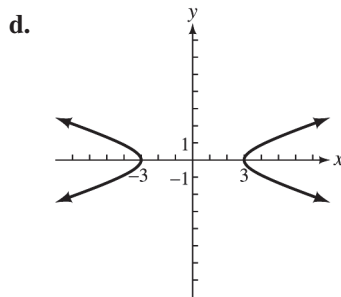
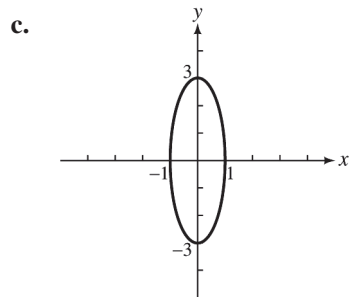
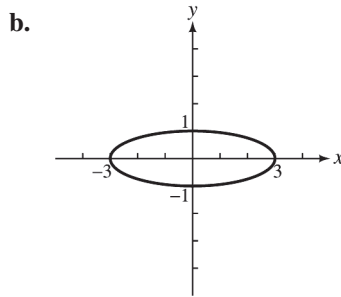
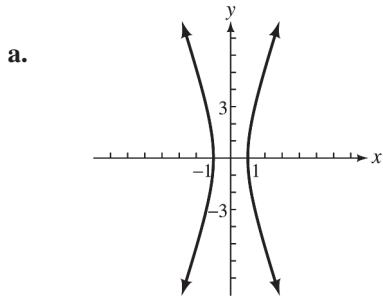

CHAPTER 10, FORM F

20. $y = \sqrt{16 - x^2}$

20. _____

a.

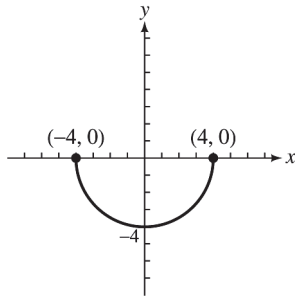

b.

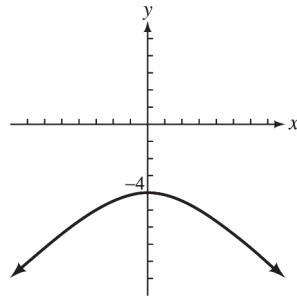

c.

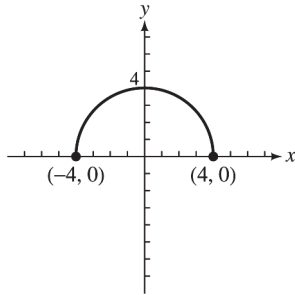

d.

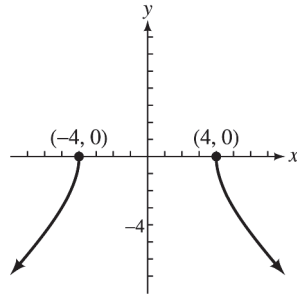

CHAPTER 11, FORM A
COLLEGE ALGEBRA AND TRIGONOMETRY

NAME _____
DATE _____

Write the first five terms of each sequence. State whether the sequence is arithmetic, geometric, or neither.

1. $a_1 = 1, a_n = n^2 + a_{n-1}$ for $n \geq 2$. 1. _____

2. $a_n = 1 + \frac{n}{2}$ 2. _____

3. $a_n = (-1)^n 2^n$ 3. _____

4. A certain arithmetic sequence has $a_8 = 47$ and $a_9 = 53$.
Find a_1 . 4. _____

5. A certain geometric sequence has $a_1 = 40$ and $a_4 = 135$.
Find a_3 . 5. _____

Find the sum of the first ten terms of each series.

6. arithmetic, with $a_1 = 8$ and $d = 17$ 6. _____

7. geometric, with $a_1 = \frac{1}{4}$ and $r = 2$ 7. _____

Evaluate each sum that exists.

8. $\sum_{k=1}^5 (k^2 + 4)$ 8. _____

9. $\sum_{j=1}^{\infty} 3(-2)^j$ 9. _____

10. $\sum_{i=1}^4 (3)^i$ 10. _____

11. $\sum_{k=1}^{\infty} 48\left(\frac{3}{8}\right)^k$ 11. _____

Use the binomial theorem to expand each expression.

12. $(3x - 1)^4$ 12. _____

13. $(x - 2y)^4$ 13. _____

14. Find the fifth term in the expansion of $(2x - 5y)^6$. 14. _____

Evaluate each expression.

15. $C(11, 2)$ 15. _____

16. $C(6, 2)$ 16. _____

CHAPTER 11, FORM A

17. $P(10, 7)$ 17. _____
18. $8!$ 18. _____
19. Use mathematical induction to prove that for all positive integers n , $6 + 8 + 10 + \dots + (4 + 2n) = n(n + 5)$. 19. _____

Solve each problem.

20. A fast food restaurant serves 7 different kinds of sandwiches, 4 different side dishes, and 8 different beverages. How many different meals consisting of one sandwich, one side dish, and one beverage can be served at the restaurant. 20. _____
21. A basketball team has a starting lineup of 5 different positions. If every member of a 12-member team can play one position at a time, how many different starting lineups can be chosen? 21. _____
22. A bag consists of 5 black, 4 red, 3 yellow, and 2 white marbles. How many samples of 5 marbles can be drawn from the bag in which 2 are black, 2 are red, and 1 is white? 22. _____
23. The following table shows the probability that a car on a certain freeway will have the indicated number of passengers. 23. _____

Number of passengers	0	1	2	3	4	5
Probability	0.40	0.35	0.10	0.08	0.05	0.02

A card is drawn from a standard deck of 52 cards. Find the probability that each of the following is drawn.

24. A card that is a spade. 24. _____
25. An ace or a red card 25. _____
26. In the card-drawing experiment above, what are the odds in favor of drawing a two or three? 26. _____

An experiment consists of tossing a single coin 6 times. Find the probability of the event described.

27. Heads appear exactly 4 times. 27. _____
28. No heads appear. 28. _____

CHAPTER 11, FORM B
COLLEGE ALGEBRA AND TRIGONOMETRY

NAME _____
DATE _____

Write the first five terms of each sequence. State whether the sequence is arithmetic, geometric, or neither.

1. $a_1 = 1, a_2 = 2, a_n = a_{n-2} + a_{n-1}$ for $n \geq 3$. 1. _____
2. $a_n = (-1)^{n+1}(n^2 - 1)$ 2. _____
3. $a_n = (-1)^{n+1} \cdot \frac{n+2}{n+1}$ 3. _____
4. A certain arithmetic sequence has $a_5 = 14$ and $a_2 = 5$.
Find a_{15} . 4. _____
5. A certain geometric sequence has $a_2 = 6$ and $a_3 = -18$.
Find a_5 . 5. _____

Find the sum of the first ten terms of each series.

6. arithmetic, with $a_1 = 31$ and $d = -4$ 6. _____
7. geometric, with $a_1 = \frac{8}{9}$ and $r = \frac{3}{2}$ 7. _____

Evaluate each sum that exists.

8. $\sum_{j=1}^{10} (1-4j)$ 8. _____
9. $\sum_{k=1}^5 (3k^2 + k)$ 9. _____
10. $\sum_{i=1}^{\infty} 270 \left(\frac{2}{3}\right)^i$ 10. _____
11. $\sum_{i=1}^{\infty} 162 \left(\frac{4}{3}\right)^i$ 11. _____

Use the binomial theorem to expand each expression.

12. $(3x - 2y)^4$ 12. _____
13. $(x - 2)^4$ 13. _____
14. Find the fifth term in the expansion of $(2a - b)^7$. 14. _____

Evaluate each expression.

15. $C(20, 11)$ 15. _____
16. $C(100, 97)$ 16. _____

CHAPTER 11, FORM B

17. $P(15, 8)$ 17. _____
18. $9!$ 18. _____
19. Use mathematical induction to prove that for all positive integers n , $2 + 8 + 14 + \dots + (6n - 4) = n(3n - 1)$. 19. _____

Solve each problem.

20. An interior decorator has 8 different drapery fabrics, each available in 6 colors and 5 different styles of draperies. How many different draperies are available? 20. _____
21. A club has 20 members, of whom 12 are women and 8 are men. How many 5-member committees can be elected, if each committee contains exactly 3 women? 21. _____
22. In how many ways can 6 competitors finish a race if there are no ties? 22. _____
23. The following table shows the probability that the temperature in Roseville on July 25 will be in the indicated range. 23. _____

Temperature	Below 50°	50°–69°	70°–89°	Above 89°
Probability	0.10	0.22	0.62	0.06

A card is drawn from a standard deck of 52 cards. Find the probability that each of the following is drawn.

24. A red card 24. _____
25. A three 25. _____
26. In the card-drawing experiment above, what are the odds against of drawing a queen or a five? 26. _____

An experiment consists of tossing a die 9 times. Find the probability of the event described.

27. Exactly 5 rolls result in a six. 27. _____
28. No rolls result in a three. 28. _____

CHAPTER 11, FORM C
COLLEGE ALGEBRA AND TRIGONOMETRY

NAME _____
DATE _____

Write the first five terms of each sequence. State whether the sequence is arithmetic, geometric, or neither.

1. $a_1 = 1, a_2 = 3, a_n = a_{n-1} + 2a_{n-2} + 1$ for $n \geq 3$. 1. _____

2. $a_n = \frac{3}{4}(-2)^n$ 2. _____

3. $a_n = (-1)^{n+1} \cdot \frac{n^2}{n^2 + 1}$ 3. _____

4. A certain arithmetic sequence has $a_2 = 1$ and $a_{18} = 49$.
Find a_{10} . 4. _____

5. A certain geometric sequence has $a_1 = 12$ and $a_4 = \frac{3}{2}$.
Find a_7 . 5. _____

Find the sum of the first ten terms of each series.

6. arithmetic, with $a_1 = 31$ and $d = -4$ 6. _____

7. geometric, with $a_1 = \frac{8}{9}$ and $r = \frac{3}{2}$ 7. _____

Evaluate each sum that exists.

8. $\sum_{i=1}^4 (-2) \cdot 3i$ 8. _____

9. $\sum_{j=3}^6 (3j - 5)$ 9. _____

10. $\sum_{k=1}^{\infty} 128 \left(\frac{3}{4}\right)^k$ 10. _____

11. $\sum_{i=1}^{\infty} 72 \left(\frac{5}{9}\right)^i$ 11. _____

Use the binomial theorem to expand each expression.

12. $(2x - 5)^4$ 12. _____

13. $(2x - 3y)^3$ 13. _____

14. Find the sixth term in the expansion of $(x - y)^{10}$. 14. _____

Evaluate each expression.

15. $C(20, 8)$ 15. _____

CHAPTER 11, FORM C

16. $C(68,66)$ 16. _____
17. $P(5,0)$ 17. _____
18. $10!$ 18. _____
19. Use mathematical induction to prove that for all positive integers n , $5 + 5^2 + 5^3 \dots + 5^n = \frac{5}{4}(5^n - 1)$. 19. _____

Solve each problem.

20. In how many different ways can a chairman, secretary, and treasurer be chosen from a 14-person board of trustees? 20. _____
21. A picture framer has 18 different prints, 14 mats, and 15 styles of frames available for motel rooms. How many different matted and framed prints can be ordered? 21. _____
22. A school club has 24 members, of whom 5 are freshman, 7 are sophomores, 9 are juniors, and 3 are seniors. In how many ways can the club select a 6-member committee made up of 2 freshman, 1 sophomore, and 3 juniors? 22. _____
23. The following table shows the probability that the number of cars in Joe's Used Car Lot on a given day will be in the indicated range. 23. _____

Number of cars	Less than 10	10–29	30–49	50–69	More than 69
Probability	0.10	0.15	0.30	0.25	0.20

A card is drawn from a standard deck of 52 cards. Find the probability that each of the following is drawn.

24. A King 24. _____
25. A spade or diamond 25. _____
26. In the card-drawing experiment above, what are the odds against drawing a heart? 26. _____

An experiment consists of tossing a single coin 8 times. Find the probability of the event described.

27. Heads and tails appear the same number of times. 27. _____
28. Exactly 2 heads appear. 28. _____

CHAPTER 11, FORM D
COLLEGE ALGEBRA AND TRIGONOMETRY

NAME _____
 DATE _____

Write the first five terms of each sequence. State whether the sequence is arithmetic, geometric, or neither.

1. $a_1 = 1, a_2 = 3, a_n = a_{n-1} + 2a_{n-2} + 1$ for $n \geq 3$. 1. _____
2. $a_n = 6n - 10$ 2. _____
3. $a_n = \left(-\frac{1}{2}\right)^{n-1}$ 3. _____
4. A certain arithmetic sequence has $a_1 = 135$ and $a_{15} = 51$.
Find a_{20} . 4. _____
5. A certain geometric sequence has $a_3 = 3$ and $a_6 = \frac{1}{9}$.
Find a_1 . 5. _____

Find the sum of the first ten terms of each series.

6. arithmetic, with $a_1 = 19$ and $d = 7$ 6. _____
7. geometric, with $a_1 = \frac{9}{2}$ and $r = \frac{4}{3}$ 7. _____

Evaluate each sum that exists.

8. $\sum_{k=1}^8 \frac{k}{k+1}$ 8. _____
9. $\sum_{j=1}^{\infty} 64 \left(\frac{3}{2}\right)^j$ 9. _____
10. $\sum_{i=1}^5 3 \cdot 1^i$ 10. _____
11. $\sum_{i=1}^{\infty} 24 \left(\frac{3}{4}\right)^i$ 11. _____

Use the binomial theorem to expand each expression.

12. $(2x + 3y)^4$ 12. _____
13. $(x - 3)^5$ 13. _____
14. Find the fourth term in the expansion of $(1 - 2b^2)^5$. 14. _____

Evaluate each expression.

15. $C(10, 3)$ 15. _____

CHAPTER 11, FORM D

16. $C(16,14)$ 16. _____
17. $P(15,4)$ 17. _____
18. $12!$ 18. _____
19. Use mathematical induction to prove that for all positive integers n , $5 + 8 + 11 \dots + (2 + 3n) = \frac{n(3n + 7)}{2}$. 19. _____

Solve each problem.

20. A professor grades homework by randomly checking 7 out of the 20 problems assigned. In how many different ways can this be done? 20. _____
21. In how many ways can 7 people be seated at a round table? 21. _____
22. Helen has 5 stuffed animals, 18 books, and 3 games. Helen's father tells her she can choose 1 stuffed animal, 1 book, and 1 game to take on the airplane to her grandmother's house. In how many ways can Helen make her choice? 22. _____
23. The following table shows the probability that a person on a certain diet will lose the indicated number of pounds during the first month. 23. _____

Number of pounds	0	1	2	3	4	More than 4
Probability	0.05	0.35	0.40	0.10	0.05	0.05

A card is drawn from a standard deck of 52 cards. Find the probability that each of the following is drawn.

24. A red card 24. _____
25. A three or a heart 25. _____
26. In the card-drawing experiment above, what are the odds against drawing a red three? 26. _____

An experiment consists of tossing a die 5 times. Find the probability of the event described.

27. Exactly 2 rolls result in 5. 27. _____
28. All but one roll result in a three. 28. _____

CHAPTER 11, FORM E
COLLEGE ALGEBRA AND TRIGONOMETRY

NAME _____
 DATE _____

1. $a_n = \frac{(-3)^n}{(n+2)!}$

1. _____

a. $-1, \frac{9}{7}, -\frac{9}{4}, -\frac{9}{2}, -\frac{243}{45}$

b. $-1, \frac{9}{7}, -\frac{9}{4}, \frac{9}{2}, -\frac{243}{45}$

c. $\frac{1}{2}, -\frac{3}{8}, \frac{9}{40}, -\frac{9}{80}, -\frac{27}{560}$

d. $-\frac{1}{2}, \frac{3}{8}, -\frac{9}{40}, \frac{9}{80}, -\frac{27}{560}$

2. $a_n = \frac{3n-1}{n^2+3n}$

2. _____

a. $1, \frac{7}{10}, \frac{5}{9}, \frac{13}{28}, \frac{2}{5}$

b. $\frac{1}{2}, \frac{1}{2}, \frac{4}{9}, \frac{11}{28}, \frac{7}{20}$

c. $\frac{1}{2}, \frac{5}{7}, \frac{2}{3}, \frac{11}{19}, \frac{1}{2}$

d. $\frac{2}{3}, \frac{5}{6}, \frac{8}{9}, \frac{11}{12}, \frac{14}{15}$

3. $a_1 = 1, a_n = \frac{n^2}{a_{n-1}}$ for $n \geq 2$

3. _____

a. $1, 4, \frac{9}{16}, \frac{245}{81}, \frac{225}{962}, \frac{225}{361}$

b. $1, 4, \frac{9}{4}, \frac{16}{9}, \frac{25}{16}$

c. $1, 4, \frac{9}{4}, \frac{64}{9}, \frac{225}{64}$

d. $1, 4, \frac{9}{4}, \frac{16}{81}, \frac{225}{256}$

4. A certain arithmetic sequence has $a_{15} = -79$ and $a_{16} = 8$. Find a_6 .

4. _____

- a. -862 b. -775 c. -1732 d. -1819

5. A certain geometric sequence has $a_1 = 2x$ and $a_4 = 16x^7$. Find a_5 .

5. _____

- a. $64x^9$ b. $32x^8$ c. $64x^8$ d. $32x^9$

Find the sum of the first ten terms of each series.

6. arithmetic, $a_1 = 15$ and $d = 12$

6. _____

- a. 123 b. 138 c. 432 d. 690

CHAPTER 11, FORM E

7. geometric, $a_1 = 24$ and $r = \frac{1}{3}$ 7. _____

- a. $\frac{8}{6561}$ b. $\frac{512}{6561}$ c. $\frac{236,192}{6561}$ d. $\frac{472,384}{6561}$

Evaluate each sum that exists.

8. $\sum_{k=1}^5 3 \cdot 2^k$ 8. _____

- a. 86 b. 44 c. 78 d. 102

9. $\sum_{j=3}^6 (j^2 - 2)$ 9. _____

- a. 186 b. 93 c. 729 d. 90

10. $\sum_{i=1}^{\infty} \frac{82}{3} \left(\frac{3}{2}\right)^i$ 10. _____

- a. does not exist b. 164

- c. $\frac{164}{3}$ d. 82

11. $\sum_{i=1}^{\infty} 50 \left(\frac{1}{4}\right)^i$ 11. _____

- a. $\frac{50}{3}$ b. 200 c. $\frac{200}{3}$ d. does not exist

Use the binomial theorem to expand each expression.

12. $(3x+4)^3$ 12. _____

- a. $9x^2 + 24x + 16$
 b. $27x^3 + 108x^2 + 144x + 64$
 c. $9x^6 + 12x^3 + 4096$
 d. $27x^3 + 108x^2 + 108x + 64$

13. $(2a+3)^5$ 13. _____

- a. $32a^5 + 240a^4 + 720a^3 + 1080a^2 + 810a + 243$
 b. $32a^5 + 160a^4 + 320a^3 + 320a^2 + 160a + 32$
 c. $32a^5 + 80a^4 + 240a^3 + 360a^2 + 270a + 81$
 d. $32a^5 - 240a^4 + 720a^3 - 1080a^2 + 810a - 243$

CHAPTER 11, FORM E

23. A game involves choosing 4 numbers from the numbers 1 through 13. **23.** _____
 In how many ways can this be done?

- a.** 695 **b.** 715 **c.** 723 **d.** 17,160

24. Suppose that a family has 5 children and the probability of having a girl **24.** _____
 is 0.5. What is the probability of having no girls?

- a.** 0.06252 **b.** 0.15625 **c.** 0.31255 **d.** 0.03125

A card is drawn from a standard deck of 52 cards. Find the probability that each of the following is drawn.

25. A six **25.** _____

- a.** $\frac{2}{13}$ **b.** $\frac{1}{13}$ **c.** $\frac{1}{26}$ **d.** $\frac{1}{52}$

26. A five or a black card **26.** _____

- a.** $\frac{7}{13}$ **b.** $\frac{6}{13}$ **c.** $\frac{5}{13}$ **d.** $\frac{15}{52}$

27. In the preceding card-drawing experiment, what are the odds against **27.** _____
 drawing a face card?

- a.** 3 to 23 **b.** 10 to 42 **c.** 3 to 10 **d.** 10 to 3

An experiment consists of tossing a die 4 times. Find the probability of the event described.

28. Exactly 3 rolls result in a two. **28.** _____

- a.** 0.0154 **b.** 0.217 **c.** 0.500 **d.** 0.863

29. No rolls result in a two. **29.** _____

- a.** 0.482 **b.** 0.550 **c.** 0.667 **d.** 0.964

30. The following table shows the probability that attendance at an art museum **30.** _____
 on a Saturday will be in the indicated range.

Attendance	Less than 50	50–99	100–149	150–200	More than 200
Probability	0.05	0.10	0.35	0.40	0.10

Find the probability that less than 150 people attend the art museum on a Saturday.

- a.** 0.55 **b.** 0.50 **c.** 0.45 **d.** 0.15

CHAPTER 11, FORM F
COLLEGE ALGEBRA AND TRIGONOMETRY

NAME _____
DATE _____

1. $a_n = \left(-\frac{3}{4}\right)(-2)^n$ 1. _____

a. $\frac{3}{2}, -\frac{3}{4}, \frac{3}{8}, -\frac{3}{16}, \frac{3}{32}$

b. $-\frac{3}{2}, -3, -6, -12, -24$

c. $-\frac{3}{2}, 3, -6, 12, -24$

d. $\frac{3}{2}, -3, 6, -12, 24$

2. $a_n = (-1)^{n-1} \left(\frac{n+1}{2n-1}\right)$ 2. _____

a. $2, -1, \frac{4}{5}, -\frac{5}{7}, \frac{2}{3}$

b. $2, 1, \frac{4}{5}, \frac{5}{7}, \frac{2}{3}$

c. $-2, 1, -\frac{4}{5}, \frac{5}{7}, -\frac{2}{3}$

d. $-2, 1, \frac{4}{5}, -\frac{5}{7}, \frac{2}{3}$

3. $a_1 = 1, a_n = \frac{n}{a_{n-1}}$ for $n \geq 2$ 3. _____

a. $1, 2, \frac{3}{2}, \frac{8}{3}, \frac{15}{8}$

b. $1, 3, \frac{3}{2}, \frac{8}{3}, \frac{15}{3}$

c. $2, \frac{3}{2}, \frac{8}{3}, \frac{15}{8}, \frac{16}{5}$

d. $1, \frac{1}{2}, \frac{1}{3}, \frac{1}{4}, \frac{1}{5}$

4. A certain arithmetic sequence has $a_1 = 56$ and $a_{11} = 26$. Find a_{17} . 4. _____

a. 5

b. -8

c. -5

d. 8

CHAPTER 11, FORM F

Use the binomial theorem to expand each of the following.

12. $(4x + 3y)^3$ 12. _____

- a. $64x^3 + 144x^2 + 108xy^2 + 27y^3$
- b. $64x^3 - 144x^2y - 108xy^2 + 27y^3$
- c. $64x^3 + 144x^2y^2 + 27y^3$
- d. $64x^3 + 27y^3$

13. $(3b + 2)^5$ 13. _____

- a. $32b^5 - 240b^4 + 720b^3 - 1080b^2 + 810b - 243$
- b. $243b^5 - 810b^4 + 1080b^3 - 720b^2 + 240b - 32$
- c. $32b^5 + 240b^4 + 720b^3 + 1080b^2 + 810b + 243$
- d. $243b^5 + 180b^4 + 1080b^3 + 720b^2 + 240b + 32$

14. Find the fourth term in the expansion of $(3y - z)^7$. 14. _____

- a. $945y^3z^4$
- b. $2835y^4z^3$
- c. $-105y^4z^3$
- d. $-2835y^4z^3$

15. $C(10, 5)$ 15. _____

- a. 35
- b. 500
- c. 252
- d. 30,240

16. $C(16, 4)$ 16. _____

- a. 524,160
- b. 43,680
- c. 1820
- d. 460

17. $P(10, 9)$ 17. _____

- a. 120
- b. 3,628,800
- c. 60,480
- d. 6,188,650

18. $P(6, 1)$ 18. _____

- a. 0
- b. 1
- c. 6
- d. 24

CHAPTER 2, FORM A
COLLEGE ALGEBRA AND TRIGONOMETRY

NAME _____
 DATE _____

1. Match the set described in Column I with the correct interval notation from Column II. Choices in Column II may be used once, more than once, or not at all.

I	II
a. Domain of $f(x) = \sqrt{x-3}$	A. $(-\infty, \infty)$
b. Range of $f(x) = \sqrt{x} - 3$	B. $[3, \infty)$
c. Domain of $f(x) = x^2 - 16$	C. $[0, 2]$
d. Range of $y = 2x^2$	D. $[0, \infty)$
e. Domain of $f(x) = \sqrt[3]{x-2}$	E. $[-3, 3]$
f. Range of $f(x) = \sqrt[3]{x} + 2$	F. $(-\infty, -2]$
g. Domain of $f(x) = x+2 $	G. $[-3, \infty)$
h. Range of $f(x) = x +3$	H. $[-7, \infty)$
i. Domain of $y = 2s^2$	
j. Range of $f(x) = x^2 - 7$	

1. a. _____
 b. _____
 c. _____
 d. _____
 e. _____
 f. _____
 g. _____
 h. _____
 i. _____
 j. _____

The graph shows the line that passes through the points $(-5, -3)$ and $(-1, 4)$. Refer to it to answer Exercises 2–6.

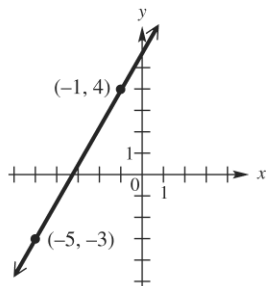

- | | |
|---|----------|
| 2. What is the slope of the line? | 2. _____ |
| 3. What is the distance between the two points shown? | 3. _____ |
| 4. What are the coordinates of the midpoint of the <i>segment</i> joining the two points? | 4. _____ |
| 5. Find the standard form of the equation of the line. | 5. _____ |
| 6. Write the linear function defined by $f(x) = ax + b$ that has this line as its graph. | 6. _____ |

CHAPTER 2, FORM A

Tell whether each graph is that of a function. Give the domain and the range. If it is a function, give the intervals where it is increasing, decreasing, or constant.

7.

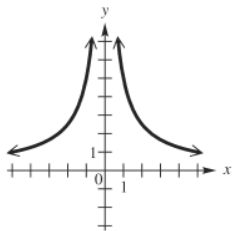

7. _____

8.

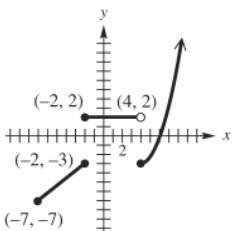

8. _____

9. Suppose point P has coordinates $\left(\frac{2}{5}, \frac{3}{7}\right)$.

- a. What is the equation of the vertical line through P ?
- b. What is the equation of the horizontal line through P ?

9. a. _____
 b. _____

10. Find the slope-intercept form of the equation of the line passing through $(2, 5)$ and

- a. parallel to the graph of $y = 4x - 7$;
- b. perpendicular to the graph of $y = 4x - 7$.

10. a. _____
 b. _____

Graph each relation.

11. $x = 2|y - 3| + 1$

11.

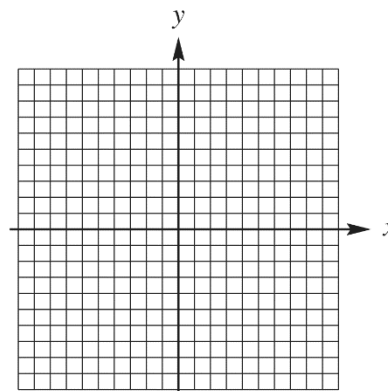

CHAPTER 2, FORM A

12. $f(x) = \square x \square + 2$

12.

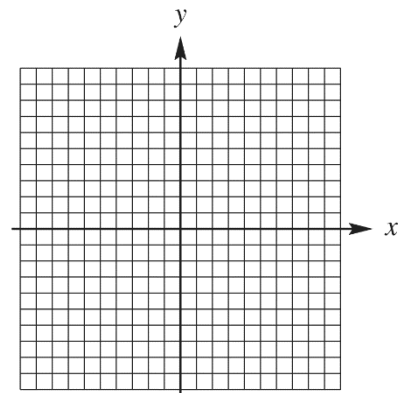

13. $f(x) = \begin{cases} 2x-1 & \text{if } x < 0 \\ -3x-1 & \text{if } x \geq 0 \end{cases}$

13.

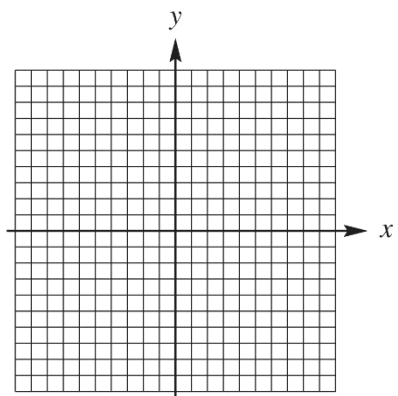

14. Explain how the graph of $y = -\frac{1}{2}\sqrt{x+3} + 5$ can be obtained from the graph of $y = \sqrt{x}$.

14. _____

15. Determine whether the graph of $2x^2 + 3y^2 = 1$ is symmetric with respect to

15. a. _____

a. the x -axis,

b. _____

b. the y -axis,

c. _____

c. the origin.

Given $f(x) = x^2 - 1$ and $g(x) = 2x + 1$, find each of the following. Simplify the expressions when possible.

16. $(fg)(x)$

16. _____

17. $(f+g)(x)$

17. _____

18. the domain of $\frac{g}{f}$

18. _____

CHAPTER 2, FORM A

19. $\frac{f(x+h) - f(x)}{h}$

19. _____

20. $(f - g)(0)$

20. _____

21. $\left(\frac{f}{g}\right)(2)$

21. _____

22. $(f \circ g)(x)$

22. _____

23. $(f \circ g)(-2)$

23. _____

24. $(g \circ f)(x)$

24. _____

25. $(g \circ f)(-2)$

25. _____

CHAPTER 2, FORM B
COLLEGE ALGEBRA AND TRIGONOMETRY

NAME _____
 DATE _____

1. Match the set described in Column I with the correct interval notation from Column II. Choices in Column II may be used once, more than once, or not at all.

I	II
a. Domain of $f(x) = \sqrt{x-4}$	A. $(-\infty, \infty)$
b. Range of $f(x) = \sqrt{x} - 2$	B. $[-2, \infty)$
c. Domain of $f(x) = 3x^2$	C. $[0, 2]$
d. Range of $f(x) = x^2 + 5$	D. $[0, \infty)$
e. Domain of $f(x) = \sqrt[3]{x-8}$	E. $[-3, 3]$
f. Range of $f(x) = \sqrt[3]{x} - 1$	F. $(-\infty, -2]$
g. Domain of $f(x) = x-2 $	G. $[5, \infty)$
h. Range of $f(x) = x + 5$	H. $[4, \infty)$
i. Domain of $x = 2y^2$	
j. Range of $x = 2y^2$	

1. a. _____
 b. _____
 c. _____
 d. _____
 e. _____
 f. _____
 g. _____
 h. _____
 i. _____
 j. _____

The graph shows the line that passes through the points $(-2, -1)$ and $(4, -3)$. Refer to it to answer Exercises 2–6.

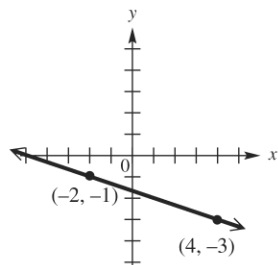

- | | |
|---|----------|
| 2. What is the slope of the line? | 2. _____ |
| 3. What is the distance between the two points shown? | 3. _____ |
| 4. What are the coordinates of the midpoint of the <i>segment</i> joining the two points? | 4. _____ |
| 5. Find the standard form of the equation of the line. | 5. _____ |
| 6. Write the linear function defined by $f(x) = ax + b$ that has this line as its graph. | 6. _____ |

CHAPTER 2, FORM B

Tell whether each graph is that of a function. Give the domain and the range. If it is a function, give the intervals where it is increasing, decreasing, or constant.

7.

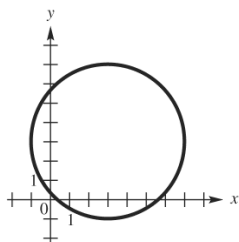

7. _____

8.

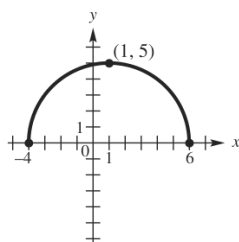

8. _____

Graph each relation.

9. $f(x) = 2 - |3x|$

9.

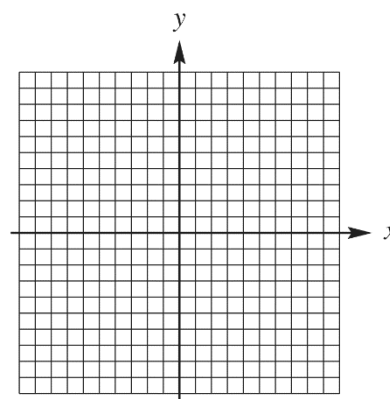

10. $f(x) = \frac{1}{2}x$

10.

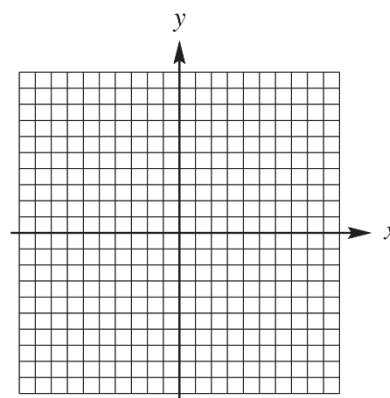

CHAPTER 2, FORM B

11.
$$f(x) = \begin{cases} -2x & \text{if } x < -3 \\ 4 & \text{if } -3 \leq x \leq 2 \\ x-4 & \text{if } x \geq 2 \end{cases}$$

11.

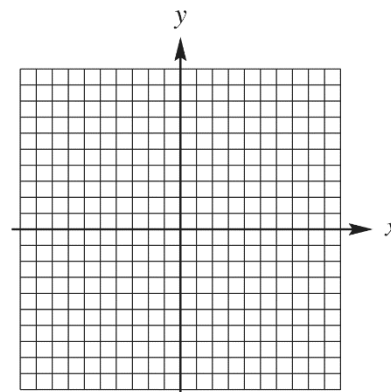

12. Suppose point P has coordinates $\left(\frac{5}{8}, -\frac{7}{9}\right)$.

- a. What is the equation of the vertical line through P ?
 b. What is the equation of the horizontal line through P ?

12. a. _____

b. _____

13. Find the slope-intercept form of the equation of the line passing through $(-6, 3)$ and

- a. parallel to the graph of $y = -3x - 12$;
 b. perpendicular to the graph of $y = -3x - 12$.

13. a. _____

b. _____

14. Explain how the graph of $y = -\frac{1}{3}\sqrt{x+4} + 2$ can be obtained from the graph of $y = \sqrt{x}$.

14. _____

15. Determine whether the graph of $y^2 = 3x$ is symmetric with respect to

- a. the x -axis,
 b. the y -axis,
 c. the origin.

15. a. _____

b. _____

c. _____

Given $f(x) = 2x^2 + 7x + 6$ and $g(x) = 3x - 2$, find each of the following. Simplify the expressions when possible.

16. $(fg)(x)$

16. _____

17. $(f - g)(x)$

17. _____

18. the domain of $\frac{g}{f}$

18. _____

CHAPTER 2, FORM B

19. $\frac{f(x+h) - f(x)}{h}$

19. _____

20. $(f + g)(1)$

20. _____

21. $\left(\frac{g}{f}\right)(0)$

21. _____

22. $(f \circ g)(x)$

22. _____

23. $(f \circ g)(1)$

23. _____

24. $(g \circ f)(x)$

24. _____

25. $(g \circ f)(1)$

25. _____

CHAPTER 2, FORM C
COLLEGE ALGEBRA AND TRIGONOMETRY

NAME _____
 DATE _____

1. Match the set described in Column I with the correct interval notation from Column II. Choices in Column II may be used once, more than once, or not at all.

I	II
a. Domain of $f(x) = \sqrt{x+2}$	A. $(-\infty, \infty)$
b. Range of $f(x) = \sqrt{x} - 4$	B. $[-4, \infty)$
c. Domain of $f(x) = x^2 - 1$	C. $[0, 2]$
d. Range of $f(x) = x^2 - 16$	D. $[0, \infty)$
e. Domain of $f(x) = \sqrt[3]{x-2}$	E. $[-3, 3]$
f. Range of $f(x) = \sqrt[3]{x} + 2$	F. $(-\infty, -3]$
g. Domain of $f(x) = x+3 $	G. $[-1, \infty)$
h. Range of $f(x) = x - 3$	H. $[-2, \infty)$
i. Domain of $y = 2x^2$	
j. Range of $y = x^2 - 3$	

1. a. _____
 b. _____
 c. _____
 d. _____
 e. _____
 f. _____
 g. _____
 h. _____
 i. _____
 j. _____

The graph shows the line that passes through the points $(-3, -5)$ and $(3, -2)$. Refer to it to answer Exercises 2–6.

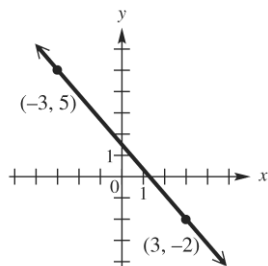

- | | |
|--|----------|
| 2. What is the slope of the line? | 2. _____ |
| 3. What is the distance between the two points shown? | 3. _____ |
| 4. What are the coordinates of the midpoint of the segment joining the two points? | 4. _____ |
| 5. Find the standard form of the equation of the line. | 5. _____ |
| 6. Write the linear function defined by $f(x) = ax + b$ that has this line as its graph. | 6. _____ |

CHAPTER 2, FORM C

Tell whether each graph is that of a function. Give the domain and the range. If it is a function, give the intervals where it is increasing, decreasing, or constant.

7.

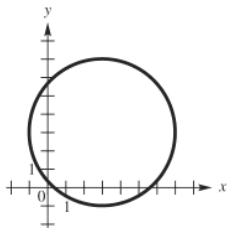

7. _____

8.

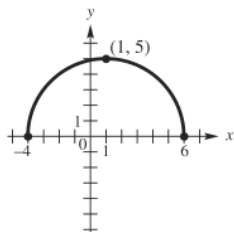

8. _____

9. Suppose point P has coordinates $(2\sqrt{2}, -\sqrt{5})$.

- a. What is the equation of the vertical line through P ?
 b. What is the equation of the horizontal line through P ?

9. a. _____
 b. _____

10. Find the slope-intercept form of the equation of the line passing through $(4, -2)$ and

- a. parallel to the graph of $x = \frac{5}{4}y - 2$;
 b. perpendicular to the graph of $x = \frac{5}{4}y - 2$;

10. a. _____
 b. _____

CHAPTER 2, FORM C

Graph each relation.

11. $f(x) = \frac{1}{2}|x+1| - 2$

11.

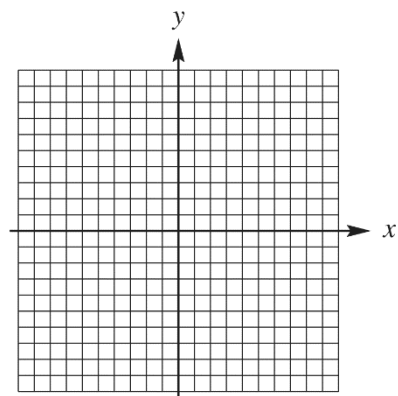

12. $f(x) = \lfloor 2x \rfloor - 2$

12.

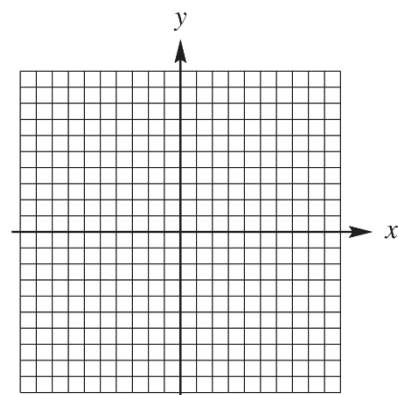

13. $f(x) = \begin{cases} x+1 & \text{if } x \leq -2 \\ -1 & \text{if } x > -2 \end{cases}$

13.

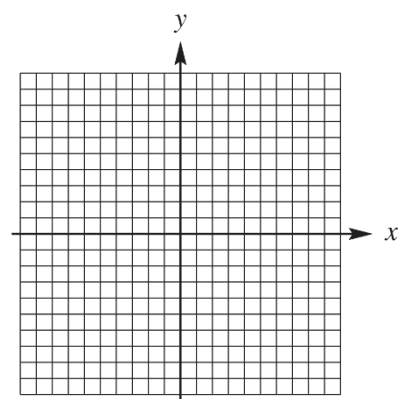

CHAPTER 2, FORM C

14. Explain how the graph of $y = 3|x + 4| + 2$ can be obtained from the graph of $y = |x|$. 14. _____

15. Determine whether the graph of $y = 3x^2 + 7$ is symmetric with respect to 15. a. _____

a. the x -axis, b. _____

b. the y -axis, c. _____

c. the origin.

Given $f(x) = 3x^2 - 2$ and $g(x) = 4x + 4$, find each of the following. Simplify the expressions when possible.

16. $(fg)(x)$ 16. _____

17. $(g - f)(x)$ 17. _____

18. $f(-2)$ 18. _____

19. $\frac{f(x+h) - f(x)}{h}$ 19. _____

20. $(f + g)(0)$ 20. _____

21. $\left(\frac{f}{g}\right)(-2)$ 21. _____

22. $(f - g)(x)$ 22. _____

23. $(f \circ g)(x)$ 23. _____

24. $(g \circ f)(x)$ 24. _____

25. $(g \circ f)(0)$ 25. _____

CHAPTER 2, FORM D
COLLEGE ALGEBRA AND TRIGONOMETRY

NAME _____
 DATE _____

1. Match the set described in Column I with the correct interval notation from Column II. Choices in Column II may be used once, more than once, or not at all.

I	II
a. Domain of $f(x) = \sqrt{x+1}$	A. $(-\infty, -1]$
b. Range of $f(x) = \sqrt{x+1}$	B. $(-\infty, \infty)$
c. Domain of $f(x) = x^2 - 25$	C. $[0, 2]$
d. Range of $f(x) = x^2 - 1$	D. $[0, \infty)$
e. Domain of $f(x) = \sqrt[3]{x-2}$	E. $[-3, 3]$
f. Range of $f(x) = \sqrt[3]{x+2}$	F. $[-3, \infty)$
g. Domain of $f(x) = x+4 $	G. $[-1, \infty)$
h. Range of $f(x) = x -4$	H. $[-4, \infty)$
i. Domain of $y = 2x^2$	
j. Range of $y = x^2 - 4$	

1. a. _____
 b. _____
 c. _____
 d. _____
 e. _____
 f. _____
 g. _____
 h. _____
 i. _____
 j. _____

The graph shows the line that passes through the points $(-7, -4)$ and $(3, -2)$. Refer to it to answer Exercises 2–6.

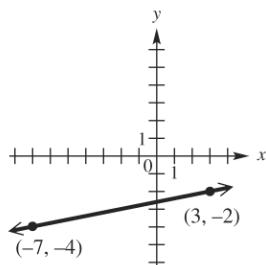

- | | |
|--|----------|
| 2. What is the slope of the line? | 2. _____ |
| 3. What is the distance between the two points shown? | 3. _____ |
| 4. What are the coordinates of the midpoint of the segment joining the two points? | 4. _____ |
| 5. Find the standard form of the equation of the line. | 5. _____ |
| 6. Write the linear function defined by $f(x) = ax + b$ that has this line as its graph. | 6. _____ |

CHAPTER 2, FORM D

Tell whether each graph is that of a function. Give the domain and the range. If it is a function, give the intervals where it is increasing, decreasing, or constant.

7.

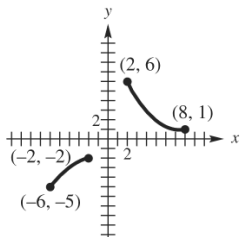

7. _____

8.

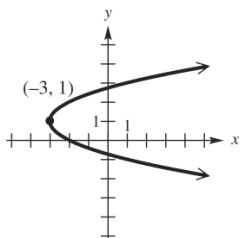

8. _____

Graph each relation.

9. $f(x) = 3 + |x + 1|$

9.

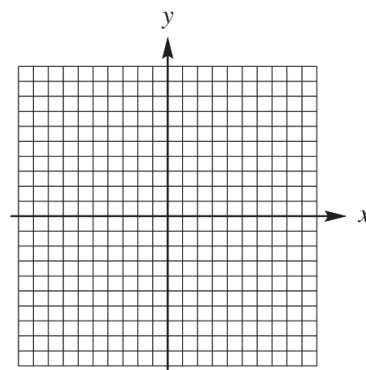

10. $f(x) = \begin{cases} -x & \text{if } x < 0 \\ 2x & \text{if } x \geq 0 \end{cases}$

10.

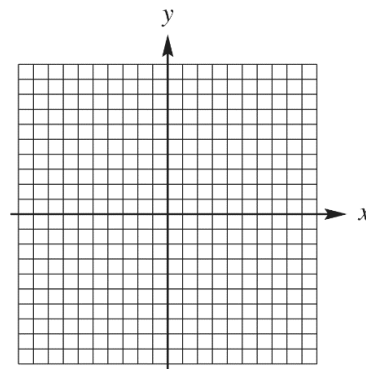

CHAPTER 2, FORM D

11. Suppose point P has coordinates $(-3, 2.1)$.
- a. What is the equation of the vertical line through P ? **11. a.** _____
- b. What is the equation of the horizontal line through P ? **b.** _____
12. Find the slope-intercept form of the equation of the line passing through $(1, -5)$ and
- a. parallel to the graph of $x = -\frac{3}{4}y + 5$; **12. a.** _____
- b. perpendicular to the graph of $x = -\frac{3}{4}y + 5$; **b.** _____
13. Find the slope of the line through points $(11, -5)$ and $(-8, 6)$. **13.** _____
from the graph of $y = \sqrt{x}$.
14. Explain how the graph of $y = 3\sqrt{x-4} - 2$ can be obtained **14.** _____
from the graph of $y = \sqrt{x}$.
15. Determine whether the graph of $xy = -4$ is symmetric **15. a.** _____
with respect to **b.** _____
- a. the x -axis, **c.** _____
- b. the y -axis,
- c. the origin.

Given $f(x) = 2x^3 - 3x - 1$ and $g(x) = 2x + 1$, find each of the following. Simplify the expressions when possible.

16. $(f + g)(x)$ **16.** _____
17. $\left(\frac{f}{g}\right)(x)$ **17.** _____
18. $f(0)$ **18.** _____
19. $\frac{f(x+h) - f(x)}{h}$ **19.** _____
20. $(g - f)(0)$ **20.** _____
21. $(fg)(-1)$ **21.** _____
22. $(f \circ g)(x)$ **22.** _____

CHAPTER 2, FORM D

23. $(f \circ g)(2)$

24. $(g \circ f)(x)$

25. $(g \circ f)(2)$

23. _____

24. _____

25. _____

CHAPTER 2, FORM E
COLLEGE ALGEBRA AND TRIGONOMETRY

NAME _____
 DATE _____

Choose the best answer.

- 1a.** Which of the following is the domain of $f(x) = \sqrt{3-x}$? **1a.** _____
- a. $[0, 3]$ b. $(-\infty, 3]$
 c. $[3, \infty)$ d. $(-\infty, \infty)$
- 1b.** Which of the following is the range of $f(x) = x^2 - 49$? **1b.** _____
- a. $[-49, \infty)$ b. $[-7, \infty)$
 c. $[-7, 7]$ d. $[0, \infty)$
- 1c.** Which of the following is the domain of $f(x) = \sqrt[3]{x+7}$? **1c.** _____
- a. $(-\infty, \infty)$ b. $(-\infty, 6]$
 c. $[0, \infty)$ d. $[6, \infty)$
- 1d.** Which of the following is the range of $f(x) = |x| + 1$? **1d.** _____
- a. $[-1, 1]$ b. $[0, 1]$
 c. $[0, \infty)$ d. $[1, \infty)$
- 1e.** Which of the following is the domain of $x = y^2$? **1e.** _____
- a. $(-\infty, \infty)$ b. $[0, \infty)$
 c. $(0, \infty)$ d. $(-\infty, 0]$

The graph shows the line that passes through $(-5, 8)$ and $(4, -3)$. Refer to it to answer Exercises 2-6.

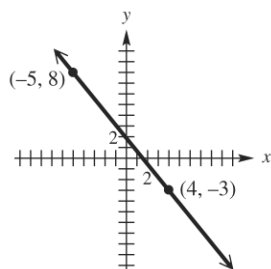

- 2.** What is the slope of the line? **2.** _____
- a. $-\frac{13}{7}$ b. $\frac{11}{9}$
 c. $-\frac{11}{9}$ d. 0
- 3.** What is the distance between the two points shown? **3.** _____
- a. $\sqrt{26}$ b. $2\sqrt{5}$
 c. $\sqrt{202}$ d. $\sqrt{122}$

CHAPTER 2, FORM E

4. What are the coordinates of the midpoint of the segment joining the two points?

a. $\left(-\frac{1}{2}, \frac{5}{2}\right)$ b. $\left(-\frac{9}{2}, \frac{11}{2}\right)$
 c. $\left(\frac{3}{2}, \frac{1}{2}\right)$ d. $(-1, 5)$

4. _____

5. Find the standard form of the equation of the line.

a. $11x + 9y = 127$ b. $11x - 9y = 17$
 c. $11x + 9y = 17$ d. $11x - 9y = 127$

5. _____

6. Find the standard form of the equation of the line.

a. $f(x) = \frac{11}{9}x - \frac{17}{9}$ b. $f(x) = -\frac{11}{9}x + \frac{17}{9}$
 c. $f(x) = \frac{11}{9}x + \frac{127}{9}$ d. $f(x) = \frac{11}{9}x - \frac{127}{9}$

6. _____

Tell whether each graph is that of a function. Give the domain and range.

7.

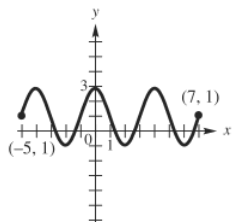

7. _____

- a. Function; domain: $[-5, 7]$; range: $[-1, 3]$
 b. Function; domain: $(-\infty, \infty)$; range: $[-1, 3]$
 c. Function; domain: $[-1, 3]$; range: $[-5, 7]$
 d. Not a function; domain: $[-5, 7]$; range: $[-1, 3]$

8.

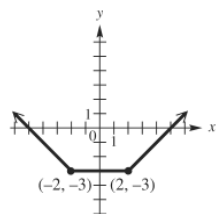

8. _____

- a. Not a function; domain: $(-\infty, \infty)$; range: $[-2, \infty)$
 b. Not a function; domain: $[-5, 5]$; range: $[-3, \infty)$
 c. Function; domain: $(-\infty, \infty)$; range: $[-2, \infty)$
 d. Function; domain: $(-\infty, \infty)$; range: $[-3, \infty)$

CHAPTER 2, FORM E

9. Suppose point P has coordinates $(-6, 1)$.

What is the equation of the horizontal line through P ?

- a. $x = -6$ b. $y = 1$
 c. $x = 1$ d. $y = 6$

9. _____

10. Find the slope-intercept form of the equation of the line passing.

through $(-2, 5)$ perpendicular to the graph of $y = -\frac{1}{8}x + \frac{19}{4}$.

- a. $y = 8x + 21$ b. $y = \frac{1}{3}x - 3$
 c. $y = -8x - 13$ d. $y = -\frac{1}{3}x + 3$

10. _____

Graph each function.

11. $f(x) = 2|x - 1| - 2$

11. _____

a.

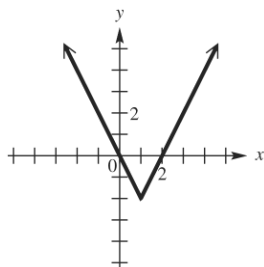

b.

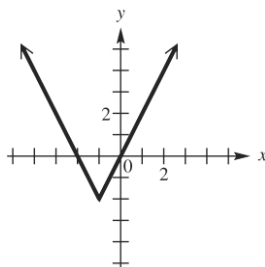

c.

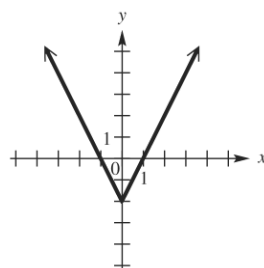

d.

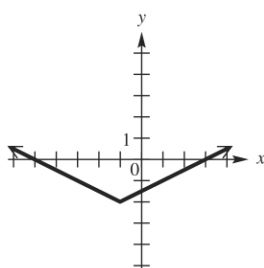

CHAPTER 2, FORM E

12. $f(x) = \begin{cases} \frac{1}{2}x & x < 1 \\ \frac{1}{2} & x \geq 1 \end{cases}$

12. _____

a.

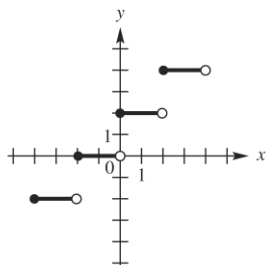

b.

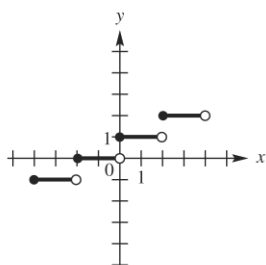

c.

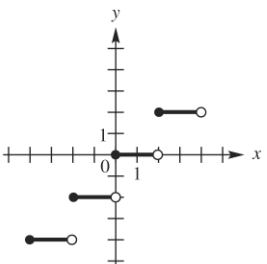

d.

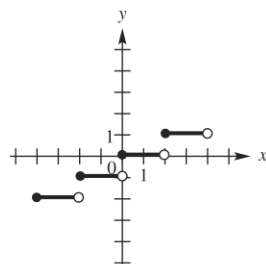

13. $f(x) = \begin{cases} 2 & \text{if } x < -2 \\ -\frac{1}{2}x + 1 & \text{if } x \geq -2 \end{cases}$

13. _____

a.

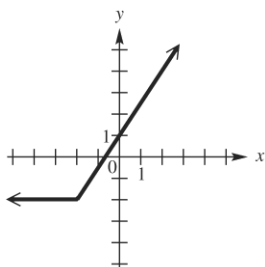

b.

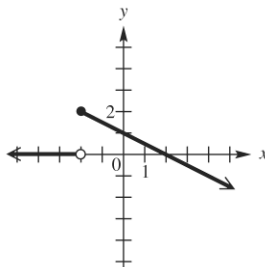

c.

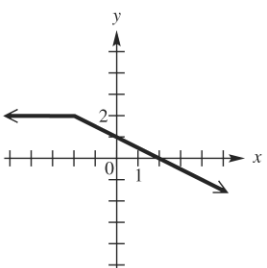

d.

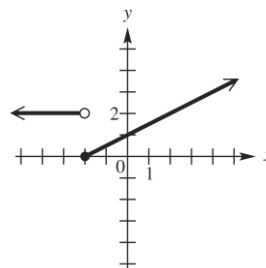

CHAPTER 2, FORM E

14. Explain how the graph of $y = \sqrt{x+2} - 5$ can be obtained from the graph of $y = \sqrt{x}$. 14. _____
- Translate 2 unit to the right and 5 units up.
 - Translate 2 unit to the right and 5 units down.
 - Translate 2 unit to the left and 5 units up.
 - Translate 2 unit to the left and 5 units down.

15. Determine the symmetries of the graph of the relation $x^2 - 2xy + y^2 = 5$. 15. _____
- x -axis only
 - y -axis only
 - origin only
 - x -axis, y -axis, and origin

Given $f(x) = 5x - 4$ and $g(x) = x^2 + 3$, find each of the following.
Simplify the expressions when possible.

16. $(fg)(x)$ 16. _____
- $x^3 + 4x^2 - 12$
 - $5x^3 - 4x^2 + 15x - 12$
 - $5x^3 + 4x^2 + 3x - 12$
 - $-5x^3 + 4x^2 - 5x - 12$

17. $(g - f)(x)$ 17. _____
- $x^2 - 5x + 7$
 - $x^2 + 5x - 7$
 - $-x^2 - 5x + 1$
 - $x^2 + 5x + 1$

18. The domain of $\frac{g}{f}$ 18. _____
- $\left(-\infty, \frac{4}{5}\right) \cup \left(\frac{4}{5}, \infty\right)$
 - $\left(-\infty, \frac{5}{4}\right) \cup \left(\frac{5}{4}, \infty\right)$
 - $\left(-\infty, \frac{1}{3}\right) \cup \left(\frac{1}{3}, \infty\right)$
 - $(-\infty, \infty)$

19. $\frac{f(x+h) - f(x)}{h}$ 19. _____
- h
 - 5
 - $5x + 2h$
 - $5x + 2h - 4$

20. $(f + g)(-1)$ 20. _____
- 1
 - 5
 - 2
 - 5

CHAPTER 2, FORM E

21. $\left(\frac{f}{g}\right)(0)$ 21. _____
- a. $-\frac{3}{4}$ b. $\frac{1}{4}$
- c. $-\frac{4}{3}$ d. $\frac{15}{2}$
22. $(g \circ f)(x)$ 22. _____
- a. $25x^2 + 40x - 19$ b. $25x^2 - 40x + 19$
- c. $25x^2 - 40x - 19$ d. $25x^2 + 40x + 19$
23. $(g \circ f)(1)$ 23. _____
- a. -6 b. 4
- c. 0 d. 1
24. $(f \circ g)(x)$ 24. _____
- a. $5x^2 - 11$ b. $5x^2 + 11$
- c. $5x^2 + 19$ d. $5x^2 - 12$
25. $(f \circ g)(0)$ 25. _____
- a. -1 b. 0
- c. 11 d. 15

CHAPTER 2, FORM F
COLLEGE ALGEBRA AND TRIGONOMETRY

NAME _____
 DATE _____

Choose the best answer.

- 1a.** Which of the following is the domain of $f(x) = \sqrt{x-1}$? **1a.** _____
- a. $[0,1]$ b. $(-\infty,1]$
 c. $[1,\infty)$ d. $(-\infty,\infty)$
- 1b.** Which of the following is the range of $f(x) = x^2 - 4$? **1b.** _____
- a. $[-2,\infty)$ b. $[-4,\infty)$
 c. $[-4,4]$ d. $[0,\infty)$
- 1c.** Which of the following is the domain of $f(x) = \sqrt[3]{x-7}$? **1c.** _____
- a. $(-\infty,\infty)$ b. $(-\infty,3]$
 c. $[0,\infty)$ d. $[3,\infty)$
- 1d.** Which of the following is the range of $f(x) = |x| + 2$? **1d.** _____
- a. $[-2,2]$ b. $[0,2]$
 c. $[2,\infty)$ d. $[0,\infty)$
- 1e.** Which of the following is the domain of $x = y^2$? **1e.** _____
- a. $(-\infty,\infty)$ b. $[0,\infty)$
 c. $(0,\infty)$ d. $(-\infty,0]$

The graph shows the line that passes through $(-7, -4)$ and $(3, -2)$. Refer to it to answer Exercises 2-6.

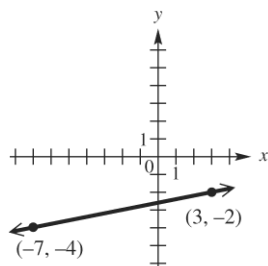

- 2.** What is the slope of the line? **2.** _____
- a. 0 b. $-\frac{1}{5}$
 c. $\frac{1}{5}$ d. 5
- 3.** What is the distance between the two points shown? **3.** _____
- a. $\sqrt{122}$ b. $2\sqrt{26}$
 c. $2\sqrt{13}$ d. $2\sqrt{34}$

CHAPTER 2, FORM F

4. What are the coordinates of the midpoint of the *segment* joining the two points?

- a. $\left(\frac{1}{2}, -\frac{11}{2}\right)$ b. $(-2, -1)$
 c. $(-5, -1)$ d. $(-2, -3)$

4. _____

5. Find the standard form of the equation of the line.

- a. $5x - y = 17$ b. $5x + y = -17$
 c. $x - 5y = 13$ d. $x + 5y = -13$

5. _____

6. Find the standard form of the equation of the line.

- a. $f(x) = \frac{1}{5}x - \frac{13}{5}$ b. $f(x) = -5x + 17$
 c. $f(x) = 5x - 17$ d. $f(x) = \frac{1}{5}x + \frac{13}{5}$

6. _____

Tell whether each graph is that of a function. Give the domain and range.

7.

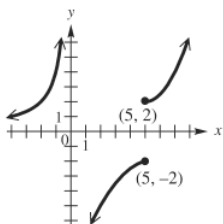

7. _____

- a. not a function; domain: $(-\infty, 0) \cup (0, \infty)$; range: $(-\infty, -2] \cup (0, \infty)$
 b. not a function; domain: $(-\infty, \infty)$; range: $(-\infty, \infty)$
 c. not a function; domain: $(-\infty, 0) \cup (0, \infty)$; range: $(-\infty, \infty)$
 d. not a function; domain: $(-\infty, 0) \cup (0, \infty)$; range: $(-\infty, -2] \cup (2, \infty)$

8.

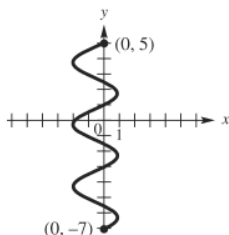

8. _____

- a. not a function; domain: $[-2, 1]$; range: $(-\infty, \infty)$
 b. not a function; domain: $[-7, 5]$; range: $[-2, 1]$
 c. not a function; domain: $[-7, 5]$; range: $(-\infty, \infty)$
 d. not a function; domain: $[-2, 1]$; range: $[-7, 5]$

CHAPTER 2, FORM F

9. Suppose point P has coordinates $(-3, 6)$.

What is the equation of the horizontal line through P ?

- a. $x = -3$ b. $y = -3$
 c. $x = 6$ d. $y = 6$

9. _____

10. Find the slope-intercept form of the equation of the line passing.

through $(1, 2)$ perpendicular to the graph of $y = -\frac{1}{8}x + \frac{1}{3}$.

- a. $y = 8x - 3$ b. $y = \frac{1}{8}x - \frac{1}{3}$
 c. $y = -8x + 3$ d. $y = -\frac{1}{8}x + \frac{17}{8}$

10. _____

Graph each relation.

11. $f(x) = \frac{1}{2}|x+1|$

11. _____

a.

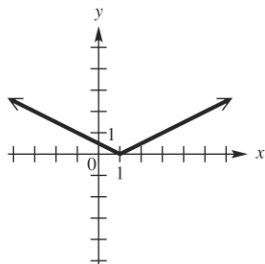

b.

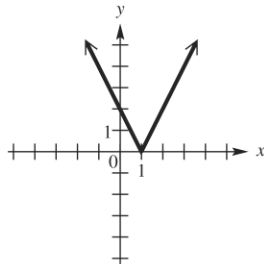

c.

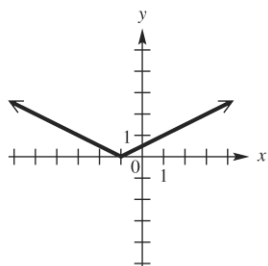

d.

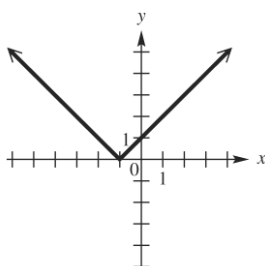

CHAPTER 2, FORM F

12. $f(x) = \begin{cases} \frac{1}{2}x - 2 & x < 1 \\ \frac{1}{2}x & x \geq 1 \end{cases}$

12. _____

a.

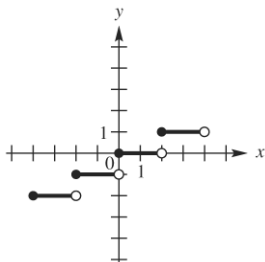

b.

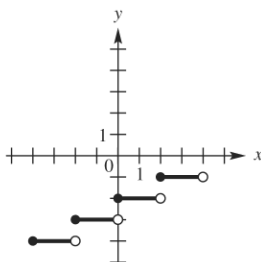

c.

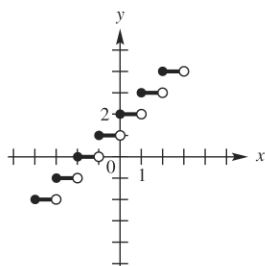

d.

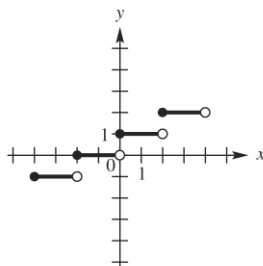

13. $f(x) = \begin{cases} -2x & \text{if } x < -1 \\ x+3 & \text{if } x \geq -1 \end{cases}$

13. _____

a.

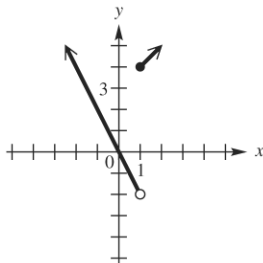

b.

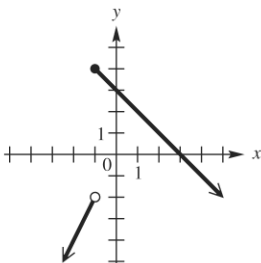

c.

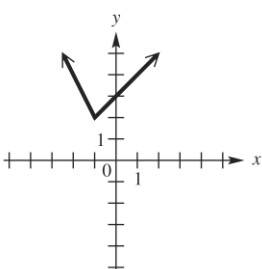

d.

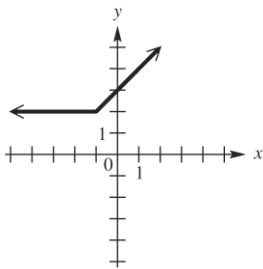

14. Explain how the graph of $y = \sqrt{x+3} + 1$ can be obtained from the graph of $y = \sqrt{x}$.

14. _____

- Translate 3 units to the right and 1 units up.
- Translate 3 units to the right and 1 units down.
- Translate 3 units to the left and 1 units up.
- Translate 3 units to the left and 1 units down.

CHAPTER 2, FORM F

15. Determine the symmetries of the graph of the relation $4x^2 + 9y^2 = 36$.

- a. x -axis only b. y -axis only
 c. Origin only d. x -axis, y -axis, and origin

15. _____

Given $f(x) = 6x^2 + 5x - 6$ and $g(x) = 2x - 8$, find each of the following.
 Simplify the expressions when possible.

16. $f(-3)$

- a. -9 b. 21
 c. 33 d. 51

16. _____

17. $\frac{f(x+h) - f(x)}{h}$

- a. $12x + 6h + 5$ b. $12x - 6h - 5$
 c. $-12x + 6h + 5$ d. $-12x + 6h - 5$

17. _____

18. $(f \circ g)\left(\frac{3}{2}\right)$

- a. -131 b. 119
 c. -181 d. 169

18. _____

19. $(f + g)(x)$

- a. $6x^2 + 7x - 14$ b. $6x^2 - 7x - 14$
 c. $6x^2 + 7x - 2$ d. $6x^2 - 3x - 2$

19. _____

20. $(f + g)(0)$

- a. -15 b. -14
 c. -27 d. 1

20. _____