

CHAPTER 1

1.1

The basic strategy of the room air-conditioner can be described as follows:

1. Measure the temperature in a room by means of a "thermostat", which is nothing more than a sensor of temperature. Thus temperature is the controlled variable.

2. The measured temperature is compared to a setpoint in the thermostat. Often this is simply a bimetal strip which closes a contact when the temperature exceeds some limit.

3. If the temperature is too low then the compressor and distribution fan of the air-conditioner are turned on. This causes room air to be circulated through the unit and thereby cooled and exhausted back into the room. Therefore you can see that the manipulated variable is the temperature of the recirculated air.

The system is self-regulating because even without operation of the air-conditioner, the room will adopt some temperature in equilibrium with the outside air, open windows/doors, cooking, etc., etc.

1.2

Driving a car is a servomechanism because the objective is to control the motion of the vehicle rather than to regulate a specific value. Therefore the objective is to cause the vehicle to follow a prescribed path. Of course keeping the speed constant during a trip could be considered process control since the speed is being regulated.

1.3

The refrigerator is a classical example of a process control system. The controlled variable is the temperature of the air in the refrigerator and the controlling variable is the pumping of air across the cooled coils of the evaporator coils. The setpoint is determined by the "coldness" setting of a knob in the unit. The following statements describes the refrigerator.

(a) measurement: A sensor in the refrigerator to measure ambient internal temperature. This may be a gas bulb type where pressure determines the temperature or an electronic type.

(b) setpoint: Determined by a knob setting.

(c) error detector/controller: This will typically be a relay to turn on the compressor/fan driven by gas pressure or an electrical signal. Deadband is provided to prevent excessive cycling.

(d) process: This is of course the refrigerator and all its contents.

(e) final control element: The compressor may be thought of as the final control element although one may argue the evaporator coils and circulation fan do the actual action on the process.

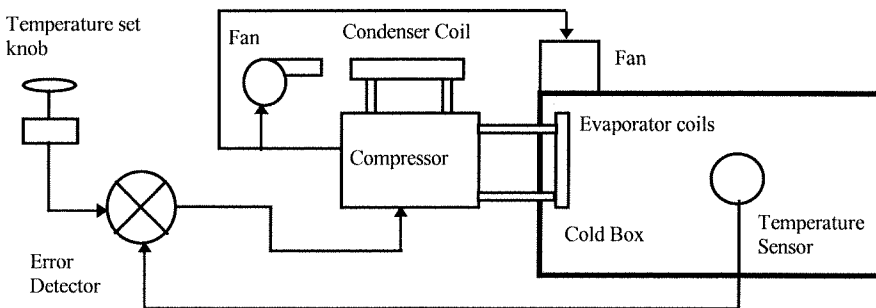

1.4

(a) maximum error = peak error - setpoint = $197\text{ }^{\circ}\text{C} - 175\text{ }^{\circ}\text{C} = 22\text{ }^{\circ}\text{C}$

(b) settling time = time of first excursion beyond $175 \pm 5\text{ }^{\circ}\text{C}$ to the time that range is re-acquired.

= $9.8\text{ s} - 1.4\text{ s}$

= 8.4 s

(c) residual error = error remaining after the transient has finished.

$\approx 1\text{ }^{\circ}\text{C}$

1.5

The area of the two curves can be approximated by the areas of rectangles as:

The absolute magnitudes of the rectangular areas are summed to give:

(a) Area = 6 units

(b) Area = 9 units

Therefore response (a) has the minimum area.

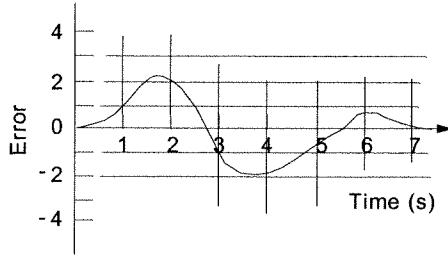

(a)

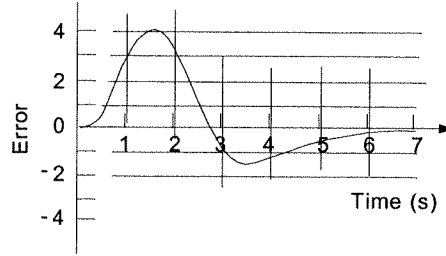

(b)

1.6

Since each peak must be a quarter of the previous the next peak must be given by:

$$a_3 = (1/4)a_2$$

$$a_3 = (1/4)(4.4\%) = 1.1\%$$

1.7

Consider the following analysis:

The 1st peak error = $197.5 - 175 = 22.5$.

One quarter of this is 5.6 but the actual peak is 7 .

The third peak should be about 1.75 but is 2 . The conclusion is that the tuning does not match quarter-amplitude exactly since each peak is higher than that predicted by the criteria.

1.8

Since it is linear we can calculate the current for each m^3/hr of flow rate, as: $(50 \text{ mA})/(300 \text{ m}^3/hr) = 1/6 \text{ mA per m}^3/hr$ so, for $225 \text{ m}^3/hr$, the current will be

$$I = (225 \text{ m}^3/hr)(1/6 \text{ mA}/(\text{m}^3/hr)) \quad I = 37.5 \text{ mA}$$

1.9

$$14_{10} = 1110_2$$

1.10

We can make a table of changes for the 16 states of the 4-bit ADC

Binary	Level	Binary	Level
0000	0	1001	1.35
0001	0.15	1010	1.50
0010	0.30	1011	1.65
0011	0.45	1100	1.80
0100	0.60	1101	1.95
0101	0.75	1110	2.10
0110	0.90	1111	2.25
0111	1.05		
1000	1.20		

So we see that a level of 1.7 m would result in an output of 1011_2 , since the level is greater than 1.65 but not yet 1.8 for the next bit change. If the bits were 1000_2 then the MOST that can be said is that the level is between 1.20 m and 1.35 m . Thus there is an uncertainty of 0.15 m .

1.11

Well, first of all there are $0.15 \text{ V}/^\circ\text{C}$ produced by the measurement, so the output of the measurement is $0.15T \text{ V}$. Second, the differential amplifier will subtract 3 V (the setpoint) and then amplify the result by 10 (ten). Thus the input to the diodes and the relays is:

$$V_D = 10(0.15T - 3)$$

or, solving for T , since that is what we want to find,

$$T = (3 + V_D/10)/0.15$$

If we assume ideal diodes with no forward voltage drop, then the temperatures can be found from the above equation by setting V_D equal to $+1.5 \text{ V}$, $+1.1 \text{ V}$, -1.1 V , and -1.5 V and solving for T in each case.

- +1.5 V: cooler on, $T = (3 + 1.5/10)/.15 = 21 \text{ }^\circ\text{C}$
- +1.1 V: cooler off, $T = (3 + 1.1/10)/.15 = 20.7 \text{ }^\circ\text{C}$
- 1.1 V: heater off, $T = (3 - 1.1/10)/.15 = 19.3 \text{ }^\circ\text{C}$
- 1.5 V: heater on, $T = (3 - 1.5/10)/.15 = 19 \text{ }^\circ\text{C}$

1.12 For Supervisory Control:

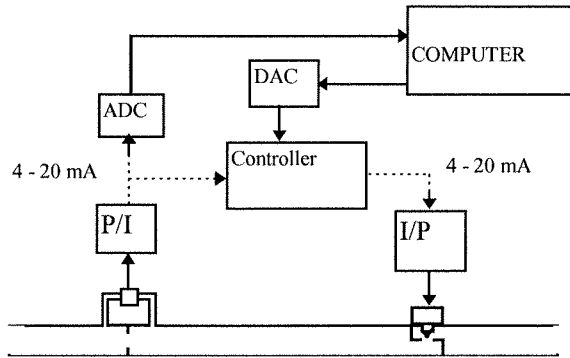

For Computer Control:

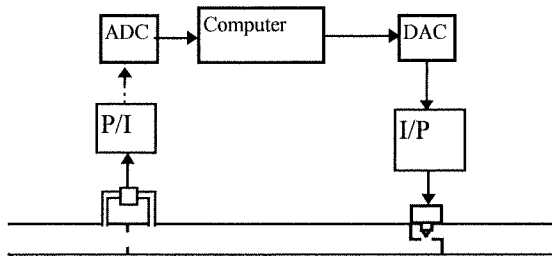

1.13

First of all we need a manual valve on the cold water, a temperature sensor on the mixed hot and cold water and a temperature readout. Then on the hot water side we need a control system to regulate the hot water valve. The system block diagram for analog and digital control is shown in the following diagrams: (a) analog

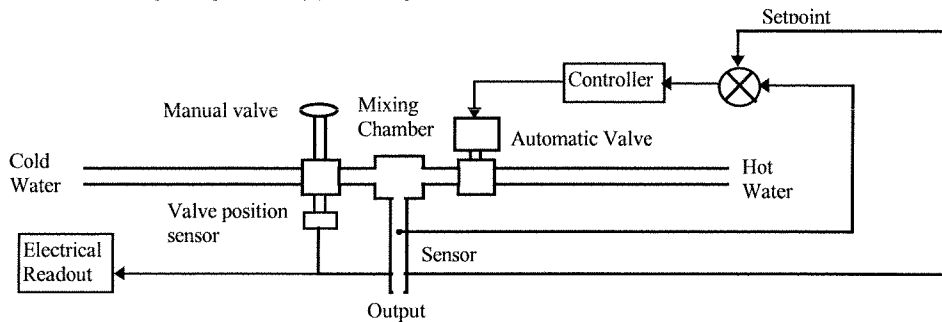

Computer Control:

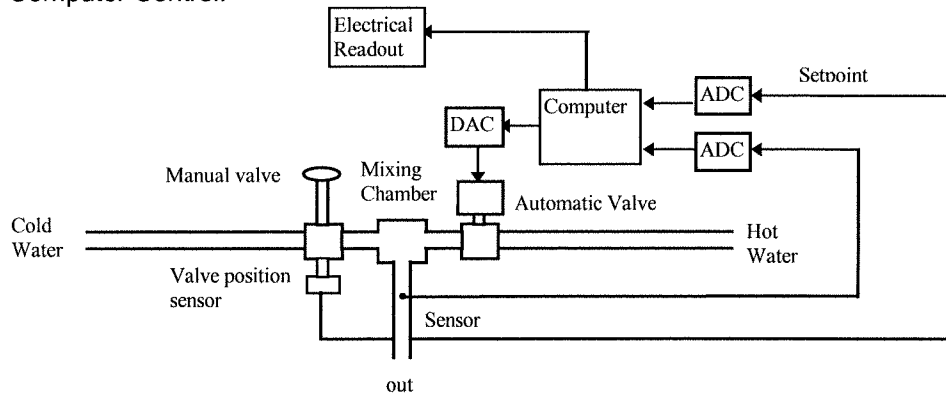

1.14

(For example) I weigh about 170 lb, so this is

$$(170 \text{ lb})(0.454 \text{ kg/lb}) = 77.2 \text{ kg}$$

I am 5 feet 11 inches tall so let's first convert to inches and then multiply by the SI conversion factor

$$(5 \times 12 + 11)(0.0254 \text{ in/m}) = 1.8 \text{ m}$$

1.15

$$\begin{aligned} \rho_{at} &= (14.7 \text{ psi}) / (1.45 \times 10^{-4} \text{ psi/Pa}) \\ &= 101,379 \text{ Pa} \end{aligned}$$

1.16

1 mile = 5280 ft and 1 ft = 0.3048 m

(a) for the acceleration we find,

$$a = 2x/t^2 = (2)(.25 \text{ mile})(5280 \text{ ft/mile}) / (7.2^2) \quad a = 50.93 \text{ ft/s}^2$$

(b) in m/s^2 we have $a = (50.93 \text{ ft/s}^2)(0.3048 \text{ m/ft}) = 15.5 \text{ m/s}^2$

(c) we have velocity, $v = 2ax$ so,

$$v = (2)(15.5 \text{ m/s}^2)(.25 \text{ mile})(5280 \text{ ft/mile})(.3048 \text{ m/ft}) \quad v = 111.7 \text{ m/s}$$

(d) The weight must be converted to mass in kg,

$$m = (2000 \text{ lb})(0.454 \text{ kg/lb}) = 908 \text{ kg}$$

now,

$$\begin{aligned} W &= (908 \text{ kg})(111.7 \text{ m/s})^2 / 2 \\ W &= 5.67 \times 10^6 \text{ kg}\cdot\text{m}^2/\text{s}^2 = 5.67 \times 10^6 \text{ J} \end{aligned}$$

1.17

We can form a linear equation relating level and pressure,

$$p = mL + p_0$$

The slope, m, and intercept can be found from the two conditions,

$$3 \text{ psi} = (5.5 \text{ m})m + p_0$$

$$15 \text{ psi} = (8.6 \text{ m})m + p_0$$

subtracting the 1st from the second gives,

$$m = (15 - 3) / (8.6 - 5.5) \text{ psi/m} = 3.87 \text{ psi/m}$$

Then the intercept can be found as $p_0 = 3 \text{ psi} - (5.5 \text{ m})(3.87 \text{ psi/m}) = -18.29$

Thus the relation is,

$$p = 3.87L - 18.29$$

Now, a level of 7.2 m gives, $p = 3.8(7.2) - 18.29 = 9.57 \text{ psi}$

and a pressure of 4.7 means, $4.7 = 3.87L - 18.29$. Solving for L gives $L = 5.94 \text{ m}$.

1.18

For a current of 12 mA we have a flow given by,

$$Q = 45[12 \text{ mA} - 2 \text{ mA}]^{1/2} = 142.3 \text{ gal/min}$$

If the flow is 162 gal/min we can form an equation,

$$162 = 45[I - 2 \text{ mA}]^{1/2}$$

solving for I we find,

$$I = (162/45)^2 + 2 = 14.96 \text{ mA}$$

1.19

$\pm 0.5\%$ FS for 0 to 1500 Ω means $(\pm 0.005)(1500) = \pm 7.5 \Omega$. Thus a measurement of 397 Ω actually means $397 \pm 7.5 \Omega$ or from 389.5 Ω to 404.5 Ω .

1.20

Well, 0.5 mV/ $^{\circ}\text{C}$ with a $\pm 1\%$ accuracy means the transfer function could be $0.5 \pm 0.005 \text{ mV}/^{\circ}\text{C}$ or 0.495 to 0.505 mV/ $^{\circ}\text{C}$. If the temperature were 60 $^{\circ}\text{C}$ the output would be in the range, $(0.495 \text{ mV}/^{\circ}\text{C})(60^{\circ}\text{C}) = 29.7 \text{ mV}$ to $(0.505 \text{ mV}/^{\circ}\text{C})(60^{\circ}\text{C}) = 30.3 \text{ mV}$ or $30 \pm 0.3 \text{ mV}$. Which is, of course, $\pm 1\%$.

1.21

We can express the three uncertainties in the fractional form as:

$$0.5 \pm 1\% \text{ mV}/^{\circ}\text{C} = 0.5(1 \pm 0.005/0.5) \text{ mV}/^{\circ}\text{C} \quad 15 \pm 0.25 \text{ gain} = 15(1 \pm .25/15) \text{ gain}$$

$$V \pm 1\% \text{ FS volts} = V(1 \pm 0.03/2) \text{ volts}$$

The worst case uncertainty would come from simply summing the three above:

$$\begin{aligned} \text{Worst Case} &= \pm (0.005/0.5 + 0.25/15 + 0.03/2) \\ &= \pm 4.2\% \end{aligned}$$

The rms computation is probably a more realistic value. It is found as:

$$\text{RMS} = [(0.005/0.5)^2 + (0.25/15)^2 + (0.03/2)^2]^{1/2} = \pm 2.5\%$$

1.22

Using the nominal values means that the transfer function from temperature to voltage is given by:

$$V = (0.5 \text{ mV}/^{\circ}\text{C})(15)T = 0.0075T$$

Now, the maximum measurable voltage is two, so the temperature is found from:

$$\begin{aligned} T_{\text{max}} &= V_{\text{max}}/0.0075 = 2.0/0.0075 \\ &= 266.7^{\circ}\text{C} \end{aligned}$$

1.23

This is a linear transducer so it is represented by the equation of a straight line with a zero intercept, so $V = KT$ with $K = 44.5 \text{ mV}/^{\circ}\text{C}$,

$$V = 0.0445T$$

If $V = 8.86$ volts then, $T = V/K = 8.86/0.0445 = 199.1011236^{\circ}\text{C}$

but we have only three significant figures, so the temperature is reported as,

$$T = 199^{\circ}\text{C}$$

1.24

This is a linear transformation, so we expect the equation of a straight line to relate the two variables,

$$P = KL + P_0$$

We have been given two facts about the variables so we can set up two equations in two unknowns, K and P_0 ,

$$3 \text{ psi} = K(4.50 \text{ ft}) + P_0$$

$$15 \text{ psi} = K(10.6 \text{ ft}) + P_0$$

subtracting the first equation from the second gives, $12 \text{ psi} = K(6.10 \text{ ft})$, so to three significant figures, $K = 1.97 \text{ psi/ft}$

Now, this is used in the first equation to find,

$$P_0 = 3 \text{ psi} - (1.97 \text{ psi/ft})(4.50 \text{ ft})$$

$$P_0 = -5.87 \text{ psi}$$

Thus the equation is,

$$P = 1.97L - 5.87$$

A level of 9.2 ft gives,

$$P = (1.97)(9.2) - 5.87$$

$$P = 12.3 \text{ psi}$$

1.25

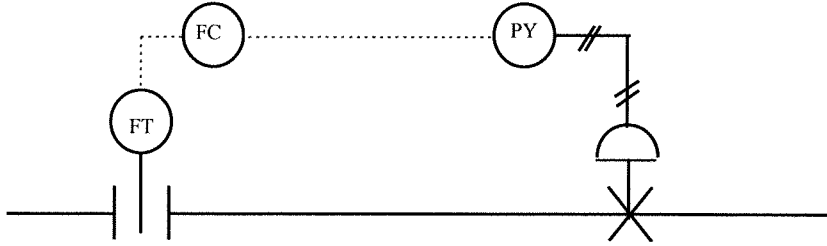

1.26

We do not have to use the transfer function at all since the relation between voltage and temperature is linear. Using the equation for first-order time response,

$$T = T_i + (T_f - T_i)(1 - e^{-t/\tau})$$

$$T = 22^\circ\text{C} + (50^\circ\text{C} - 22^\circ\text{C})(1 - e^{-t/3.3\text{ s}}) \quad T = 22 + 28(1 - e^{-t/3.3})^\circ\text{C}$$

$$t = 0.5\text{ s}; T = 22 + 28(1 - e^{-0.5/3.3}) = 22 + 28(1 - 0.8594) \quad T = 25.9^\circ\text{C}$$

$$t = 2.0\text{ s}; T = 22 + 28(1 - e^{-2/3.3}) = 34.7^\circ\text{C}$$

$$t = 3.3\text{ s}; T = 22 + 28(1 - e^{-3.3/3.3}) = 39.7^\circ\text{C}$$

$$t = 9.0\text{ s}; T = 22 + 28(1 - e^{-9/3.3}) = 48.2^\circ\text{C}$$

1.27

Using the first-order time response equation, we know everything except the time constant,

$$52 = 44 + (70 - 44)(1 - e^{-4.5/\tau})$$

$$8 = 26(1 - e^{-4.5/\tau})$$

$$e^{-4.5/\tau} = 1 - 8/26 = 0.6923$$

taking natural logarithms of both sides,

$$-4.5/\tau = \ln(0.6923) = -0.3677$$

$$\tau = 12.2\text{ s}$$

1.28

This is a first-order time response problem for light intensity. We have the relation,

$$I = I_i + (I_f - I_i)(1 - e^{-t/\tau})$$

When the indicated value is 80% it means that 80% of the total change will have occurred, i.e.,

$$(I - I_i) = 0.8(I_f - I_i)$$

Thus the equation becomes,

$$0.8 = 1 - e^{-t/0.035\text{ s}}, \text{ or}$$

$$0.2 = e^{-t/0.035}$$

Taking natural logarithms of both sides gives,

$$-1.609 = -t/0.035, \text{ so that,}$$

$$t = 56\text{ ms}$$

1.29

Ok, the question is how does the voltage vary with time and then when does it reach 4.00 volts?

Well, the first order time constant equation, for the voltage, will tell us.

First we need the initial and final values of voltage, which come from the static transfer function,

$$V_i = (20\text{ mV/kPa})(100\text{ kPa}) = 2.0\text{ volts}$$

$$V_f = (20\text{ mV/kPa})(400\text{ kPa}) = 8.0\text{ volts}$$

Now, the time at which the voltage reaches 4.0 volts is given by,

$$4.0 = 2.0 + (8.0 - 2.0)(1 - e^{-t/4.9})$$

$$2.0 = 6.0(1 - e^{-t/4.9})$$

$$e^{-t/4.9} = 0.6666, \text{ taking the natural log of both sides gives,}$$

$$-t/4.9 = \log_e(0.6666) = -0.4054$$

so

$$t = 1.99\text{ s}$$

1.30

The sensor response is linear but the signal conditioning converts this nonlinearly to a voltage. Thus there are three steps in converting a sudden change in pressure to a voltage. First the transfer function conversion of pressure to resistance, second the first order time response of the sensor and third the conversion of resistance to voltage. The pressure itself has only two values, initially 40 psi and finally (and instantaneously after $t = 0$) 150 psi. The initial and final resistance's are:

$$R_i = 0.15(40) + 2.5 \text{ k}\Omega = 8.5 \text{ k}\Omega$$

$$R_f = 0.15(150) + 2.5 \text{ k}\Omega = 25 \text{ k}\Omega$$

(a) at $t = 0.5$ seconds we find the resistance as,

$$R(0.5) = 8.5 + (25 - 8.5)[1 - e^{-0.5/0.35}] \text{ k}\Omega = 21 \text{ k}\Omega$$

so the output voltage is,

$$V(0.5) = (10)(21 \text{ k}\Omega)/(21 \text{ k}\Omega + 10 \text{ k}\Omega) = 6.77 \text{ V}$$

The indicated pressure is found from the sensor transfer function,

$$21 \text{ k}\Omega = 0.15p(\text{indicated}) + 2.5 \text{ k}\Omega$$

$$p(\text{indicated}) = 123 \text{ psi (but of course the pressure is actually 150 psi)}$$

(b) We must work back from the voltage. First we find the resistance,

$$R(t) = (10 \text{ k}\Omega)(5.0 \text{ V})/(10 \text{ V} - 5.0 \text{ V}) = 10 \text{ k}\Omega$$

Now we use the first order time response equation to find the time at which this resistance occurs,

$$10 \text{ k}\Omega = 8.5 + 16.5[1 - e^{-t/0.35}] \text{ k}\Omega$$

solving,

$$e^{-t/0.35} = 0.91$$

$$-t/0.35 = \ln(0.91) = -0.095$$

$$t = 0.033 \text{ s}$$

Note that we could not find the initial and final voltages and apply the first order time response equation directly to the voltage because of the nonlinear relation between resistance and voltage.

1.31

The initial and final sensor voltages are,

$$V_i = 0.06(25 - 20) = 0.3 \text{ V and } V_f = 0.06(100 - 20) = 4.8 \text{ V}$$

The first order time response equation is given by,

$$V(t) = 0.3 + (4.8 - 0.3)[1 - e^{-t/\tau}] = 0.3 + 4.5[1 - e^{-t/\tau}]$$

Solving for the time constant gives,

$$\tau = -t/[\ln(4.8 - V(t)) - \ln(4.5)]$$

Now the values of t can be computed for each given time and voltage,

t	$V(t)$	τ
0	0.3	0 (not a valid data point)
0.1	1.8	0.247
0.2	2.8	0.247
0.3	3.4	0.257
0.4	3.9	0.249
0.5	4.2	0.248

So the average for the time constant is $t_{\text{ave}} = 0.25 \text{ s}$

1.32

Hey, from Ohm's Law, $I = 4.7 \text{ V}/1.5 \text{ k}\Omega = 3.13333333 \text{ mA}$ as a "designed" or calculated value.

Now, if we measure 4.7 V and 1500 Ω then we report the current as, $I = 3.1 \text{ mA}$, because the 4.7 V has only two significant figures.

1.33

There are 17 values, if x_i represents the values of flow rate then the mean is found from,

$$\langle x \rangle = \sum x_i / N = 174.8/17$$

$$\langle x \rangle = 10.3 \text{ gal/min} \quad \text{The standard deviation is found from,}$$

$$\sigma = \sqrt{\sum (x_i - \langle x \rangle)^2 / (N-1)}$$

$$\sigma = 26.79/16$$

$$\sigma = 1.29 \text{ gal/min}$$

1.34

Initially the pressure is exactly 20 kPa and finally the pressure is exactly 100 kPa. The problem is that the static transfer function is uncertain by 5%, so the output voltage of the sensor will be uncertain by 5% also.

(a) Nominally the initial voltage will be $V_i = (45 \text{ mV/kPa})(20 \text{ kPa}) = 0.9 \text{ volts}$ and for the final voltage, $V_f = (45 \text{ mV/kPa})(100 \text{ kPa}) = 4.5 \text{ volts}$.

Because of the uncertainty in the transfer function the actual output voltages expected will be,

$$V_i = 0.9 \pm 5\% = 0.9 \pm 0.045 \text{ or } 0.855 \text{ to } 0.945 \text{ volts}$$

and

$$V_f = 4.5 \pm 5\% = 4.5 \pm 0.225 \text{ or } 4.275 \text{ to } 4.725 \text{ volts}$$

(b) After 2 seconds the voltage output will depend upon the first order time response, the uncertainties in initial and final voltages and the uncertainties in the time constant. The voltage uncertainties are all 5% while the time constant is $4 \pm 10\% = 4 \pm .4 \text{ seconds}$. Noting that it is only the static transfer function which is uncertain and not the pressure, we can write,

$$V(t) = V_i + (V_f - V_i)(1 - e^{-t/\tau})$$

$$V(t) = (45 \pm 5\% \text{ mV/kPa})[p_i + (p_f - p_i)(1 - e^{-t/\tau})]$$

$$V(2) = (45 \pm 5\%)[20 + (100 - 20)(1 - e^{2/(4 \pm .4)})]$$

Taking the time constant to be 4.4 s gives,

$$V_+(2) = (45 \pm 5\%)[20 + 80(1 - e^{-0.454})]$$

$$= (45 \pm 5\%)49.2 = 2.214 \pm 5\% = 2.214 \pm 0.111 \text{ volts}$$

so we expect the output to be 2.103 to 2.325 volts.

Taking the time constant to be 3.6 s gives,

$$V_-(2) = (45 \pm 5\%)[20 + 80(1 - e^{-0.555})]$$

$$= (45 \pm 5\%)54.1 = 2.435 \pm 5\% = 2.435 \pm 0.122 \text{ volts}$$

so we expect the output to be 2.313 to 2.557 volts. FINALLY the answer is that the output voltage for this measurement will be expected to lie in the range, 2.103 to 2.557 volts, which is 2.330 ± 0.227 or $2.330 \pm 9.7\%$.

SUPPLEMENTARY PROBLEMS

S1.1

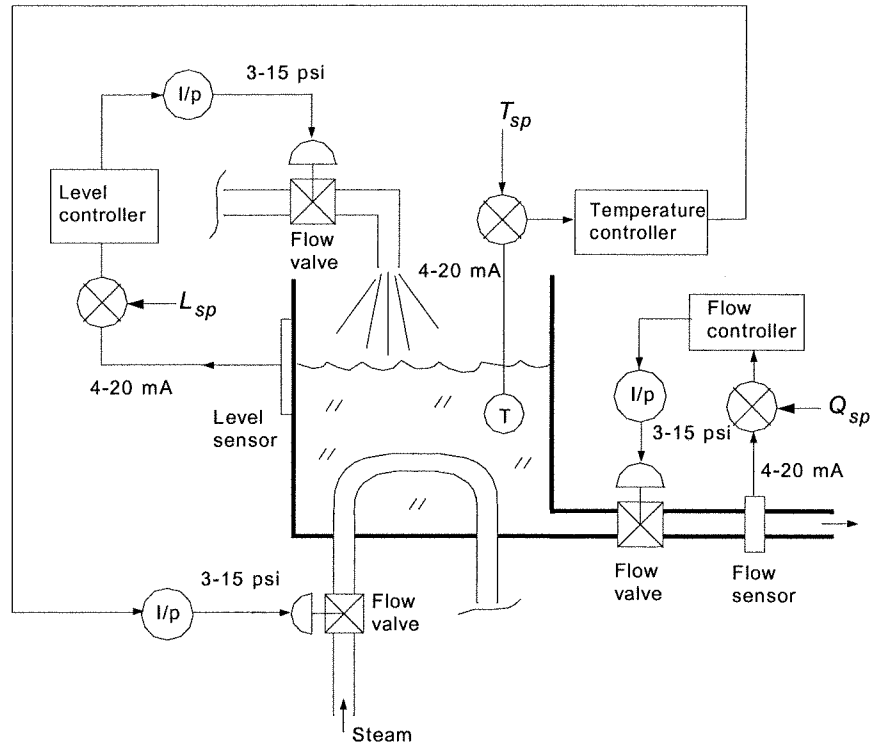

S1.2

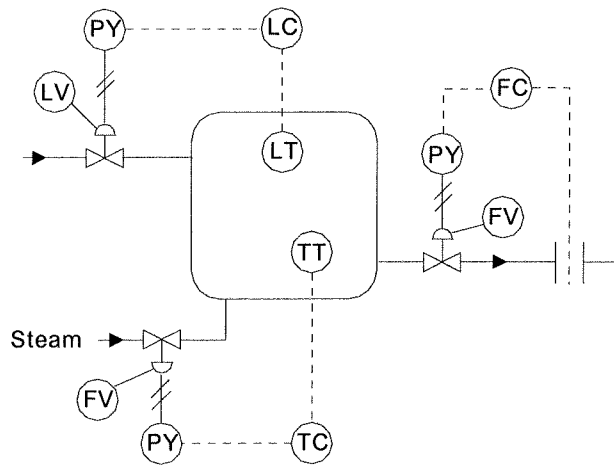

S1.3

Temperature is self-regulating because if the steam valve sticks at some setting the temperature will rise until equilibrium between heat flow out matches steam in, which will be some value less than the steam temperature. Flow out is self-regulating in the sense that for a stuck valve setting the flow simply maintains a fixed value. Level is not self-regulating because if the in-flow valve is stuck at some value which does not exactly match the out-flow the tank must empty or overflow.

S1.4

If the output flow valve was stuck closed then the level control system would simply shut off the input flow valve as the level rose and the level error became large. Therefore the tank would not overflow because of the level control system.

S1.5

Assume the tank is empty. Then sensor output is low and the relay is open so the output valve is closed. The level, h , will rise until the voltage to the amplifier reaches 6.0 volts. Then the relay closes which opens the valve and the level begins to drop (since outflow exceeds inflow). When the level drops to a point where the relay voltage becomes 4.8 V or less, the relay will open and the valve will close. This cycle then just repeats.

(a) To open the valve at 1.5 meters means the relay voltage must reach 6.0 V at that level,

$$6.0 = K(0.8h + 0.4) = K(0.8 \cdot 1.5 + 0.4) = 1.6K$$

$$\text{So, } K = 6/1.6 = 3.75$$

(b) The valve closes when the relay voltage drops to 4.8 V,

$$4.8 = 3.75(0.8h + 0.4)$$

$$h = (4.8/3.75 - 0.4)/0.8 = 1.1 \text{ meters}$$

(c) When the valve is closed the net input flow rate is,

$$Q_{in} = Q_1 + Q_2 = (5 + 2) \text{ m}^3/\text{min} = 7 \text{ m}^3/\text{min}$$

The volume of liquid in the tank is that of a cylinder of radius $r = 2$ m and height, h . The volume is given by the equation, $V = \pi r^2 h = 4\pi h$. The relationship between input flow rate, volume and time is given by,

$$V(t) = Q_{in}t.$$

Now we can calculate how long it takes from the height to rise from 1.1 to 1.5 meters,

$$t_{rise} = \Delta V(t)/Q_{in} = 4\pi(1.5 - 1.1) \text{ m}^3 / (7 \text{ m}^3/\text{min}) = 0.72 \text{ min}$$

When the valve opens there is an outflow of $9 \text{ m}^3/\text{min}$ and the inflow remains at $7 \text{ m}^3/\text{min}$, so the net is an outflow of $2 \text{ m}^3/\text{min}$. Therefore the time for level to drop from 1.5 m to 1.1 meters is given by,

$$t_{drop} = \Delta V(t)/Q_{out} = 4\pi(1.5 - 1.1) \text{ m}^3 / (2 \text{ m}^3/\text{min}) = 2.51 \text{ min}$$

So, the total period is 3.23 min.

S1.6

Since the pressure varies from 0 to 100 psi and the voltage is given by $0.5\sqrt{p}$ the voltage must vary from 0 to 5 volts. This voltage variation must produce a current that varies from 4 to 20 mA.

(a) The relationship between voltage and current will be given by, $I = mV + I_0$. From the given information we form:

$$4 \text{ mA} = m(0) + I_0$$

$$20 \text{ mA} = m(5) + I_0$$

From the first equation we find $I_0 = 4$ mA. The second equation gives, $m = (20 - 4) \text{ mA} / 5 \text{ V} = 3.2 \text{ mA/V}$

The transfer function equation is,

$$I = 3.2V + 4 \text{ mA}$$

(b) When the current is 20 mA the pressure is 100 psi. When the current is 19 mA the sensor output voltage is given by $V = (19 - 4)/3.2 = 4.6875 \text{ V}$. Therefore the pressure is found as

$$p = (V/0.5)^2 = (4.6875/0.5)^2 = 87.89 \text{ psi.}$$

So the pressure change is given by $\Delta p = 100 - 87.89 = 12.11 \text{ psi}$

(c) When the current is 4 mA the pressure must be 0 psi. The voltage at 5 mA is given by,

$$V = (5 - 4)/3.2 = 0.3125 \text{ V so the pressure is } p = (0.3125/0.5)^2 = 0.39 \text{ psi and therefore the}$$

pressure change is $\Delta p = 0.39 \text{ psi}$. The reason this is not the same as the previous case is because the output voltage of the sensor varies nonlinearly with the pressure. At low pressure the voltage (and also current) change very slowly with pressure while at high pressure the voltage (and current) change very fast with pressure.

(d) The following graph shows the nonlinear variation of the current versus pressure.

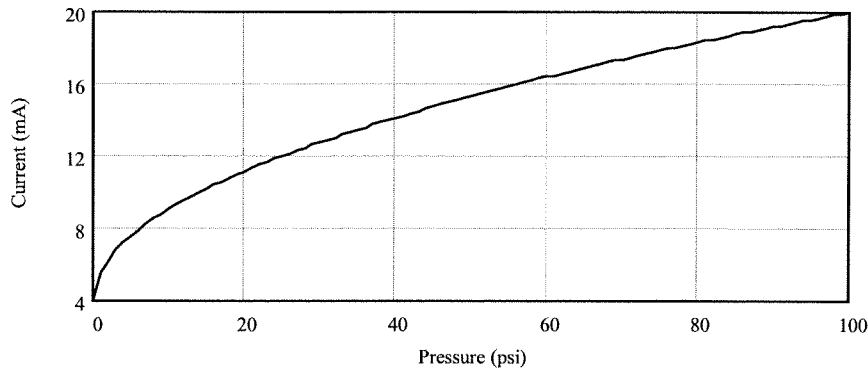

S1.7

(a) Since this is a first order time response sensor and the input is essentially an instantaneous change, the time response equation of Equation (1.7) will be very accurate. Therefore one need only measure the response at $t = 1$ second and calculate the "final value" using that equation. This must be done with voltage however and then pressure determined from the transfer function of the sensor.

(b) Given $V_p = 1.45$ volts at $t = 1$ second we first note that $V_i = 0.05(500)/2 = 1.12$ V. Then we have

$$V(t) = V_i + (V_f - V_i)[1 - e^{-t/\tau}]$$

$$1.45 = 1.12 + (V_f - 1.12)[1 - e^{-1/2}]$$

$$V_f = 1.12 + \frac{1.45 - 1.12}{1 - e^{-0.5}} = 1.959 \text{ V}$$

now use the transfer function to find the pressure, $p_{max} = (V_p/0.05)^2 - 500 = (1.959/0.05)^2 - 500 = 1035$ psi.

(c) For $p_{max} = 2500$ we first find the final voltage, $V_f = 0.05(2500+500).5 = 2.739$ V. Now we simply use Equation (1.7),

$$V(1) = 1.12 + (2.739 - 1.12)[1 - e^{-0.5}] = 1.76 \text{ V}$$

(d) First we find the final voltage from the measurement at one second,

$$V_f = 1.12 + \frac{V(1) - 1.12}{1 - e^{-0.5}}$$

and then the pressure from the transfer function of the sensor,

$$p_{max} = \left(\frac{V_f}{0.05} \right)^2 - 500$$

S1.8

(a) The elements of the system in Figure 1.35 have the following description:

- YIC 110 is a PLC which operates an open/closed valve in the B line. The valve is actuated by an electrical signal.
- FT 103 is an orifice plate flow sensor and transmitter with a pneumatic output that feeds a square root block having an electrical output.
- FC 104 is a flow controller which has a setpoint provided by FT 103, an electrical output signal to flow valve PY 104 and takes its input signal from flow sensor FT 104.
- PY 104 is an I/P converter which converts the electrical signal from the controller into a pneumatic signal for the flow valve.
- FT 104 is an orifice plate flow sensor with a pneumatic output connected to a square root detector which has an electrical signal output.
- PT 101 is a pressure sensor/transmitter with an electrical output.
- PC 101 is a controller for pressure which takes its setpoint input as a digital signal from a computer PC 101 and outputs an electrical signal to a control valve motor, M 101.
- M 101 is an electrical motor which actuates the valve for product C.
- PC 101 is a computer which provides the setpoint of the pressure control system.
- YIC 112 is a PLC which controls a vent valve

- TS 102 is a temperature sensor feeding an electrical signal to PLC YIC 102

(b) There are two control loops. Loop 101 is a pressure control valve. Pressure is measured by PT 101 and provided as input to controller PC 101. This unit then provides feedback by controlling the opening of the C valve via a motor, M 101. Loops 103 and 104 constitute cascaded control loops. The output of loop 103 is the setpoint of loop 104. Loop 104 controls flow of reactant A into the reaction chamber. The flow rate of B provides the setpoint of the A flow control loop. This system assures that both loops provide the same flow rate.

(c) PLC YIC 110 provides an overall system shut down by opening or closing the flow rate of reactant B into the reaction chamber. PLC YIC 112 opens a vent valve for the reaction chamber. PLC YIC 102 is an input of a temperature limit in the reaction chamber.

CHAPTER 2

2.1

We need to solve for the voltage dropped across the load, which is labeled V_y , in Figure 2.2. This can be found from Ohm's Law if the current is known by subtracting the voltage dropped across R_x from the source, V_x ,

$$V_y = V_x - IR_x$$

Let the current through the loop formed by V_x , R_x and R_L in Figure 2.2 be described by I and assume a clockwise direction. This current is found from Ohm's Law as the voltage divided by the total resistance,

$$I = \frac{V_x}{R_x + R_y}$$

Substituting in the equation for V_y given above, provides the required result,

$$V_y = V_x \left(1 - \frac{R_x}{R_x + R_y} \right)$$

2.2

We can find the circuit output voltage amplitude by using the impedance. Thus the output is simply a divider loaded voltage:

$$V_{out} = \frac{V_S Z_L}{Z_L + Z_S} \quad \text{where } V_S = 5\angle 0^\circ, Z_L = -j/\omega C = j/(2\pi fC)$$

so, $Z_L = [2\pi(200 \text{ Hz})(0.22 \mu\text{F})]^{-1} = -3617j \Omega$ and $Z_S = 2000 + 600j$. Thus the output voltage is,

$$V_{out} = \frac{(5\angle 0^\circ)(0 - 3617j)}{(2000 + 600j - 3617j)} = 4.2 - 2.8j$$

so the amplitude is $|V_{out}| = 5.04 \text{ V}$

2.3

The divider output voltage is found from;

$$V_D = \frac{V_S R_2}{R_1 + R_2} = \frac{(10)(500)}{R_1 + 500}$$

(a) For $R_1 = 520 \Omega$, $V_D = 4.90 \text{ V}$ and for $R_1 = 2500 \Omega$, $V_D = 1.67 \text{ V}$.

(b) Sensor dissipation is given by $P_S = V_S^2/R_S$, where $V_S = 10 - V_D$ therefore, for $R_1 = 520 \Omega$, $P_S = 50.0 \text{ mW}$ and for $R_1 = 2500 \Omega$, $P_S = 27.8 \text{ mW}$

2.4

The solution to Example 2.2 can be expressed using Equation (2.2) as,

$$V_D = \frac{5R_2}{10000 + R_2}$$

A plot of this function for R_2 varying between $4 \text{ k}\Omega$ and $12 \text{ k}\Omega$ shows the result:

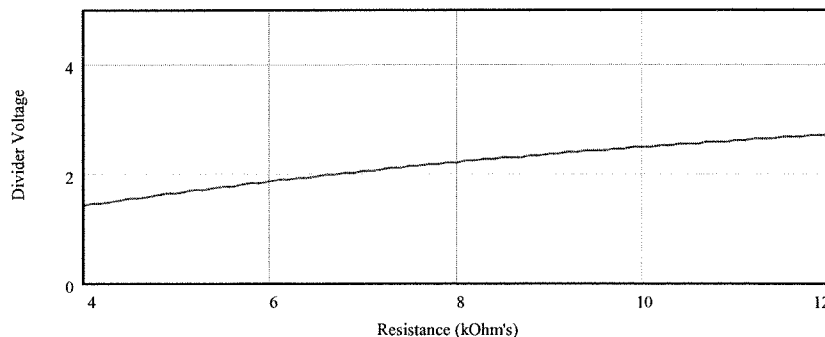

Clearly this is nonlinear and the voltage increases with increasing resistance.

For Problem 2.3 a plot of the divider voltage give above is,

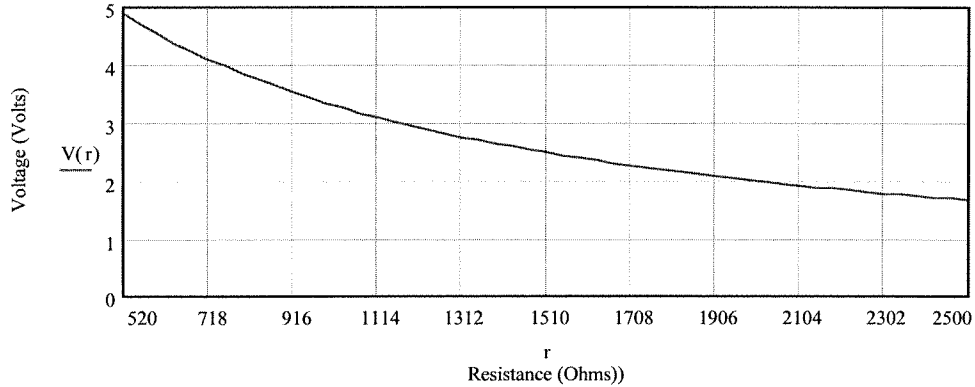

In this case the plot is again nonlinear but the voltage decreases with increasing resistance.

2.5

We put the right side of Equation (2.6) over a common denominator by multiplying both terms by the ratio of the resistance sums,

$$\Delta V = \frac{VR_3}{R_1 + R_3} \frac{R_2 + R_4}{R_2 + R_4} - \frac{VR_4}{R_2 + R_4} \frac{R_1 + R_3}{R_1 + R_3} = \frac{V[R_3(R_2 + R_4) - R_4(R_1 + R_3)]}{(R_1 + R_3)(R_2 + R_4)}$$

Now the expression in the brackets of the numerator is multiplied out and the product R_3R_4 cancels out, leaving the desired result,

$$\Delta V = V \frac{R_3R_2 - R_1R_4}{(R_1 + R_3)(R_2 + R_4)}$$

2.6

The Thevenin resistance between a and b in the bridge of Figure 2.5 is found by replacing the source by its internal resistance, which is assumed to be zero. Then the circuit can be redrawn as,

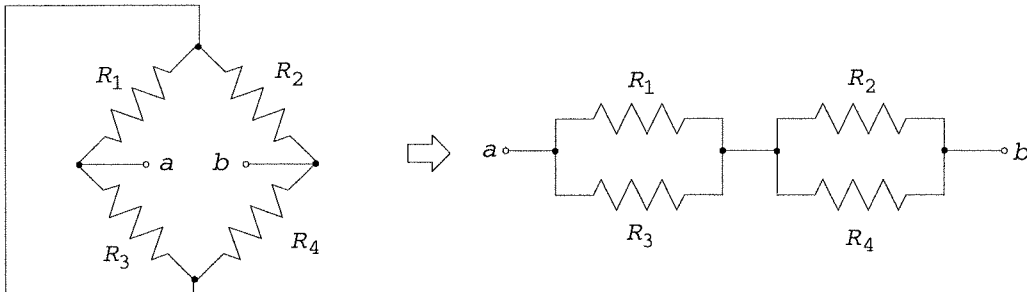

In this case you can see that we have the parallel combination of R_1 and R_3 in series with the parallel combination of R_2 and R_4 . Thus by the parallel rule for two resistors we have,

$$R_{Th} = \frac{R_1R_3}{R_1 + R_3} + \frac{R_2R_4}{R_2 + R_4}$$

2.7

From the null condition of Equation (2.8) we solve for $R_4 = R_3R_2/R_1$, so

$$R_4 = (448 \Omega)(1414 \Omega)/(227 \Omega) = 2791 \Omega$$

2.8

(a) The value of R_3 to null the bridge is found by solving Equation (2.8) for this resistor,

$$R_3 = R_1R_4/R_2 = (100 \Omega)(50 \Omega)/(100 \Omega) = 50 \Omega$$

(b) The detector resolution needed to resolve a resistance change of 0.1Ω is found from Equation (2.6) or (2.7) when R_4 has changed to 50.1Ω (or 49.9Ω),

$$\Delta V = \frac{(10V)(50\Omega)}{(50\Omega + 100\Omega)} - \frac{(10V)(50.1\Omega)}{(50.1\Omega + 100\Omega)} = -4.44\text{mV}$$

If 49.9Ω were used the result would be $\Delta V = +4.45 \text{ mV}$, where the difference is due to the nonlinearity.

2.9

A diagram will help you understand this problem. The circuit is,

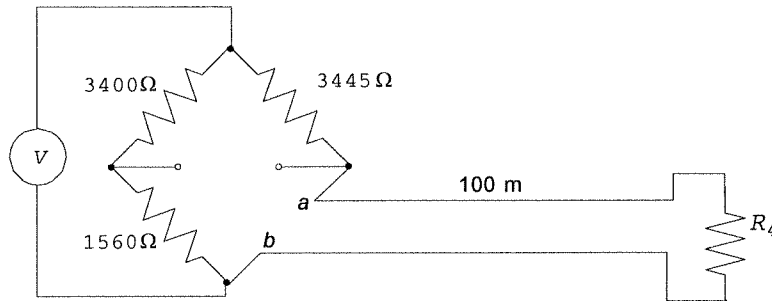

If you use the null equation to find R_4 , it will give the resistance from a to b in the schematic, which includes the two 100 m lead resistances. Thus these must be subtracted to find the actual sensor resistance.

$$R_{ab} = (3445 \Omega)(1560 \Omega)/(3400 \Omega) = 1580.6 \Omega$$

but the lead resistance is,

$$R_{lead} = 2(100 \text{ m})(0.3048 \text{ m/ft})(0.45 \Omega/\text{ft}) = 295.3 \Omega$$

So the actual sensor resistance is,

$$R_4 = 1580.6 \Omega - 295.3 \Omega = 1285.3 \Omega$$

2.10

(a) The bridge null equation is the same for voltage or current detection. Thus, from Equation (2.8) we find, $R_2 = R_1 R_4 / R_3 = (250 \Omega)(340 \Omega) / (500 \Omega) = 170 \Omega$

(b) If $R_2 = 190 \Omega$ the bridge is not nulled (because null occurs for 170Ω). To find the resulting offnull current we use Equation (2.11) along with Equations (2.9) and (2.10),

$$R_{Th} = \frac{(250)(500)}{250 + 500} + \frac{(190)(340)}{190 + 340} = 288.6 \Omega$$

$$V_{Th} = (1.5) \left[\frac{500}{500 + 250} - \frac{340}{340 + 190} \right] = 0.0378 \text{ V}$$

Thus the current is $I_G = \frac{0.0378}{288.6 + 150} = 86.2 \mu\text{A}$

2.11

(a) The value of R_3 to null the bridge with no current is just the null equation for the current balance bridge, Equation (2.8) except that R_4 is now $R_4 + R_5$. Thus,

$$R_3 = R_1(R_4 + R_5)/R_2 = (1 \text{ k}\Omega)(590 \Omega + 10 \Omega)/(1 \text{ k}\Omega) = 600 \Omega$$

(b) If the current is 0.25 mA we must use Equation (2.15) at null to find the value of R_3 .

$$0 = 10 \left[\frac{R_3}{1000 + R_3} - \frac{590 + 10}{1000 + 590 + 10} \right] - (0.00025)(10)$$

Solving this equation for R_3 gives, $R_3 = 600.6 \Omega$

2.12

The value of potential can be found from Equation (2.17),

$$V_x + \frac{10(10 \text{ k}\Omega)}{(10 \text{ k}\Omega + 10 \text{ k}\Omega)} - \frac{10(9.73 \text{ k}\Omega)}{10 \text{ k}\Omega + 9.73 \text{ k}\Omega} = 0 \quad \text{or,} \quad V_x + 5.00 - 4.93 = 0$$

So, $V_x = -68.4 \text{ mV}$ and the negative means that the unknown voltage subtracts from the five volts at point a so that the unknown source positive is connected to a with respect to c in Figure (2.9).

2.13

For the ac bridge we have a null condition of $Z_1 Z_4 = Z_2 Z_3$. For the capacitor the impedance is given by $Z = 1/j\omega C$, but since the j and ω appear in all terms they cancel leaving the null condition given by, $C_1 C_4 = C_2 C_3$. Therefore we can solve for C4 easily,

$$C_4 = C_2 C_3 / C_1 = (0.31)(0.27)/(0.4) \mu\text{F} = 0.21 \mu\text{F}$$

2.14

(a) The impedences for null are $Z_1 = 1000$

$$Z_2 = 2000$$

$$Z_3 = 100 + 0.25\omega j$$

$$Z_4 = R_4 + L_4\omega j$$

The null equaiton becomes, $1000(R_4 + j\omega L_4) = 2000(100 + 0.25\omega j)$

Equating real and imaginary parts,

$$1000R_4 = 200000 \quad \text{or} \quad R_4 = 200 \Omega \quad 1000\omega L_4 = 500\omega \quad \text{or} \quad L_4 = 0.5 \text{ H}$$

(b) If L4 changes to 0.51 H there will be an offnull voltage given by Equation (2.20).

For a frequency of 1 kHz the impedences are:

$$Z_1 = 1000$$

$$Z_2 = 2000$$

$$Z_3 = 100 + 0.25(2)(\pi)(1000)j = 100 + 1571j$$

$$Z_4 = 200 + 0.51(2)(\pi)(1000)j = 200 + 3204j$$

Thus the offnull voltage is given by,

$$\Delta E = 5 \left[\frac{2000(100 + 1571j) - (1000)(200 + 3204j)}{(1100 + 1571j)(2200 + 3204j)} \right] = 5 \frac{62j}{-2614 + 6980j}$$

which can be reduced to $\Delta E = 38.9 - 14.6j$ where the real part is the in-phase part and the -14.6 is the quadrature part.

2.15

A low pass to attenuate 0.5 Mhz by 97% means that there is only 3% left. Thus we find the critical frequency which gives ratio of output to input voltage of 0.03 when the frequency is 0.5 mHz.

Equation (2.23) provides the required relationship,

$$0.03 = \frac{1}{\left[1 + \left(\frac{f}{f_c} \right)^2 \right]^{1/2}} = \frac{1}{\left[1 + \left(\frac{5 \times 10^5}{f_c} \right)^2 \right]^{1/2}}$$

The solution is $f_c = 15 \text{ kHz}$. To find the values of resistor and capacitor we note that the critical frequency is given by, $f_c = 1/(2\pi RC)$. Thus $RC = 1.06 \times 10^{-5}$. Any combination of R and C that give this product will work but we must pick practical values. Let's try $C = 0.01 \mu\text{F}$, then we will need $R = 1.06 \text{ k}\Omega$, which seems reasonable. The attenuation of a 400 Hz signal will be found from the above equation with $f = 400 \text{ Hz}$ and $f_c = 15 \text{ kHz}$,

$$\left| \frac{V_{out}}{V_{in}} \right| = \frac{1}{\left[1 + \left(\frac{400}{15000} \right)^2 \right]^{1/2}} = 0.9996$$

so the output is only down by 0.04%.

2.16

The attenuation is simply found from Equation (2.23)

$$\left| \frac{V_{out}}{V_{in}} \right| = \frac{1}{\left[1 + \left(\frac{1000}{3500} \right)^2 \right]^{1/2}} = 0.96$$

so the attenuation is $1 - 0.96 = 0.04$

2.17

We find the critical frequency for which a 120 Hz signal has an output to input voltage ratio of 0.01,

$$\left| \frac{V_{out}}{V_{in}} \right| = \frac{(f / f_c)}{\left[1 + (f / f_c)^2 \right]^{1/2}} \quad \text{so} \quad 0.01 = \frac{(120 / f_c)}{\left[1 + (120 / f_c)^2 \right]^{1/2}}$$

From this equation we find $f_c = 12$ kHz. If we pick $C = 0.01 \mu\text{F}$ then $R = 1.33$ k Ω . The attenuation of a 30 kHz signal is,

$$\left| \frac{V_{out}}{V_{in}} \right| = \frac{(30 / 12)}{\left[1 + (30 / 12)^2 \right]^{1/2}} = 0.93 \quad \text{so the attenuation is } 0.07 \text{ or } 7\%.$$

2.18

In this case we solve for f_c . Down 20 dB means that $-20 = 20\log_{10}(V_{out}/V_{in})$ so that $(V_{out}/V_{in}) = 10^{-1} = 0.1$

$$\left| \frac{V_{out}}{V_{in}} \right| = 0.1 = \frac{(1000 / f_c)}{\left[1 + (1000 / f_c)^2 \right]^{1/2}} \quad \text{Solving this for the critical frequency gives the}$$

answer, $f_c = 9.95$ kHz

2.19

The schematic for this filter is a low pass followed by a high pass,

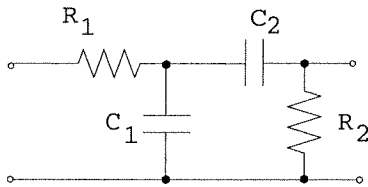

The critical frequency of the low pass will be 10 kHz and the critical frequency of the high pass which follows will be 100 Hz. This way a signal between 100 Hz and 10 kHz will be passed by the system. The values of components will thus be given by,

$$f_{c1} = 10,000 = 1 / (2\pi R_1 C_1) \quad \text{and} \quad f_{c2} = 100 = 1 / (2\pi R_2 C_2).$$

which can be written, $R_1 C_1 = 1.59 \times 10^{-5}$ and $R_2 C_2 = 1.59 \times 10^{-3}$.

Using a resistance ratio of 0.05 means that we have another equation, $R_2 / R_1 = 0.05$. Let's try $C_2 = 1 \mu\text{F}$, then $R_2 = 1591 \Omega$. From the resistance ratio we find $R_1 = 31.83$ k Ω and this gives $C_1 = 500$ pF. These are all reasonable component values.

A plot of this function shows the overall filter response:

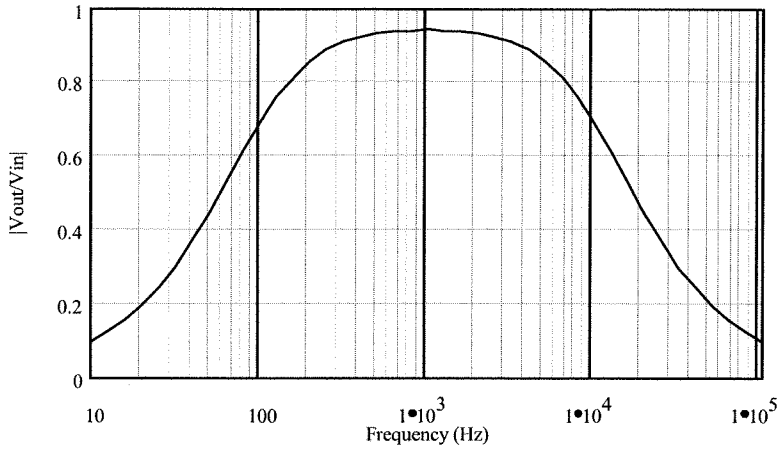

2.20

This is not an easy problem. The solution must account for the signal reduction at 200 Hz from the filter AND the reduction due to loading by the 10 kΩ input resistance of the amplifier. The circuit model, including the 10 kΩ input impedance amplifier is,

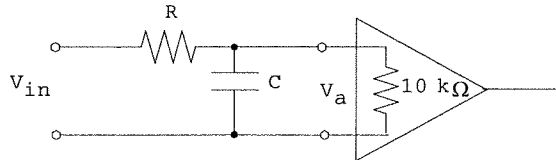

The problem specifies that, $|V_a/V_{in}| < 0.99$ at 200 Hz, i.e., no more than a 1% reduction. Using the Thevenin equivalent circuit of the filter we can model the system as,

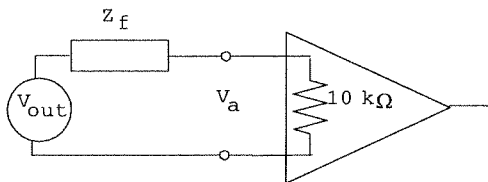

Where V_{out} is given by the filter equation and V_a is given by the loading,

$$\frac{V_{out}}{V_{in}} = \frac{1}{\sqrt{1 + (f/f_c)^2}} \quad \text{and} \quad \left| \frac{V_a}{V_{out}} \right| = \frac{10k + 0j}{|10k + Z_f|}$$

Since the product of the two transfer functions must be 0.99 at 200 Hz, let's make the filter transfer function 0.995 so that the loading must be 0.995, since $(0.995)(0.995) \approx 0.99$.

Let's first find the critical frequency for which $|V_{out}/V_{in}| = 0.995$ at 200 Hz,
 $0.995 = [1 + (200/f_c)^2]^{-1/2}$ or, squaring, $0.99^{-1} = 1 + (200/f_c)^2$

which gives, $(200/f_c) = 0.1004$ so that $f_c = 1992$ Hz where $f_c = 1/(2\pi RC)$

Now Z_f is the impedance of R and C in parallel assuming zero source impedance. Thus,

$$Z_f = \frac{R/j\omega C}{R + 1/j\omega C} = \frac{R}{1 + j\omega RC} = \frac{R}{1 + (\omega RC)^2} (1 - j\omega RC) \quad \text{But } RC = (1/2\pi f_c) \text{ so } Z_f \text{ can be}$$

written in the form,

$$Z_f = \frac{R}{1 + (f/f_c)^2} [1 - j(f/f_c)] = \frac{R}{1 + (200/1992)^2} (1 - 200j/1992)$$

or,

$$Z_f = 0.99R(1 - .1004j)$$

Now the loading condition can be written,

$$\frac{V_a}{V_{out}} = 0.995 = \frac{10000}{|10000 + .99R(1 - .1004j)|}$$

This can be solved for $R = 50.1 \Omega$ so that $C = 1/(2\pi Rf_c) = 1.6 \mu\text{F}$.

The attenuation of the 4 to 5 kHz noise is found from the same filter and loading equations with $f = 4 \text{ kHz}$ and 5 kHz .

The above equations show that at 4 kHz , $V_a/V_{in} = 0.45$ and at 5 kHz , $V_a/V_{in} = 0.37$. So the noise is reduced by about 30 to 50%.

2.21

We find the critical frequencies from the requirements of signal reduction at 500 Hz and 500 kHz . First let's reduce the voice (500 Hz) by 80%, which means the voltage ratio will be 0.2. This is the high pass filter so we have,

$$0.2 = \frac{(500/f_H)}{\sqrt{1+(500/f_H)^2}} \text{ which gives } f_H = 2.45 \text{ kHz}$$

Now for reduction of the 500 kHz signal by 90% we are using the low pass section of the filter,

$$0.1 = \frac{1}{\sqrt{1+(500000/f_L)^2}} \text{ which gives } f_L = 50 \text{ kHz}$$

From the critical frequency equations we find, $R_L C_L = 6.49 \times 10^{-9}$ and $R_H C_H = 3.18 \times 10^{-6}$. Let's try $C_L = 0.05 \mu\text{F}$, then $R_L = 1300 \Omega$. Since the ratio is specified as 0.02, $R_H = 1300 \Omega / 0.02 = 65 \text{ k}\Omega$. This leaves only C_L , which is found to be $C_H = 3.18 \times 10^{-6} / 65 \times 10^3 \approx 50 \text{ pF}$.

To find the effect on the bandpass frequency let us evaluate the response at the half band frequency of 5.5 kHz using Equation 2.25. The actual critical frequencies are $f_L = 2448 \text{ Hz}$ and $f_H = 48970 \text{ Hz}$. Thus we have,

$$\left| \frac{V_{out}}{V_{in}} \right| = \frac{(48970)(5500)}{\sqrt{(5500^2 - (48970)(2448))^2 + 5500^2 (2448 + 1.02(48970))^2}} = 0.89$$

so there is about an 11% reduction of the pass band.

2.22

Equations 2.27 for the twin-T filter allow determination of component values. In this case we want to reject 4.5 kHz , so we have $4.5 \text{ kHz} = 0.785f_c$, which gives $f_c = 5.73 \text{ kHz}$. Thus we find the values of the resistor and capacitor as, $RC = 1/(2\pi f_c) = 2.78 \times 10^{-5}$. Let's try $C = 0.01 \mu\text{F}$, then $R = 2.78 \text{ k}\Omega$. The grounding resistor and capacitor are then determined from $R_1 = \pi R / 10 = 873 \Omega$ and $C_1 = 10C / \pi = 0.03 \mu\text{F}$.

Effect on the signal frequencies can be estimated from the graph of Figure 2.24. For the lower signal frequency we form a ratio of $f/f_c = 1/5.73 = 0.175$. From the graph this gives an output ratio of about 0.7 so about 30% of the signal is lost. At 10 kHz the ratio is 1.7 and you can see that the output is about 0.3 so about 70% of the signal is lost. The upper end of 50 kHz has a ratio of 8.73 and the graph shows that the output is at about 0.9 so only 10% is lost.

2.23

In the case of the inverting amplifier we need two so that the overall gain will be +100. Thus the following circuit will satisfy this need. The first has a gain of -100 and an input impedance of $1.5 \text{ k}\Omega$ and the second a gain of -1.

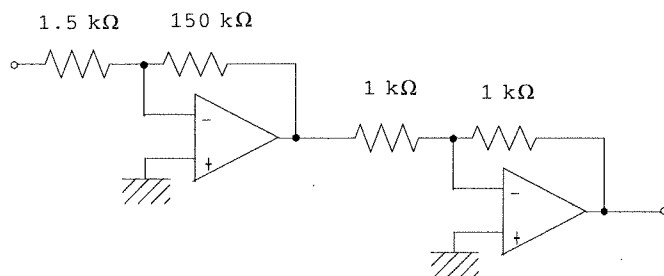

A noninverting amplifier can be constructed with only one op amp, as:

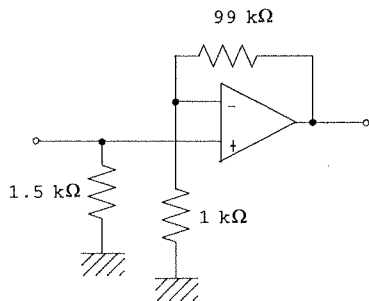

2.24

A differential amplifier with a gain of 22 can be constructed as follows:

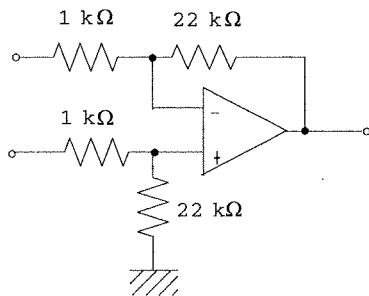

2.25

If the input to an integrator is $V_{in} = \text{constant}$, then the output is,

$$V_{out} = -(1/RC)(V_{in})t = -0.1V_{in}t \quad \text{since } RC \text{ is given to be } 10.$$

We need this to be $0.5t$ so it is clear that $V_{in} = -5$ Volts. The following circuit will provide this. We have assumed that the -5 volts must be supplied from the -15 V supply and have taken into account loading.

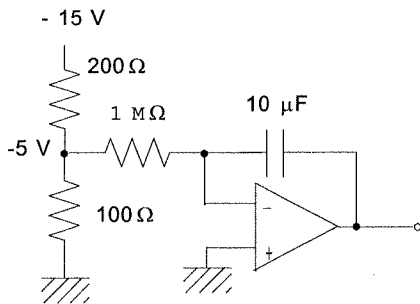

2.26

The first figure shows the circuit with a summing amplifier and the second with a differential amplifier. A voltage follower may be necessary in both to prevent loading the source.

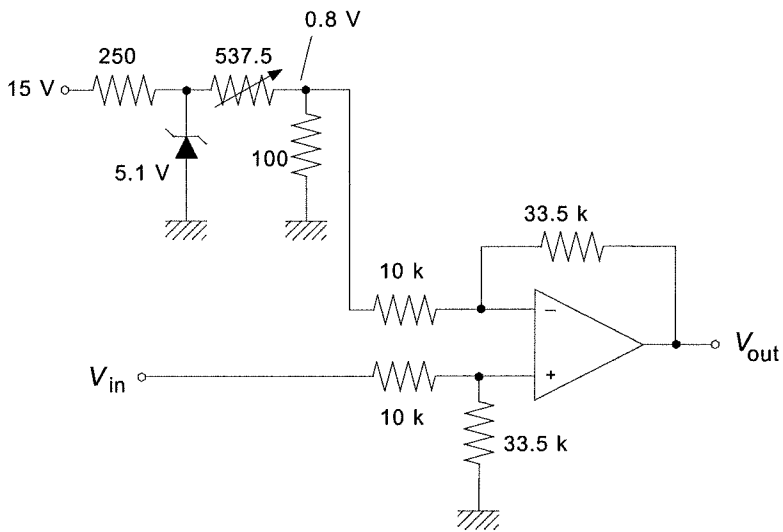
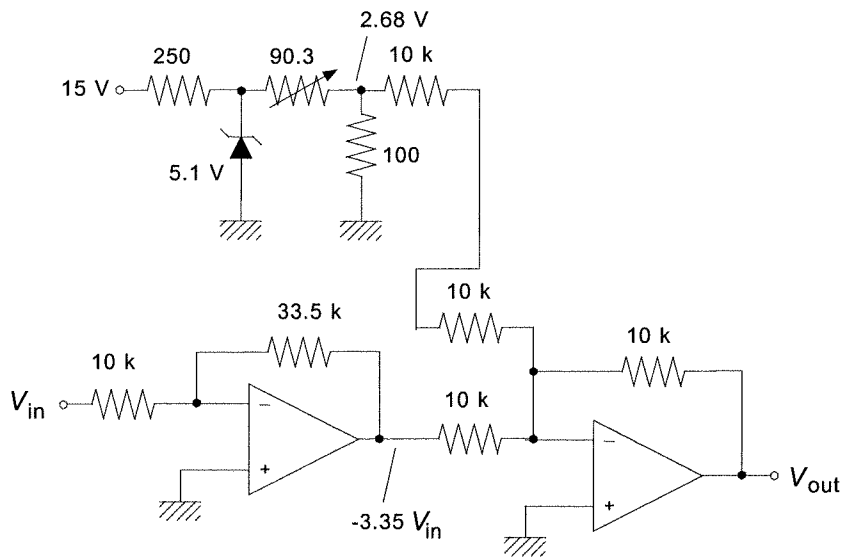

2.27

The amplifier gain is given by $A = R_2/R_1 = 470/2.7 = 174$

The common mode gain is given by $A_{cm} = 0.087/2.5 = 0.0348$

Thus, $CMRR = A/A_{cm} = 174/0.0348 = 5000$

and then, $CMR = 20\log_{10}(CMRR) = 20\log_{10}(5000) = 74 \text{ dB}$

2.28

The circuit model for the derivation is:

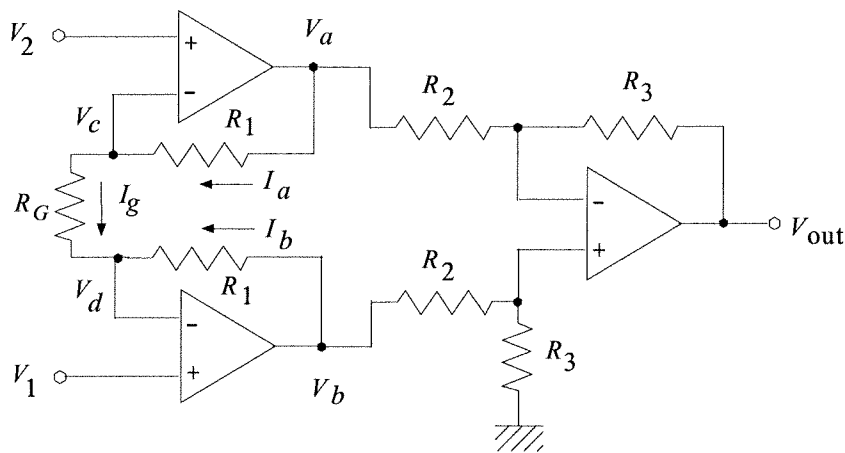

Assumptions are: (1) no current into op amp inputs, (2) no voltage across op amp inputs, (3) no loading of differential amplifier by first stages, (4) zero source resistances.

A. From (2) we conclude $V_c = V_2$ and $V_d = V_1$

B. From (3) we conclude $V_{out} = (R_3/R_2)(V_b - V_a)$ (standard differential amplifier)

C. From (1) we conclude, $I_g - I_a = 0$ and $I_g + I_b = 0$

D. From Ohm's Law we can write these currents in terms of voltages and resistances, also using A.

$$\frac{V_2 - V_1}{R_g} - \frac{V_a - V_2}{R_1} = 0 \qquad \frac{V_2 - V_1}{R_g} + \frac{V_b - V_1}{R_1} = 0$$

We solve the first for V_a and the second for V_b ,

$$V_a = V_2 + (R_1/R_g)(V_2 - V_1) \text{ and } V_b = V_1 - (R_1/R_g)(V_2 - V_1)$$

This result is combined with B. and some algebra to find the expression;

$$V_{out} = \left(1 + \frac{2R_1}{R_g}\right) \frac{R_3}{R_2} (V_1 - V_2)$$

2.29

This design is accomplished by switching in different values of R_g to provide the desired gains. The net gain is given by the express just above. Suppose we make $R_3/R_2 = 1$ then the gain variation is given by the expression,

$$G = (1 + 2R_1/R_g)$$

Solving this for R_g ,

$$R_g = 2R_1/(G-1)$$

Let's pick $R_1 = 100 \text{ k}\Omega$

$G = 1$ $R_g = \infty$ (open circuit)

$G = 10$ $R_g = 22.2 \text{ k}\Omega$

$G = 100$ $R_g = 2.02 \text{ k}\Omega$

$G = 1000$ $R_g = 200 \text{ }\Omega$

We pick $R_3 = R_2 = 10 \text{ k}\Omega$. The following circuit results:

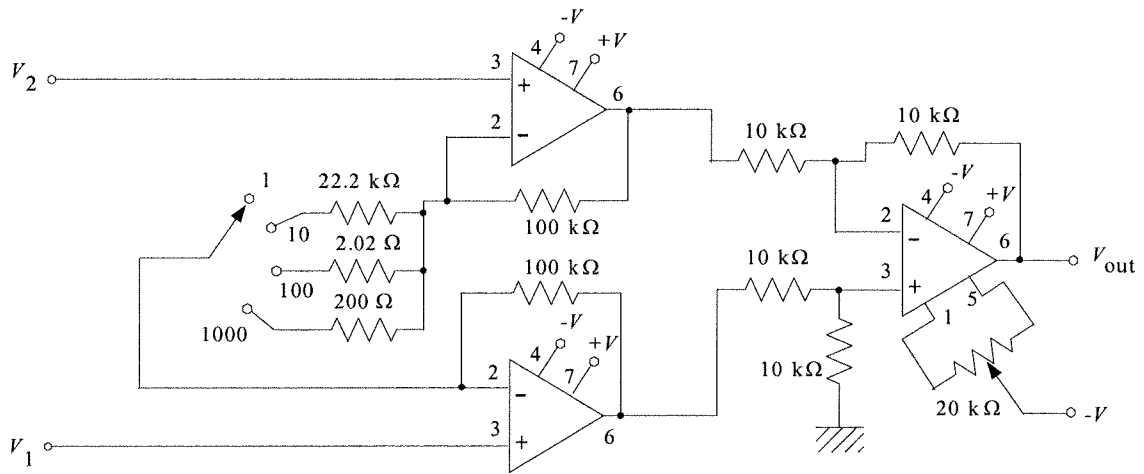

2.30

This can be provided by a summing amplifier with a gain of 1/3 on all inputs, followed by a unity gain inverter to get the polarity right.

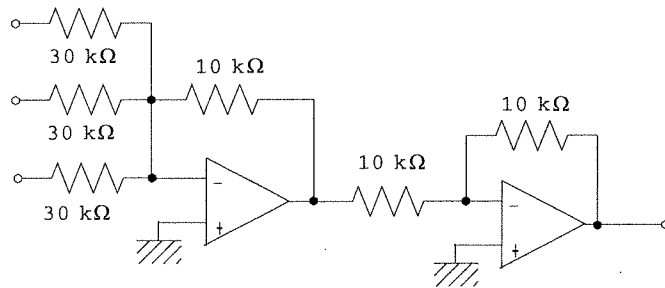

2.31

This equation consists of a sum of an gain term and an integration term. Thus we form the circuit from these same elements as shown below. The gains are adjusted to provide the gain of 10 and an integral gain of 4.

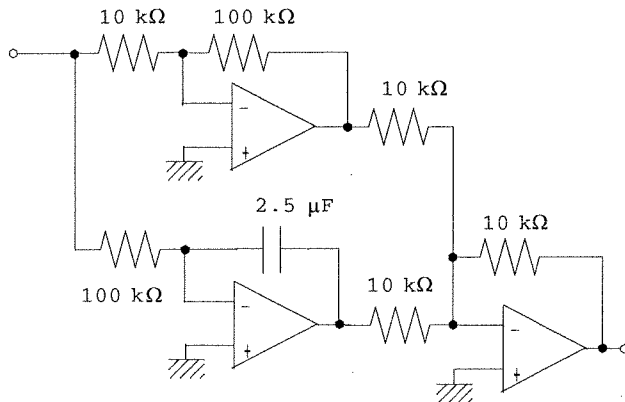

2.32

For the V-to-I converter we have, from Equations (2-35) and (2-36),

$$I = -(R_2/R_1R_3)V_{in} \text{ provided, } R_1(R_3 + R_5) = R_2R_4$$

Thus it is clear that one equation that can be formed is,

$R_2/(R_1R_3) = 2.1 \times 10^{-3}$ and that $V_{in} = - |V_{in}|$ which means that an inverter will be needed at the front end.

This means there are two equations and five unknowns. So, we can select three, using good judgement of course. Let's try $R_1 = R_3 = 1 \text{ k}\Omega$. Then we find R_2 as,

$$R_2 = (10^3)(10^3)(2.1 \times 10^{-3}) = 2.1 \text{ k}\Omega$$

We can still pick one resistor, let's take $R_5 = 500 \Omega$ then R_4 is found to be,

$$(1 \text{ k}\Omega)(1 \text{ k}\Omega + 0.5 \text{ k}\Omega) = (2.1 \text{ k}\Omega)R_4$$

$$R_4 = 1.5 \text{ k}\Omega/2.1 = 714 \Omega$$

These satisfy the requirements. The circuit is as in Figure 2.33 but an inverter is needed to give $-|V_{in}|$ as the input. The maximum load is found from Equation (2-40).

$$R_{ML} = \frac{(R_4 + R_5)(V_{sat}/I_M - R_3)}{(R_3 + R_4 + R_5)}$$

$$R_{ML} = \frac{(714 + 500)(12/0.005 - 1000)}{(1000 + 714 + 500)}$$

$$R_{ML} = 768 \Omega$$

Of course many other solutions are possible.

2.33

Let us first establish the range of bridge off-null voltage for the given range of R_4 variation. It is clear that the bridge will be nulled at $R_4 = 120 \Omega$ so that $\Delta V = 0$. When the resistance is 140Ω the off-null voltage will be,

$$\Delta V = 10 \left[\frac{120}{(120 + 120)} - \frac{140}{(120 + 140)} \right]$$

$$\Delta V = -0.385 \text{ volts}$$

The required signal conditioning must satisfy the following relation:

$$V_{out} = k\Delta V + V_0$$

where when $\Delta V = 0$ ($R_4 = 120 \Omega$) $V_{out} = 0 \text{ V}$ and when $\Delta V = -0.385 \text{ volts}$ ($R_4 = 140 \Omega$), $V_{out} = 5.0 \text{ volts}$.

This gives two equations for the two unknowns, k and V_0 ,

$$0 = k(0) + V_0 \text{ therefore, } V_0 = 0$$

$$5.0 = -.385k$$

$$k = -12.987 \sim -13$$

so,

$$V_{out} = 13\Delta V$$

This is provided by the following differential amplifier circuit. The polarity is taken into account by how the bridge is connected. The following plot of V_{out} versus R_4 shows that the relation is not exactly linear but quite close. The nonlinearity is a result of the bridge.

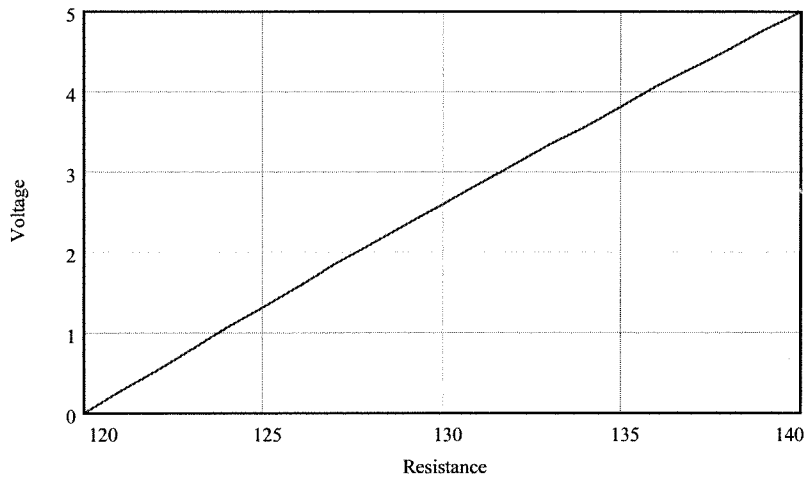
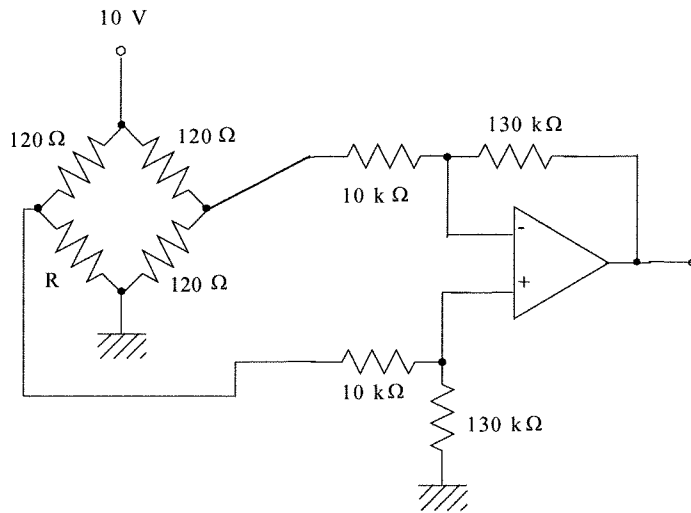

2.34

Example 2.2 involves a sensor used in a divider. The example shows that as the transducer resistance varies from 4 kΩ to 12 kΩ, the divider voltage varies from 1.43 to 2.73 volts. A signal conditioning circuit is needed which satisfies,

$$V_{out} = kV_{in} + V_0$$

where k and V_0 are determined to satisfy the conditions:

$$V_{out} = 0 \text{ V when } V_{in} = 1.43 \text{ V (4 k}\Omega\text{)}$$

$$V_{out} = 5 \text{ V when } V_{in} = 2.73 \text{ V (12 k}\Omega\text{)}$$

Thus,

$$0 = 1.43k + V_0$$

$$5 = 2.73k + V_0$$

subtracting allows k to be found as, $k = 5/(2.73-1.43) = 3.85$

and then $V_0 = -1.43k = -1.43(3.85) = -5.51 \text{ V}$. Thus the relation is,

$$V_{out} = 3.85V_{in} - 5.51$$

or,

$$V_{out} = 3.85(V_{in} - 1.43)$$

Now, to develop an appropriate circuit we must note that the effective output resistance of the divider source is, at the mid-range, about 4 kΩ. To avoid loading problems the signal conditioning circuit must have a much larger input resistance. There are many circuits. The following one isolates the divider with a voltage follower and uses the second relation above with a differential amplifier. the 1.43 volts is provided by another divider.

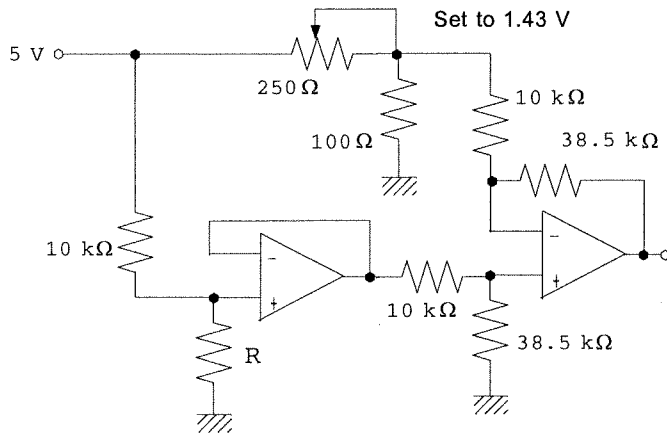

2.35

The input conditions, from Problem 2.3, and the requirements of this problem can be summarized as follows:

R	$V_D = V_{in}$	V_{out}
520Ω	4.90 V	0 V
2500Ω	1.67 V	5 V

The equation relating V_{in} and V_{out} is,

$$V_{out} = kV_{in} + V_0$$

Thus we have the equations,

$$0 = 4.90k + V_0$$

$$5 = 1.67k + V_0$$

subtracting, $k = 5/(1.67-4.9) = -1.55$ and so $V_0 = 4.9(1.55)$. The final relation is,

$$V_{out} = -1.55V_{in} + 7.585$$

The following op amp circuit provides this result.

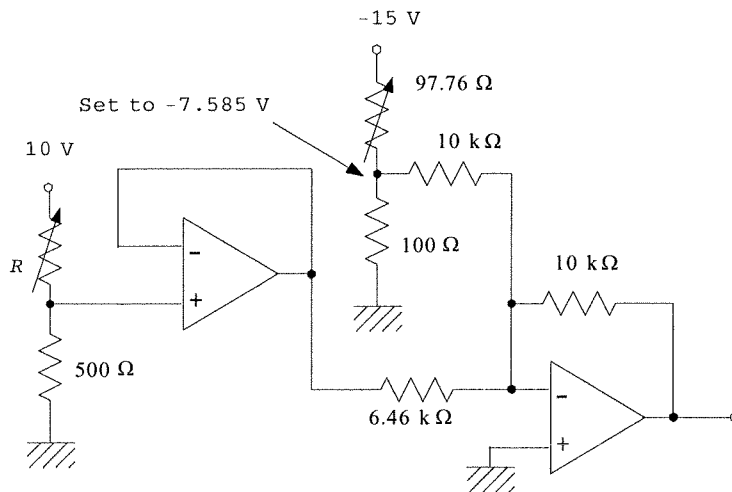

2.36

Let us first develop an equation for the output voltage varying linearly with R ,

$$V_{out} = KR + V_0$$

Using the given facts we form,

$$0 = K(1 \text{ k}\Omega) + V_0$$

$$5 = K(5 \text{ k}\Omega) + V_0$$

Subtracting, $K = 5/4 = 1.25 \text{ V/k}\Omega$ and $V_0 = -1.25 \text{ V}$. So the relation is $V_{out} = 1.25R - 1.25$

An inverting amplifier has a transfer function of, $V_{out} = -(R_2/R_1)V_{in}$. If we let $R_2 = R$ and $V_{in}/R_1 = 1.25$ then we will have the first part of the required equation. We let $V_{in} = 1.25$ V and $R_1 = 1$ k Ω . The rest is just a summing amplifier, which will also invert the sign. The circuit is as follows:

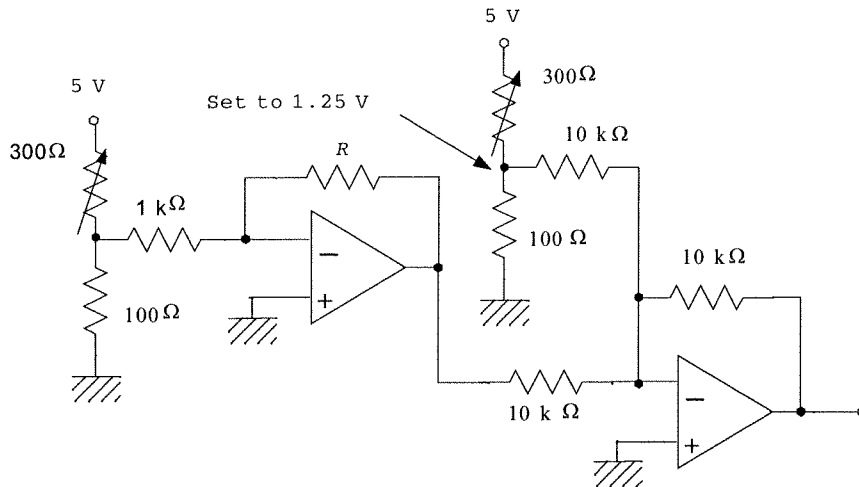

2.37

The current can be converted to a voltage by a current to voltage op amp circuit. This gives $V = -IR$, so if we make $R = 100 \Omega$ then the voltage will be $V = -100I$. For a current range of 4 to 20 mA this will mean a voltage of -0.4 to -2.0 volts. The setpoint will be 0.95 volts. A summing amplifier can be used to construct the error voltage, provide the needed scale factor and invert the sign. An error of 1 mA will provide an error voltage of 0.1 volts, so we need a gain of 5 to obtain the desired scale factor of 0.1 V/mA.

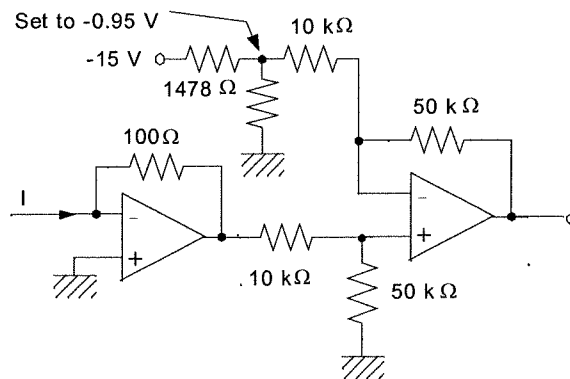

2.38

First we get an equation relating V_{out} and R from the equation for a straight line,

$$V_{out} = mR + V_0$$

Using the required relations,

$$-2 = 25000m + V_0$$

$$+2 = 1500m + V_0$$

Solving we find, $m = -1.70 \times 10^{-4}$ and $V_0 = 2.255$

so,

$$V_{out} = -1.7 \times 10^{-4} R + 2.255$$

This equation can be satisfied by an inverting amplifier with R in the op amp feedback and a summing amplifier to provide the offset voltage. The current in the sensor resistor, R , must be kept below a limit so that the dissipation does not exceed 2.5 mW. This is provided by making the input resistance and fixed input voltage within certain limits since the current through the feedback resistor is the same as the current through the input resistor.

$$P_{max} = 0.0025 \text{ W} = I^2 \times R_{min}$$

$$I = [0.0025/1500]^{1/2} = 1.3 \text{ mA}$$

So, let's use an input current of 1 mA to be sure. In the circuit below the input divider voltage is -1 volt and the input resistor is 1 kΩ so that the fixed input current is 1 mA as required.

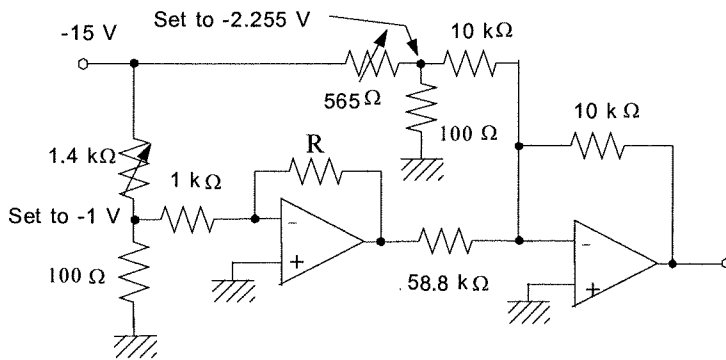

2.39

As the pressure varies from 50 to 150 psi the sensor voltage will vary from (50 psi)(100 mV/psi) = 5 volts to (150 psi)(100 mV/psi) = 15 volts. The signal conditioning must convert this into 0 to 2.5 volts,

$$0 = 5m + V_0$$

$$2.5 = 15m + V_0$$

solving,

$$m = 0.25 \text{ and } V_0 = -1.25$$

The equation for the signal conditioning is thus, $V_{out} = 0.25V_{in} - 1.25 = 0.25(V_{in} - 5)$

This can be provided by a differential amplifier with a fixed 5 volts on one input. Voltage followers are used to avoid loading the source because of its relatively low 2.5 kΩ output resistance.

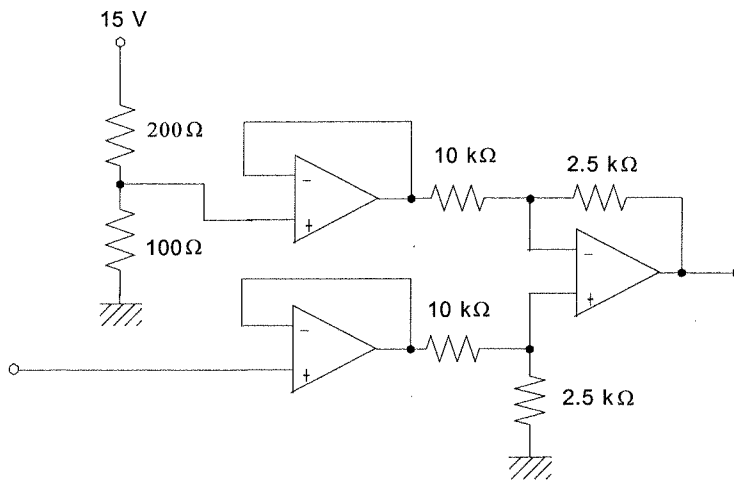

2.40

From the known static transfer function of $1.45Q^{1/2}$ the output voltage range can be found as,

$$\text{For } Q_1 = 20 \text{ gal/min, } V_1 = 1.45[20]^{1/2} = 6.48 \text{ volts}$$

$$\text{For } Q_2 = 30 \text{ gal/min, } V_2 = 1.45[30]^{1/2} = 7.94 \text{ volts}$$

Since the output resistance is only 2 kΩ, we will need a voltage follower on the output of the sensor. The basic period of the signal is 30 s or a frequency of 0.033 Hz, which is 1800 times the noise frequency of 60 Hz. Thus a simple RC low pass filter can be used to attenuate the 60 Hz noise by, say, 99%, while having very little effect on the data. We find the critical frequency from,

$$0.01 = 1/[1 + (60/f_c)^2]^{1/2} \text{ then, squaring and inverting gives,}$$

$$10000 = 1 + (60/f_c)^2 \text{ and so solving}$$

for the critical frequency gives, $f_c = 0.6 \text{ Hz}$.

Ok, to find the signal conditioning to provide the required -2.5 to +2.5 volt output we first find the filter output at 20 and 30 gal/min.

$V_{1in} = 6.48/[1 + (0.033/0.6)^2]^{1/2} = 6.47$ volts
 $V_{2in} = 7.94/[1 + (0.033/0.6)^2]^{1/2} = 7.93$ volts
 so, the signal conditioning equation will be,

$$V_{out} = mV_{in} + V_0$$

and,

$$-2.5 = 6.47m + V_0$$

$$2.5 = 7.93m + V_0$$

These equations give solutions of $m = 3.42$ and $V_0 = 24.63$ V. So we can write,

$$V_{out} = 3.42(V_{in} - 7.2)$$

The following circuit shows how the requirements of the problem can be easily satisfied.

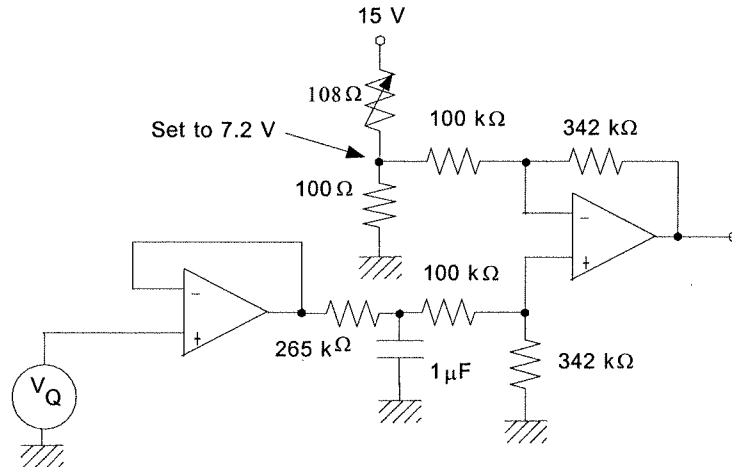

The 0.8 vrms comes out of the filter as,

$0.8/[1 + (60/0.6)^2]^{1/2} = 0.008$ volts. The full scale output voltage range is 5.0 volts so the percent FS of the noise on the output is,

$$(0.008/5) \times 100 = 0.16\%$$

The following graph shows the output plotted against flow. Obviously there is nonlinearity because the voltage and flow are related by a square-root.

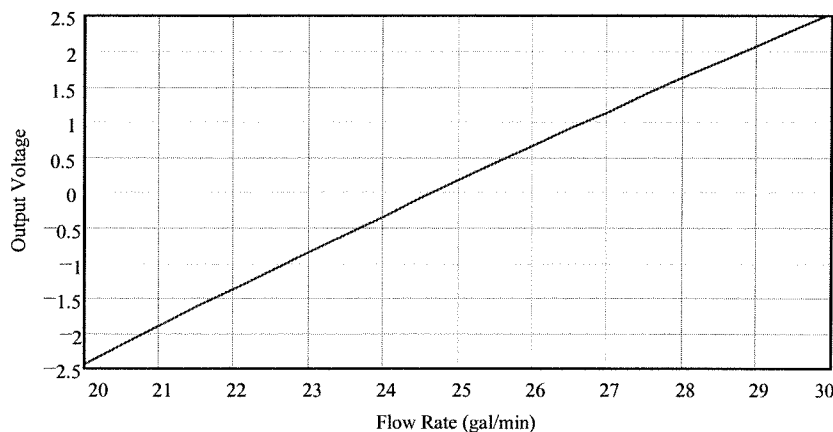

Supplementary Problems

S2.1

Round-off errors can contribute significant errors in problems like this. We will use four significant figures for all calculations.

(a) Ok, when the weight is 0.00 lbs the sensor resistance is 119 Ω. So, from the bridge null equation we can determine the correct value for the leg with R_x , call it R_1 ,

$$119R_1 = 120^2 \quad \text{so } R_1 = 120^2/119 = 121.0 \Omega$$

Now we set this equal to the equivalent resistance of everything in that leg,

$$121.0 = 100 + \frac{24(R_z + 70)}{24 + R_z + 70}$$

$$21.0 = \frac{24R_z + 1680}{R_z + 94}$$

Solving this for the unknown gives, $R_z = 98.00 \Omega$

(b) Again, the bridge null equation is used, but now we solve for R_w ,

$$R_w = \frac{120^2}{R_1} = \frac{120^2}{100 + \frac{24(R_z + 70)}{R_z + 94}}$$

where R_z varies from 0 to 200 Ω . Therefore we find

$$\text{When } R_z = 0 \Omega, \quad R_w = 122.2 \Omega$$

$$\text{When } R_z = 200 \Omega, \quad R_w = 118.0 \Omega$$

(c) When the weight is 299 lbs the sensor resistance is 127 Ω and if it is nulled at 0.00 lbs then $R_z = 98.00 \Omega$. So, we use the bridge off-null equation to find the voltage,

$$\Delta V = 5.1 \left[\frac{120}{120 + R_1} - \frac{R_w}{R_w + 120} \right]$$

$$\Delta V = 5.1 \left[\frac{120}{120 + 100 + \frac{24(70 + 98)}{98 + 94}} - \frac{127}{127 + 120} \right] = -0.0828\text{V}$$

where the negative just results from whether we subtract bridge voltage a from b or vice versa.

S2.2

(a) Well, shucks, the previous problem found that the bridge voltage at 299 lbs was 0.0828 volts so if we want a reading of 2.99 the gain must be, $K = 2.99/0.0828 = 3.1$

(b) The following differential amplifier will provide the required gain. Notice that for the output to

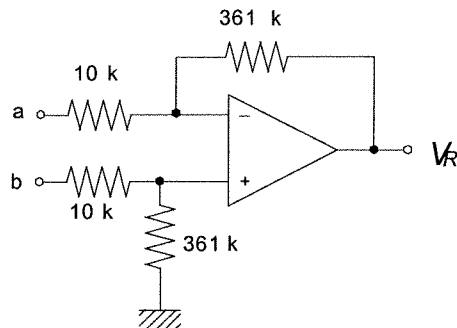

have the correct polarity we connect bridge point a to the upper amplifier input.

S2.3

(a) Well, the resistance changes linearly from 119 to 127 Ω as the weight changes from 0 to 299 lbs so the resistance at 150 lbs can be found from a simple linear relationship,

$$R_{150} = 119 + \frac{127 - 119}{299 - 0} (150 - 0) = 123.0 \Omega$$

The bridge off-null voltage will be: (assuming $R_z = 98.00 \Omega$),

$$\Delta V = 5.1 \left[\frac{123}{123 + 121} - \frac{120}{120 + 121} \right] = 0.04206 \text{ V}$$

So the DVM will read, $V_{150} = 36.1(0.04206) = 1.518$ so the DVM would read 151. Thus there is a 1 pound error.

(b) For the reading to be accurate at 150 lb requires a different gain,

$$K = 1.50/0.04206 = 35.7$$

If this gain is used the voltage at 0.0 lbs will be,

$$V_o = (35.7)(5.1) \left[\frac{119}{119 + 120} - \frac{120}{120 + 121} \right] = -.003 = 0.00 \text{ (DVM)}$$

so there is no error for 0.0 lbs. For 299 lbs we have,

$$V_{299} = (35.7)(5.1) \left[\frac{127}{127 + 120} - \frac{120}{120 + 121} \right] = 2.958 = 2.96 \text{ (DVM)}$$

So there is a -3 lb error at the high end.

(c) The following figure shows the slight nonlinearity of the readout.

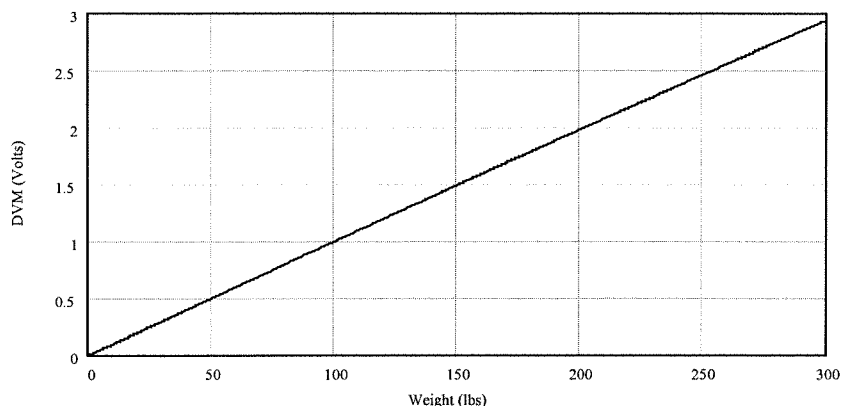

S2.4

We can simply use a low pass filter to block passage of the 50-55 kHz signal from one channel and a high pass filter to block the 1-1.5 kHz from another channel:

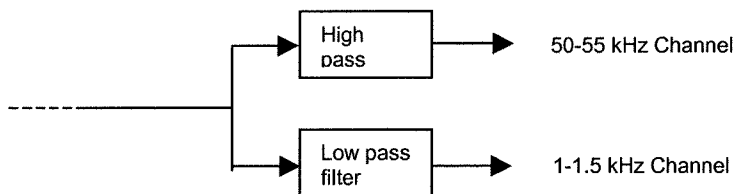

In both filters the critical frequencies are determined by the requirement that the signal be down no more than 3 dB (0.707). Thus we form the equations, (all frequencies in kHz)

$$0.707 = \frac{50/f_H}{\sqrt{1+(50/f_H)^2}} \quad \text{and} \quad 0.707 = \frac{1}{\sqrt{1+(1.5/f_L)^2}}$$

These are solved for the critical frequencies, OR, we simple recall that the critical frequencies ARE those frequencies for which the output is down 3 dB. In either case we find $f_H = 50$ kHz and $f_L = 1.5$ kHz

For the high pass we have $R_H C_H = 3.183 \times 10^{-6}$. If we pick $C_H = 0.001 \mu\text{F}$ then $R_H = 3.183$ k Ω . Similarly we find $R_L C_L = 1.061 \times 10^{-4}$ so if we pick $C_L = 0.1 \mu\text{F}$ then $R_L = 1.061$ k Ω .

The maximum effects of the cross-over will be at 50 kHz for the low pass and 1.5 kHz for the high pass. Using the high and low pass equations we find,

$$\left| \frac{V_{out}}{V_{in}} \right|_{50} = \frac{1}{\sqrt{1+(50/1.5)^2}} = 0.03 \quad \text{and} \quad \left| \frac{V_{out}}{V_{in}} \right|_{1.5} = \frac{(1.5/50)}{\sqrt{1+(1.5/50)^2}} = 0.03$$

So, for both channels the cross-over leaves about 3% of the other signal amplitude.

S2.5

We start by forming an equation between the required output voltage and the sensor resistance,

$$V = mR_s + V_0$$

The slope and intercept can be found from the two conditions of the problem;

$$0.0 = (250 \text{ k}\Omega)m + V_0$$

$$1.0 = (120 \text{ k}\Omega)m + V_0$$

Subtracting the first from the second gives, $1.0 = (130 \text{ k}\Omega)m$ or $m = -1/130 \text{ k}\Omega$. The first equation then gives, $V_0 = 250/130 = 1.923$. So we have,

$$V = -R_s/130 \text{ k}\Omega + 1.923$$

There are several ways we could provide this but the most obvious is an inverting amplifier for the first term with the sensor in the feedback and then a summing or differential amplifier to provide the 1.923 V bias.

The following circuit shows how the inverting amplifier can provide the form of the first term of the equation,

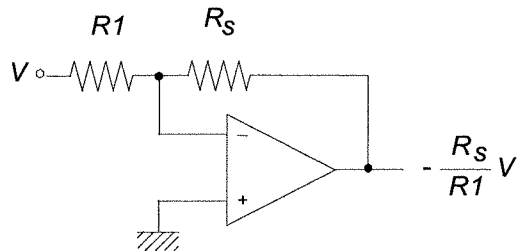

where we require, $(V/R1) = 1/130$. We also must satisfy the requirement of power dissipation below $100 \mu\text{W}$ in the sensor. This means a limitation on the current through the sensor, which is the same as the current through $R1$, $I = V/R1$. The power dissipated by the sensor is $I^2 R_s$ so we can form an equation for the current as, $I < (100 \mu\text{W}/R_s)^{1/2}$. The minimum current should be used, which occurs for maximum sensor resistance. Therefore we stipulate $I < (100 \mu\text{W}/250 \text{ k}\Omega)^{1/2} = 20 \mu\text{A}$. Thus two conditions must be satisfied, $(V/R1) = 1/130$ and $(V/R1) < 20 \mu\text{A}$. Many combinations can provide this but notice that if we set $V = 1$ volt and $R1 = 130 \text{ k}\Omega$ then $I = 7.7 \mu\text{A}$ which well satisfies the power requirement. This then is followed by a differential amplifier to provide the 1.923 V bias. In order to make the polarities come out correct we used $V = -1$ volt. The following circuit shows the completed design.

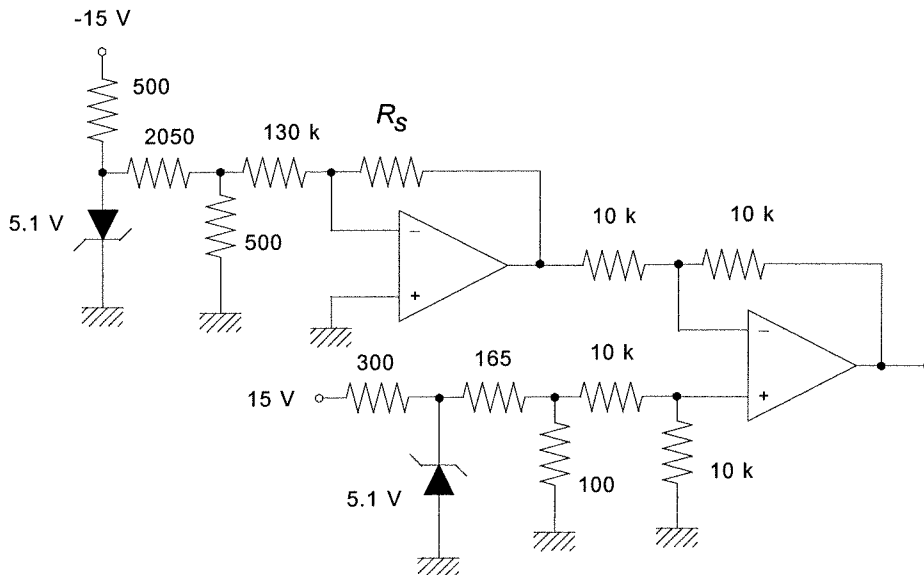

S2.6

As long as the input voltage is less than 1.4 volts the feedback resistance is $100 \text{ k}\Omega$ and so the gain is given by -1 and the output is simply, $V_{out} = -V_{in}$. When the input (and therefore output) reaches 1.4 volts $D1$ begins to conduct so that the feedback resistance changes to $50 \text{ k}\Omega$ (two $100 \text{ k}\Omega$ in parallel). Now the gain drops to $-1/2$ so the output is, $V_{out} = -1.4 - (V_{in} - 1.4)/2 = -0.7 - V_{in}/2$. As the input voltage continues to rise and output will go more negative. When the output reaches -

2.8 volts the 50 kΩ resistor in the feedback will be in parallel with the others and the gain will become -1/4. We find the value of input when this occurs from: $-2.8 = -0.7 - V_{in}/2$ or $V_{in} = 4.2$ volts. Now the equation for the output becomes, $V_{out} = -2.8 - (V_{in} - 4.2)/4 = -1.75 - V_{in}/4$. The following figure shows a plot of output voltage versus input voltage.

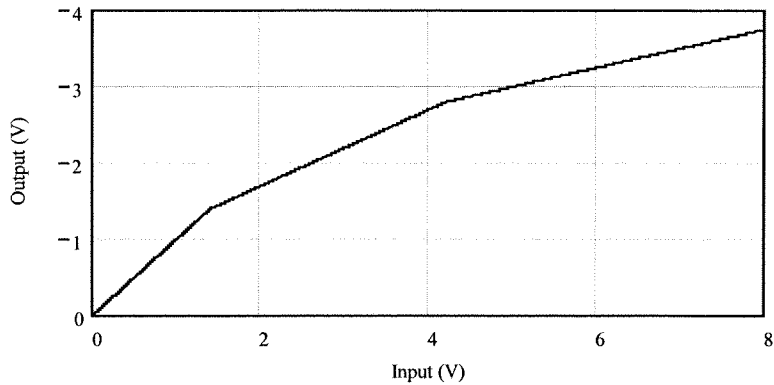

S2.7

First we find the "breaks" in pressure when the gain changes. The first is at 1.4 volts, so we have

$$p_1 = (1.4/0.035)^{1/2} = 6.32 \text{ psi}$$

The second is for

$$p_2 = (4.2/0.035)^{1/2} = 10.95 \text{ psi}$$

Thus the equations for output are:

$$p < 6.32 \quad V_{out} = -0.035p^2$$

$$10.95 > p > 6.32 \quad V_{out} = -1.4 - .035p^2/2 = -1.4 - 0.0175p^2$$

$$p > 10.95 \quad V_{out} = -1.75 - 0.035p^2/4 = -1.75 - 0.00875p^2$$

This result is plotted below. Notice that the output voltage is more nearly linear.

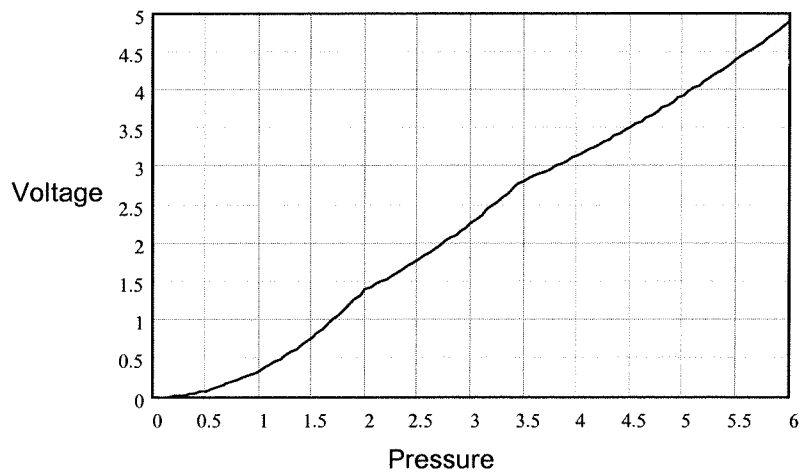

CHAPTER 3

3.1

The basic relations for conversions of binary are defined for a binary, $b_n b_{n-1} \dots b_1 b_0$ where the b 's are either a 1 or 0, then,

$$N_{10} = a_n 2^n + a_{n-1} 2^{n-1} + \dots + a_1 2^1 + a_0 2^0$$

For octal we just arrange the binary number in three-bit groups starting from the decimal point and use the relations

$$111 = 7_8, 110 = 6_8, \text{ etc, } 001 = 1_8 \text{ and } 000 = 0_8$$

For hex we use groupings of four and include the numbers,

$$1000 = 8H, 1001 = 9H, 1010 = AH, 1011 = BH, 1100 = CH$$

$$1101 = DH, 1110 = EH \text{ and } 1111 = FH$$

so,

(a) $1010 \Rightarrow 2^3 + 2^1 = 8 + 2 = 10_{10}$

$$1010 = 001\ 010 \Rightarrow 12_8$$

$$1010 \Rightarrow AH$$

(b) $111011 \Rightarrow 2^5 + 2^4 + 2^3 + 2^1 + 2^0 = 32 + 16 + 8 + 2 + 1 = 59_{10}$

$$111011 = 111\ 011 \Rightarrow 73_8$$

$$111011 = 0011\ 1011 \Rightarrow 3BH$$

(c) $010110 \Rightarrow 2^4 + 2^2 + 2^1 = 16 + 4 + 2 = 22_{10}$

$$010110 = 010\ 110 \Rightarrow 26_8$$

$$010110 = 0001\ 0110 \Rightarrow 16H$$

3.2

(a) $1011010 \Rightarrow 2^6 + 2^4 + 2^3 + 2^1 = 64 + 16 + 8 + 2 = 90_{10}$

$$1011010 = 001\ 011\ 010 \Rightarrow 132_8$$

$$1011010 = 0101\ 1010 \Rightarrow 5AH$$

(b) For this we must use the base 10 fractional to binary fractional relationship,

Given a binary fraction, $0.b_1 b_2 \dots b_n$ then,

$$0.N_{10} = b_1 2^{-1} + b_2 2^{-2} + \dots + b_n 2^{-n}$$

Octal and Hex fractionals are found by the regular 3 and 4 groupings of bits. So,

$$0.1101 \approx 2^{-1} + 2^{-2} + 2^{-4}$$

$$= 0.5 + 0.25 + 0.0625 = 0.8125_{10}$$

$$0.1101 = 0.110\ 100 \Rightarrow 0.64_8$$

$$0.1101 \Rightarrow 0.DH$$

(c) 1011.0110 treating the whole and fractional parts separately,

$$1011 \Rightarrow 2^3 + 2^1 + 2^0 = 8 + 2 + 1 = 11_{10} \text{ and } 0.0110 \Rightarrow 2^{-2} + 2^{-3} = 0.25 + 0.125 = 0.375_{10}$$

$$\text{thus, } 1011.0110 \Rightarrow 11.375_{10}$$

$$1011.0110 = 001\ 011.011\ 000 \Rightarrow 13.3_8$$

$$1011.0110 \Rightarrow B.6H$$

3.3

If we find the binary first then the octal and hex can be found easily using the groupings of 3 and 4 bits.

(a) $21/2 = 10 + 1/2$ so $b_0 = 1$

$$10/2 = 5 + 0$$
 so $b_1 = 0$

$$5/2 = 2 + 1/2$$
 so $b_2 = 1$ $2/2 = 1 + 0$ so $b_3 = 0$

$$1/2 = 0 + 1/2$$
 so $b_4 = 1$ so $21_{10} \Rightarrow 10101_2$

and, $10101 = 010\ 101 \Rightarrow 25_8$

$$10101 = 0001\ 0101 \Rightarrow 15H$$

(b) Lets do successive division by 8 instead to find the octal first,

$$630/8 = 78 + 6/8$$
 so $d_0 = 6$

$$78/8 = 9 + 6/8$$
 so $d_1 = 6$

$$9/8 = 1 + 1/8$$
 so $d_2 = 1$

$$1/8 = 1 + 0/8$$
 so $d_3 = 1$

$$630_{10} \Rightarrow 1166_8$$

using binary groupings we see that,

$$1166_8 \Rightarrow 001\ 001\ 110\ 110 = 100110110_2 \text{ and,}$$

$$1001110110 = 0010\ 0111\ 0110 \Rightarrow 276H$$

(c) On this one lets successively divide by 16 to get the hex first,

$$427/16 = 26 + 11/16 \quad \text{so } a_1 = 11_{10} = BH$$

$$26/16 = 1 + 10/16 \quad \text{so } a_2 = 10_{10} = AH$$

$$1/16 = 0 + 1/16 \quad \text{so } a_3 = 1$$

$$427_{10} = 1ABH$$

Using groupings we get the binary and then the octal,

$$1ABH \approx 000110101011 = 110101011_2 \quad \text{and} \quad 110101011 = 110\ 101\ 011 \Rightarrow 653_8$$

3.4

The whole number and fractional parts are converted separately,

$$27_{10} \text{ is } 27/2 = 13 + 1/2 \quad \text{so } b_0 = 1$$

$$13/2 = 6 + 1/2 \quad \text{so } b_1 = 1$$

$$6/2 = 3 + 0 \quad \text{so } b_2 = 0$$

$$3/2 = 1 + 1/2 \quad \text{so } b_3 = 1$$

$$1/2 = 0 + 1/2 \quad \text{so } b_4 = 1$$

$$27_{10} \Rightarrow 11011_2$$

For the fractional part we do successive multiplications,

$$2 * 0.156 = 0.312 \text{ so } a_1 = 0$$

$$2 * 0.312 = 0.624 \text{ so } a_2 = 0$$

$$2 * 0.624 = 1.248 \text{ so } a_3 = 1$$

$$2 * 0.248 = 0.496 \text{ so } a_4 = 0$$

$$2 * 0.496 = 0.992 \text{ so } a_5 = 0$$

$$2 * 0.992 = 1.984 \text{ so } a_6 = 1$$

we stop here because that is 6-bits.

$$0.156_{10} \Rightarrow 0.001001 \text{ (to 6-bits)}$$

The entire number then is,

$$27.156 \Rightarrow 11011.001001 \text{ (to 6-bits fractional) The actual fractional value is,}$$

$$0.001001 = 2^{-3} + 2^{-6} = 0.140625_{10}$$

3.5

a) complement of 1011 = 0100

$$\begin{array}{r} \\ + 1 \\ \hline 2\text{'s complement: } 0101 \end{array}$$

(b) complement of 10101100 = 01010011

$$\begin{array}{r} \\ + 1 \\ \hline 2\text{'s complement } 01010100 \end{array}$$

3.6

Prove $\overline{A \bullet B} = \overline{A} + \overline{B}$

A	B	$\overline{A \bullet B}$	$\overline{A} + \overline{B}$
0	0	1	1
1	0	1	1
0	1	1	1
1	1	0	0

3.7

Let

$$F = A \bullet B + A \bullet (\overline{A \bullet B})$$

$$F = A \bullet B + A \bullet (\overline{A} + \overline{B})$$

$$F = A \bullet B + A \bullet \overline{A} + A \bullet \overline{B} \quad \text{but } A \bullet \overline{A} = 0$$

$$F = A \bullet (B + \overline{B}) \quad \text{but } B + \overline{B} = 1$$

$$F = A$$

3.8

For (a) we have an alarm when speed (S) is low, weight (W) is high and loading rate (R) is high,

$$\bar{S} \cdot W \cdot R$$

(b) speed is high and loading rate is low, $S \cdot \bar{R}$
 The combination is OR'ed to give,

$$A = \bar{S} \cdot W \cdot R + S \cdot \bar{R}$$

3.9

The equation above is implemented as follows,

(a) AND/OR logic

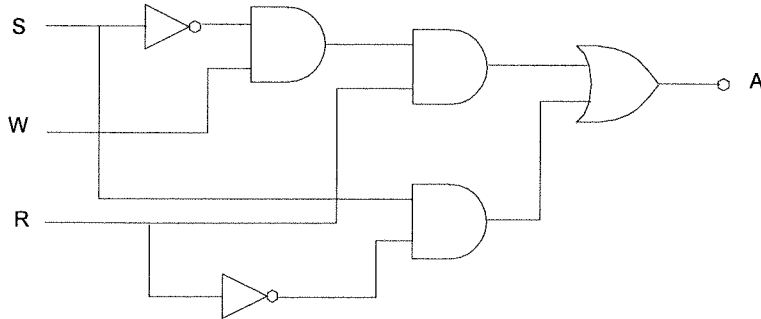

(b) in NAND/NOR logic we have,

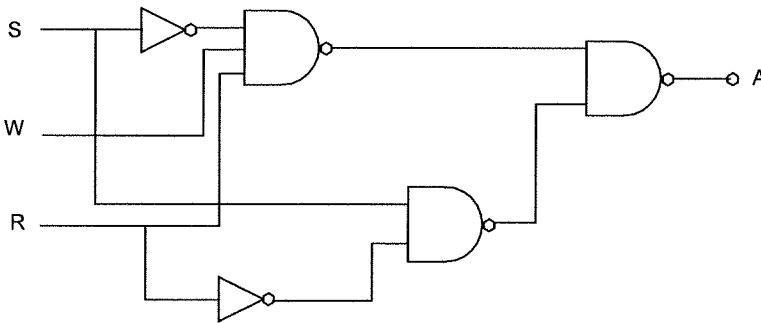

3.10

We simply translate the statements directly into Boolean expressions

a. OV: 1. $(QA + QB) \cdot \bar{QC} \cdot L \cdot \bar{P}$

2. $QA \cdot QB \cdot \bar{QC} \cdot \bar{P}$

thus,

$$OV = (QA + QB) \cdot \bar{QC} \cdot L \cdot \bar{P} + QA \cdot QB \cdot \bar{QC} \cdot \bar{P}$$

b. EP: 1. $\bar{QA} \cdot \bar{QB} \cdot \bar{L} \cdot QC$

2. $(\bar{QA} + \bar{QB}) \cdot QC \cdot P$

thus,

$$EP = \bar{QA} \cdot \bar{QB} \cdot \bar{L} \cdot QC + (\bar{QA} + \bar{QB}) \cdot QC \cdot P$$

3.11

The following logic circuits will provide the needed alarms.

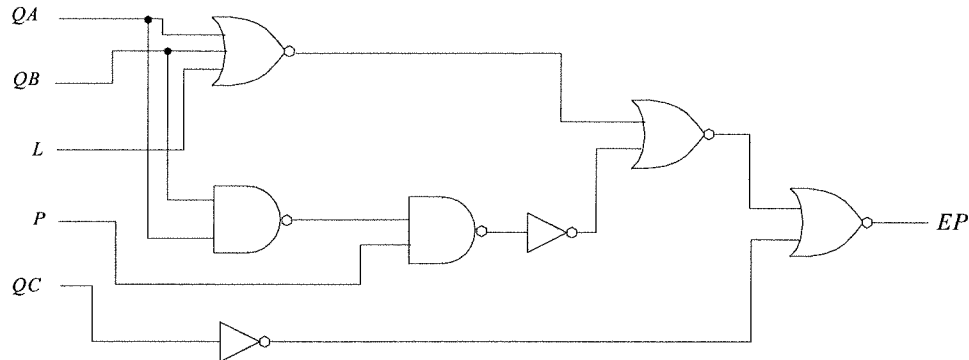
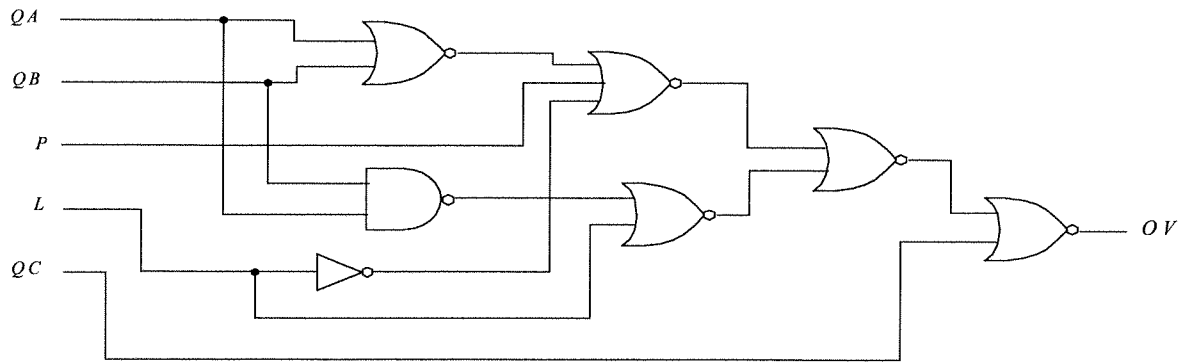

3.12

If the transfer function is $360 \mu\text{V}/^\circ\text{C}$ then a temperature of 530°C will result in an output voltage of,
 $V = (360 \times 10^{-6} \text{ V}/^\circ\text{C})(530^\circ\text{C})$

$$V = 0.1908 \text{ volts or } 0.191 \text{ to three significant figures.}$$

We can construct a divider from a +5 volt supply to obtain this required alarm voltage for the comparator. One possible circuit then is,

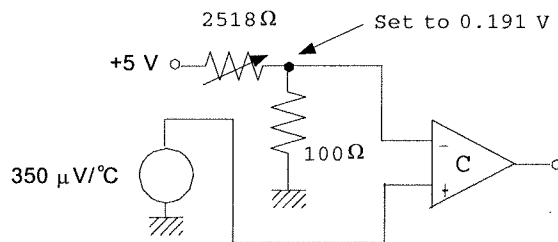

3.13

Using the transfer function of $0.04 \text{ V}/(\text{W}/\text{m}^2)$ we find the required comparator trigger voltage is,

$$V = (0.04 \text{ V}/(\text{W}/\text{m}^2))(30 \text{ W}/\text{m}^2)$$

$$V = 1.2 \text{ V}$$

and the noise provides a voltage fluctuation of,

$$\Delta V = (\pm 1.6 \text{ W}/\text{m}^2)(0.04 \text{ V}/(\text{W}/\text{m}^2))$$

$$\Delta V = \pm 64 \text{ mV}$$

We will provide a window of 128 mV about the trigger value of 1.2 V. This will be done by making the comparator go high when the signal plus noise is $(1.2 + .064) \text{ V} = 1.264 \text{ V}$ and return low when the output falls to $(1.2 - .064) \text{ V} = 1.136 \text{ V}$. Thus,

$$V_H = V_{ref} = 1.264 \text{ and}$$

$$V_L = V_{ref} - (R/R_f)V_0$$

$$1.136 = 1.264 - (R/R_f)(5 \text{ V})$$

$$(R/R_f) = 0.0256$$

Let's pick $R_f = 100 \text{ k}\Omega$ then $R = 2.56 \text{ k}\Omega$. The circuit of Figure 3.9 is used with a divider as in Figure 2.4 to develop the required reference voltage. The divider will have $V_s = 5.0 \text{ V}$, $R_1 = 295.6 \Omega$ and $R_2 = 100 \Omega$.

3.14

The hysteresis comparator is given in Figure 3.9. Dividers such as Figure 2.4 can be used to provide the required reference voltages. We pick a feedback resistor of $1 \text{ M}\Omega$ for all comparators. If the window is to be 1% of the reference value and the supply is to be five volts then the input resistance can be expressed as,

$$R = R_f \Delta V / V_0 = (1 \text{ M}\Omega)(0.01)V_{ref}/5 = 2000V_{ref} \Omega$$

We assume the dividers are derived from a five volt source with a 100Ω grounding resistor. Then the necessary resistance for the required reference is found from the divider equation as,

$$V_D = R_2 V_0 / (R_1 + R_2), \text{ but with } V_D = V_{ref}, V_0 = 5 \text{ V and } R_2 = 100 \Omega, \text{ we solve for } R_1 \text{ as,}$$

$$R_1 = 500 / V_{ref} - 100$$

So, we can now construct all the required values,

QA:	$V_{ref} = 0.15[55]^{1/2} = 1.11 \text{ V}$	$R = 2222 \Omega$	$R_1 = 350.5 \Omega$
QB:	$V_{ref} = 0.15[30]^{1/2} = 0.82 \text{ V}$	$R = 1640 \Omega$	$R_1 = 509.8 \Omega$
QC:	$V_{ref} = 0.15[100]^{1/2} = 1.5 \text{ V}$	$R = 3000 \Omega$	$R_1 = 233.3 \Omega$
P:	$V_{ref} = 20/(120 + 20) = 0.14 \text{ V}$	$R = 280 \Omega$	$R_1 = 3471 \Omega$
L:	$V_{ref} = .05(3.6) = 0.18 \text{ V}$	$R = 360 \Omega$	$R_1 = 2678 \Omega$

All of the circuits have the following form with values from the table above.

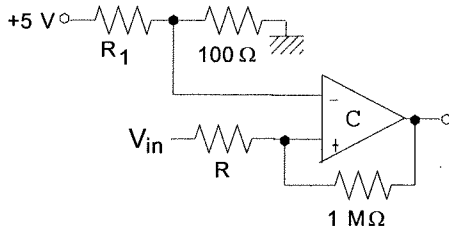

3.15

Let us define Boolean variables, TH and TL which will be high when the temperature exceeds 40 and $50 \text{ }^\circ\text{C}$ respectively. Similarly, QH and QL will be high when the flow exceeds 2 and 3 L/min . Now we can form a Boolean expression for the output, OUT ,

$$OUT = TL \cdot TH \cdot QL \cdot QH$$

Comparators can be used to generate the Boolean logic signals by assigning reference voltages found from the transfer functions of the sensors. The resistive sensor will be placed in a divider to convert the resistance to a voltage.

$$TH: R_{TH} = 1000e^{-.05(50-25)} = 286.5 \Omega$$

$$TL: R_{TL} = 1000e^{-.05(40-25)} = 472.4 \Omega$$

$$QH: V_{QH} = 5/(3+5) = 0.625 \text{ V}$$

$$QL: V_{QL} = 5/(2+5) = 0.714 \text{ V}$$

For the resistive sensor lets use a divider with a 500Ω resistor and use the five volt supply. We use the sensor in the upper resistor so the voltage will rise with increasing flow. Then the appropriate temperature reference voltages are:

$$V_{TH} = 5(500)/(500 + 286.5) = 3.18 \text{ V}$$

$$V_{TL} = 5(500)/(500 + 472.4) = 2.57 \text{ V}$$

Once the sensor signals are converted to Boolean by the comparator we use inverters and gates to implement the above Boolean equation. The result is given below.

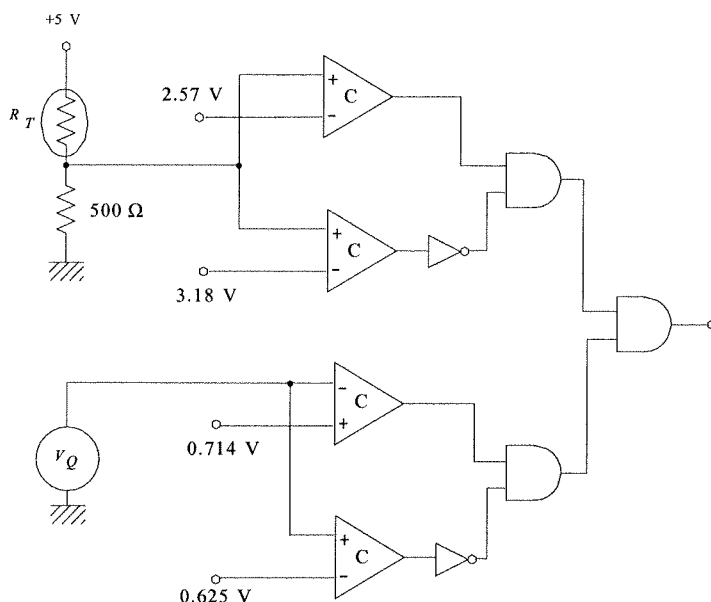

3.16

For the 6-bit DAC with a 100101₂ input and a 10 volt reference we have,

(a) the output is given by,

$$V_{out} = 10(2^{-1} + 2^{-4} + 2^{-6})$$

$$= 10(0.578125)$$

$$= 5.78125 \text{ V}$$

(b) the resolution is $\Delta V = V_{ref}2^{-n}$ so,

$$\Delta V = (10)(2^{-6})$$

$$= 0.15625 \text{ V}$$

3.17

Well, we have $V_{max} = V_{ref}(2^{-1} + 2^{-2} + 2^{-3} + 2^{-4})$

$$8 = V_{ref}(0.5 + 0.25 + 0.125 + 0.0625) \text{ so } V_{ref} = 8.533 \text{ V}$$

3.18

(a) The minimum output of the 8-bit DAC is 0.0 volts so the minimum intensity is obviously 0.0 W/m². For the maximum we note that the maximum output of the DAC is, $(255/256)5.00 = 4.9805 \text{ V}$. Thus the maximum intensity is,

$$45(4.9805)^{3/2} = 500 \text{ W/m}^2$$

(b) The intensity output for the given hex values is determined by finding the DAC voltage output and then using it in the transfer function of the source. Combining allows an equation for intensity versus the decimal equivalent of the hex number,

$$I_L = 45[(N/256)5.00]^{(3/2)}$$

HEX	N	Intensity (W/m ²)
1B	27	17.2
7A	122	165.5
9F	159	246.2
E5	229	425.7

(c) Of course since the DAC voltage is linearly related to the HEX input but the intensity is non-linearly related to the voltage we expect a nonlinear relation between HEX and intensity. Indeed, as the following graph shows, the relation is nonlinear.