

Solutions Manual for
Thermodynamics: An Engineering Approach
8th Edition
Yunus A. Cengel, Michael A. Boles
McGraw-Hill, 2015

Chapter 2

ENERGY, ENERGY TRANSFER, AND GENERAL ENERGY ANALYSIS

PROPRIETARY AND CONFIDENTIAL

This Manual is the proprietary property of McGraw-Hill Education and protected by copyright and other state and federal laws. By opening and using this Manual the user agrees to the following restrictions, and if the recipient does not agree to these restrictions, the Manual should be promptly returned unopened to McGraw-Hill Education: **This Manual is being provided only to authorized professors and instructors for use in preparing for the classes using the affiliated textbook. No other use or distribution of this Manual is permitted. This Manual may not be sold and may not be distributed to or used by any student or other third party. No part of this Manual may be reproduced, displayed or distributed in any form or by any means, electronic or otherwise, without the prior written permission of McGraw-Hill Education.**

Forms of Energy

2-1C The sum of all forms of the energy a system possesses is called *total energy*. In the absence of magnetic, electrical and surface tension effects, the total energy of a system consists of the kinetic, potential, and internal energies.

2-2C The internal energy of a system is made up of sensible, latent, chemical and nuclear energies. The sensible internal energy is due to translational, rotational, and vibrational effects.

2-3C Thermal energy is the sensible and latent forms of internal energy, and it is referred to as heat in daily life.

2-4C The *mechanical energy* is the form of energy that can be converted to mechanical work completely and directly by a mechanical device such as a propeller. It differs from thermal energy in that thermal energy cannot be converted to work directly and completely. The forms of mechanical energy of a fluid stream are kinetic, potential, and flow energies.

2-5C Hydrogen is also a fuel, since it can be burned, but it is not an energy source since there are no hydrogen reserves in the world. Hydrogen can be obtained from water by using another energy source, such as solar or nuclear energy, and then the hydrogen obtained can be used as a fuel to power cars or generators. Therefore, it is more proper to view hydrogen is an energy carrier than an energy source.

2-6C In electric heaters, electrical energy is converted to sensible internal energy.

2-7C The forms of energy involved are electrical energy and sensible internal energy. Electrical energy is converted to sensible internal energy, which is transferred to the water as heat.

2-8E The total kinetic energy of an object is given is to be determined.

Analysis The total kinetic energy of the object is given by

$$KE = m \frac{V^2}{2} = (10 \text{ lbm}) \frac{(50 \text{ ft/s})^2}{2} \left(\frac{1 \text{ Btu/lbm}}{25,037 \text{ ft}^2/\text{s}^2} \right) = 0.499 \text{ Btu} \cong \mathbf{0.50 \text{ Btu}}$$

2-9E The total potential energy of an object is to be determined.

Analysis Substituting the given data into the potential energy expression gives

$$PE = mgz = (200 \text{ lbm})(32.2 \text{ ft/s}^2)(10 \text{ ft}) \left(\frac{1 \text{ Btu/lbm}}{25,037 \text{ ft}^2/\text{s}^2} \right) = \mathbf{2.57 \text{ Btu}}$$

2-10 A person with his suitcase goes up to the 10th floor in an elevator. The part of the energy of the elevator stored in the suitcase is to be determined.

Assumptions 1 The vibrational effects in the elevator are negligible.

Analysis The energy stored in the suitcase is stored in the form of potential energy, which is mgz . Therefore,

$$\Delta E_{\text{suitcase}} = \Delta PE = mg\Delta z = (30 \text{ kg})(9.81 \text{ m/s}^2)(35 \text{ m}) \left(\frac{1 \text{ kJ/kg}}{1000 \text{ m}^2/\text{s}^2} \right) = \mathbf{10.3 \text{ kJ}}$$

Therefore, the suitcase on 10th floor has 10.3 kJ more energy compared to an identical suitcase on the lobby level.

Discussion Noting that 1 kWh = 3600 kJ, the energy transferred to the suitcase is $10.3/3600 = 0.0029$ kWh, which is very small.

2-11 A hydraulic turbine-generator is to generate electricity from the water of a large reservoir. The power generation potential is to be determined.

Assumptions 1 The elevation of the reservoir remains constant.

2 The mechanical energy of water at the turbine exit is negligible.

Analysis The total mechanical energy water in a reservoir possesses is equivalent to the potential energy of water at the free surface, and it can be converted to work entirely. Therefore, the power potential of water is its potential energy, which is gz per unit mass, and $\dot{m}gz$ for a given mass flow rate.

$$e_{\text{mech}} = pe = gz = (9.81 \text{ m/s}^2)(120 \text{ m}) \left(\frac{1 \text{ kJ/kg}}{1000 \text{ m}^2/\text{s}^2} \right) = 1.177 \text{ kJ/kg}$$

Then the power generation potential becomes

$$\dot{W}_{\text{max}} = \dot{E}_{\text{mech}} = \dot{m}e_{\text{mech}} = (2400 \text{ kg/s})(1.177 \text{ kJ/kg}) \left(\frac{1 \text{ kW}}{1 \text{ kJ/s}} \right) = \mathbf{2825 \text{ kW}}$$

Therefore, the reservoir has the potential to generate 2825 kW of power.

Discussion This problem can also be solved by considering a point at the turbine inlet, and using flow energy instead of potential energy. It would give the same result since the flow energy at the turbine inlet is equal to the potential energy at the free surface of the reservoir.

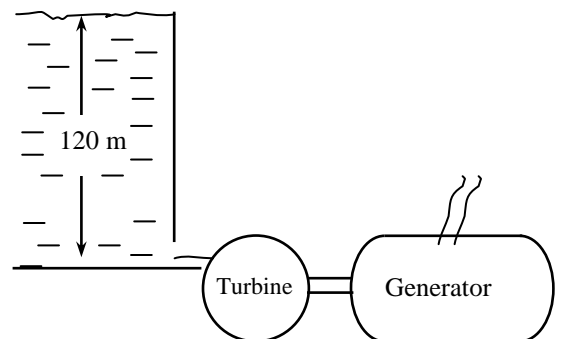

2-12 Wind is blowing steadily at a certain velocity. The mechanical energy of air per unit mass and the power generation potential are to be determined.

Assumptions The wind is blowing steadily at a constant uniform velocity.

Properties The density of air is given to be $\rho = 1.25 \text{ kg/m}^3$.

Analysis Kinetic energy is the only form of mechanical energy the wind possesses, and it can be converted to work entirely. Therefore, the power potential of the wind is its kinetic energy, which is $V^2/2$ per unit mass, and $\dot{m}V^2/2$ for a given mass flow rate:

$$e_{\text{mech}} = ke = \frac{V^2}{2} = \frac{(10 \text{ m/s})^2}{2} \left(\frac{1 \text{ kJ/kg}}{1000 \text{ m}^2/\text{s}^2} \right) = 0.050 \text{ kJ/kg}$$

$$\dot{m} = \rho VA = \rho V \frac{\pi D^2}{4} = (1.25 \text{ kg/m}^3)(10 \text{ m/s}) \frac{\pi (60 \text{ m})^2}{4} = 35,340 \text{ kg/s}$$

$$\dot{W}_{\text{max}} = \dot{E}_{\text{mech}} = \dot{m}e_{\text{mech}} = (35,340 \text{ kg/s})(0.050 \text{ kJ/kg}) = \mathbf{1770 \text{ kW}}$$

Therefore, 1770 kW of actual power can be generated by this wind turbine at the stated conditions.

Discussion The power generation of a wind turbine is proportional to the cube of the wind velocity, and thus the power generation will change strongly with the wind conditions.

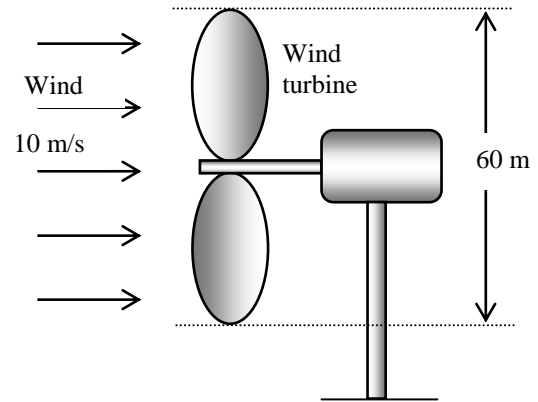

2-13 A water jet strikes the buckets located on the perimeter of a wheel at a specified velocity and flow rate. The power generation potential of this system is to be determined.

Assumptions Water jet flows steadily at the specified speed and flow rate.

Analysis Kinetic energy is the only form of harvestable mechanical energy the water jet possesses, and it can be converted to work entirely. Therefore, the power potential of the water jet is its kinetic energy, which is $V^2/2$ per unit mass, and $\dot{m}V^2/2$ for a given mass flow rate:

$$e_{\text{mech}} = ke = \frac{V^2}{2} = \frac{(60 \text{ m/s})^2}{2} \left(\frac{1 \text{ kJ/kg}}{1000 \text{ m}^2/\text{s}^2} \right) = 1.8 \text{ kJ/kg}$$

$$\begin{aligned} \dot{W}_{\text{max}} &= \dot{E}_{\text{mech}} = \dot{m}e_{\text{mech}} \\ &= (120 \text{ kg/s})(1.8 \text{ kJ/kg}) \left(\frac{1 \text{ kW}}{1 \text{ kJ/s}} \right) = \mathbf{216 \text{ kW}} \end{aligned}$$

Therefore, 216 kW of power can be generated by this water jet at the stated conditions.

Discussion An actual hydroelectric turbine (such as the Pelton wheel) can convert over 90% of this potential to actual electric power.

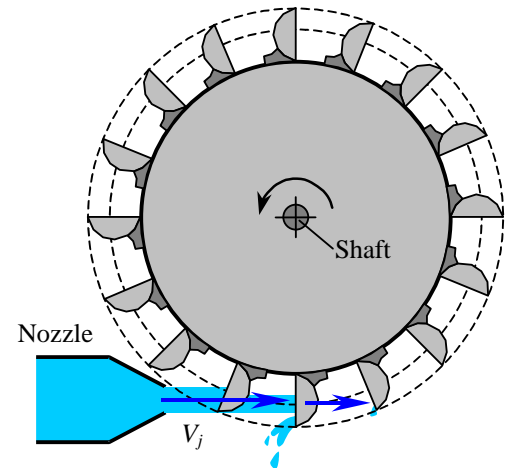

2-14 Two sites with specified wind data are being considered for wind power generation. The site better suited for wind power generation is to be determined.

Assumptions 1 The wind is blowing steadily at specified velocity during specified times. 2 The wind power generation is negligible during other times.

Properties We take the density of air to be $\rho = 1.25 \text{ kg/m}^3$ (it does not affect the final answer).

Analysis Kinetic energy is the only form of mechanical energy the wind possesses, and it can be converted to work entirely. Therefore, the power potential of the wind is its kinetic energy, which is $V^2/2$ per unit mass, and $\dot{m}V^2/2$ for a given mass flow rate. Considering a unit flow area ($A = 1 \text{ m}^2$), the maximum wind power and power generation becomes

$$e_{\text{mech},1} = ke_1 = \frac{V_1^2}{2} = \frac{(7 \text{ m/s})^2}{2} \left(\frac{1 \text{ kJ/kg}}{1000 \text{ m}^2/\text{s}^2} \right) = 0.0245 \text{ kJ/kg}$$

$$e_{\text{mech},2} = ke_2 = \frac{V_2^2}{2} = \frac{(10 \text{ m/s})^2}{2} \left(\frac{1 \text{ kJ/kg}}{1000 \text{ m}^2/\text{s}^2} \right) = 0.050 \text{ kJ/kg}$$

$$\dot{W}_{\text{max},1} = \dot{E}_{\text{mech},1} = \dot{m}_1 e_{\text{mech},1} = \rho V_1 A k e_1 = (1.25 \text{ kg/m}^3)(7 \text{ m/s})(1 \text{ m}^2)(0.0245 \text{ kJ/kg}) = 0.2144 \text{ kW}$$

$$\dot{W}_{\text{max},2} = \dot{E}_{\text{mech},2} = \dot{m}_2 e_{\text{mech},2} = \rho V_2 A k e_2 = (1.25 \text{ kg/m}^3)(10 \text{ m/s})(1 \text{ m}^2)(0.050 \text{ kJ/kg}) = 0.625 \text{ kW}$$

since $1 \text{ kW} = 1 \text{ kJ/s}$. Then the maximum electric power generations per year become

$$E_{\text{max},1} = \dot{W}_{\text{max},1} \Delta t_1 = (0.2144 \text{ kW})(3000 \text{ h/yr}) = \mathbf{643 \text{ kWh/yr}}$$
 (per m^2 flow area)

$$E_{\text{max},2} = \dot{W}_{\text{max},2} \Delta t_2 = (0.625 \text{ kW})(1500 \text{ h/yr}) = \mathbf{938 \text{ kWh/yr}}$$
 (per m^2 flow area)

Therefore, **second site** is a better one for wind generation.

Discussion Note the power generation of a wind turbine is proportional to the cube of the wind velocity, and thus the average wind velocity is the primary consideration in wind power generation decisions.

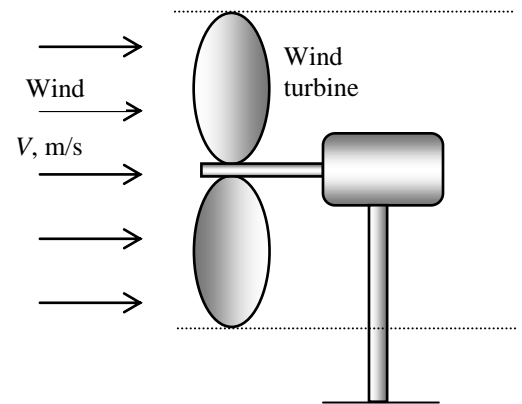

2-15 A river flowing steadily at a specified flow rate is considered for hydroelectric power generation by collecting the water in a dam. For a specified water height, the power generation potential is to be determined.

Assumptions 1 The elevation given is the elevation of the free surface of the river. **2** The mechanical energy of water at the turbine exit is negligible.

Properties We take the density of water to be $\rho = 1000 \text{ kg/m}^3$.

Analysis The total mechanical energy the water in a dam possesses is equivalent to the potential energy of water at the free surface of the dam (relative to free surface of discharge water), and it can be converted to work entirely. Therefore, the power potential of water is its potential energy, which is gz per unit mass, and $\dot{m}gz$ for a given mass flow rate.

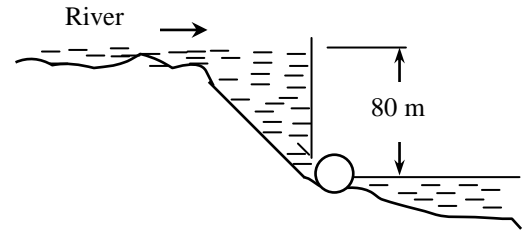

$$e_{\text{mech}} = pe = gz = (9.81 \text{ m/s}^2)(80 \text{ m}) \left(\frac{1 \text{ kJ/kg}}{1000 \text{ m}^2/\text{s}^2} \right) = 0.7848 \text{ kJ/kg}$$

The mass flow rate is

$$\dot{m} = \rho \dot{V} = (1000 \text{ kg/m}^3)(175 \text{ m}^3/\text{s}) = 175,000 \text{ kg/s}$$

Then the power generation potential becomes

$$\dot{W}_{\text{max}} = \dot{E}_{\text{mech}} = \dot{m}e_{\text{mech}} = (175,000 \text{ kg/s})(0.7848 \text{ kJ/kg}) \left(\frac{1 \text{ MW}}{1000 \text{ kJ/s}} \right) = \mathbf{137 \text{ MW}}$$

Therefore, 137 MW of power can be generated from this river if its power potential can be recovered completely.

Discussion Note that the power output of an actual turbine will be less than 137 MW because of losses and inefficiencies.

2-16 A river is flowing at a specified velocity, flow rate, and elevation. The total mechanical energy of the river water per unit mass, and the power generation potential of the entire river are to be determined.

Assumptions 1 The elevation given is the elevation of the free surface of the river. **2** The velocity given is the average velocity. **3** The mechanical energy of water at the turbine exit is negligible.

Properties We take the density of water to be $\rho = 1000 \text{ kg/m}^3$.

Analysis Noting that the sum of the flow energy and the potential energy is constant for a given fluid body, we can take the elevation of the entire river water to be the elevation of the free surface, and ignore the flow energy. Then the total mechanical energy of the river water per unit mass becomes

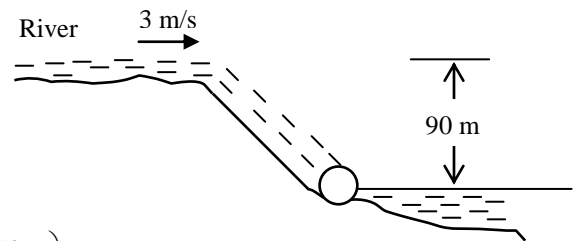

$$e_{\text{mech}} = pe + ke = gh + \frac{V^2}{2} = \left((9.81 \text{ m/s}^2)(90 \text{ m}) + \frac{(3 \text{ m/s})^2}{2} \right) \left(\frac{1 \text{ kJ/kg}}{1000 \text{ m}^2/\text{s}^2} \right) = \mathbf{0.887 \text{ kJ/kg}}$$

The power generation potential of the river water is obtained by multiplying the total mechanical energy by the mass flow rate,

$$\dot{m} = \rho \dot{V} = (1000 \text{ kg/m}^3)(500 \text{ m}^3/\text{s}) = 500,000 \text{ kg/s}$$

$$\dot{W}_{\text{max}} = \dot{E}_{\text{mech}} = \dot{m}e_{\text{mech}} = (500,000 \text{ kg/s})(0.887 \text{ kJ/kg}) = 444,000 \text{ kW} = \mathbf{444 \text{ MW}}$$

Therefore, 444 MW of power can be generated from this river as it discharges into the lake if its power potential can be recovered completely.

Discussion Note that the kinetic energy of water is negligible compared to the potential energy, and it can be ignored in the analysis. Also, the power output of an actual turbine will be less than 444 MW because of losses and inefficiencies.

Energy Transfer by Heat and Work

2-17C The form of energy that crosses the boundary of a closed system because of a temperature difference is heat; all other forms are work.

2-18C (a) The car's radiator transfers heat from the hot engine cooling fluid to the cooler air. No work interaction occurs in the radiator.

(b) The hot engine transfers heat to cooling fluid and ambient air while delivering work to the transmission.

(c) The warm tires transfer heat to the cooler air and to some degree to the cooler road while no work is produced. No work is produced since there is no motion of the forces acting at the interface between the tire and road.

(d) There is minor amount of heat transfer between the tires and road. Presuming that the tires are hotter than the road, the heat transfer is from the tires to the road. There is no work exchange associated with the road since it cannot move.

(e) Heat is being added to the atmospheric air by the hotter components of the car. Work is being done on the air as it passes over and through the car.

2-19C (a) From the perspective of the contents, heat must be removed in order to reduce and maintain the content's temperature. Heat is also being added to the contents from the room air since the room air is hotter than the contents.

(b) Considering the system formed by the refrigerator box when the doors are closed, there are three interactions, electrical work and two heat transfers. There is a transfer of heat from the room air to the refrigerator through its walls. There is also a transfer of heat from the hot portions of the refrigerator (i.e., back of the compressor where condenser is placed) system to the room air. Finally, electrical work is being added to the refrigerator through the refrigeration system.

(c) Heat is transferred through the walls of the room from the warm room air to the cold winter air. Electrical work is being done on the room through the electrical wiring leading into the room.

2-20C It is a work interaction.

2-21C It is a work interaction since the electrons are crossing the system boundary, thus doing electrical work.

2-22C It is a heat interaction since it is due to the temperature difference between the sun and the room.

2-23C This is neither a heat nor a work interaction since no energy is crossing the system boundary. This is simply the conversion of one form of internal energy (chemical energy) to another form (sensible energy).

2-24 The power produced by an electrical motor is to be expressed in different units.

Analysis Using appropriate conversion factors, we obtain

$$(a) \quad \dot{W} = (5 \text{ W}) \left(\frac{1 \text{ J/s}}{1 \text{ W}} \right) \left(\frac{1 \text{ N} \cdot \text{m}}{1 \text{ J}} \right) = \mathbf{5 \text{ N} \cdot \text{m/s}}$$

$$(b) \quad \dot{W} = (5 \text{ W}) \left(\frac{1 \text{ J/s}}{1 \text{ W}} \right) \left(\frac{1 \text{ N} \cdot \text{m}}{1 \text{ J}} \right) \left(\frac{1 \text{ kg} \cdot \text{m/s}^2}{1 \text{ N}} \right) = \mathbf{5 \text{ kg} \cdot \text{m}^2/\text{s}^3}$$

2-25E The power produced by a model aircraft engine is to be expressed in different units.

Analysis Using appropriate conversion factors, we obtain

$$(a) \quad \dot{W} = (10 \text{ W}) \left(\frac{1 \text{ Btu/s}}{1055.056 \text{ W}} \right) \left(\frac{778.169 \text{ lbf} \cdot \text{ft/s}}{1 \text{ Btu/s}} \right) = \mathbf{7.38 \text{ lbf} \cdot \text{ft/s}}$$

$$(b) \quad \dot{W} = (10 \text{ W}) \left(\frac{1 \text{ hp}}{745.7 \text{ W}} \right) = \mathbf{0.0134 \text{ hp}}$$

Mechanical Forms of Work

2-26C The work done is the same, but the power is different.

2-27E A construction crane lifting a concrete beam is considered. The amount of work is to be determined considering (a) the beam and (b) the crane as the system.

Analysis (a) The work is done on the beam and it is determined from

$$W = mg\Delta z = (3 \times 2000 \text{ lbm})(32.174 \text{ ft/s}^2) \left(\frac{1 \text{ lbf}}{32.174 \text{ lbm} \cdot \text{ft/s}^2} \right) (24 \text{ ft})$$

$$= \mathbf{144,000 \text{ lbf} \cdot \text{ft}}$$

$$= (144,000 \text{ lbf} \cdot \text{ft}) \left(\frac{1 \text{ Btu}}{778.169 \text{ lbf} \cdot \text{ft}} \right) = \mathbf{185 \text{ Btu}}$$

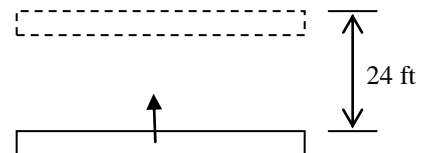

(b) Since the crane must produce the same amount of work as is required to lift the beam, the work done by the crane is

$$W = \mathbf{144,000 \text{ lbf} \cdot \text{ft} = 185 \text{ Btu}}$$

2-28E A man is pushing a cart with its contents up a ramp that is inclined at an angle of 10° from the horizontal. The work needed to move along this ramp is to be determined considering (a) the man and (b) the cart and its contents as the system.

Analysis (a) Considering the man as the system, letting l be the displacement along the ramp, and letting θ be the inclination angle of the ramp,

$$\begin{aligned} W &= Fl \sin \theta = (100 + 180 \text{ lbf})(100 \text{ ft})\sin(10) = \mathbf{4862 \text{ lbf} \cdot \text{ft}} \\ &= (4862 \text{ lbf} \cdot \text{ft}) \left(\frac{1 \text{ Btu}}{778.169 \text{ lbf} \cdot \text{ft}} \right) = \mathbf{6.248 \text{ Btu}} \end{aligned}$$

This is work that the man must do to raise the weight of the cart and contents, plus his own weight, a distance of $l \sin \theta$.

(b) Applying the same logic to the cart and its contents gives

$$\begin{aligned} W &= Fl \sin \theta = (100 \text{ lbf})(100 \text{ ft})\sin(10) = \mathbf{1736 \text{ lbf} \cdot \text{ft}} \\ &= (1736 \text{ lbf} \cdot \text{ft}) \left(\frac{1 \text{ Btu}}{778.169 \text{ lbf} \cdot \text{ft}} \right) = \mathbf{2.231 \text{ Btu}} \end{aligned}$$

2-29E The work required to compress a spring is to be determined.

Analysis Since there is no preload, $F = kx$. Substituting this into the work expression gives

$$\begin{aligned} W &= \int_1^2 F ds = \int_1^2 kx dx = k \int_1^2 x dx = \frac{k}{2} (x_2^2 - x_1^2) \\ &= \frac{200 \text{ lbf/in}}{2} [(1 \text{ in})^2 - 0^2] \left(\frac{1 \text{ ft}}{12 \text{ in}} \right) = \mathbf{8.33 \text{ lbf} \cdot \text{ft}} \\ &= (8.33 \text{ lbf} \cdot \text{ft}) \left(\frac{1 \text{ Btu}}{778.169 \text{ lbf} \cdot \text{ft}} \right) = \mathbf{0.0107 \text{ Btu}} \end{aligned}$$

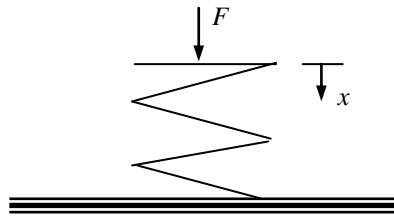

2-30 A car is accelerated from 10 to 60 km/h on an uphill road. The work needed to achieve this is to be determined.

Analysis The total work required is the sum of the changes in potential and kinetic energies,

$$W_a = \frac{1}{2} m (\mathbf{V}_2^2 - \mathbf{V}_1^2) = \frac{1}{2} (1300 \text{ kg}) \left(\left(\frac{60,000 \text{ m}}{3600 \text{ s}} \right)^2 - \left(\frac{10,000 \text{ m}}{3600 \text{ s}} \right)^2 \right) \left(\frac{1 \text{ kJ}}{1000 \text{ kg} \cdot \text{m}^2/\text{s}^2} \right) = 175.5 \text{ kJ}$$

and
$$W_g = mg(z_2 - z_1) = (1300 \text{ kg})(9.81 \text{ m/s}^2)(40 \text{ m}) \left(\frac{1 \text{ kJ}}{1000 \text{ kg} \cdot \text{m}^2/\text{s}^2} \right) = 510.0 \text{ kJ}$$

Thus,

$$W_{\text{total}} = W_a + W_g = 175.5 + 510.0 = \mathbf{686 \text{ kJ}}$$

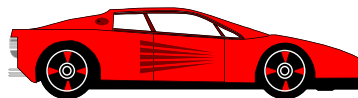

2-31E The engine of a car develops 450 hp at 3000 rpm. The torque transmitted through the shaft is to be determined.

Analysis The torque is determined from

$$T = \frac{\dot{W}_{sh}}{2\pi i} = \frac{450 \text{ hp}}{2\pi(3000/60)/s} \left(\frac{550 \text{ lbf} \cdot \text{ft/s}}{1 \text{ hp}} \right) = \mathbf{788 \text{ lbf} \cdot \text{ft}}$$

2-32E The work required to expand a soap bubble is to be determined.

Analysis Noting that there are two gas-liquid interfaces in a soap bubble, the surface tension work is determined from

$$\begin{aligned} W &= 2 \int_1^2 \sigma_s dA = \sigma(A_1 - A_2) = 2(0.005 \text{ lbf/ft}) \pi \left[(3/12 \text{ ft})^2 - (0.5/12 \text{ ft})^2 \right] \\ &= 0.001909 \text{ lbf} \cdot \text{ft} = (0.001909 \text{ lbf} \cdot \text{ft}) \left(\frac{1 \text{ Btu}}{778.2 \text{ lbf} \cdot \text{ft}} \right) = \mathbf{12.45 \times 10^{-6} \text{ Btu}} \end{aligned}$$

2-33 A linear spring is elongated by 20 cm from its rest position. The work done is to be determined.

Analysis The spring work can be determined from

$$W_{spring} = \frac{1}{2} k(x_2^2 - x_1^2) = \frac{1}{2} (70 \text{ kN/m})(0.2^2 - 0) \text{ m}^2 = 1.4 \text{ kN} \cdot \text{m} = \mathbf{1.4 \text{ kJ}}$$

2-34 A ski lift is operating steadily at 10 km/h. The power required to operate and also to accelerate this ski lift from rest to the operating speed are to be determined.

Assumptions **1** Air drag and friction are negligible. **2** The average mass of each loaded chair is 250 kg. **3** The mass of chairs is small relative to the mass of people, and thus the contribution of returning empty chairs to the motion is disregarded (this provides a safety factor).

Analysis The lift is 1000 m long and the chairs are spaced 20 m apart. Thus at any given time there are $1000/20 = 50$ chairs being lifted. Considering that the mass of each chair is 250 kg, the load of the lift at any given time is

$$\text{Load} = (50 \text{ chairs})(250 \text{ kg/chair}) = 12,500 \text{ kg}$$

Neglecting the work done on the system by the returning empty chairs, the work needed to raise this mass by 200 m is

$$W_g = mg(z_2 - z_1) = (12,500 \text{ kg})(9.81 \text{ m/s}^2)(200 \text{ m}) \left(\frac{1 \text{ kJ}}{1000 \text{ kg} \cdot \text{m}^2/\text{s}^2} \right) = 24,525 \text{ kJ}$$

At 10 km/h, it will take

$$\Delta t = \frac{\text{distance}}{\text{velocity}} = \frac{1 \text{ km}}{10 \text{ km/h}} = 0.1 \text{ h} = 360 \text{ s}$$

to do this work. Thus the power needed is

$$\dot{W}_g = \frac{W_g}{\Delta t} = \frac{24,525 \text{ kJ}}{360 \text{ s}} = \mathbf{68.1 \text{ kW}}$$

The velocity of the lift during steady operation, and the acceleration during start up are

$$V = (10 \text{ km/h}) \left(\frac{1 \text{ m/s}}{3.6 \text{ km/h}} \right) = 2.778 \text{ m/s}$$

$$a = \frac{\Delta V}{\Delta t} = \frac{2.778 \text{ m/s} - 0}{5 \text{ s}} = 0.556 \text{ m/s}^2$$

During acceleration, the power needed is

$$\dot{W}_a = \frac{1}{2} m(V_2^2 - V_1^2) / \Delta t = \frac{1}{2} (12,500 \text{ kg}) \left((2.778 \text{ m/s})^2 - 0 \right) \left(\frac{1 \text{ kJ/kg}}{1000 \text{ m}^2/\text{s}^2} \right) / (5 \text{ s}) = 9.6 \text{ kW}$$

Assuming the power applied is constant, the acceleration will also be constant and the vertical distance traveled during acceleration will be

$$h = \frac{1}{2} at^2 \sin \alpha = \frac{1}{2} at^2 \frac{200 \text{ m}}{1000 \text{ m}} = \frac{1}{2} (0.556 \text{ m/s}^2)(5 \text{ s})^2 (0.2) = 1.39 \text{ m}$$

and

$$\dot{W}_g = mg(z_2 - z_1) / \Delta t = (12,500 \text{ kg})(9.81 \text{ m/s}^2)(1.39 \text{ m}) \left(\frac{1 \text{ kJ/kg}}{1000 \text{ kg} \cdot \text{m}^2/\text{s}^2} \right) / (5 \text{ s}) = 34.1 \text{ kW}$$

Thus,

$$\dot{W}_{\text{total}} = \dot{W}_a + \dot{W}_g = 9.6 + 34.1 = \mathbf{43.7 \text{ kW}}$$

2-35 The engine of a car develops 75 kW of power. The acceleration time of this car from rest to 100 km/h on a level road is to be determined.

Analysis The work needed to accelerate a body is the change in its kinetic energy,

$$W_a = \frac{1}{2} m (V_2^2 - V_1^2) = \frac{1}{2} (1500 \text{ kg}) \left[\left(\frac{100,000 \text{ m}}{3600 \text{ s}} \right)^2 - 0 \right] \left(\frac{1 \text{ kJ}}{1000 \text{ kg} \cdot \text{m}^2/\text{s}^2} \right) = 578.7 \text{ kJ}$$

Thus the time required is

$$\Delta t = \frac{W_a}{\dot{W}_a} = \frac{578.7 \text{ kJ}}{75 \text{ kJ/s}} = 7.72 \text{ s}$$

This answer is not realistic because part of the power will be used against the air drag, friction, and rolling resistance.

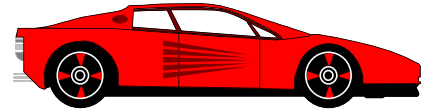

2-36 A car is to climb a hill in 12 s. The power needed is to be determined for three different cases.

Assumptions Air drag, friction, and rolling resistance are negligible.

Analysis The total power required for each case is the sum of the rates of changes in potential and kinetic energies. That is,

$$\dot{W}_{\text{total}} = \dot{W}_a + \dot{W}_g$$

(a) $\dot{W}_a = 0$ since the velocity is constant. Also, the vertical rise is $h = (100 \text{ m})(\sin 30^\circ) = 50 \text{ m}$. Thus,

$$\dot{W}_g = mg(z_2 - z_1) / \Delta t = (1150 \text{ kg})(9.81 \text{ m/s}^2)(50 \text{ m}) \left(\frac{1 \text{ kJ}}{1000 \text{ kg} \cdot \text{m}^2/\text{s}^2} \right) / (12 \text{ s}) = 47.0 \text{ kW}$$

and $\dot{W}_{\text{total}} = \dot{W}_a + \dot{W}_g = 0 + 47.0 = \mathbf{47.0 \text{ kW}}$

(b) The power needed to accelerate is

$$\dot{W}_a = \frac{1}{2} m (V_2^2 - V_1^2) / \Delta t = \frac{1}{2} (1150 \text{ kg}) \left[(30 \text{ m/s})^2 - 0 \right] \left(\frac{1 \text{ kJ}}{1000 \text{ kg} \cdot \text{m}^2/\text{s}^2} \right) / (12 \text{ s}) = 43.1 \text{ kW}$$

and $\dot{W}_{\text{total}} = \dot{W}_a + \dot{W}_g = 47.0 + 43.1 = \mathbf{90.1 \text{ kW}}$

(c) The power needed to decelerate is

$$\dot{W}_a = \frac{1}{2} m (V_2^2 - V_1^2) / \Delta t = \frac{1}{2} (1150 \text{ kg}) \left[(5 \text{ m/s})^2 - (35 \text{ m/s})^2 \right] \left(\frac{1 \text{ kJ}}{1000 \text{ kg} \cdot \text{m}^2/\text{s}^2} \right) / (12 \text{ s}) = -57.5 \text{ kW}$$

and $\dot{W}_{\text{total}} = \dot{W}_a + \dot{W}_g = -57.5 + 47.1 = \mathbf{-10.5 \text{ kW}}$ (braking power)

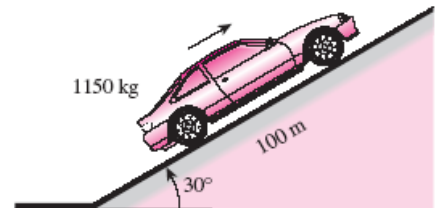

The First Law of Thermodynamics

2-37C Energy can be transferred to or from a control volume as heat, various forms of work, and by mass transport.

2-38C Warmer. Because energy is added to the room air in the form of electrical work.

2-39 Water is heated in a pan on top of a range while being stirred. The energy of the water at the end of the process is to be determined.

Assumptions The pan is stationary and thus the changes in kinetic and potential energies are negligible.

Analysis We take the water in the pan as our system. This is a closed system since no mass enters or leaves. Applying the energy balance on this system gives

$$\underbrace{E_{\text{in}} - E_{\text{out}}}_{\substack{\text{Net energy transfer} \\ \text{by heat, work, and mass}}} = \underbrace{\Delta E_{\text{system}}}_{\substack{\text{Change in internal, kinetic,} \\ \text{potential, etc. energies}}}$$

$$Q_{\text{in}} + W_{\text{sh,in}} - Q_{\text{out}} = \Delta U = U_2 - U_1$$

$$30 \text{ kJ} + 0.5 \text{ kJ} - 5 \text{ kJ} = U_2 - 10 \text{ kJ}$$

$$U_2 = \mathbf{35.5 \text{ kJ}}$$

Therefore, the final internal energy of the system is 35.5 kJ.

2-40E Water is heated in a cylinder on top of a range. The change in the energy of the water during this process is to be determined.

Assumptions The pan is stationary and thus the changes in kinetic and potential energies are negligible.

Analysis We take the water in the cylinder as the system. This is a closed system since no mass enters or leaves. Applying the energy balance on this system gives

$$\underbrace{E_{\text{in}} - E_{\text{out}}}_{\substack{\text{Net energy transfer} \\ \text{by heat, work, and mass}}} = \underbrace{\Delta E_{\text{system}}}_{\substack{\text{Change in internal, kinetic,} \\ \text{potential, etc. energies}}}$$

$$Q_{\text{in}} - W_{\text{out}} - Q_{\text{out}} = \Delta U = U_2 - U_1$$

$$65 \text{ Btu} - 5 \text{ Btu} - 8 \text{ Btu} = \Delta U$$

$$\Delta U = U_2 - U_1 = \mathbf{52 \text{ Btu}}$$

Therefore, the energy content of the system increases by 52 Btu during this process.

2-41E The heat loss from a house is to be made up by heat gain from people, lights, appliances, and resistance heaters. For a specified rate of heat loss, the required rated power of resistance heaters is to be determined.

Assumptions 1 The house is well-sealed, so no air enters or leaves the house. **2** All the lights and appliances are kept on. **3** The house temperature remains constant.

Analysis Taking the house as the system, the energy balance can be written as

$$\underbrace{\dot{E}_{\text{in}} - \dot{E}_{\text{out}}}_{\text{Rate of net energy transfer by heat, work, and mass}} = \underbrace{dE_{\text{system}}/dt}_{\text{Rate of change in internal, kinetic, potential, etc. energies}} \stackrel{\text{steady}}{\approx} 0 \rightarrow \dot{E}_{\text{in}} = \dot{E}_{\text{out}}$$

where $\dot{E}_{\text{out}} = \dot{Q}_{\text{out}} = 60,000 \text{ Btu/h}$ and

$$\dot{E}_{\text{in}} = \dot{E}_{\text{people}} + \dot{E}_{\text{lights}} + \dot{E}_{\text{appliance}} + \dot{E}_{\text{heater}} = 6000 \text{ Btu/h} + \dot{E}_{\text{heater}}$$

Substituting, the required power rating of the heaters becomes

$$\dot{E}_{\text{heater}} = 60,000 - 6000 = 54,000 \text{ Btu/h} \left(\frac{1 \text{ kW}}{3412 \text{ Btu/h}} \right) = \mathbf{15.8 \text{ kW}}$$

Discussion When the energy gain of the house equals the energy loss, the temperature of the house remains constant. But when the energy supplied drops below the heat loss, the house temperature starts dropping.

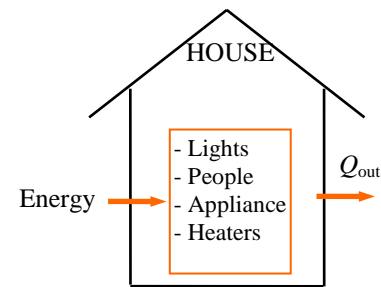

2-42E A water pump increases water pressure. The power input is to be determined.

Analysis The power input is determined from

$$\begin{aligned} \dot{W} &= \dot{V}(P_2 - P_1) \\ &= (0.8 \text{ ft}^3/\text{s})(70 - 15) \text{ psia} \left(\frac{1 \text{ Btu}}{5.404 \text{ psia} \cdot \text{ft}^3} \right) \left(\frac{1 \text{ hp}}{0.7068 \text{ Btu/s}} \right) \\ &= \mathbf{11.5 \text{ hp}} \end{aligned}$$

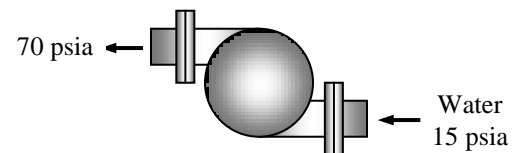

The water temperature at the inlet does not have any significant effect on the required power.

2-43 A water pump is claimed to raise water to a specified elevation at a specified rate while consuming electric power at a specified rate. The validity of this claim is to be investigated.

Assumptions 1 The water pump operates steadily. **2** Both the lake and the pool are open to the atmosphere, and the flow velocities in them are negligible.

Properties We take the density of water to be $\rho = 1000 \text{ kg/m}^3 = 1 \text{ kg/L}$.

Analysis For a control volume that encloses the pump-motor unit, the energy balance can be written as

$$\underbrace{\dot{E}_{in} - \dot{E}_{out}}_{\text{Rate of net energy transfer by heat, work, and mass}} = \underbrace{\frac{dE_{\text{system}}}{dt}}_{\text{Rate of change in internal, kinetic, potential, etc. energies}} \stackrel{\text{steady}}{\neq} 0 = 0$$

$$\dot{E}_{in} = \dot{E}_{out}$$

$$\dot{W}_{in} + \dot{m}pe_1 = \dot{m}pe_2 \rightarrow \dot{W}_{in} = \dot{m}\Delta pe = \dot{m}g(z_2 - z_1)$$

since the changes in kinetic and flow energies of water are negligible. Also,

$$\dot{m} = \rho\dot{V} = (1 \text{ kg/L})(50 \text{ L/s}) = 50 \text{ kg/s}$$

Substituting, the minimum power input required is determined to be

$$\dot{W}_{in} = \dot{m}g(z_2 - z_1) = (50 \text{ kg/s})(9.81 \text{ m/s}^2)(30 \text{ m}) \left(\frac{1 \text{ kJ/kg}}{1000 \text{ m}^2/\text{s}^2} \right) = 14.7 \text{ kJ/s} = \mathbf{14.7 \text{ kW}}$$

which is much greater than 2 kW. Therefore, the claim is **false**.

Discussion The conservation of energy principle requires the energy to be conserved as it is converted from one form to another, and it does not allow any energy to be created or destroyed during a process. In reality, the power required will be considerably higher than 14.7 kW because of the losses associated with the conversion of electrical-to-mechanical shaft and mechanical shaft-to-potential energy of water.

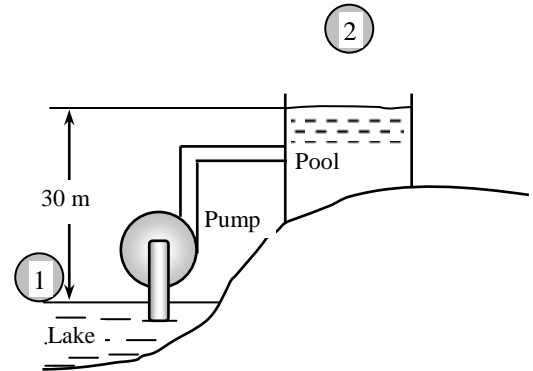

2-44 A classroom is to be air-conditioned using window air-conditioning units. The cooling load is due to people, lights, and heat transfer through the walls and the windows. The number of 5-kW window air conditioning units required is to be determined.

Assumptions There are no heat dissipating equipment (such as computers, TVs, or ranges) in the room.

Analysis The total cooling load of the room is determined from

$$\dot{Q}_{\text{cooling}} = \dot{Q}_{\text{lights}} + \dot{Q}_{\text{people}} + \dot{Q}_{\text{heat gain}}$$

where

$$\dot{Q}_{\text{lights}} = 10 \times 100 \text{ W} = 1 \text{ kW}$$

$$\dot{Q}_{\text{people}} = 40 \times 360 \text{ kJ/h} = 4 \text{ kW}$$

$$\dot{Q}_{\text{heat gain}} = 15,000 \text{ kJ/h} = 4.17 \text{ kW}$$

Substituting, $\dot{Q}_{\text{cooling}} = 1 + 4 + 4.17 = 9.17 \text{ kW}$

Thus the number of air-conditioning units required is

$$\frac{9.17 \text{ kW}}{5 \text{ kW/unit}} = 1.83 \rightarrow \mathbf{2 \text{ units}}$$

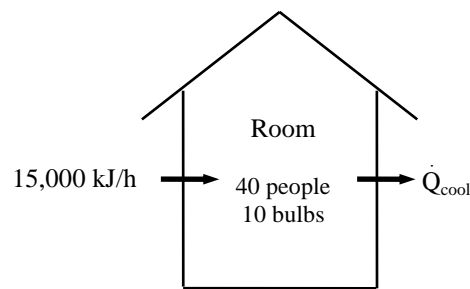

2-45 The classrooms and faculty offices of a university campus are not occupied an average of 4 hours a day, but the lights are kept on. The amounts of electricity and money the campus will save per year if the lights are turned off during unoccupied periods are to be determined.

Analysis The total electric power consumed by the lights in the classrooms and faculty offices is

$$\dot{E}_{\text{lighting, classroom}} = (\text{Power consumed per lamp}) \times (\text{No. of lamps}) = (200 \times 12 \times 110 \text{ W}) = 264,000 = 264 \text{ kW}$$

$$\dot{E}_{\text{lighting, offices}} = (\text{Power consumed per lamp}) \times (\text{No. of lamps}) = (400 \times 6 \times 110 \text{ W}) = 264,000 = 264 \text{ kW}$$

$$\dot{E}_{\text{lighting, total}} = \dot{E}_{\text{lighting, classroom}} + \dot{E}_{\text{lighting, offices}} = 264 + 264 = 528 \text{ kW}$$

Noting that the campus is open 240 days a year, the total number of unoccupied work hours per year is

$$\text{Unoccupied hours} = (4 \text{ hours/day})(240 \text{ days/year}) = 960 \text{ h/yr}$$

Then the amount of electrical energy consumed per year during unoccupied work period and its cost are

$$\text{Energy savings} = (\dot{E}_{\text{lighting, total}})(\text{Unoccupied hours}) = (528 \text{ kW})(960 \text{ h/yr}) = 506,880 \text{ kWh}$$

$$\text{Cost savings} = (\text{Energy savings})(\text{Unit cost of energy}) = (506,880 \text{ kWh/yr})(\$0.11/\text{kWh}) = \mathbf{\$55,757/\text{yr}}$$

Discussion Note that simple conservation measures can result in significant energy and cost savings.

2-46 An industrial facility is to replace its 40-W standard fluorescent lamps by their 35-W high efficiency counterparts. The amount of energy and money that will be saved a year as well as the simple payback period are to be determined.

Analysis The reduction in the total electric power consumed by the lighting as a result of switching to the high efficiency fluorescent is

$$\begin{aligned} \text{Wattage reduction} &= (\text{Wattage reduction per lamp})(\text{Number of lamps}) \\ &= (40 - 34 \text{ W/lamp})(700 \text{ lamps}) \\ &= 4200 \text{ W} \end{aligned}$$

Then using the relations given earlier, the energy and cost savings associated with the replacement of the high efficiency fluorescent lamps are determined to be

$$\begin{aligned} \text{Energy Savings} &= (\text{Total wattage reduction})(\text{Ballast factor})(\text{Operating hours}) \\ &= (4.2 \text{ kW})(1.1)(2800 \text{ h/year}) \\ &= \mathbf{12,936 \text{ kWh/year}} \end{aligned}$$

$$\begin{aligned} \text{Cost Savings} &= (\text{Energy savings})(\text{Unit electricity cost}) \\ &= (12,936 \text{ kWh/year})(\$0.105/\text{kWh}) \\ &= \mathbf{\$1358/\text{year}} \end{aligned}$$

The implementation cost of this measure is simply the extra cost of the energy efficient fluorescent bulbs relative to standard ones, and is determined to be

$$\begin{aligned} \text{Implementation Cost} &= (\text{Cost difference of lamps})(\text{Number of lamps}) \\ &= [(\$2.26 - \$1.77)/\text{lamp}](700 \text{ lamps}) \\ &= \$343 \end{aligned}$$

This gives a simple payback period of

$$\text{Simple payback period} = \frac{\text{Implementation cost}}{\text{Annual cost savings}} = \frac{\$343}{\$1358/\text{year}} = \mathbf{0.25 \text{ year}} \quad (3.0 \text{ months})$$

Discussion Note that if all the lamps were burned out today and are replaced by high-efficiency lamps instead of the conventional ones, the savings from electricity cost would pay for the cost differential in about 4 months. The electricity saved will also help the environment by reducing the amount of CO₂, CO, NO_x, etc. associated with the generation of electricity in a power plant.



2-47 A room contains a light bulb, a TV set, a refrigerator, and an iron. The rate of increase of the energy content of the room when all of these electric devices are on is to be determined.

Assumptions 1 The room is well sealed, and heat loss from the room is negligible. **2** All the appliances are kept on.

Analysis Taking the room as the system, the rate form of the energy balance can be written as

$$\underbrace{\dot{E}_{in} - \dot{E}_{out}}_{\text{Rate of net energy transfer by heat, work, and mass}} = \underbrace{dE_{\text{system}} / dt}_{\text{Rate of change in internal, kinetic, potential, etc. energies}} \rightarrow dE_{\text{room}} / dt = \dot{E}_{in}$$

since no energy is leaving the room in any form, and thus $\dot{E}_{out} = 0$. Also,

$$\begin{aligned} \dot{E}_{in} &= \dot{E}_{\text{lights}} + \dot{E}_{\text{TV}} + \dot{E}_{\text{refrig}} + \dot{E}_{\text{iron}} \\ &= 40 + 110 + 300 + 1200 \text{ W} \\ &= 1650 \text{ W} \end{aligned}$$

Substituting, the rate of increase in the energy content of the room becomes

$$dE_{\text{room}} / dt = \dot{E}_{in} = \mathbf{1650 \text{ W}}$$

Discussion Note that some appliances such as refrigerators and irons operate intermittently, switching on and off as controlled by a thermostat. Therefore, the rate of energy transfer to the room, in general, will be less.

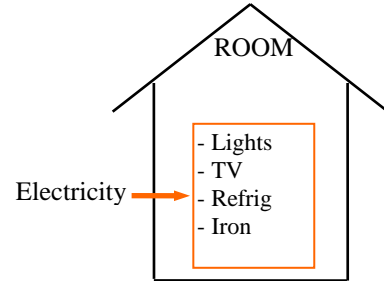

2-48E A fan accelerates air to a specified velocity in a square duct. The minimum electric power that must be supplied to the fan motor is to be determined.

Assumptions 1 The fan operates steadily. **2** There are no conversion losses.

Properties The density of air is given to be $\rho = 0.075 \text{ lbm/ft}^3$.

Analysis A fan motor converts electrical energy to mechanical shaft energy, and the fan transmits the mechanical energy of the shaft (shaft power) to mechanical energy of air (kinetic energy). For a control volume that encloses the fan-motor unit, the energy balance can be written as

$$\underbrace{\dot{E}_{in} - \dot{E}_{out}}_{\text{Rate of net energy transfer by heat, work, and mass}} = \underbrace{dE_{\text{system}} / dt}_{\text{Rate of change in internal, kinetic, potential, etc. energies}} \stackrel{\text{steady}}{=} 0 \rightarrow \dot{E}_{in} = \dot{E}_{out}$$

$$\dot{W}_{\text{elect, in}} = \dot{m}_{\text{air}} \text{ke}_{\text{out}} = \dot{m}_{\text{air}} \frac{V_{\text{out}}^2}{2}$$

where

$$\dot{m}_{\text{air}} = \rho VA = (0.075 \text{ lbm/ft}^3)(3 \times 3 \text{ ft}^2)(22 \text{ ft/s}) = 14.85 \text{ lbm/s}$$

Substituting, the minimum power input required is determined to be

$$\dot{W}_{in} = \dot{m}_{\text{air}} \frac{V_{\text{out}}^2}{2} = (14.85 \text{ lbm/s}) \frac{(22 \text{ ft/s})^2}{2} \left(\frac{1 \text{ Btu/lbm}}{25,037 \text{ ft}^2/\text{s}^2} \right) = 0.1435 \text{ Btu/s} = \mathbf{151 \text{ W}}$$

since $1 \text{ Btu} = 1.055 \text{ kJ}$ and $1 \text{ kJ/s} = 1000 \text{ W}$.

Discussion The conservation of energy principle requires the energy to be conserved as it is converted from one form to another, and it does not allow any energy to be created or destroyed during a process. In reality, the power required will be considerably higher because of the losses associated with the conversion of electrical-to-mechanical shaft and mechanical shaft-to-kinetic energy of air.

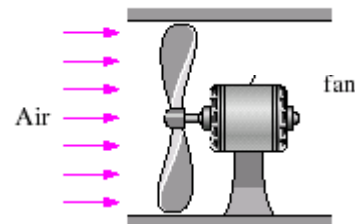

2-49 The fan of a central heating system circulates air through the ducts. For a specified pressure rise, the highest possible average flow velocity is to be determined.

Assumptions 1 The fan operates steadily. **2** The changes in kinetic and potential energies across the fan are negligible.

Analysis For a control volume that encloses the fan unit, the energy balance can be written as

$$\underbrace{\dot{E}_{in} - \dot{E}_{out}}_{\text{Rate of net energy transfer by heat, work, and mass}} = \underbrace{dE_{\text{system}}/dt}_{\text{Rate of change in internal, kinetic, potential, etc. energies}} \stackrel{\text{steady}}{\neq} 0 \rightarrow \dot{E}_{in} = \dot{E}_{out}$$

$$\dot{W}_{in} + \dot{m}(Pv)_1 = \dot{m}(Pv)_2 \rightarrow \dot{W}_{in} = \dot{m}(P_2 - P_1)v = \dot{V} \Delta P$$

since $\dot{m} = \dot{V}/v$ and the changes in kinetic and potential energies of gasoline are negligible, Solving for volume flow rate and substituting, the maximum flow rate and velocity are determined to be

$$\dot{V}_{\max} = \frac{\dot{W}_{in}}{\Delta P} = \frac{60 \text{ J/s}}{50 \text{ Pa}} \left(\frac{1 \text{ Pa} \cdot \text{m}^3}{1 \text{ J}} \right) = 1.2 \text{ m}^3/\text{s}$$

$$V_{\max} = \frac{\dot{V}_{\max}}{A_c} = \frac{\dot{V}_{\max}}{\pi D^2 / 4} = \frac{1.2 \text{ m}^3/\text{s}}{\pi (0.30 \text{ m})^2 / 4} = \mathbf{17.0 \text{ m/s}}$$

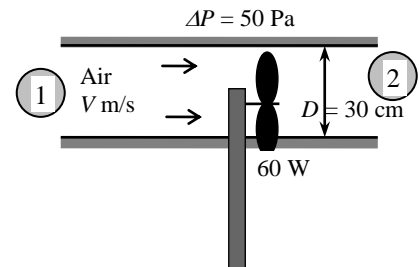

Discussion The conservation of energy principle requires the energy to be conserved as it is converted from one form to another, and it does not allow any energy to be created or destroyed during a process. In reality, the velocity will be less because of the losses associated with the conversion of electrical-to-mechanical shaft and mechanical shaft-to-flow energy.



2-50 A gasoline pump raises the pressure to a specified value while consuming electric power at a specified rate. The maximum volume flow rate of gasoline is to be determined.

Assumptions 1 The gasoline pump operates steadily. **2** The changes in kinetic and potential energies across the pump are negligible.

Analysis For a control volume that encloses the pump-motor unit, the energy balance can be written as

$$\underbrace{\dot{E}_{in} - \dot{E}_{out}}_{\text{Rate of net energy transfer by heat, work, and mass}} = \underbrace{dE_{\text{system}}/dt}_{\text{Rate of change in internal, kinetic, potential, etc. energies}} \stackrel{\text{steady}}{\neq} 0 \rightarrow \dot{E}_{in} = \dot{E}_{out}$$

$$\dot{W}_{in} + \dot{m}(Pv)_1 = \dot{m}(Pv)_2 \rightarrow \dot{W}_{in} = \dot{m}(P_2 - P_1)v = \dot{V} \Delta P$$

since $\dot{m} = \dot{V}/v$ and the changes in kinetic and potential energies of gasoline are negligible, Solving for volume flow rate and substituting, the maximum flow rate is determined to be

$$\dot{V}_{\max} = \frac{\dot{W}_{in}}{\Delta P} = \frac{3.8 \text{ kJ/s}}{7 \text{ kPa}} \left(\frac{1 \text{ kPa} \cdot \text{m}^3}{1 \text{ kJ}} \right) = \mathbf{0.543 \text{ m}^3/\text{s}}$$

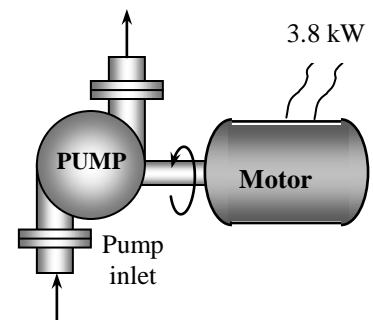

Discussion The conservation of energy principle requires the energy to be conserved as it is converted from one form to another, and it does not allow any energy to be created or destroyed during a process. In reality, the volume flow rate will be less because of the losses associated with the conversion of electrical-to-mechanical shaft and mechanical shaft-to-flow energy.

2-51 An inclined escalator is to move a certain number of people upstairs at a constant velocity. The minimum power required to drive this escalator is to be determined.

Assumptions **1** Air drag and friction are negligible. **2** The average mass of each person is 75 kg. **3** The escalator operates steadily, with no acceleration or braking. **4** The mass of escalator itself is negligible.

Analysis At design conditions, the total mass moved by the escalator at any given time is

$$\text{Mass} = (50 \text{ persons})(75 \text{ kg/person}) = 3750 \text{ kg}$$

The vertical component of escalator velocity is

$$V_{\text{vert}} = V \sin 45^\circ = (0.6 \text{ m/s})\sin 45^\circ$$

Under stated assumptions, the power supplied is used to increase the potential energy of people. Taking the people on elevator as the closed system, the energy balance in the rate form can be written as

$$\underbrace{\dot{E}_{\text{in}} - \dot{E}_{\text{out}}}_{\substack{\text{Rate of net energy transfer} \\ \text{by heat, work, and mass}}} = \underbrace{dE_{\text{system}}/dt}_{\substack{\text{Rate of change in internal, kinetic,} \\ \text{potential, etc. energies}}} = 0 \quad \rightarrow \quad \dot{E}_{\text{in}} = dE_{\text{sys}}/dt \cong \frac{\Delta E_{\text{sys}}}{\Delta t}$$

$$\dot{W}_{\text{in}} = \frac{\Delta PE}{\Delta t} = \frac{mg\Delta z}{\Delta t} = mgV_{\text{vert}}$$

That is, under stated assumptions, the power input to the escalator must be equal to the rate of increase of the potential energy of people. Substituting, the required power input becomes

$$\dot{W}_{\text{in}} = mgV_{\text{vert}} = (3750 \text{ kg})(9.81 \text{ m/s}^2)(0.6 \text{ m/s})\sin 45^\circ \left(\frac{1 \text{ kJ/kg}}{1000 \text{ m}^2/\text{s}^2} \right) = 12.5 \text{ kJ/s} = \mathbf{15.6 \text{ kW}}$$

When the escalator velocity is doubled to $V = 1.2 \text{ m/s}$, the power needed to drive the escalator becomes

$$\dot{W}_{\text{in}} = mgV_{\text{vert}} = (3750 \text{ kg})(9.81 \text{ m/s}^2)(1.2 \text{ m/s})\sin 45^\circ \left(\frac{1 \text{ kJ/kg}}{1000 \text{ m}^2/\text{s}^2} \right) = 25.0 \text{ kJ/s} = \mathbf{31.2 \text{ kW}}$$

Discussion Note that the power needed to drive an escalator is proportional to the escalator velocity.

2-52 A car cruising at a constant speed to accelerate to a specified speed within a specified time. The additional power needed to achieve this acceleration is to be determined.

Assumptions 1 The additional air drag, friction, and rolling resistance are not considered. **2** The road is a level road.

Analysis We consider the entire car as the system, except that let's assume the power is supplied to the engine externally for simplicity (rather than internally by the combustion of a fuel and the associated energy conversion processes). The energy balance for the entire mass of the car can be written in the rate form as

$$\underbrace{\dot{E}_{\text{in}} - \dot{E}_{\text{out}}}_{\substack{\text{Rate of net energy transfer} \\ \text{by heat, work, and mass}}} = \underbrace{dE_{\text{system}}/dt}_{\substack{\text{Rate of change in internal, kinetic,} \\ \text{potential, etc. energies}}} = 0 \rightarrow \dot{E}_{\text{in}} = dE_{\text{sys}}/dt \cong \frac{\Delta E_{\text{sys}}}{\Delta t}$$

$$\dot{W}_{\text{in}} = \frac{\Delta KE}{\Delta t} = \frac{m(V_2^2 - V_1^2)/2}{\Delta t}$$

since we are considering the change in the energy content of the car due to a change in its kinetic energy (acceleration). Substituting, the required additional power input to achieve the indicated acceleration becomes



$$\dot{W}_{\text{in}} = m \frac{V_2^2 - V_1^2}{2\Delta t} = (1400 \text{ kg}) \frac{(110/3.6 \text{ m/s})^2 - (70/3.6 \text{ m/s})^2}{2(5 \text{ s})} \left(\frac{1 \text{ kJ/kg}}{1000 \text{ m}^2/\text{s}^2} \right) = 77.8 \text{ kJ/s} = \mathbf{77.8 \text{ kW}}$$

since $1 \text{ m/s} = 3.6 \text{ km/h}$. If the total mass of the car were 700 kg only, the power needed would be

$$\dot{W}_{\text{in}} = m \frac{V_2^2 - V_1^2}{2\Delta t} = (700 \text{ kg}) \frac{(110/3.6 \text{ m/s})^2 - (70/3.6 \text{ m/s})^2}{2(5 \text{ s})} \left(\frac{1 \text{ kJ/kg}}{1000 \text{ m}^2/\text{s}^2} \right) = \mathbf{38.9 \text{ kW}}$$

Discussion Note that the power needed to accelerate a car is inversely proportional to the acceleration time. Therefore, the short acceleration times are indicative of powerful engines.

Energy Conversion Efficiencies

2-53C The *combined pump-motor efficiency* of a pump/motor system is defined as the ratio of the increase in the mechanical energy of the fluid to the electrical power consumption of the motor,

$$\eta_{\text{pump-motor}} = \eta_{\text{pump}} \eta_{\text{motor}} = \frac{\dot{E}_{\text{mech,out}} - \dot{E}_{\text{mech,in}}}{\dot{W}_{\text{elect,in}}} = \frac{\Delta \dot{E}_{\text{mech,fluid}}}{\dot{W}_{\text{elect,in}}} = \frac{\dot{W}_{\text{pump}}}{\dot{W}_{\text{elect,in}}}$$

The combined pump-motor efficiency cannot be greater than either of the pump or motor efficiency since both pump and motor efficiencies are less than 1, and the product of two numbers that are less than one is less than either of the numbers.

2-54C The turbine efficiency, generator efficiency, and *combined turbine-generator efficiency* are defined as follows:

$$\eta_{\text{turbine}} = \frac{\text{Mechanical energy output}}{\text{Mechanical energy extracted from the fluid}} = \frac{\dot{W}_{\text{shaft,out}}}{|\Delta \dot{E}_{\text{mech,fluid}}|}$$

$$\eta_{\text{generator}} = \frac{\text{Electrical power output}}{\text{Mechanical power input}} = \frac{\dot{W}_{\text{elect,out}}}{\dot{W}_{\text{shaft,in}}}$$

$$\eta_{\text{turbine-gen}} = \eta_{\text{turbine}} \eta_{\text{generator}} = \frac{\dot{W}_{\text{elect,out}}}{\dot{E}_{\text{mech,in}} - \dot{E}_{\text{mech,out}}} = \frac{\dot{W}_{\text{elect,out}}}{|\Delta \dot{E}_{\text{mech,fluid}}|}$$

2-55C No, the combined pump-motor efficiency cannot be greater than either of the pump efficiency or the motor efficiency. This is because $\eta_{\text{pump-motor}} = \eta_{\text{pump}}\eta_{\text{motor}}$, and both η_{pump} and η_{motor} are less than one, and a number gets smaller when multiplied by a number smaller than one.

2-56 A hooded electric open burner and a gas burner are considered. The amount of the electrical energy used directly for cooking and the cost of energy per “utilized” kWh are to be determined.

Analysis The efficiency of the electric heater is given to be 73 percent. Therefore, a burner that consumes 3-kW of electrical energy will supply

$$\eta_{\text{gas}} = 38\%$$

$$\eta_{\text{electric}} = 73\%$$

$$\dot{Q}_{\text{utilized}} = (\text{Energy input}) \times (\text{Efficiency}) = (2.4 \text{ kW})(0.73) = \mathbf{1.75 \text{ kW}}$$

of useful energy. The unit cost of utilized energy is inversely proportional to the efficiency, and is determined from

$$\text{Cost of utilized energy} = \frac{\text{Cost of energy input}}{\text{Efficiency}} = \frac{\$0.10/\text{kWh}}{0.73} = \mathbf{\$0.137/\text{kWh}}$$

Noting that the efficiency of a gas burner is 38 percent, the energy input to a gas burner that supplies utilized energy at the same rate (1.75 kW) is

$$\dot{Q}_{\text{input,gas}} = \frac{\dot{Q}_{\text{utilized}}}{\text{Efficiency}} = \frac{1.75 \text{ kW}}{0.38} = \mathbf{4.61 \text{ kW}} \quad (= 15,700 \text{ Btu/h})$$

since 1 kW = 3412 Btu/h. Therefore, a gas burner should have a rating of at least 15,700 Btu/h to perform as well as the electric unit. Noting that 1 therm = 29.3 kWh, the unit cost of utilized energy in the case of gas burner is determined the same way to be

$$\text{Cost of utilized energy} = \frac{\text{Cost of energy input}}{\text{Efficiency}} = \frac{\$1.20/(29.3 \text{ kWh})}{0.38} = \mathbf{\$0.108/\text{kWh}}$$

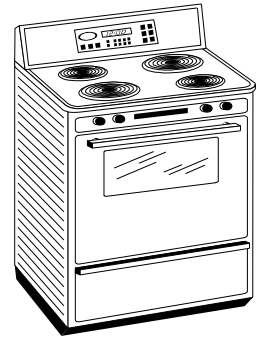

2-57 A worn out standard motor is to be replaced by a high efficiency one. The amount of electrical energy and money savings as a result of installing the high efficiency motor instead of the standard one as well as the simple payback period are to be determined.

Assumptions The load factor of the motor remains constant at 0.75.

Analysis The electric power drawn by each motor and their difference can be expressed as

$$\begin{aligned}\dot{W}_{\text{electric in, standard}} &= \dot{W}_{\text{shaft}} / \eta_{\text{standard}} = (\text{Power rating})(\text{Load factor}) / \eta_{\text{standard}} \\ \dot{W}_{\text{electric in, efficient}} &= \dot{W}_{\text{shaft}} / \eta_{\text{efficient}} = (\text{Power rating})(\text{Load factor}) / \eta_{\text{efficient}} \\ \text{Power savings} &= \dot{W}_{\text{electric in, standard}} - \dot{W}_{\text{electric in, efficient}} \\ &= (\text{Power rating})(\text{Load factor})[1 / \eta_{\text{standard}} - 1 / \eta_{\text{efficient}}]\end{aligned}$$

where η_{standard} is the efficiency of the standard motor, and $\eta_{\text{efficient}}$ is the efficiency of the comparable high efficiency motor. Then the annual energy and cost savings associated with the installation of the high efficiency motor are determined to be

$$\begin{aligned}\text{Energy Savings} &= (\text{Power savings})(\text{Operating Hours}) \\ &= (\text{Power Rating})(\text{Operating Hours})(\text{Load Factor})(1/\eta_{\text{standard}} - 1/\eta_{\text{efficient}}) \\ &= (75 \text{ hp})(0.746 \text{ kW/hp})(4,368 \text{ hours/year})(0.75)(1/0.91 - 1/0.954) \\ &= \mathbf{9,290 \text{ kWh/year}}\end{aligned}$$

$$\begin{aligned}\text{Cost Savings} &= (\text{Energy savings})(\text{Unit cost of energy}) \\ &= (9,290 \text{ kWh/year})(\$0.12/\text{kWh}) \\ &= \mathbf{\$1114/\text{year}}\end{aligned}$$

The implementation cost of this measure consists of the excess cost the high efficiency motor over the standard one. That is,

$$\text{Implementation Cost} = \text{Cost differential} = \$5,520 - \$5,449 = \$71$$

This gives a simple payback period of

$$\text{Simple payback period} = \frac{\text{Implementation cost}}{\text{Annual cost savings}} = \frac{\$71}{\$1114/\text{year}} = \mathbf{0.0637 \text{ year}} \text{ (or 0.76 month)}$$

Therefore, the high-efficiency motor will pay for its cost differential in less than one month.

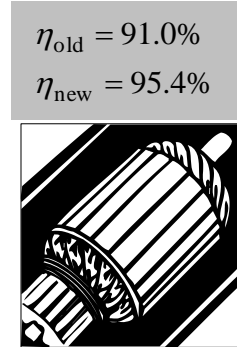

2-58 An electric motor with a specified efficiency operates in a room. The rate at which the motor dissipates heat to the room it is in when operating at full load and if this heat dissipation is adequate to heat the room in winter are to be determined.

Assumptions The motor operates at full load.

Analysis The motor efficiency represents the fraction of electrical energy consumed by the motor that is converted to mechanical work. The remaining part of electrical energy is converted to thermal energy and is dissipated as heat.

$$\dot{Q}_{\text{dissipated}} = (1 - \eta_{\text{motor}})\dot{W}_{\text{in, electric}} = (1 - 0.88)(20 \text{ kW}) = \mathbf{2.4 \text{ kW}}$$

which is larger than the rating of the heater. Therefore, the heat dissipated by the motor alone is sufficient to heat the room in winter, and there is no need to turn the heater on.

Discussion Note that the heat generated by electric motors is significant, and it should be considered in the determination of heating and cooling loads.

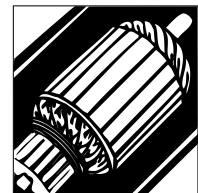

2-59E The combustion efficiency of a furnace is raised from 0.7 to 0.8 by tuning it up. The annual energy and cost savings as a result of tuning up the boiler are to be determined.

Assumptions The boiler operates at full load while operating.

Analysis The heat output of boiler is related to the fuel energy input to the boiler by

$$\text{Boiler output} = (\text{Boiler input})(\text{Combustion efficiency})$$

or
$$\dot{Q}_{\text{out}} = \dot{Q}_{\text{in}} \eta_{\text{furnace}}$$

The current rate of heat input to the boiler is given to be $\dot{Q}_{\text{in,current}} = 5.5 \times 10^6 \text{ Btu/h}$.

Then the rate of useful heat output of the boiler becomes

$$\dot{Q}_{\text{out}} = (\dot{Q}_{\text{in}} \eta_{\text{furnace}})_{\text{current}} = (5.5 \times 10^6 \text{ Btu/h})(0.7) = 3.85 \times 10^6 \text{ Btu/h}$$

The boiler must supply useful heat at the same rate after the tune up. Therefore, the rate of heat input to the boiler after the tune up and the rate of energy savings become

$$\dot{Q}_{\text{in,new}} = \dot{Q}_{\text{out}} / \eta_{\text{furnace,new}} = (3.85 \times 10^6 \text{ Btu/h}) / 0.8 = 4.81 \times 10^6 \text{ Btu/h}$$

$$\dot{Q}_{\text{in,saved}} = \dot{Q}_{\text{in,current}} - \dot{Q}_{\text{in,new}} = 5.5 \times 10^6 - 4.81 \times 10^6 = 0.69 \times 10^6 \text{ Btu/h}$$

Then the annual energy and cost savings associated with tuning up the boiler become

$$\begin{aligned} \text{Energy Savings} &= \dot{Q}_{\text{in,saved}} (\text{Operation hours}) \\ &= (0.69 \times 10^6 \text{ Btu/h})(4200 \text{ h/year}) = \mathbf{2.89 \times 10^9 \text{ Btu/yr}} \end{aligned}$$

$$\begin{aligned} \text{Cost Savings} &= (\text{Energy Savings})(\text{Unit cost of energy}) \\ &= (2.89 \times 10^9 \text{ Btu/yr})(\$4.35/10^6 \text{ Btu}) = \mathbf{\$12,600/\text{year}} \end{aligned}$$

Discussion Notice that tuning up the boiler will save \$12,600 a year, which is a significant amount. The implementation cost of this measure is negligible if the adjustment can be made by in-house personnel. Otherwise it is worthwhile to have an authorized representative of the boiler manufacturer to service the boiler twice a year.

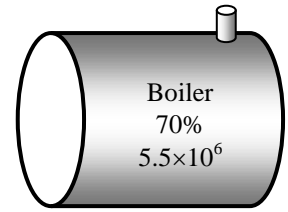



2-60E Problem 2-59E is reconsidered. The effects of the unit cost of energy and combustion efficiency on the annual energy used and the cost savings as the efficiency varies from 0.7 to 0.9 and the unit cost varies from \$4 to \$6 per million Btu are the investigated. The annual energy saved and the cost savings are to be plotted against the efficiency for unit costs of \$4, \$5, and \$6 per million Btu.

Analysis The problem is solved using EES, and the solution is given below.

"Given"

$Q_{\text{dot_in_current}}=5.5\text{E}6$ [Btu/h]
 $\eta_{\text{furnace_current}}=0.7$
 $\eta_{\text{furnace_new}}=0.8$
 Hours=4200 [h/year]
 $\text{UnitCost}=4.35\text{E}-6$ [\$/Btu]

"Analysis"

$Q_{\text{dot_out}}=Q_{\text{dot_in_current}}*\eta_{\text{furnace_current}}$
 $Q_{\text{dot_in_new}}=Q_{\text{dot_out}}/\eta_{\text{furnace_new}}$
 $Q_{\text{dot_in_saved}}=Q_{\text{dot_in_current}}-Q_{\text{dot_in_new}}$
 $\text{EnergySavings}=Q_{\text{dot_in_saved}}*\text{Hours}$
 $\text{CostSavings}=\text{EnergySavings}*\text{UnitCost}$

$\eta_{\text{furnace,new}}$	EnergySavings [Btu/year]	CostSavings [\$/year]
0.7	0.00E+00	0
0.72	6.42E+08	3208
0.74	1.25E+09	6243
0.76	1.82E+09	9118
0.78	2.37E+09	11846
0.8	2.89E+09	14437
0.82	3.38E+09	16902
0.84	3.85E+09	19250
0.86	4.30E+09	21488
0.88	4.73E+09	23625
0.9	5.13E+09	25667

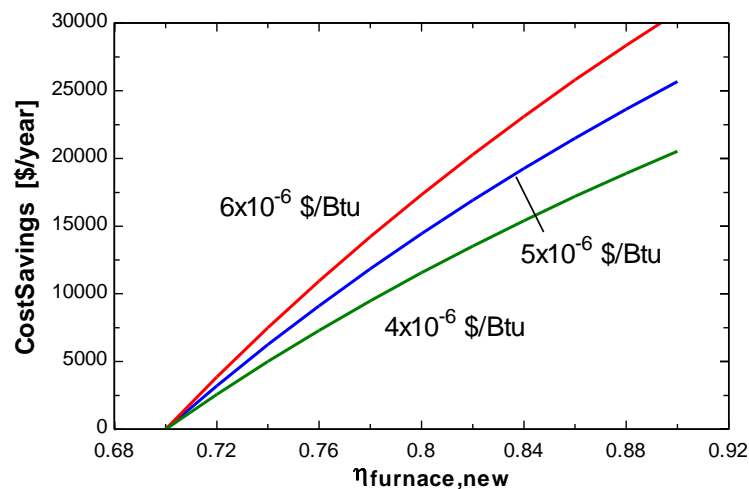
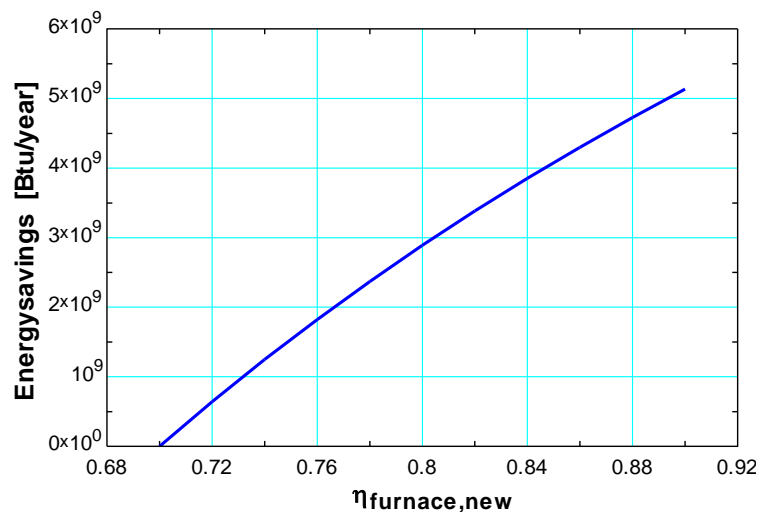

Table values are for UnitCost = $5\text{E}-5$ [\$/Btu]

2-61 Geothermal water is raised from a given depth by a pump at a specified rate. For a given pump efficiency, the required power input to the pump is to be determined.

Assumptions 1 The pump operates steadily. 2 Frictional losses in the pipes are negligible. 3 The changes in kinetic energy are negligible. 4 The geothermal water is exposed to the atmosphere and thus its free surface is at atmospheric pressure.

Properties The density of geothermal water is given to be $\rho = 1050 \text{ kg/m}^3$.

Analysis The elevation of geothermal water and thus its potential energy changes, but it experiences no changes in its velocity and pressure. Therefore, the change in the total mechanical energy of geothermal water is equal to the change in its potential energy, which is gz per unit mass, and $\dot{m}gz$ for a given mass flow rate. That is,

$$\begin{aligned}\Delta \dot{E}_{\text{mech}} &= \dot{m} \Delta e_{\text{mech}} = \dot{m} \Delta pe = \dot{m} g \Delta z = \rho \dot{V} g \Delta z \\ &= (1050 \text{ kg/m}^3)(0.3 \text{ m}^3/\text{s})(9.81 \text{ m/s}^2)(200 \text{ m}) \left(\frac{1 \text{ N}}{1 \text{ kg} \cdot \text{m/s}^2} \right) \left(\frac{1 \text{ kW}}{1000 \text{ N} \cdot \text{m/s}} \right) \\ &= 618.0 \text{ kW}\end{aligned}$$

Then the required power input to the pump becomes

$$\dot{W}_{\text{pump,elect}} = \frac{\Delta \dot{E}_{\text{mech}}}{\eta_{\text{pump-motor}}} = \frac{618 \text{ kW}}{0.74} = \mathbf{835 \text{ kW}}$$

Discussion The frictional losses in piping systems are usually significant, and thus a larger pump will be needed to overcome these frictional losses.

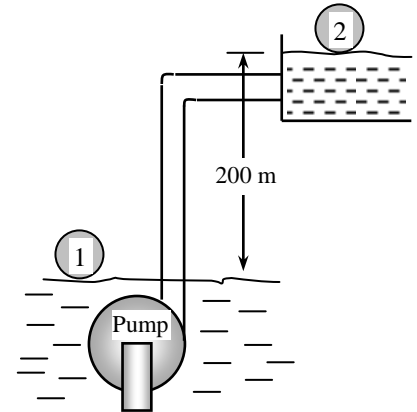

2-62 Several people are working out in an exercise room. The rate of heat gain from people and the equipment is to be determined.

Assumptions The average rate of heat dissipated by people in an exercise room is 600 W.

Analysis The 6 weight lifting machines do not have any motors, and thus they do not contribute to the internal heat gain directly. The usage factors of the motors of the treadmills are taken to be unity since they are used constantly during peak periods. Noting that 1 hp = 745.7 W, the total heat generated by the motors is

$$\begin{aligned}\dot{Q}_{\text{motors}} &= (\text{No. of motors}) \times \dot{W}_{\text{motor}} \times f_{\text{load}} \times f_{\text{usage}} / \eta_{\text{motor}} \\ &= 7 \times (2.5 \times 746 \text{ W}) \times 0.70 \times 1.0 / 0.77 = 11,870 \text{ W}\end{aligned}$$

The heat gain from 14 people is

$$\dot{Q}_{\text{people}} = 14 \times (600 \text{ W}) = 8400 \text{ W}$$

Then the total rate of heat gain of the exercise room during peak period becomes

$$\dot{Q}_{\text{total}} = \dot{Q}_{\text{motors}} + \dot{Q}_{\text{people}} = 11,870 + 8400 = \mathbf{20,270 \text{ W}}$$



2-63 A room is cooled by circulating chilled water through a heat exchanger, and the air is circulated through the heat exchanger by a fan. The contribution of the fan-motor assembly to the cooling load of the room is to be determined.

Assumptions The fan motor operates at full load so that $f_{load} = 1$.

Analysis The entire electrical energy consumed by the motor, including the shaft power delivered to the fan, is eventually dissipated as heat. Therefore, the contribution of the fan-motor assembly to the cooling load of the room is equal to the electrical energy it consumes,

$$\begin{aligned}\dot{Q}_{\text{internal generation}} &= \dot{W}_{\text{in,electric}} = \dot{W}_{\text{shaft}} / \eta_{\text{motor}} \\ &= (0.25 \text{ hp}) / 0.54 = 0.463 \text{ hp} = \mathbf{345 \text{ W}}\end{aligned}$$

since 1 hp = 746 W.

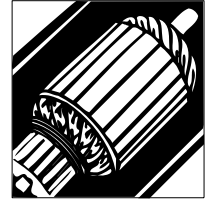

2-64 A hydraulic turbine-generator is to generate electricity from the water of a lake. The overall efficiency, the turbine efficiency, and the shaft power are to be determined.

Assumptions 1 The elevation of the lake and that of the discharge site remains constant. 2 Irreversible losses in the pipes are negligible.

Properties The density of water can be taken to be $\rho = 1000 \text{ kg/m}^3$. The gravitational acceleration is $g = 9.81 \text{ m/s}^2$.

Analysis (a) We take the bottom of the lake as the reference level for convenience. Then kinetic and potential energies of water are zero, and the mechanical energy of water consists of pressure energy only which is

$$\begin{aligned}e_{\text{mech,in}} - e_{\text{mech,out}} &= \frac{P}{\rho} = gh \\ &= (9.81 \text{ m/s}^2)(50 \text{ m}) \left(\frac{1 \text{ kJ/kg}}{1000 \text{ m}^2/\text{s}^2} \right) \\ &= 0.491 \text{ kJ/kg}\end{aligned}$$

Then the rate at which mechanical energy of fluid supplied to the turbine and the overall efficiency become

$$|\Delta \dot{E}_{\text{mech,fluid}}| = \dot{m}(e_{\text{mech,in}} - e_{\text{mech,out}}) = (5000 \text{ kg/s})(0.491 \text{ kJ/kg}) = 2455 \text{ kW}$$

$$\eta_{\text{overall}} = \eta_{\text{turbine-gen}} = \frac{\dot{W}_{\text{elect,out}}}{|\Delta \dot{E}_{\text{mech,fluid}}|} = \frac{1862 \text{ kW}}{2455 \text{ kW}} = \mathbf{0.760}$$

(b) Knowing the overall and generator efficiencies, the mechanical efficiency of the turbine is determined from

$$\eta_{\text{turbine-gen}} = \eta_{\text{turbine}} \eta_{\text{generator}} \rightarrow \eta_{\text{turbine}} = \frac{\eta_{\text{turbine-gen}}}{\eta_{\text{generator}}} = \frac{0.76}{0.95} = \mathbf{0.800}$$

(c) The shaft power output is determined from the definition of mechanical efficiency,

$$\dot{W}_{\text{shaft,out}} = \eta_{\text{turbine}} |\Delta \dot{E}_{\text{mech,fluid}}| = (0.800)(2455 \text{ kW}) = 1964 \text{ kW} \approx \mathbf{1960 \text{ kW}}$$

Therefore, the lake supplies 2455 kW of mechanical energy to the turbine, which converts 1964 kW of it to shaft work that drives the generator, which generates 1862 kW of electric power.

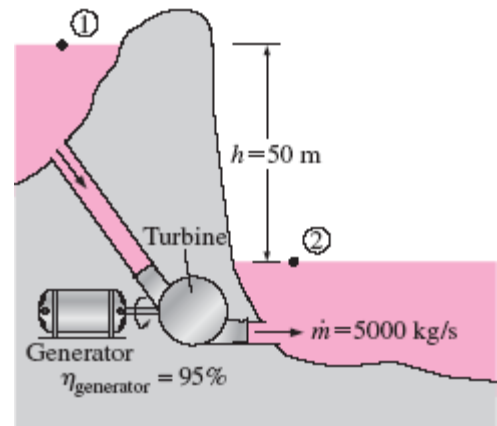

2-65 A pump with a specified shaft power and efficiency is used to raise water to a higher elevation. The maximum flow rate of water is to be determined.

Assumptions 1 The flow is steady and incompressible. **2** The elevation difference between the reservoirs is constant. **3** We assume the flow in the pipes to be *frictionless* since the *maximum* flow rate is to be determined,

Properties We take the density of water to be $\rho = 1000 \text{ kg/m}^3$.

Analysis The useful pumping power (the part converted to mechanical energy of water) is

$$\dot{W}_{\text{pump,u}} = \eta_{\text{pump}} \dot{W}_{\text{pump,shaft}} = (0.82)(7 \text{ hp}) = 5.74 \text{ hp}$$

The elevation of water and thus its potential energy changes during pumping, but it experiences no changes in its velocity and pressure. Therefore, the change in the total mechanical energy of water is equal to the change in its potential energy, which is gz per unit mass, and $\dot{m}gz$ for a given mass flow rate. That is,

$$\Delta \dot{E}_{\text{mech}} = \dot{m} \Delta e_{\text{mech}} = \dot{m} \Delta pe = \dot{m} g \Delta z = \rho \dot{V} g \Delta z$$

Noting that $\Delta \dot{E}_{\text{mech}} = \dot{W}_{\text{pump,u}}$, the volume flow rate of water is determined to be

$$\dot{V} = \frac{\dot{W}_{\text{pump,u}}}{\rho g z_2} = \frac{5.74 \text{ hp}}{(1000 \text{ kg/m}^3)(9.81 \text{ m/s}^2)(15 \text{ m})} \left(\frac{745.7 \text{ W}}{1 \text{ hp}} \right) \left(\frac{1 \text{ N} \cdot \text{m/s}}{1 \text{ W}} \right) \left(\frac{1 \text{ kg} \cdot \text{m/s}^2}{1 \text{ N}} \right) = \mathbf{0.0291 \text{ m}^3/\text{s}}$$

Discussion This is the maximum flow rate since the frictional effects are ignored. In an actual system, the flow rate of water will be less because of friction in pipes.

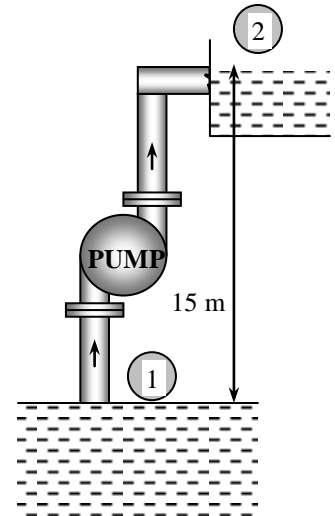

2-66 Wind is blowing steadily at a certain velocity. The mechanical energy of air per unit mass, the power generation potential, and the actual electric power generation are to be determined.

Assumptions 1 The wind is blowing steadily at a constant uniform velocity. **2** The efficiency of the wind turbine is independent of the wind speed.

Properties The density of air is given to be $\rho = 1.25 \text{ kg/m}^3$.

Analysis Kinetic energy is the only form of mechanical energy the wind possesses, and it can be converted to work entirely. Therefore, the power potential of the wind is its kinetic energy, which is $V^2/2$ per unit mass, and $\dot{m}V^2/2$ for a given mass flow rate:

$$e_{\text{mech}} = ke = \frac{V^2}{2} = \frac{(7 \text{ m/s})^2}{2} \left(\frac{1 \text{ kJ/kg}}{1000 \text{ m}^2/\text{s}^2} \right) = 0.0245 \text{ kJ/kg}$$

$$\dot{m} = \rho VA = \rho V \frac{\pi D^2}{4} = (1.25 \text{ kg/m}^3)(7 \text{ m/s}) \frac{\pi (80 \text{ m})^2}{4} = 43,982 \text{ kg/s}$$

$$\dot{W}_{\text{max}} = \dot{E}_{\text{mech}} = \dot{m} e_{\text{mech}} = (43,982 \text{ kg/s})(0.0245 \text{ kJ/kg}) = \mathbf{1078 \text{ kW}}$$

The actual electric power generation is determined by multiplying the power generation potential by the efficiency,

$$\dot{W}_{\text{elect}} = \eta_{\text{wind turbine}} \dot{W}_{\text{max}} = (0.30)(1078 \text{ kW}) = \mathbf{323 \text{ kW}}$$

Therefore, 323 kW of actual power can be generated by this wind turbine at the stated conditions.

Discussion The power generation of a wind turbine is proportional to the cube of the wind velocity, and thus the power generation will change strongly with the wind conditions.

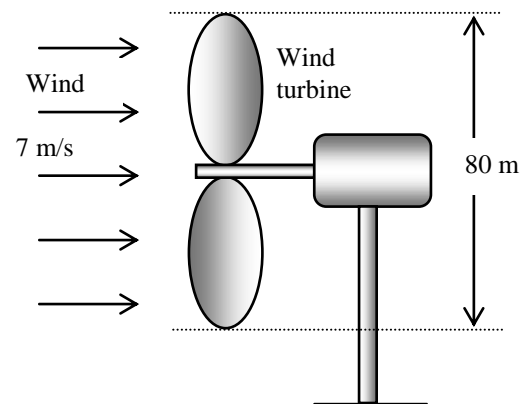



2-67 Problem 2-66 is reconsidered. The effect of wind velocity and the blade span diameter on wind power generation as the velocity varies from 5 m/s to 20 m/s in increments of 5 m/s, and the diameter varies from 20 m to 120 m in increments of 20 m is to be investigated.

Analysis The problem is solved using EES, and the solution is given below.

"Given"

$$V=7 \text{ [m/s]}$$

$$D=80 \text{ [m]}$$

$$\eta_{\text{overall}}=0.30$$

$$\rho=1.25 \text{ [kg/m}^3\text{]}$$

"Analysis"

$$g=9.81 \text{ [m/s}^2\text{]}$$

$$A=\pi \cdot D^2/4$$

$$\dot{m}_{\text{dot}}=\rho \cdot A \cdot V$$

$$\dot{W}_{\text{dot_max}}=\dot{m}_{\text{dot}} \cdot V^2/2 \cdot \text{Convert}(\text{m}^2/\text{s}^2, \text{kJ/kg})$$

$$\dot{W}_{\text{dot_elect}}=\eta_{\text{overall}} \cdot \dot{W}_{\text{dot_max}}$$

Table 1	1	2	3	4
1..24	D [m]	V [m/s]	\dot{m} [kg/s]	\dot{W}_{elect} [kW]
Run 1	20	5	1963	7.363
Run 2	20	10	3927	58.9
Run 3	20	15	5890	198.8
Run 4	20	20	7854	471.2
Run 5	40	5	7854	29.45
Run 6	40	10	15708	235.6
Run 7	40	15	23562	795.2
Run 8	40	20	31416	1885
Run 9	60	5	17671	66.27
Run 10	60	10	35343	530.1
Run 11	60	15	53014	1789
Run 12	60	20	70686	4241
Run 13	80	5	31416	117.8
Run 14	80	10	62832	942.5
Run 15	80	15	94248	3181
Run 16	80	20	125664	7540
Run 17	100	5	49087	184.1
Run 18	100	10	98175	1473
Run 19	100	15	147262	4970
Run 20	100	20	196350	11781
Run 21	120	5	70686	265.1
Run 22	120	10	141372	2121
Run 23	120	15	212058	7157
Run 24	120	20	282743	16965

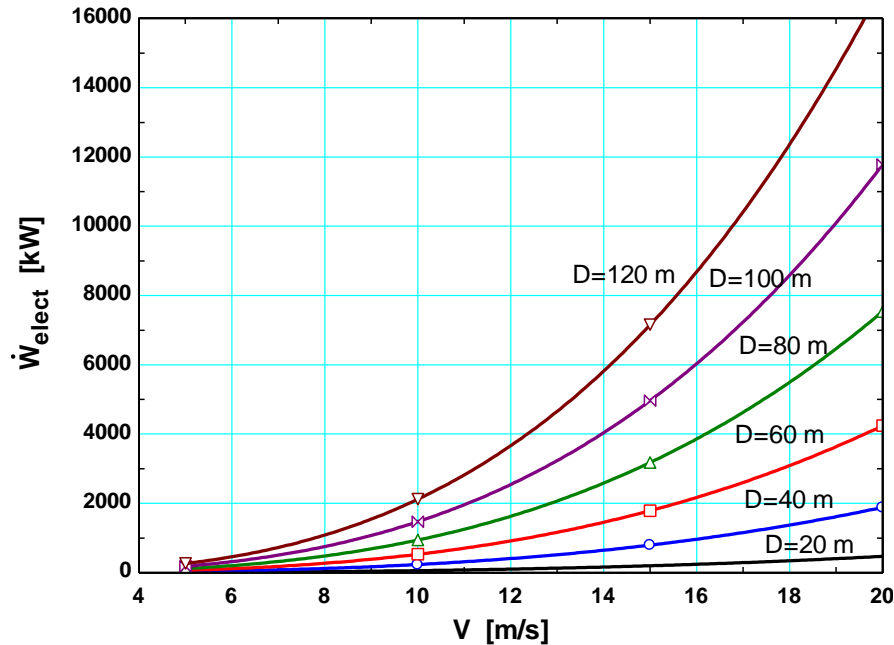

2-68 Water is pumped from a lake to a storage tank at a specified rate. The overall efficiency of the pump-motor unit and the pressure difference between the inlet and the exit of the pump are to be determined.

Assumptions 1 The elevations of the tank and the lake remain constant. **2** Frictional losses in the pipes are negligible. **3** The changes in kinetic energy are negligible. **4** The elevation difference across the pump is negligible.

Properties We take the density of water to be $\rho = 1000 \text{ kg/m}^3$.

Analysis (a) We take the free surface of the lake to be point 1 and the free surfaces of the storage tank to be point 2. We also take the lake surface as the reference level ($z_1 = 0$), and thus the potential energy at points 1 and 2 are $pe_1 = 0$ and $pe_2 = gz_2$. The flow energy at both points is zero since both 1 and 2 are open to the atmosphere ($P_1 = P_2 = P_{\text{atm}}$). Further, the kinetic energy at both points is zero ($ke_1 = ke_2 = 0$) since the water at both locations is essentially stationary. The mass flow rate of water and its potential energy at point 2 are

$$\dot{m} = \rho \dot{V} = (1000 \text{ kg/m}^3)(0.070 \text{ m}^3/\text{s}) = 70 \text{ kg/s}$$

$$pe_2 = gz_2 = (9.81 \text{ m/s}^2)(15 \text{ m}) \left(\frac{1 \text{ kJ/kg}}{1000 \text{ m}^2/\text{s}^2} \right) = 0.1472 \text{ kJ/kg}$$

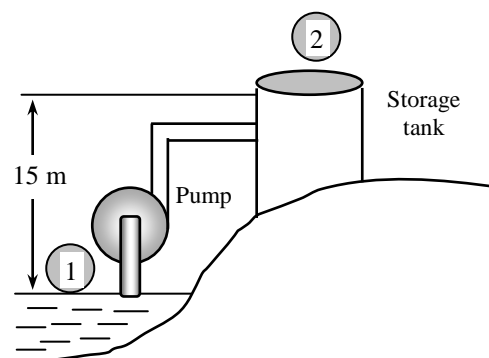

Then the rate of increase of the mechanical energy of water becomes

$$\Delta \dot{E}_{\text{mech,fluid}} = \dot{m}(e_{\text{mech,out}} - e_{\text{mech,in}}) = \dot{m}(pe_2 - 0) = \dot{m}pe_2 = (70 \text{ kg/s})(0.1472 \text{ kJ/kg}) = 10.3 \text{ kW}$$

The overall efficiency of the combined pump-motor unit is determined from its definition,

$$\eta_{\text{pump-motor}} = \frac{\Delta \dot{E}_{\text{mech,fluid}}}{\dot{W}_{\text{elect,in}}} = \frac{10.3 \text{ kW}}{15.4 \text{ kW}} = 0.669 \quad \text{or} \quad \mathbf{66.9\%}$$

(b) Now we consider the pump. The change in the mechanical energy of water as it flows through the pump consists of the change in the flow energy only since the elevation difference across the pump and the change in the kinetic energy are negligible. Also, this change must be equal to the useful mechanical energy supplied by the pump, which is 10.3 kW:

$$\Delta \dot{E}_{\text{mech,fluid}} = \dot{m}(e_{\text{mech,out}} - e_{\text{mech,in}}) = \dot{m} \frac{P_2 - P_1}{\rho} = \dot{V} \Delta P$$

Solving for ΔP and substituting,

$$\Delta P = \frac{\Delta \dot{E}_{\text{mech,fluid}}}{\dot{V}} = \frac{10.3 \text{ kJ/s}}{0.070 \text{ m}^3/\text{s}} \left(\frac{1 \text{ kPa} \cdot \text{m}^3}{1 \text{ kJ}} \right) = \mathbf{147 \text{ kPa}}$$

Therefore, the pump must boost the pressure of water by 147 kPa in order to raise its elevation by 15 m.

Discussion Note that only two-thirds of the electric energy consumed by the pump-motor is converted to the mechanical energy of water; the remaining one-third is wasted because of the inefficiencies of the pump and the motor.

2-69 A large wind turbine is installed at a location where the wind is blowing steadily at a certain velocity. The electric power generation, the daily electricity production, and the monetary value of this electricity are to be determined.

Assumptions 1 The wind is blowing steadily at a constant uniform velocity. **2** The efficiency of the wind turbine is independent of the wind speed.

Properties The density of air is given to be $\rho = 1.25 \text{ kg/m}^3$.

Analysis Kinetic energy is the only form of mechanical energy the wind possesses, and it can be converted to work entirely. Therefore, the power potential of the wind is its kinetic energy, which is $V^2/2$ per unit mass, and $\dot{m}V^2/2$ for a given mass flow rate:

$$e_{\text{mech}} = ke = \frac{V^2}{2} = \frac{(8 \text{ m/s})^2}{2} \left(\frac{1 \text{ kJ/kg}}{1000 \text{ m}^2/\text{s}^2} \right) = 0.032 \text{ kJ/kg}$$

$$\dot{m} = \rho VA = \rho V \frac{\pi D^2}{4} = (1.25 \text{ kg/m}^3)(8 \text{ m/s}) \frac{\pi(100 \text{ m})^2}{4} = 78,540 \text{ kg/s}$$

$$\dot{W}_{\text{max}} = \dot{E}_{\text{mech}} = \dot{m}e_{\text{mech}} = (78,540 \text{ kg/s})(0.032 \text{ kJ/kg}) = 2513 \text{ kW}$$

The actual electric power generation is determined from

$$\dot{W}_{\text{elect}} = \eta_{\text{wind turbine}} \dot{W}_{\text{max}} = (0.32)(2513 \text{ kW}) = \mathbf{804.2 \text{ kW}}$$

Then the amount of electricity generated per day and its monetary value become

$$\text{Amount of electricity} = (\text{Wind power})(\text{Operating hours}) = (804.2 \text{ kW})(24 \text{ h}) = \mathbf{19,300 \text{ kWh}}$$

$$\text{Revenues} = (\text{Amount of electricity})(\text{Unit price}) = (19,300 \text{ kWh})(\$0.09/\text{kWh}) = \mathbf{\$1737} \text{ (per day)}$$

Discussion Note that a single wind turbine can generate several thousand dollars worth of electricity every day at a reasonable cost, which explains the overwhelming popularity of wind turbines in recent years.

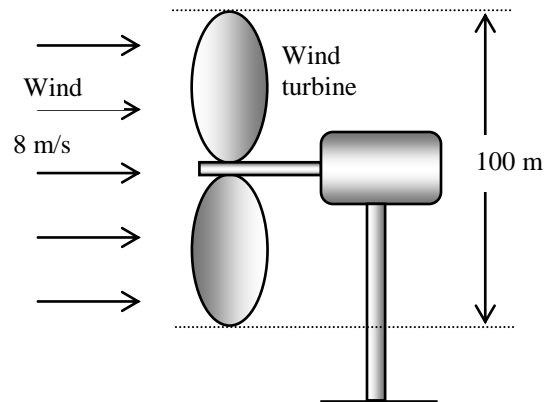

2-70 The available head of a hydraulic turbine and its overall efficiency are given. The electric power output of this turbine is to be determined.

Assumptions 1 The flow is steady and incompressible. **2** The elevation of the reservoir remains constant.

Properties We take the density of water to be $\rho = 1000 \text{ kg/m}^3$.

Analysis The total mechanical energy the water in a reservoir possesses is equivalent to the potential energy of water at the free surface, and it can be converted to work entirely. Therefore, the power potential of water is its potential energy, which is gz per unit mass, and $\dot{m}gz$ for a given mass flow rate. Therefore, the actual power produced by the turbine can be expressed as

$$\dot{W}_{\text{turbine}} = \eta_{\text{turbine}} \dot{m}gh_{\text{turbine}} = \eta_{\text{turbine}} \rho \dot{V}gh_{\text{turbine}}$$

Substituting,

$$\dot{W}_{\text{turbine}} = (0.91)(1000 \text{ kg/m}^3)(0.25 \text{ m}^3/\text{s})(9.81 \text{ m/s}^2)(85 \text{ m}) \left(\frac{1 \text{ N}}{1 \text{ kg} \cdot \text{m/s}^2} \right) \left(\frac{1 \text{ kW}}{1000 \text{ N} \cdot \text{m/s}} \right) = \mathbf{190 \text{ kW}}$$

Discussion Note that the power output of a hydraulic turbine is proportional to the available elevation difference (turbine head) and the flow rate.

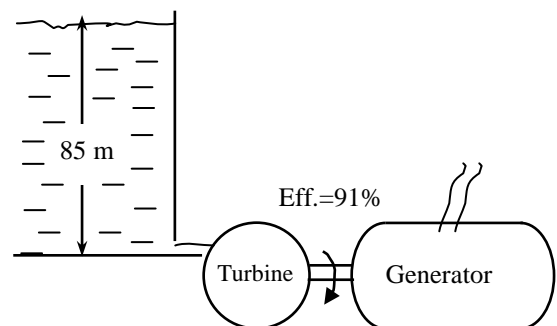

2-71E A water pump raises the pressure of water by a specified amount at a specified flow rate while consuming a known amount of electric power. The mechanical efficiency of the pump is to be determined.

Assumptions 1 The pump operates steadily. 2 The changes in velocity and elevation across the pump are negligible. 3 Water is incompressible.

Analysis To determine the mechanical efficiency of the pump, we need to know the increase in the mechanical energy of the fluid as it flows through the pump, which is

$$\begin{aligned}
 \Delta \dot{E}_{\text{mech,fluid}} &= \dot{m}(e_{\text{mech,out}} - e_{\text{mech,in}}) \\
 &= \dot{m}[(P\boldsymbol{v})_2 - (P\boldsymbol{v})_1] \\
 &= \dot{m}(P_2 - P_1)\boldsymbol{v} \\
 &= \dot{V}(P_2 - P_1) \\
 &= (15 \text{ ft}^3/\text{s})(1.2 \text{ psi}) \left(\frac{1 \text{ Btu}}{5.404 \text{ psi} \cdot \text{ft}^3} \right) \\
 &= 3.33 \text{ Btu/s} = 4.71 \text{ hp}
 \end{aligned}$$

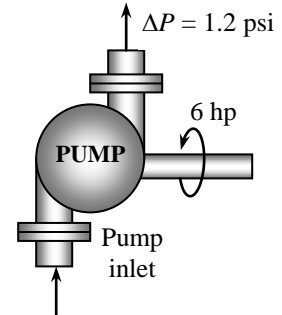

since $1 \text{ hp} = 0.7068 \text{ Btu/s}$, $\dot{m} = \rho \dot{V} = \dot{V} / \boldsymbol{v}$, and there is no change in kinetic and potential energies of the fluid. Then the mechanical efficiency of the pump becomes

$$\eta_{\text{pump}} = \frac{\Delta \dot{E}_{\text{mech,fluid}}}{\dot{W}_{\text{pump,shaft}}} = \frac{4.71 \text{ hp}}{6 \text{ hp}} = 0.786 \quad \text{or} \quad \mathbf{78.6\%}$$

Discussion The overall efficiency of this pump will be lower than 83.8% because of the inefficiency of the electric motor that drives the pump.

2-72 Water is pumped from a lower reservoir to a higher reservoir at a specified rate. For a specified shaft power input, the power that is converted to thermal energy is to be determined.

Assumptions 1 The pump operates steadily. 2 The elevations of the reservoirs remain constant. 3 The changes in kinetic energy are negligible.

Properties We take the density of water to be $\rho = 1000 \text{ kg/m}^3$.

Analysis The elevation of water and thus its potential energy changes during pumping, but it experiences no changes in its velocity and pressure. Therefore, the change in the total mechanical energy of water is equal to the change in its potential energy, which is gz per unit mass, and $\dot{m}gz$ for a given mass flow rate. That is,

$$\begin{aligned}\Delta \dot{E}_{\text{mech}} &= \dot{m} \Delta e_{\text{mech}} = \dot{m} \Delta pe = \dot{m} g \Delta z = \rho \dot{V} g \Delta z \\ &= (1000 \text{ kg/m}^3)(0.03 \text{ m}^3/\text{s})(9.81 \text{ m/s}^2)(45 \text{ m}) \left(\frac{1 \text{ N}}{1 \text{ kg} \cdot \text{m/s}^2} \right) \left(\frac{1 \text{ kW}}{1000 \text{ N} \cdot \text{m/s}} \right) = 13.2 \text{ kW}\end{aligned}$$

Then the mechanical power lost because of frictional effects becomes

$$\dot{W}_{\text{frict}} = \dot{W}_{\text{pump,in}} - \Delta \dot{E}_{\text{mech}} = 20 - 13.2 \text{ kW} = \mathbf{6.8 \text{ kW}}$$

Discussion The 6.8 kW of power is used to overcome the friction in the piping system. The effect of frictional losses in a pump is always to convert mechanical energy to an equivalent amount of thermal energy, which results in a slight rise in fluid temperature. Note that this pumping process could be accomplished by a 13.2 kW pump (rather than 20 kW) if there were no frictional losses in the system. In this ideal case, the pump would function as a turbine when the water is allowed to flow from the upper reservoir to the lower reservoir and extract 13.2 kW of power from the water.

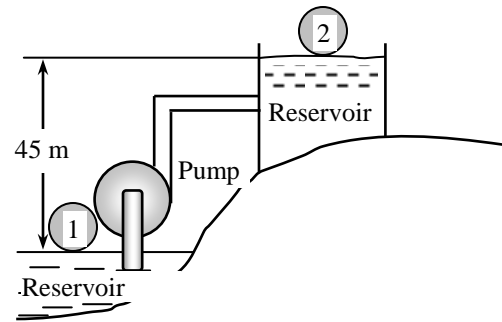

2-73 The mass flow rate of water through the hydraulic turbines of a dam is to be determined.

Analysis The mass flow rate is determined from

$$\dot{W} = \dot{m}g(z_2 - z_1) \longrightarrow \dot{m} = \frac{\dot{W}}{g(z_2 - z_1)} = \frac{100,000 \text{ kJ/s}}{(9.8 \text{ m/s}^2)(206 - 0) \text{ m} \left(\frac{1 \text{ kJ/kg}}{1000 \text{ m}^2/\text{s}^2} \right)} = \mathbf{49,500 \text{ kg/s}}$$

2-74 A pump is pumping oil at a specified rate. The pressure rise of oil in the pump is measured, and the motor efficiency is specified. The mechanical efficiency of the pump is to be determined.

Assumptions 1 The flow is steady and incompressible. 2 The elevation difference across the pump is negligible.

Properties The density of oil is given to be $\rho = 860 \text{ kg/m}^3$.

Analysis Then the total mechanical energy of a fluid is the sum of the potential, flow, and kinetic energies, and is expressed per unit mass as $e_{\text{mech}} = gh + Pv + V^2/2$. To determine the mechanical efficiency of the pump, we need to know the increase in the mechanical energy of the fluid as it flows through the pump, which is

$$\Delta \dot{E}_{\text{mech,fluid}} = \dot{m}(e_{\text{mech,out}} - e_{\text{mech,in}}) = \dot{m} \left[(Pv)_2 + \frac{V_2^2}{2} - (Pv)_1 - \frac{V_1^2}{2} \right] = \dot{V} \left[(P_2 - P_1) + \rho \frac{V_2^2 - V_1^2}{2} \right]$$

since $\dot{m} = \rho \dot{V} = \dot{V}/v$, and there is no change in the potential energy of the fluid. Also,

$$V_1 = \frac{\dot{V}}{A_1} = \frac{\dot{V}}{\pi D_1^2 / 4} = \frac{0.1 \text{ m}^3/\text{s}}{\pi (0.08 \text{ m})^2 / 4} = 19.9 \text{ m/s}$$

$$V_2 = \frac{\dot{V}}{A_2} = \frac{\dot{V}}{\pi D_2^2 / 4} = \frac{0.1 \text{ m}^3/\text{s}}{\pi (0.12 \text{ m})^2 / 4} = 8.84 \text{ m/s}$$

Substituting, the useful pumping power is determined to be

$$\begin{aligned} \dot{W}_{\text{pump,u}} &= \Delta \dot{E}_{\text{mech,fluid}} \\ &= (0.1 \text{ m}^3/\text{s}) \left[500 \text{ kN/m}^2 + (860 \text{ kg/m}^3) \frac{(8.84 \text{ m/s})^2 - (19.9 \text{ m/s})^2}{2} \right] \left(\frac{1 \text{ kN}}{1000 \text{ kg} \cdot \text{m/s}^2} \right) \left(\frac{1 \text{ kW}}{1 \text{ kN} \cdot \text{m/s}} \right) \\ &= 36.3 \text{ kW} \end{aligned}$$

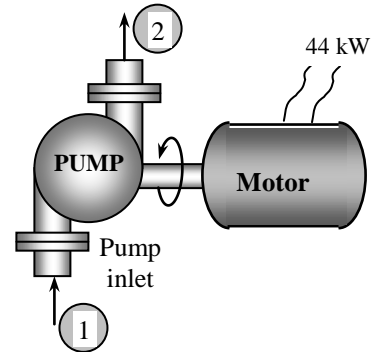

Then the shaft power and the mechanical efficiency of the pump become

$$\dot{W}_{\text{pump,shaft}} = \eta_{\text{motor}} \dot{W}_{\text{electric}} = (0.90)(44 \text{ kW}) = 39.6 \text{ kW}$$

$$\eta_{\text{pump}} = \frac{\dot{W}_{\text{pump,u}}}{\dot{W}_{\text{pump,shaft}}} = \frac{36.3 \text{ kW}}{39.6 \text{ kW}} = 0.918 = \mathbf{91.8\%}$$

Discussion The overall efficiency of this pump/motor unit is the product of the mechanical and motor efficiencies, which is $0.9 \times 0.918 = 0.826$.

Energy and Environment

2-75C Energy conversion pollutes the soil, the water, and the air, and the environmental pollution is a serious threat to vegetation, wild life, and human health. The emissions emitted during the combustion of fossil fuels are responsible for smog, acid rain, and global warming and climate change. The primary chemicals that pollute the air are hydrocarbons (HC, also referred to as volatile organic compounds, VOC), nitrogen oxides (NO_x), and carbon monoxide (CO). The primary source of these pollutants is the motor vehicles.

2-76C Fossil fuels include small amounts of sulfur. The sulfur in the fuel reacts with oxygen to form sulfur dioxide (SO₂), which is an air pollutant. The sulfur oxides and nitric oxides react with water vapor and other chemicals high in the atmosphere in the presence of sunlight to form sulfuric and nitric acids. The acids formed usually dissolve in the suspended water droplets in clouds or fog. These acid-laden droplets are washed from the air on to the soil by rain or snow. This is known as *acid rain*. It is called “rain” since it comes down with rain droplets.

As a result of acid rain, many lakes and rivers in industrial areas have become too acidic for fish to grow. Forests in those areas also experience a slow death due to absorbing the acids through their leaves, needles, and roots. Even marble structures deteriorate due to acid rain.

2-77C Carbon monoxide, which is a colorless, odorless, poisonous gas that deprives the body's organs from getting enough oxygen by binding with the red blood cells that would otherwise carry oxygen. At low levels, carbon monoxide decreases the amount of oxygen supplied to the brain and other organs and muscles, slows body reactions and reflexes, and impairs judgment. It poses a serious threat to people with heart disease because of the fragile condition of the circulatory system and to fetuses because of the oxygen needs of the developing brain. At high levels, it can be fatal, as evidenced by numerous deaths caused by cars that are warmed up in closed garages or by exhaust gases leaking into the cars.

2-78C Carbon dioxide (CO₂), water vapor, and trace amounts of some other gases such as methane and nitrogen oxides act like a blanket and keep the earth warm at night by blocking the heat radiated from the earth. This is known as the *greenhouse effect*. The greenhouse effect makes life on earth possible by keeping the earth warm. But excessive amounts of these gases disturb the delicate balance by trapping too much energy, which causes the average temperature of the earth to rise and the climate at some localities to change. These undesirable consequences of the greenhouse effect are referred to as *global warming* or *global climate change*. The greenhouse effect can be reduced by reducing the net production of CO₂ by consuming less energy (for example, by buying energy efficient cars and appliances) and planting trees.

2-79C Smog is the brown haze that builds up in a large stagnant air mass, and hangs over populated areas on calm hot summer days. Smog is made up mostly of ground-level ozone (O₃), but it also contains numerous other chemicals, including carbon monoxide (CO), particulate matter such as soot and dust, volatile organic compounds (VOC) such as benzene, butane, and other hydrocarbons. Ground-level ozone is formed when hydrocarbons and nitrogen oxides react in the presence of sunlight in hot calm days. Ozone irritates eyes and damage the air sacs in the lungs where oxygen and carbon dioxide are exchanged, causing eventual hardening of this soft and spongy tissue. It also causes shortness of breath, wheezing, fatigue, headaches, nausea, and aggravate respiratory problems such as asthma.

2-80E A person trades in his Ford Taurus for a Ford Explorer. The extra amount of CO₂ emitted by the Explorer within 5 years is to be determined.

Assumptions The Explorer is assumed to use 850 gallons of gasoline a year compared to 650 gallons for Taurus.

Analysis The extra amount of gasoline the Explorer will use within 5 years is

$$\begin{aligned}\text{Extra Gasoline} &= (\text{Extra per year})(\text{No. of years}) \\ &= (850 - 650 \text{ gal/yr})(5 \text{ yr}) \\ &= 1000 \text{ gal}\end{aligned}$$

$$\begin{aligned}\text{Extra CO}_2 \text{ produced} &= (\text{Extra gallons of gasoline used})(\text{CO}_2 \text{ emission per gallon}) \\ &= (1000 \text{ gal})(19.7 \text{ lbm/gal}) \\ &= \mathbf{19,700 \text{ lbm CO}_2}\end{aligned}$$

Discussion Note that the car we choose to drive has a significant effect on the amount of greenhouse gases produced.

2-81E A household uses fuel oil for heating, and electricity for other energy needs. Now the household reduces its energy use by 15%. The reduction in the CO₂ production this household is responsible for is to be determined.

Properties The amount of CO₂ produced is 1.54 lbm per kWh and 26.4 lbm per gallon of fuel oil (given).

Analysis Noting that this household consumes 14,000 kWh of electricity and 900 gallons of fuel oil per year, the amount of CO₂ production this household is responsible for is

$$\begin{aligned}\text{Amount of CO}_2 \text{ produced} &= (\text{Amount of electricity consumed})(\text{Amount of CO}_2 \text{ per kWh}) \\ &\quad + (\text{Amount of fuel oil consumed})(\text{Amount of CO}_2 \text{ per gallon}) \\ &= (14,000 \text{ kWh/yr})(1.54 \text{ lbm/kWh}) + (900 \text{ gal/yr})(26.4 \text{ lbm/gal}) \\ &= 45,320 \text{ CO}_2 \text{ lbm/year}\end{aligned}$$

Then reducing the electricity and fuel oil usage by 15% will reduce the annual amount of CO₂ production by this household by

$$\begin{aligned}\text{Reduction in CO}_2 \text{ produced} &= (0.15)(\text{Current amount of CO}_2 \text{ production}) \\ &= (0.15)(45,320 \text{ CO}_2 \text{ kg/year}) \\ &= \mathbf{6798 \text{ CO}_2 \text{ lbm/year}}\end{aligned}$$

Therefore, any measure that saves energy also reduces the amount of pollution emitted to the environment.

2-82 A power plant that burns natural gas produces 0.59 kg of carbon dioxide (CO₂) per kWh. The amount of CO₂ production that is due to the refrigerators in a city is to be determined.

Assumptions The city uses electricity produced by a natural gas power plant.

Properties 0.59 kg of CO₂ is produced per kWh of electricity generated (given).

Analysis Noting that there are 300,000 households in the city and each household consumes 700 kWh of electricity for refrigeration, the total amount of CO₂ produced is

$$\begin{aligned}\text{Amount of CO}_2 \text{ produced} &= (\text{Amount of electricity consumed})(\text{Amount of CO}_2 \text{ per kWh}) \\ &= (300,000 \text{ household})(700 \text{ kWh/year household})(0.59 \text{ kg/kWh}) \\ &= 1.23 \times 10^8 \text{ CO}_2 \text{ kg/year} \\ &= \mathbf{123,000 \text{ CO}_2 \text{ ton/year}}\end{aligned}$$

Therefore, the refrigerators in this city are responsible for the production of 123,000 tons of CO₂.

2-83 A power plant that burns coal, produces 1.1 kg of carbon dioxide (CO₂) per kWh. The amount of CO₂ production that is due to the refrigerators in a city is to be determined.

Assumptions The city uses electricity produced by a coal power plant.

Properties 1.1 kg of CO₂ is produced per kWh of electricity generated (given).

Analysis Noting that there are 300,000 households in the city and each household consumes 700 kWh of electricity for refrigeration, the total amount of CO₂ produced is

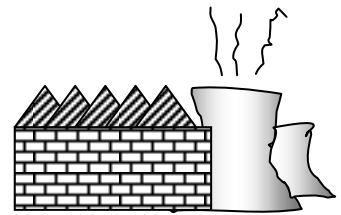

$$\begin{aligned}\text{Amount of CO}_2 \text{ produced} &= (\text{Amount of electricity consumed})(\text{Amount of CO}_2 \text{ per kWh}) \\ &= (300,000 \text{ household})(700 \text{ kWh/household})(1.1 \text{ kg/kWh}) \\ &= 2.31 \times 10^8 \text{ CO}_2 \text{ kg/year} \\ &= \mathbf{231,000 \text{ CO}_2 \text{ ton/year}}\end{aligned}$$

Therefore, the refrigerators in this city are responsible for the production of 231,000 tons of CO₂.

2-84 A household has 2 cars, a natural gas furnace for heating, and uses electricity for other energy needs. The annual amount of NO_x emission to the atmosphere this household is responsible for is to be determined.

Properties The amount of NO_x produced is 7.1 g per kWh, 4.3 g per therm of natural gas, and 11 kg per car (given).

Analysis Noting that this household has 2 cars, consumes 1200 therms of natural gas, and 9,000 kWh of electricity per year, the amount of NO_x production this household is responsible for is



$$\begin{aligned}
 \text{Amount of } \text{NO}_x \text{ produced} &= (\text{No. of cars})(\text{Amount of } \text{NO}_x \text{ produced per car}) \\
 &+ (\text{Amount of electricity consumed})(\text{Amount of } \text{NO}_x \text{ per kWh}) \\
 &+ (\text{Amount of gas consumed})(\text{Amount of } \text{NO}_x \text{ per gallon}) \\
 &= (2 \text{ cars})(11 \text{ kg/car}) + (9000 \text{ kWh/yr})(0.0071 \text{ kg/kWh}) \\
 &\quad + (1200 \text{ therms/yr})(0.0043 \text{ kg/therm}) \\
 &= \mathbf{91.06 \text{ NO}_x \text{ kg/year}}
 \end{aligned}$$

Discussion Any measure that saves energy will also reduce the amount of pollution emitted to the atmosphere.

Special Topic: Mechanisms of Heat Transfer

2-85C The three mechanisms of heat transfer are conduction, convection, and radiation.

2-86C Diamond has a higher thermal conductivity than silver, and thus diamond is a better conductor of heat.

2-87C In forced convection, the fluid is forced to move by external means such as a fan, pump, or the wind. The fluid motion in natural convection is due to buoyancy effects only.

2-88C A blackbody is an idealized body that emits the maximum amount of radiation at a given temperature, and that absorbs all the radiation incident on it. Real bodies emit and absorb less radiation than a blackbody at the same temperature.

2-89C Emissivity is the ratio of the radiation emitted by a surface to the radiation emitted by a blackbody at the same temperature. Absorptivity is the fraction of radiation incident on a surface that is absorbed by the surface. The Kirchhoff's law of radiation states that the emissivity and the absorptivity of a surface are equal at the same temperature and wavelength.

2-90C No. It is purely by radiation.

2-91 The inner and outer surfaces of a brick wall are maintained at specified temperatures. The rate of heat transfer through the wall is to be determined.

Assumptions **1** Steady operating conditions exist since the surface temperatures of the wall remain constant at the specified values. **2** Thermal properties of the wall are constant.

Properties The thermal conductivity of the wall is given to be $k = 0.69 \text{ W/m}\cdot^\circ\text{C}$.

Analysis Under steady conditions, the rate of heat transfer through the wall is

$$\dot{Q}_{\text{cond}} = kA \frac{\Delta T}{L} = (0.69 \text{ W/m}\cdot^\circ\text{C})(5 \times 6 \text{ m}^2) \frac{(20 - 5)^\circ\text{C}}{0.3 \text{ m}} = \mathbf{1035 \text{ W}}$$

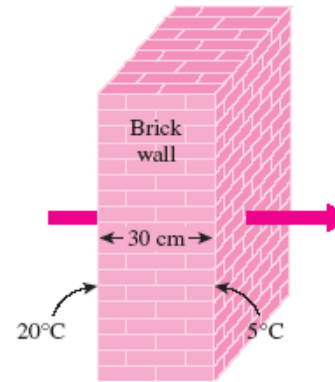

2-92 The inner and outer surfaces of a window glass are maintained at specified temperatures. The amount of heat transferred through the glass in 5 h is to be determined.

Assumptions **1** Steady operating conditions exist since the surface temperatures of the glass remain constant at the specified values. **2** Thermal properties of the glass are constant.

Properties The thermal conductivity of the glass is given to be $k = 0.78 \text{ W/m}\cdot^\circ\text{C}$.

Analysis Under steady conditions, the rate of heat transfer through the glass by conduction is

$$\dot{Q}_{\text{cond}} = kA \frac{\Delta T}{L} = (0.78 \text{ W/m}\cdot^\circ\text{C})(2 \times 2 \text{ m}^2) \frac{(15 - 6)^\circ\text{C}}{0.005 \text{ m}} = 5616 \text{ W}$$

Then the amount of heat transferred over a period of 10 h becomes

$$Q = \dot{Q}_{\text{cond}} \Delta t = (5.616 \text{ kJ/s})(10 \times 3600 \text{ s}) = \mathbf{202,200 \text{ kJ}}$$

If the thickness of the glass is doubled to 1 cm, then the amount of heat transferred will go down by half to **101,100 kJ**.

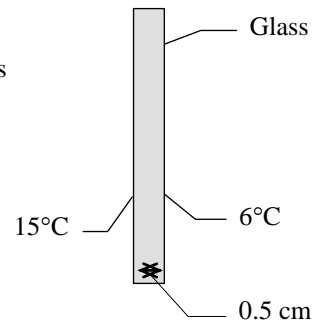



2-93 Reconsider Prob. 2-92. Using EES (or other) software, investigate the effect of glass thickness on heat loss for the specified glass surface temperatures. Let the glass thickness vary from 0.2 cm to 2 cm. Plot the heat loss versus the glass thickness, and discuss the results.

Analysis The problem is solved using EES, and the solution is given below.

```

FUNCTION klookup(material$)
If material$='Glass' then klookup:=0.78
If material$='Brick' then klookup:=0.72
If material$='Fiber Glass' then klookup:=0.043
If material$='Air' then klookup:=0.026
If material$='Wood(oak)' then klookup:=0.17

END

L=2 [m]
W=2 [m]
material$='Glass'
T_in=15 [C]
T_out=6 [C]
k=0.78 [W/m-C]
t=10 [hr]
thickness=0.5 [cm]
A=L*W
Q_dot_loss=A*k*(T_in-T_out)/(thickness*convert(cm,m))
Q_loss_total=Q_dot_loss*t*convert(hr,s)*convert(J,kJ)

```

Thickness [cm]	$Q_{\text{loss,total}}$ [kJ]
0.2	505440
0.4	252720
0.6	168480
0.8	126360
1	101088
1.2	84240
1.4	72206
1.6	63180
1.8	56160
2	50544

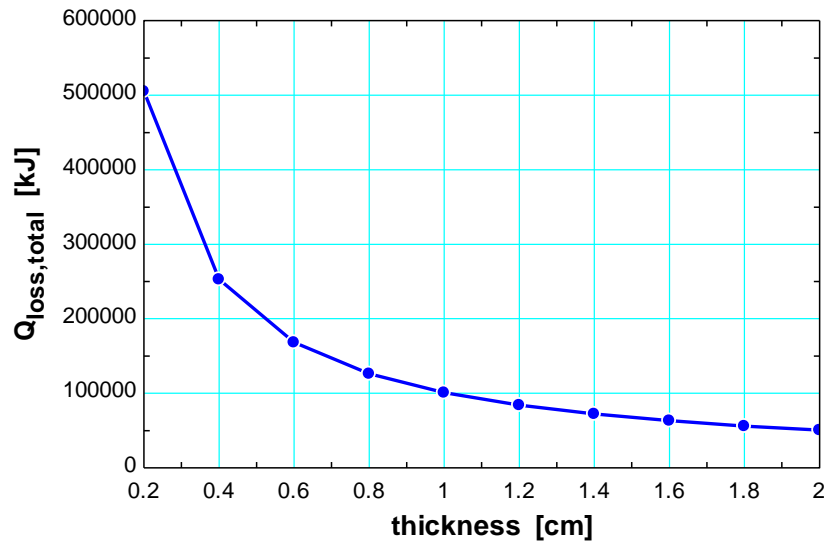

2-94 Heat is transferred steadily to boiling water in the pan through its bottom. The inner surface temperature of the bottom of the pan is given. The temperature of the outer surface is to be determined.

Assumptions 1 Steady operating conditions exist since the surface temperatures of the pan remain constant at the specified values. 2 Thermal properties of the aluminum pan are constant.

Properties The thermal conductivity of the aluminum is given to be $k = 237 \text{ W/m}\cdot\text{C}$.

Analysis The heat transfer surface area is

$$A = \pi r^2 = \pi(0.1 \text{ m})^2 = 0.0314 \text{ m}^2$$

Under steady conditions, the rate of heat transfer through the bottom of the pan by conduction is

$$\dot{Q} = kA \frac{\Delta T}{L} = kA \frac{T_2 - T_1}{L}$$

Substituting,

$$700 \text{ W} = (237 \text{ W/m}\cdot\text{C})(0.0314 \text{ m}^2) \frac{T_2 - 105^\circ\text{C}}{0.006 \text{ m}}$$

which gives

$$T_2 = \mathbf{105.6^\circ\text{C}}$$

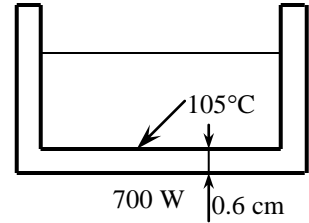

2-95 The inner and outer glasses of a double pane window with a 1-cm air space are at specified temperatures. The rate of heat transfer through the window is to be determined.

Assumptions 1 Steady operating conditions exist since the surface temperatures of the glass remain constant at the specified values. 2 Heat transfer through the window is one-dimensional. 3 Thermal properties of the air are constant. 4 The air trapped between the two glasses is still, and thus heat transfer is by conduction only.

Properties The thermal conductivity of air at room temperature is $k = 0.026 \text{ W/m}\cdot\text{C}$ (Table 2-3).

Analysis Under steady conditions, the rate of heat transfer through the window by conduction is

$$\dot{Q}_{\text{cond}} = kA \frac{\Delta T}{L} = (0.026 \text{ W/m}\cdot\text{C})(2 \times 2 \text{ m}^2) \frac{(18 - 6)^\circ\text{C}}{0.01 \text{ m}} = \mathbf{125 \text{ W} = 0.125 \text{ kW}}$$

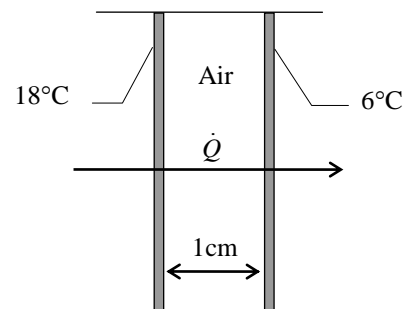

2-96 Two surfaces of a flat plate are maintained at specified temperatures, and the rate of heat transfer through the plate is measured. The thermal conductivity of the plate material is to be determined.

Assumptions 1 Steady operating conditions exist since the surface temperatures of the plate remain constant at the specified values. **2** Heat transfer through the plate is one-dimensional. **3** Thermal properties of the plate are constant.

Analysis The thermal conductivity is determined directly from the steady one-dimensional heat conduction relation to be

$$\dot{Q} = kA \frac{T_1 - T_2}{L}$$

$$k = \frac{(\dot{Q}/A)L}{T_1 - T_2} = \frac{(500 \text{ W/m}^2)(0.02 \text{ m})}{(100 - 0)^\circ\text{C}} = \mathbf{0.1 \text{ W/m}\cdot^\circ\text{C}}$$

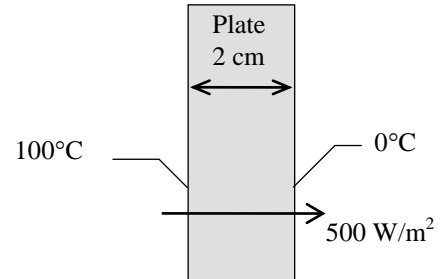

2-97 Hot air is blown over a flat surface at a specified temperature. The rate of heat transfer from the air to the plate is to be determined.

Assumptions 1 Steady operating conditions exist. **2** Heat transfer by radiation is not considered. **3** The convection heat transfer coefficient is constant and uniform over the surface.

Analysis Under steady conditions, the rate of heat transfer by convection is

$$\begin{aligned} \dot{Q}_{\text{conv}} &= hA\Delta T \\ &= (55 \text{ W/m}^2 \cdot ^\circ\text{C})(2 \times 4 \text{ m}^2)(80 - 30)^\circ\text{C} \\ &= \mathbf{22,000 \text{ W} = 22 \text{ kW}} \end{aligned}$$

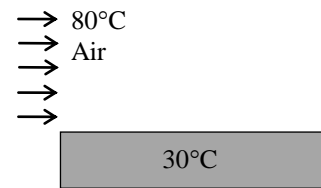

2-98 A person is standing in a room at a specified temperature. The rate of heat transfer between a person and the surrounding air by convection is to be determined.

Assumptions 1 Steady operating conditions exist. **2** Heat transfer by radiation is not considered. **3** The environment is at a uniform temperature.

Analysis The heat transfer surface area of the person is

$$A = \pi DL = \pi(0.3 \text{ m})(1.75 \text{ m}) = 1.649 \text{ m}^2$$

Under steady conditions, the rate of heat transfer by convection is

$$\dot{Q}_{\text{conv}} = hA\Delta T = (10 \text{ W/m}^2 \cdot ^\circ\text{C})(1.649 \text{ m}^2)(34 - 20)^\circ\text{C} = \mathbf{231 \text{ W}}$$

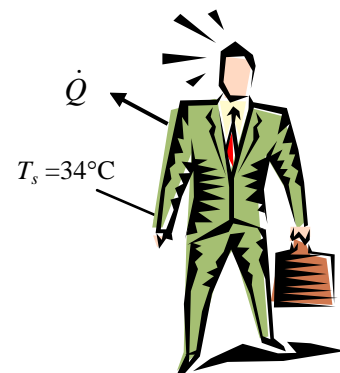

2-99 A spherical ball whose surface is maintained at a temperature of 110°C is suspended in the middle of a room at 20°C . The total rate of heat transfer from the ball is to be determined.

Assumptions 1 Steady operating conditions exist since the ball surface and the surrounding air and surfaces remain at constant temperatures. **2** The thermal properties of the ball and the convection heat transfer coefficient are constant and uniform.

Properties The emissivity of the ball surface is given to be $\varepsilon = 0.8$.

Analysis The heat transfer surface area is

$$A = \pi D^2 = \pi (0.09 \text{ m})^2 = 0.02545 \text{ m}^2$$

Under steady conditions, the rates of convection and radiation heat transfer are

$$\dot{Q}_{\text{conv}} = hA\Delta T = (15 \text{ W/m}^2 \cdot ^{\circ}\text{C})(0.02545 \text{ m}^2)(110 - 20)^{\circ}\text{C} = 34.35 \text{ W}$$

$$\dot{Q}_{\text{rad}} = \varepsilon\sigma A(T_s^4 - T_o^4) = 0.8(0.02545 \text{ m}^2)(5.67 \times 10^{-8} \text{ W/m}^2 \cdot \text{K}^4)[(383 \text{ K})^4 - (293 \text{ K})^4] = 16.33 \text{ W}$$

Therefore,

$$\dot{Q}_{\text{total}} = \dot{Q}_{\text{conv}} + \dot{Q}_{\text{rad}} = 34.35 + 16.33 = \mathbf{50.7 \text{ W}}$$

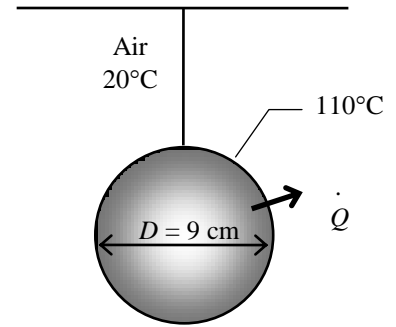



2-100 Reconsider Prob. 2-99. Using EES (or other) software, investigate the effect of the convection heat transfer coefficient and surface emissivity on the heat transfer rate from the ball. Let the heat transfer coefficient vary from 5 $\text{W}/\text{m}^2\cdot^\circ\text{C}$ to 30 $\text{W}/\text{m}^2\cdot^\circ\text{C}$. Plot the rate of heat transfer against the convection heat transfer coefficient for the surface emissivities of 0.1, 0.5, 0.8, and 1, and discuss the results.

Analysis The problem is solved using EES, and the solution is given below.

"Given"

$D=0.09$ [m]
 $T_s=\text{ConvertTemp}(C,K,110)$
 $T_f=\text{ConvertTemp}(C,K,20)$
 $h=15$ [$\text{W}/\text{m}^2\cdot^\circ\text{C}$]
 $\text{epsilon}=0.8$

"Properties"

$\text{sigma}=5.67\text{E}-8$ [$\text{W}/\text{m}^2\cdot\text{K}^4$]

"Analysis"

$A=\text{pi}\cdot D^2$
 $Q_{\text{dot_conv}}=h\cdot A\cdot(T_s-T_f)$
 $Q_{\text{dot_rad}}=\text{epsilon}\cdot\text{sigma}\cdot A\cdot(T_s^4-T_f^4)$
 $Q_{\text{dot_total}}=Q_{\text{dot_conv}}+Q_{\text{dot_rad}}$

h [$\text{W}/\text{m}^2\cdot^\circ\text{C}$]	Q_{total} [W]
5	27.8
7.5	33.53
10	39.25
12.5	44.98
15	50.7
17.5	56.43
20	62.16
22.5	67.88
25	73.61
27.5	79.33
30	85.06

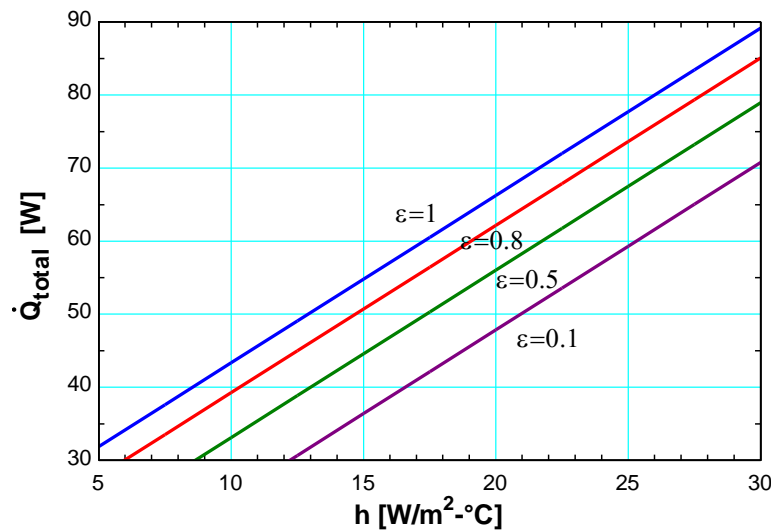

2-101 A 1000-W iron is left on the iron board with its base exposed to the air at 23°C. The temperature of the base of the iron is to be determined in steady operation.

Assumptions 1 Steady operating conditions exist. 2 The thermal properties of the iron base and the convection heat transfer coefficient are constant and uniform. 3 The temperature of the surrounding surfaces is the same as the temperature of the surrounding air.

Properties The emissivity of the base surface is given to be $\varepsilon = 0.4$.

Analysis At steady conditions, the 1000 W of energy supplied to the iron will be dissipated to the surroundings by convection and radiation heat transfer. Therefore,

$$\dot{Q}_{\text{total}} = \dot{Q}_{\text{conv}} + \dot{Q}_{\text{rad}} = 1000 \text{ W}$$

where

$$\dot{Q}_{\text{conv}} = hA\Delta T = (20 \text{ W/m}^2 \cdot \text{K})(0.02 \text{ m}^2)(T_s - 296 \text{ K}) = 0.4(T_s - 296 \text{ K}) \text{ W}$$

and

$$\begin{aligned} \dot{Q}_{\text{rad}} &= \varepsilon\sigma A(T_s^4 - T_o^4) = 0.4(0.02 \text{ m}^2)(5.67 \times 10^{-8} \text{ W/m}^2 \cdot \text{K}^4)[T_s^4 - (296 \text{ K})^4] \\ &= 0.04536 \times 10^{-8} [T_s^4 - (296 \text{ K})^4] \text{ W} \end{aligned}$$

Substituting,

$$1000 \text{ W} = 0.4(T_s - 296 \text{ K}) + 0.04536 \times 10^{-8} [T_s^4 - (296 \text{ K})^4]$$

Solving by trial and error gives

$$T_s = 1106 \text{ K} = \mathbf{833^\circ\text{C}}$$

Discussion We note that the iron will dissipate all the energy it receives by convection and radiation when its surface temperature reaches 1106 K.

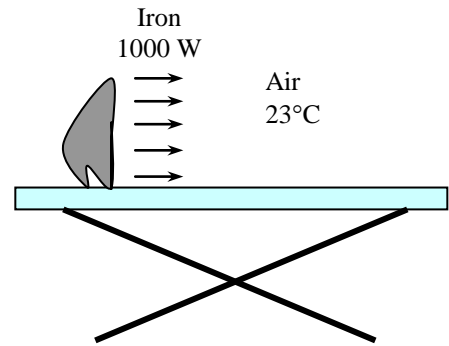

2-102 A hot water pipe at 80°C is losing heat to the surrounding air at 5°C by natural convection with a heat transfer coefficient of 25 W/m²·°C. The rate of heat loss from the pipe by convection is to be determined.

Assumptions 1 Steady operating conditions exist. 2 Heat transfer by radiation is not considered. 3 The convection heat transfer coefficient is constant and uniform over the surface.

Analysis The heat transfer surface area is

$$A = (\pi D)L = \pi(0.07 \text{ m})(18 \text{ m}) = 3.958 \text{ m}^2$$

Under steady conditions, the rate of heat transfer by convection is

$$\dot{Q}_{\text{conv}} = hA\Delta T = (25 \text{ W/m}^2 \cdot ^\circ\text{C})(3.958 \text{ m}^2)(80 - 5)^\circ\text{C} = 7422 \text{ W} = \mathbf{7.42 \text{ kW}}$$

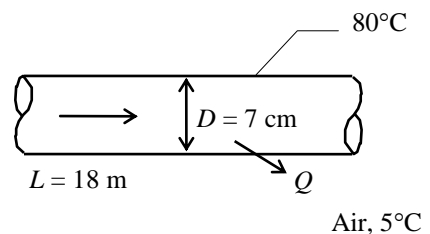

2-103 The backside of the thin metal plate is insulated and the front side is exposed to solar radiation. The surface temperature of the plate is to be determined when it stabilizes.

Assumptions **1** Steady operating conditions exist. **2** Heat transfer through the insulated side of the plate is negligible. **3** The heat transfer coefficient is constant and uniform over the plate. **4** Heat loss by radiation is negligible.

Properties The solar absorptivity of the plate is given to be $\alpha = 0.8$.

Analysis When the heat loss from the plate by convection equals the solar radiation absorbed, the surface temperature of the plate can be determined from

$$\begin{aligned}\dot{Q}_{\text{solarabsorbed}} &= \dot{Q}_{\text{conv}} \\ \alpha \dot{Q}_{\text{solar}} &= hA(T_s - T_o) \\ 0.8 \times A \times 450 \text{ W/m}^2 &= (50 \text{ W/m}^2 \cdot ^\circ\text{C})A(T_s - 25)\end{aligned}$$

Canceling the surface area A and solving for T_s gives

$$T_s = \mathbf{32.2^\circ\text{C}}$$

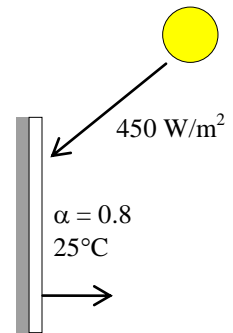



2-104 Reconsider Prob. 2-103. Using EES (or other) software, investigate the effect of the convection heat transfer coefficient on the surface temperature of the plate. Let the heat transfer coefficient vary from $10 \text{ W/m}^2\cdot\text{C}$ to $90 \text{ W/m}^2\cdot\text{C}$. Plot the surface temperature against the convection heat transfer coefficient, and discuss the results.

Analysis The problem is solved using EES, and the solution is given below.

"Given"

alpha=0.8
 q_dot_solar=450 [W/m^2]
 T_f=25 [C]
 h=50 [W/m^2-C]

"Analysis"

q_dot_solarabsorbed=alpha*q_dot_solar
 q_dot_conv=h*(T_s-T_f)
 q_dot_solarabsorbed=q_dot_conv

h [W/m ² -C]	T _s [C]
10	61
15	49
20	43
25	39.4
30	37
35	35.29
40	34
45	33
50	32.2
55	31.55
60	31
65	30.54
70	30.14
75	29.8
80	29.5
85	29.24
90	29

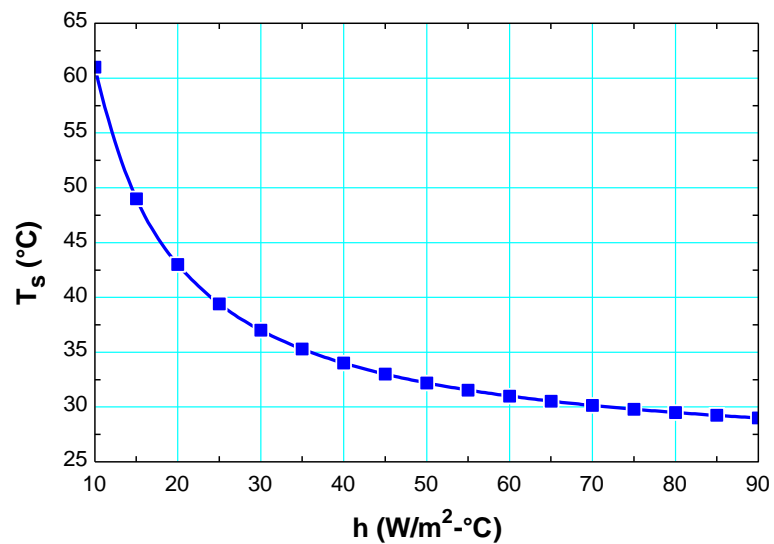

2-105 A spacecraft in space absorbs solar radiation while losing heat to deep space by thermal radiation. The surface temperature of the spacecraft is to be determined when steady conditions are reached..

Assumptions **1** Steady operating conditions exist since the surface temperatures of the wall remain constant at the specified values. **2** Thermal properties of the spacecraft are constant.

Properties The outer surface of a spacecraft has an emissivity of 0.6 and an absorptivity of 0.2.

Analysis When the heat loss from the outer surface of the spacecraft by radiation equals the solar radiation absorbed, the surface temperature can be determined from

$$\begin{aligned}\dot{Q}_{\text{solarabsorbed}} &= \dot{Q}_{\text{rad}} \\ \alpha \dot{Q}_{\text{solar}} &= \varepsilon \sigma A (T_s^4 - T_{\text{space}}^4) \\ 0.2 \times A \times (1000 \text{ W/m}^2) &= 0.6 \times A \times (5.67 \times 10^{-8} \text{ W/m}^2 \cdot \text{K}^4) [T_s^4 - (0 \text{ K})^4]\end{aligned}$$

Canceling the surface area A and solving for T_s gives

$$T_s = \mathbf{276.9\text{K}}$$

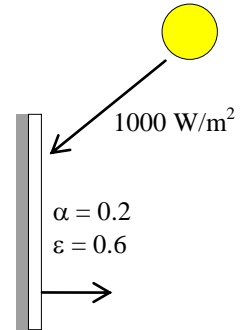



2-106 Reconsider Prob. 2-105. Using EES (or other) software, investigate the effect of the surface emissivity and absorptivity of the spacecraft on the equilibrium surface temperature. Plot the surface temperature against emissivity for solar absorptivities of 0.1, 0.5, 0.8, and 1, and discuss the results.

Analysis The problem is solved using EES, and the solution is given below.

"Given"

epsilon=0.2
 alpha=0.6
 q_dot_solar=1000 [W/m^2]
 T_f=0 [K] "space temperature"

"Properties"

sigma=5.67E-8 [W/m^2-K^4]

"Analysis"

q_dot_solarabsorbed=alpha*q_dot_solar
 q_dot_rad=epsilon*sigma*(T_s^4-T_f^4)
 q_dot_solarabsorbed=q_dot_rad

ϵ	T_s [K]
0.1	648
0.2	544.9
0.3	492.4
0.4	458.2
0.5	433.4
0.6	414.1
0.7	398.4
0.8	385.3
0.9	374.1
1	364.4

Table for $\epsilon = 1$

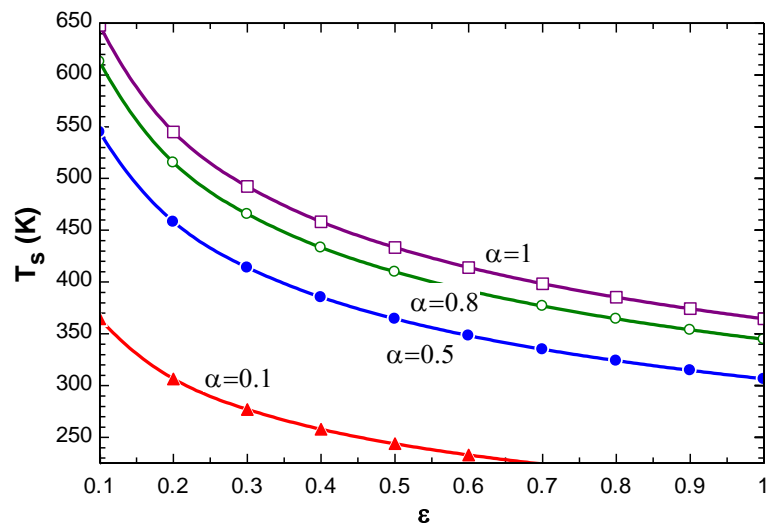

2-107 A hollow spherical iron container is filled with iced water at 0°C . The rate of heat loss from the sphere and the rate at which ice melts in the container are to be determined.

Assumptions **1** Steady operating conditions exist since the surface temperatures of the wall remain constant at the specified values. **2** Heat transfer through the shell is one-dimensional. **3** Thermal properties of the iron shell are constant. **4** The inner surface of the shell is at the same temperature as the iced water, 0°C .

Properties The thermal conductivity of iron is $k = 80.2 \text{ W/m}\cdot^{\circ}\text{C}$ (Table 2-3). The heat of fusion of water is at 1 atm is 333.7 kJ/kg .

Analysis This spherical shell can be approximated as a plate of thickness 0.4 cm and surface area

$$A = \pi D^2 = \pi (0.4 \text{ m})^2 = 0.5027 \text{ m}^2$$

Then the rate of heat transfer through the shell by conduction is

$$\dot{Q}_{\text{cond}} = kA \frac{\Delta T}{L} = (80.2 \text{ W/m}\cdot^{\circ}\text{C})(0.5027 \text{ m}^2) \frac{(3 - 0)^{\circ}\text{C}}{0.004 \text{ m}} = \mathbf{30,235 \text{ W}}$$

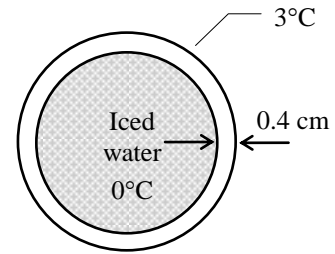

Considering that it takes 333.7 kJ of energy to melt 1 kg of ice at 0°C , the rate at which ice melts in the container can be determined from

$$\dot{m}_{\text{ice}} = \frac{\dot{Q}}{h_{if}} = \frac{30.235 \text{ kJ/s}}{333.7 \text{ kJ/kg}} = \mathbf{0.0906 \text{ kg/s}}$$

Discussion We should point out that this result is slightly in error for approximating a curved wall as a plain wall. The error in this case is very small because of the large diameter to thickness ratio. For better accuracy, we could use the inner surface area ($D = 39.2 \text{ cm}$) or the mean surface area ($D = 39.6 \text{ cm}$) in the calculations.

Review Problems

2-108 The weight of the cabin of an elevator is balanced by a counterweight. The power needed when the fully loaded cabin is rising, and when the empty cabin is descending at a constant speed are to be determined.

Assumptions **1** The weight of the cables is negligible. **2** The guide rails and pulleys are frictionless. **3** Air drag is negligible.

Analysis (a) When the cabin is fully loaded, half of the weight is balanced by the counterweight. The power required to raise the cabin at a constant speed of 1.2 m/s is

$$\dot{W} = \frac{mgz}{\Delta t} = mgV = (400 \text{ kg})(9.81 \text{ m/s}^2)(1.2 \text{ m/s}) \left(\frac{1 \text{ N}}{1 \text{ kg} \cdot \text{m/s}^2} \right) \left(\frac{1 \text{ kW}}{1000 \text{ N} \cdot \text{m/s}} \right) = \mathbf{4.71 \text{ kW}}$$

If no counterweight is used, the mass would double to 800 kg and the power would be $2 \times 4.71 = \mathbf{9.42 \text{ kW}}$.

(b) When the empty cabin is descending (and the counterweight is ascending) there is mass imbalance of $400 - 150 = 250 \text{ kg}$. The power required to raise this mass at a constant speed of 1.2 m/s is

$$\dot{W} = \frac{mgz}{\Delta t} = mgV = (250 \text{ kg})(9.81 \text{ m/s}^2)(1.2 \text{ m/s}) \left(\frac{1 \text{ N}}{1 \text{ kg} \cdot \text{m/s}^2} \right) \left(\frac{1 \text{ kW}}{1000 \text{ N} \cdot \text{m/s}} \right) = \mathbf{2.94 \text{ kW}}$$

If a friction force of 800 N develops between the cabin and the guide rails, we will need

$$\dot{W}_{\text{friction}} = \frac{F_{\text{friction}}z}{\Delta t} = F_{\text{friction}}V = (800 \text{ N})(1.2 \text{ m/s}) \left(\frac{1 \text{ kW}}{1000 \text{ N} \cdot \text{m/s}} \right) = 0.96 \text{ kW}$$

of additional power to combat friction which always acts in the opposite direction to motion. Therefore, the total power needed in this case is

$$\dot{W}_{\text{total}} = \dot{W} + \dot{W}_{\text{friction}} = 2.94 + 0.96 = \mathbf{3.90 \text{ kW}}$$

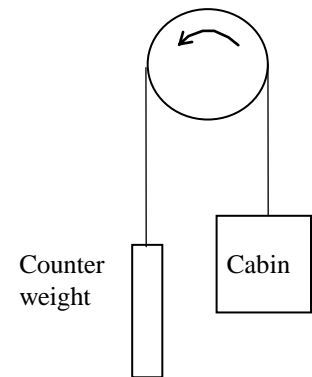

2-109 A decision is to be made between a cheaper but inefficient natural gas heater and an expensive but efficient natural gas heater for a house.

Assumptions The two heaters are comparable in all aspects other than the initial cost and efficiency.

Analysis Other things being equal, the logical choice is the heater that will cost less during its lifetime. The total cost of a system during its lifetime (the initial, operation, maintenance, etc.) can be determined by performing a life cycle cost analysis. A simpler alternative is to determine the simple payback period.

The annual heating cost is given to be \$1200. Noting that the existing heater is 55% efficient, only 55% of that energy (and thus money) is delivered to the house, and the rest is wasted due to the inefficiency of the heater. Therefore, the monetary value of the heating load of the house is

$$\begin{aligned}\text{Cost of useful heat} &= (55\%)(\text{Current annual heating cost}) \\ &= 0.55 \times (\$1200/\text{yr}) = \$660/\text{yr}\end{aligned}$$

Gas Heater $\eta_1 = 82\%$ $\eta_2 = 95\%$
--

This is how much it would cost to heat this house with a heater that is 100% efficient. For heaters that are less efficient, the annual heating cost is determined by dividing \$660 by the efficiency:

82% heater: Annual cost of heating = (Cost of useful heat)/Efficiency = $(\$660/\text{yr})/0.82 = \$805/\text{yr}$

95% heater: Annual cost of heating = (Cost of useful heat)/Efficiency = $(\$660/\text{yr})/0.95 = \$695/\text{yr}$

$$\text{Annual cost savings with the efficient heater} = 805 - 695 = \$110$$

$$\text{Excess initial cost of the efficient heater} = 2700 - 1600 = \$1100$$

The simple payback period becomes

$$\text{Simple payback period} = \frac{\text{Excess initial cost}}{\text{Annual cost savings}} = \frac{\$1100}{\$110/\text{yr}} = \mathbf{10 \text{ years}}$$

Therefore, the more efficient heater will pay for the \$1100 cost differential in this case in 10 years, which is more than the 8-year limit. Therefore, the purchase of the cheaper and less efficient heater is a better buy in this case.

2-110E The energy contents, unit costs, and typical conversion efficiencies of various energy sources for use in water heaters are given. The lowest cost energy source is to be determined.

Assumptions The differences in installation costs of different water heaters are not considered.

Properties The energy contents, unit costs, and typical conversion efficiencies of different systems are given in the problem statement.

Analysis The unit cost of each Btu of useful energy supplied to the water heater by each system can be determined from

$$\text{Unit cost of useful energy} = \frac{\text{Unit cost of energy supplied}}{\text{Conversion efficiency}}$$

Substituting,

$$\text{Natural gas heater:} \quad \text{Unit cost of useful energy} = \frac{\$0.012/\text{ft}^3}{0.85} \left(\frac{1 \text{ ft}^3}{1025 \text{ Btu}} \right) = \$13.8 \times 10^{-6} / \text{Btu}$$

$$\text{Heating by oil heater:} \quad \text{Unit cost of useful energy} = \frac{\$2.2/\text{gal}}{0.75} \left(\frac{1 \text{ gal}}{138,700 \text{ Btu}} \right) = \$21.1 \times 10^{-6} / \text{Btu}$$

$$\text{Electric heater:} \quad \text{Unit cost of useful energy} = \frac{\$0.11/\text{kWh}}{0.90} \left(\frac{1 \text{ kWh}}{3412 \text{ Btu}} \right) = \$35.8 \times 10^{-6} / \text{Btu}$$

Therefore, the lowest cost energy source for hot water heaters in this case is **natural gas**.

2-111 A home owner is considering three different heating systems for heating his house. The system with the lowest energy cost is to be determined.

Assumptions The differences in installation costs of different heating systems are not considered.

Properties The energy contents, unit costs, and typical conversion efficiencies of different systems are given in the problem statement.

Analysis The unit cost of each Btu of useful energy supplied to the house by each system can be determined from

$$\text{Unit cost of useful energy} = \frac{\text{Unit cost of energy supplied}}{\text{Conversion efficiency}}$$

Substituting,

$$\text{Natural gas heater:} \quad \text{Unit cost of useful energy} = \frac{\$1.24/\text{therm}}{0.87} \left(\frac{1 \text{ therm}}{105,500 \text{ kJ}} \right) = \$13.5 \times 10^{-6} / \text{kJ}$$

$$\text{Heating oil heater:} \quad \text{Unit cost of useful energy} = \frac{\$2.3/\text{gal}}{0.87} \left(\frac{1 \text{ gal}}{138,500 \text{ kJ}} \right) = \$19.1 \times 10^{-6} / \text{kJ}$$

$$\text{Electric heater:} \quad \text{Unit cost of useful energy} = \frac{\$0.12/\text{kWh}}{1.0} \left(\frac{1 \text{ kWh}}{3600 \text{ kJ}} \right) = \$33.3 \times 10^{-6} / \text{kJ}$$

Therefore, the system with the lowest energy cost for heating the house is the **natural gas heater**.

2-112 It is estimated that 570,000 barrels of oil would be saved per day if the thermostat setting in residences in winter were lowered by 6°F (3.3°C). The amount of money that would be saved per year is to be determined.

Assumptions The average heating season is given to be 180 days, and the cost of oil to be \$40/barrel.

Analysis The amount of money that would be saved per year is determined directly from

$$(570,000 \text{ barrel/day})(180 \text{ days/year})(\$110/\text{barrel}) = \mathbf{\$11,290,000,000}$$

Therefore, the proposed measure will save more than 11-billion dollars a year in energy costs.

2-113 Caulking and weather-stripping doors and windows to reduce air leaks can reduce the energy use of a house by up to 10 percent. The time it will take for the caulking and weather-stripping to pay for itself from the energy it saves is to be determined.

Assumptions It is given that the annual energy usage of a house is \$1100 a year, and the cost of caulking and weather-stripping a house is \$90.

Analysis The amount of money that would be saved per year is determined directly from

$$\text{Money saved} = (\$1100/\text{year})(0.10) = \mathbf{\$110/\text{yr}}$$

Then the simple payback period becomes

$$\text{Payback period} = \frac{\text{Cost}}{\text{Money saved}} = \frac{\$90}{\$110/\text{yr}} = \mathbf{0.818 \text{ yr}}$$

Therefore, the proposed measure will pay for itself in less than a year.

2-114E The work required to compress a gas in a gas spring is to be determined.

Assumptions All forces except that generated by the gas spring will be neglected.

Analysis When the expression given in the problem statement is substituted into the work integral relation, and advantage is taken of the fact that the force and displacement vectors are collinear, the result is

$$\begin{aligned} W &= \int_1^2 F ds = \int_1^2 \frac{\text{Constant}}{x^k} dx \\ &= \frac{\text{Constant}}{1-k} (x_2^{1-k} - x_1^{1-k}) \\ &= \frac{200 \text{ lbf} \cdot \text{in}^{1.4}}{1-1.4} \left[(7 \text{ in})^{-0.4} - (2 \text{ in})^{-0.4} \right] \left(\frac{1 \text{ ft}}{12 \text{ in}} \right) \\ &= 12.45 \text{ lbf} \cdot \text{ft} \\ &= (12.45 \text{ lbf} \cdot \text{ft}) \left(\frac{1 \text{ Btu}}{778.169 \text{ lbf} \cdot \text{ft}} \right) = \mathbf{0.0160 \text{ Btu}} \end{aligned}$$

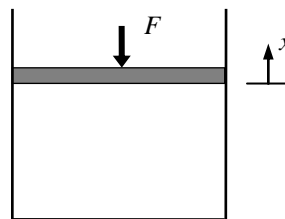

2-115E A man pushes a block along a horizontal plane. The work required to move the block is to be determined considering (a) the man and (b) the block as the system.

Analysis The work applied to the block to overcome the friction is found by using the work integral,

$$\begin{aligned} W &= \int_1^2 F ds = \int_1^2 fW(x_2 - x_1) \\ &= (0.2)(100 \text{ lbf})(100 \text{ ft}) \\ &= 2000 \text{ lbf} \cdot \text{ft} \\ &= (2000 \text{ lbf} \cdot \text{ft}) \left(\frac{1 \text{ Btu}}{778.169 \text{ lbf} \cdot \text{ft}} \right) = \mathbf{2.57 \text{ Btu}} \end{aligned}$$

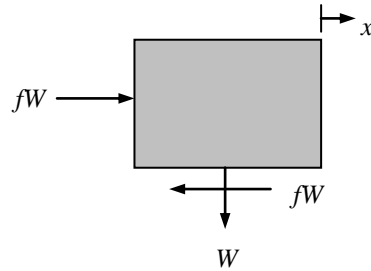

The man must then produce the amount of work

$$W = \mathbf{2.57 \text{ Btu}}$$

2-116 A diesel engine burning light diesel fuel that contains sulfur is considered. The rate of sulfur that ends up in the exhaust and the rate of sulfuric acid given off to the environment are to be determined.

Assumptions **1** All of the sulfur in the fuel ends up in the exhaust. **2** For one kmol of sulfur in the exhaust, one kmol of sulfuric acid is added to the environment.

Properties The molar mass of sulfur is 32 kg/kmol.

Analysis The mass flow rates of fuel and the sulfur in the exhaust are

$$\begin{aligned} \dot{m}_{\text{fuel}} &= \frac{\dot{m}_{\text{air}}}{\text{AF}} = \frac{(336 \text{ kg air/h})}{(18 \text{ kg air/kg fuel})} = 18.67 \text{ kg fuel/h} \\ \dot{m}_{\text{Sulfur}} &= (750 \times 10^{-6}) \dot{m}_{\text{fuel}} = (750 \times 10^{-6})(18.67 \text{ kg/h}) = \mathbf{0.014 \text{ kg/h}} \end{aligned}$$

The rate of sulfuric acid given off to the environment is

$$\dot{m}_{\text{H}_2\text{SO}_3} = \frac{M_{\text{H}_2\text{SO}_3}}{M_{\text{Sulfur}}} \dot{m}_{\text{Sulfur}} = \frac{2 \times 1 + 32 + 3 \times 16}{32} (0.014 \text{ kg/h}) = \mathbf{0.036 \text{ kg/h}}$$

Discussion This problem shows why the sulfur percentage in diesel fuel must be below certain value to satisfy regulations.

2-117 Lead is a very toxic engine emission. Leaded gasoline contains lead that ends up in the exhaust. The amount of lead put out to the atmosphere per year for a given city is to be determined.

Assumptions Entire lead is exhausted to the environment.

Analysis The gasoline consumption and the lead emission are

$$\begin{aligned} \text{Gasoline Consumption} &= (70,000 \text{ cars})(15,000 \text{ km/car} \cdot \text{year})(8.5 \text{ L}/100 \text{ km}) = 8.925 \times 10^7 \text{ L/year} \\ \text{Lead Emission} &= (\text{Gasoline Consumption}) m_{\text{lead}} f_{\text{lead}} \\ &= (8.925 \times 10^7 \text{ L/year})(0.15 \times 10^{-3} \text{ kg/L})(0.50) \\ &= \mathbf{6694 \text{ kg/year}} \end{aligned}$$

Discussion Note that a huge amounts of lead emission is avoided by the use of unleaded gasoline.

2-118 A TV set is kept on a specified number of hours per day. The cost of electricity this TV set consumes per month is to be determined.

Assumptions 1 The month is 30 days. **2** The TV set consumes its rated power when on.

Analysis The total number of hours the TV is on per month is

$$\text{Operating hours} = (6 \text{ h/day})(30 \text{ days}) = 180 \text{ h}$$

Then the amount of electricity consumed per month and its cost become

$$\text{Amount of electricity} = (\text{Power consumed})(\text{Operating hours}) = (0.120 \text{ kW})(180 \text{ h}) = 21.6 \text{ kWh}$$

$$\text{Cost of electricity} = (\text{Amount of electricity})(\text{Unit cost}) = (21.6 \text{ kWh})(\$0.12/\text{kWh}) = \mathbf{\$2.59} \text{ (per month)}$$

Properties Note that an ordinary TV consumes more electricity than a large light bulb, and there should be a conscious effort to turn it off when not in use to save energy.

2-119E The power required to pump a specified rate of water to a specified elevation is to be determined.

Properties The density of water is taken to be 62.4 lbf/ft^3 (Table A-3E).

Analysis The required power is determined from

$$\begin{aligned} \dot{W} &= \dot{m}g(z_2 - z_1) = \rho \dot{V}g(z_2 - z_1) \\ &= (62.4 \text{ lbf/ft}^3)(200 \text{ gal/min}) \left(\frac{35.315 \text{ ft}^3/\text{s}}{15,850 \text{ gal/min}} \right) (32.174 \text{ ft/s}^2)(300 \text{ ft}) \left(\frac{1 \text{ lbf}}{32.174 \text{ lbf} \cdot \text{ft/s}^2} \right) \\ &= 8342 \text{ lbf} \cdot \text{ft/s} = (8342 \text{ lbf} \cdot \text{ft/s}) \left(\frac{1 \text{ kW}}{737.56 \text{ lbf} \cdot \text{ft/s}} \right) = \mathbf{11.3 \text{ kW}} \end{aligned}$$

2-120 The power that could be produced by a water wheel is to be determined.

Properties The density of water is taken to be 1000 kg/m^3 (Table A-3).

Analysis The power production is determined from

$$\begin{aligned} \dot{W} &= \dot{m}g(z_2 - z_1) = \rho \dot{V}g(z_2 - z_1) \\ &= (1000 \text{ kg/m}^3)(0.320/60 \text{ m}^3/\text{s})(9.81 \text{ m/s}^2)(14 \text{ m}) \left(\frac{1 \text{ kJ/kg}}{1000 \text{ m}^2/\text{s}^2} \right) = \mathbf{0.732 \text{ kW}} \end{aligned}$$

2-121 The flow of air through a flow channel is considered. The diameter of the wind channel downstream from the rotor and the power produced by the windmill are to be determined.

Analysis The specific volume of the air is

$$\nu = \frac{RT}{P} = \frac{(0.287 \text{ kPa} \cdot \text{m}^3/\text{kg} \cdot \text{K})(293 \text{ K})}{100 \text{ kPa}} = 0.8409 \text{ m}^3/\text{kg}$$

The diameter of the wind channel downstream from the rotor is

$$\begin{aligned} A_1 V_1 &= A_2 V_2 \longrightarrow (\pi D_1^2 / 4) V_1 = (\pi D_2^2 / 4) V_2 \\ \longrightarrow D_2 &= D_1 \sqrt{\frac{V_1}{V_2}} = (7 \text{ m}) \sqrt{\frac{8 \text{ m/s}}{6.5 \text{ m/s}}} = \mathbf{7.77 \text{ m}} \end{aligned}$$

The mass flow rate through the wind mill is

$$\dot{m} = \frac{A_1 V_1}{\nu} = \frac{\pi (7 \text{ m})^2 (8 \text{ m/s})}{4(0.8409 \text{ m}^3/\text{kg})} = 366.1 \text{ kg/s}$$

The power produced is then

$$\dot{W} = \dot{m} \frac{V_1^2 - V_2^2}{2} = (366.1 \text{ kg/s}) \frac{(8 \text{ m/s})^2 - (6.5 \text{ m/s})^2}{2} \left(\frac{1 \text{ kJ/kg}}{1000 \text{ m}^2/\text{s}^2} \right) = \mathbf{3.98 \text{ kW}}$$

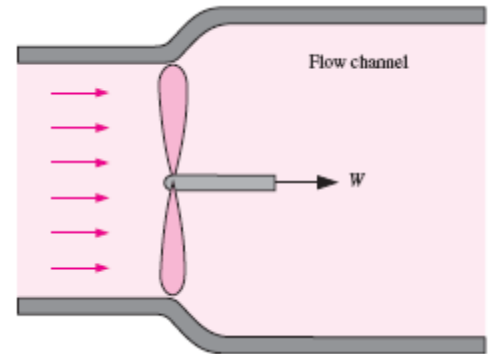

2-122 The available head, flow rate, and efficiency of a hydroelectric turbine are given. The electric power output is to be determined.

Assumptions 1 The flow is steady. 2 Water levels at the reservoir and the discharge site remain constant. 3 Frictional losses in piping are negligible.

Properties We take the density of water to be $\rho = 1000 \text{ kg/m}^3 = 1 \text{ kg/L}$.

Analysis The total mechanical energy the water in a dam possesses is equivalent to the potential energy of water at the free surface of the dam (relative to free surface of discharge water), and it can be converted to work entirely. Therefore, the power potential of water is its potential energy, which is gz per unit mass, and $\dot{m}gz$ for a given mass flow rate.

$$e_{\text{mech}} = pe = gz = (9.81 \text{ m/s}^2)(90 \text{ m}) \left(\frac{1 \text{ kJ/kg}}{1000 \text{ m}^2/\text{s}^2} \right) = 0.8829 \text{ kJ/kg}$$

The mass flow rate is

$$\dot{m} = \rho \dot{V} = (1000 \text{ kg/m}^3)(65 \text{ m}^3/\text{s}) = 65,000 \text{ kg/s}$$

Then the maximum and actual electric power generation become

$$\dot{W}_{\text{max}} = \dot{E}_{\text{mech}} = \dot{m} e_{\text{mech}} = (65,000 \text{ kg/s})(0.8829 \text{ kJ/kg}) \left(\frac{1 \text{ MW}}{1000 \text{ kJ/s}} \right) = 57.39 \text{ MW}$$

$$\dot{W}_{\text{electric}} = \eta_{\text{overall}} \dot{W}_{\text{max}} = 0.84(57.39 \text{ MW}) = \mathbf{48.2 \text{ MW}}$$

Discussion Note that the power generation would increase by more than 1 MW for each percentage point improvement in the efficiency of the turbine-generator unit.

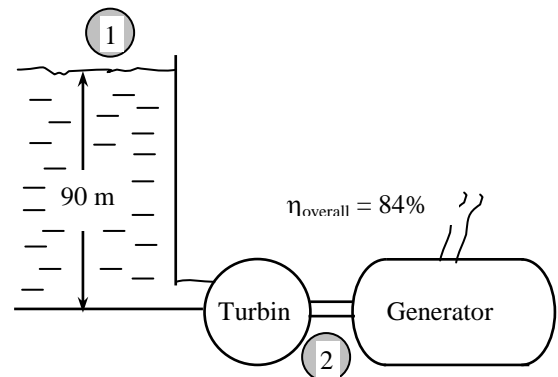

2-123 An entrepreneur is to build a large reservoir above the lake level, and pump water from the lake to the reservoir at night using cheap power, and let the water flow from the reservoir back to the lake during the day, producing power. The potential revenue this system can generate per year is to be determined.

Assumptions **1** The flow in each direction is steady and incompressible. **2** The elevation difference between the lake and the reservoir can be taken to be constant, and the elevation change of reservoir during charging and discharging is disregarded. **3** Frictional losses in piping are negligible. **4** The system operates every day of the year for 10 hours in each mode.

Properties We take the density of water to be $\rho = 1000 \text{ kg/m}^3$.

Analysis The total mechanical energy of water in an upper reservoir relative to water in a lower reservoir is equivalent to the potential energy of water at the free surface of this reservoir relative to free surface of the lower reservoir. Therefore, the power potential of water is its potential energy, which is gz per unit mass, and $\dot{m}gz$ for a given mass flow rate. This also represents the minimum power required to pump water from the lower reservoir to the higher reservoir.

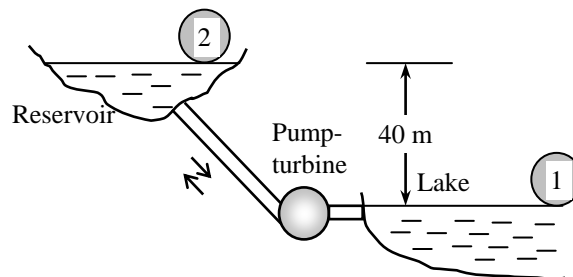

$$\begin{aligned}\dot{W}_{\max, \text{turbine}} = \dot{W}_{\min, \text{pump}} = \dot{W}_{\text{ideal}} = \Delta \dot{E}_{\text{mech}} = \dot{m} \Delta e_{\text{mech}} = \dot{m} \Delta pe = \dot{m} g \Delta z = \rho \dot{V} g \Delta z \\ = (1000 \text{ kg/m}^3)(2 \text{ m}^3/\text{s})(9.81 \text{ m/s}^2)(40 \text{ m}) \left(\frac{1 \text{ N}}{1 \text{ kg} \cdot \text{m/s}^2} \right) \left(\frac{1 \text{ kW}}{1000 \text{ N} \cdot \text{m/s}} \right) \\ = 784.8 \text{ kW}\end{aligned}$$

The actual pump and turbine electric powers are

$$\dot{W}_{\text{pump, elect}} = \frac{\dot{W}_{\text{ideal}}}{\eta_{\text{pump-motor}}} = \frac{784.8 \text{ kW}}{0.75} = 1046 \text{ kW}$$

$$\dot{W}_{\text{turbine}} = \eta_{\text{turbine-gen}} \dot{W}_{\text{ideal}} = 0.75(784.8 \text{ kW}) = 588.6 \text{ kW}$$

Then the power consumption cost of the pump, the revenue generated by the turbine, and the net income (revenue minus cost) per year become

$$\text{Cost} = \dot{W}_{\text{pump, elect}} \Delta t \times \text{Unit price} = (1046 \text{ kW})(365 \times 10 \text{ h/year})(\$0.05/\text{kWh}) = \$190,968/\text{year}$$

$$\text{Revenue} = \dot{W}_{\text{turbine}} \Delta t \times \text{Unit price} = (588.6 \text{ kW})(365 \times 10 \text{ h/year})(\$0.12/\text{kWh}) = \$257,807/\text{year}$$

$$\text{Net income} = \text{Revenue} - \text{Cost} = 257,807 - 190,968 = \mathbf{\$66,839/\text{year}}$$

Discussion It appears that this pump-turbine system has a potential to generate net revenues of about \$67,000 per year. A decision on such a system will depend on the initial cost of the system, its life, the operating and maintenance costs, the interest rate, and the length of the contract period, among other things.

2-124 The pump of a water distribution system is pumping water at a specified flow rate. The pressure rise of water in the pump is measured, and the motor efficiency is specified. The mechanical efficiency of the pump is to be determined.

Assumptions 1 The flow is steady. 2 The elevation difference across the pump is negligible. 3 Water is incompressible.

Analysis From the definition of motor efficiency, the mechanical (shaft) power delivered by the motor is

$$\dot{W}_{\text{pump,shaft}} = \eta_{\text{motor}} \dot{W}_{\text{electric}} = (0.90)(15 \text{ kW}) = 13.5 \text{ kW}$$

To determine the mechanical efficiency of the pump, we need to know the increase in the mechanical energy of the fluid as it flows through the pump, which is

$$\begin{aligned} \Delta \dot{E}_{\text{mech,fluid}} &= \dot{m}(e_{\text{mech,out}} - e_{\text{mech,in}}) = \dot{m}[(Pv)_2 - (Pv)_1] = \dot{m}(P_2 - P_1)v = \dot{V}(P_2 - P_1) \\ &= (0.050 \text{ m}^3/\text{s})(300 - 100 \text{ kPa}) \left(\frac{1 \text{ kJ}}{1 \text{ kPa} \cdot \text{m}^3} \right) = 10 \text{ kJ/s} = 10 \text{ kW} \end{aligned}$$

since $\dot{m} = \rho \dot{V} = \dot{V}/v$ and there is no change in kinetic and potential energies of the fluid. Then the pump efficiency becomes

$$\eta_{\text{pump}} = \frac{\Delta \dot{E}_{\text{mech,fluid}}}{\dot{W}_{\text{pump,shaft}}} = \frac{10 \text{ kW}}{13.5 \text{ kW}} = 0.741 \text{ or } \mathbf{74.1\%}$$

Discussion The overall efficiency of this pump/motor unit is the product of the mechanical and motor efficiencies, which is $0.9 \times 0.741 = 0.667$.

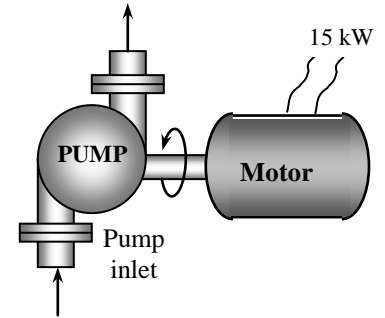

Fundamentals of Engineering (FE) Exam Problems

2-125 In a hot summer day, the air in a well-sealed room is circulated by a 0.50-hp (shaft) fan driven by a 65% efficient motor. (Note that the motor delivers 0.50 hp of net shaft power to the fan). The rate of energy supply from the fan-motor assembly to the room is

- (a) 0.769 kJ/s (b) 0.325 kJ/s (c) 0.574 kJ/s (d) 0.373 kJ/s (e) 0.242 kJ/s

Answer (c) 0.574 kJ/s

Solution Solved by EES Software. Solutions can be verified by copying-and-pasting the following lines on a blank EES screen. (Similar problems and their solutions can be obtained easily by modifying numerical values).

Eff=0.65

W_fan=0.50*0.7457 "kW"

E=W_fan/Eff "kJ/s"

"Some Wrong Solutions with Common Mistakes:"

W1_E=W_fan*Eff "Multiplying by efficiency"

W2_E=W_fan "Ignoring efficiency"

W3_E=W_fan/Eff/0.7457 "Using hp instead of kW"

2-126 A fan is to accelerate quiescent air to a velocity to 12 m/s at a rate of 3 m³/min. If the density of air is 1.15 kg/m³, the minimum power that must be supplied to the fan is

- (a) 248 W (b) 72 W (c) 497 W (d) 216 W (e) 162 W

Answer (a) 248 W

Solution Solved by EES Software. Solutions can be verified by copying-and-pasting the following lines on a blank EES screen. (Similar problems and their solutions can be obtained easily by modifying numerical values).

rho=1.15

V=12

Vdot=3 "m3/s"

mdot=rho*Vdot "kg/s"

We=mdot*V^2/2

"Some Wrong Solutions with Common Mistakes:"

W1_We=Vdot*V^2/2 "Using volume flow rate"

W2_We=mdot*V^2 "forgetting the 2"

W3_We=V^2/2 "not using mass flow rate"

2-127 A 2-kW electric resistance heater in a room is turned on and kept on for 50 min. The amount of energy transferred to the room by the heater is

- (a) 2 kJ (b) 100 kJ (c) 3000 kJ (d) 6000 kJ (e) 12,000 kJ

Answer (d) 6000 kJ

Solution Solved by EES Software. Solutions can be verified by copying-and-pasting the following lines on a blank EES screen. (Similar problems and their solutions can be obtained easily by modifying numerical values).

```
We= 2 "kJ/s"
time=50*60 "s"
We_total=We*time "kJ"
"Some Wrong Solutions with Common Mistakes:"
W1_Etotal=We*time/60 "using minutes instead of s"
W2_Etotal=We "ignoring time"
```

2-128 A 900-kg car cruising at a constant speed of 60 km/h is to accelerate to 100 km/h in 4 s. The additional power needed to achieve this acceleration is

- (a) 56 kW (b) 222 kW (c) 2.5 kW (d) 62 kW (e) 90 kW

Answer (a) 56 kW

Solution Solved by EES Software. Solutions can be verified by copying-and-pasting the following lines on a blank EES screen. (Similar problems and their solutions can be obtained easily by modifying numerical values).

```
m=900 "kg"
V1=60 "km/h"
V2=100 "km/h"
Dt=4 "s"
Wa=m*((V2/3.6)^2-(V1/3.6)^2)/2000/Dt "kW"
"Some Wrong Solutions with Common Mistakes:"
W1_Wa=((V2/3.6)^2-(V1/3.6)^2)/2/Dt "Not using mass"
W2_Wa=m*((V2)^2-(V1)^2)/2000/Dt "Not using conversion factor"
W3_Wa=m*((V2/3.6)^2-(V1/3.6)^2)/2000 "Not using time interval"
W4_Wa=m*((V2/3.6)-(V1/3.6))/1000/Dt "Using velocities"
```

2-129 The elevator of a large building is to raise a net mass of 400 kg at a constant speed of 12 m/s using an electric motor. Minimum power rating of the motor should be

- (a) 0 kW (b) 4.8 kW (c) 47 kW (d) 12 kW (e) 36 kW

Answer (c) 47 kW

Solution Solved by EES Software. Solutions can be verified by copying-and-pasting the following lines on a blank EES screen. (Similar problems and their solutions can be obtained easily by modifying numerical values).

```
m=400 "kg"
V=12 "m/s"
g=9.81 "m/s^2"
Wg=m*g*V/1000 "kW"
"Some Wrong Solutions with Common Mistakes:"
W1_Wg=m*V "Not using g"
W2_Wg=m*g*V^2/2000 "Using kinetic energy"
W3_Wg=m*g/V "Using wrong relation"
```

2-130 Electric power is to be generated in a hydroelectric power plant that receives water at a rate of 70 m³/s from an elevation of 65 m using a turbine–generator with an efficiency of 85 percent. When frictional losses in piping are disregarded, the electric power output of this plant is

- (a) 3.9 MW (b) 38 MW (c) 45 MW (d) 53 MW (e) 65 MW

Answer (b) 38 MW

Solution Solved by EES Software. Solutions can be verified by copying-and-pasting the following lines on a blank EES screen. (Similar problems and their solutions can be obtained easily by modifying numerical values).

```
Vdot=70 "m3/s"
z=65 "m"
g=9.81 "m/s^2"
Eff=0.85
rho=1000 "kg/m3"
We=rho*Vdot*g*z*Eff/10^6 "MW"
"Some Wrong Solutions with Common Mistakes:"
W1_We=rho*Vdot*z*Eff/10^6 "Not using g"
W2_We=rho*Vdot*g*z/Eff/10^6 "Dividing by efficiency"
W3_We=rho*Vdot*g*z/10^6 "Not using efficiency"
```

2-131 Consider a refrigerator that consumes 320 W of electric power when it is running. If the refrigerator runs only one quarter of the time and the unit cost of electricity is \$0.09/kWh, the electricity cost of this refrigerator per month (30 days) is

- (a) \$3.56 (b) \$5.18 (c) \$8.54 (d) \$9.28 (e) \$20.74

Answer (b) \$5.18

Solution Solved by EES Software. Solutions can be verified by copying-and-pasting the following lines on a blank EES screen. (Similar problems and their solutions can be obtained easily by modifying numerical values).

```
We=0.320 "kW"
Hours=0.25*(24*30) "h/year"
price=0.09 "$/kWh"
Cost=We*hours*price
"Some Wrong Solutions with Common Mistakes:"
W1_cost= We*24*30*price "running continuously"
```

2-132 A 2-kW pump is used to pump kerosene ($\rho = 0.820$ kg/L) from a tank on the ground to a tank at a higher elevation. Both tanks are open to the atmosphere, and the elevation difference between the free surfaces of the tanks is 30 m. The maximum volume flow rate of kerosene is

- (a) 8.3 L/s (b) 7.2 L/s (c) 6.8 L/s (d) 12.1 L/s (e) 17.8 L/s

Answer (a) 8.3 L/s

Solution Solved by EES Software. Solutions can be verified by copying-and-pasting the following lines on a blank EES screen. (Similar problems and their solutions can be obtained easily by modifying numerical values).

```
W=2 "kW"
rho=0.820 "kg/L"
z=30 "m"
g=9.81 "m/s2"
W=rho*Vdot*g*z/1000
"Some Wrong Solutions with Common Mistakes:"
W=W1_Vdot*g*z/1000 "Not using density"
```

2-133 A glycerin pump is powered by a 5-kW electric motor. The pressure differential between the outlet and the inlet of the pump at full load is measured to be 211 kPa. If the flow rate through the pump is 18 L/s and the changes in elevation and the flow velocity across the pump are negligible, the overall efficiency of the pump is

- (a) 69% (b) 72% (c) 76% (d) 79% (e) 82%

Answer (c) 76%

Solution Solved by EES Software. Solutions can be verified by copying-and-pasting the following lines on a blank EES screen. (Similar problems and their solutions can be obtained easily by modifying numerical values).

```
We=5 "kW"
Vdot= 0.018 "m3/s"
DP=211 "kPa"
Emech=Vdot*DP
Emech=Eff*We
```

2-134 A 75 hp (shaft) compressor in a facility that operates at full load for 2500 hours a year is powered by an electric motor that has an efficiency of 93 percent. If the unit cost of electricity is \$0.06/kWh, the annual electricity cost of this compressor is

- (a) \$7802 (b) \$9021 (c) \$12,100 (d) \$8389 (e) \$10,460

Answer (b) \$9021

Solution Solved by EES Software. Solutions can be verified by copying-and-pasting the following lines on a blank EES screen. (Similar problems and their solutions can be obtained easily by modifying numerical values).

```
Wcomp=75 "hp"
Hours=2500 "h/year"
Eff=0.93
price=0.06 "$/kWh"
We=Wcomp*0.7457*Hours/Eff
Cost=We*price
"Some Wrong Solutions with Common Mistakes:"
W1_cost= Wcomp*0.7457*Hours*price*Eff "multiplying by efficiency"
W2_cost= Wcomp*Hours*price/Eff "not using conversion"
W3_cost= Wcomp*Hours*price*Eff "multiplying by efficiency and not using conversion"
W4_cost= Wcomp*0.7457*Hours*price "Not using efficiency"
```

The following problems are based on the optional special topic of heat transfer

2-135 A 10-cm high and 20-cm wide circuit board houses on its surface 100 closely spaced chips, each generating heat at a rate of 0.08 W and transferring it by convection to the surrounding air at 25°C. Heat transfer from the back surface of the board is negligible. If the convection heat transfer coefficient on the surface of the board is 10 W/m²·°C and radiation heat transfer is negligible, the average surface temperature of the chips is

- (a) 26°C (b) 45°C (c) 15°C (d) 80°C (e) 65°C

Answer (e) 65°C

Solution Solved by EES Software. Solutions can be verified by copying-and-pasting the following lines on a blank EES screen. (Similar problems and their solutions can be obtained easily by modifying numerical values).

$$A=0.10*0.20 \text{ "m}^2\text{"}$$

$$Q= 100*0.08 \text{ "W"}$$

$$T_{air}=25 \text{ "C"}$$

$$h=10 \text{ "W/m}^2\text{.C"}$$

$$Q= h*A*(T_s-T_{air}) \text{ "W"}$$

"Some Wrong Solutions with Common Mistakes:"

$$Q= h*(W1_T_s-T_{air}) \text{ "Not using area"}$$

$$Q= h*2*A*(W2_T_s-T_{air}) \text{ "Using both sides of surfaces"}$$

$$Q= h*A*(W3_T_s+T_{air}) \text{ "Adding temperatures instead of subtracting"}$$

$$Q/100= h*A*(W4_T_s-T_{air}) \text{ "Considering 1 chip only"}$$

2-136 A 50-cm-long, 0.2-cm-diameter electric resistance wire submerged in water is used to determine the boiling heat transfer coefficient in water at 1 atm experimentally. The surface temperature of the wire is measured to be 130°C when a wattmeter indicates the electric power consumption to be 4.1 kW. Then the heat transfer coefficient is

- (a) 43,500 W/m²·°C (b) 137 W/m²·°C (c) 68,330 W/m²·°C (d) 10,038 W/m²·°C
(e) 37,540 W/m²·°C

Answer (a) 43,500 W/m²·°C

Solution Solved by EES Software. Solutions can be verified by copying-and-pasting the following lines on a blank EES screen. (Similar problems and their solutions can be obtained easily by modifying numerical values).

$$L=0.5 \text{ "m"}$$

$$D=0.002 \text{ "m"}$$

$$A=\pi*D*L \text{ "m}^2\text{"}$$

$$W_e=4.1 \text{ "kW"}$$

$$T_s=130 \text{ "C"}$$

$$T_f=100 \text{ "C (Boiling temperature of water at 1 atm)"}$$

$$W_e= h*A*(T_s-T_f) \text{ "W"}$$

"Some Wrong Solutions with Common Mistakes:"

$$W_e= W1_h*(T_s-T_f) \text{ "Not using area"}$$

$$W_e= W2_h*(L*\pi*D^2/4)*(T_s-T_f) \text{ "Using volume instead of area"}$$

$$W_e= W3_h*A*T_s \text{ "Using } T_s \text{ instead of temp difference"}$$

2-137 A 3-m² hot black surface at 80°C is losing heat to the surrounding air at 25°C by convection with a convection heat transfer coefficient of 12 W/m²·°C, and by radiation to the surrounding surfaces at 15°C. The total rate of heat loss from the surface is

- (a) 1987 W (b) 2239 W (c) 2348 W (d) 3451 W (e) 3811 W

Answer (d) 3451 W

Solution Solved by EES Software. Solutions can be verified by copying-and-pasting the following lines on a blank EES screen. (Similar problems and their solutions can be obtained easily by modifying numerical values).

```
sigma=5.67E-8 "W/m^2.K^4"
eps=1
A=3 "m^2"
h_conv=12 "W/m^2.C"
Ts=80 "C"
Tf=25 "C"
Tsurr=15 "C"
Q_conv=h_conv*A*(Ts-Tf) "W"
Q_rad=eps*sigma*A*((Ts+273)^4-(Tsurr+273)^4) "W"
Q_total=Q_conv+Q_rad "W"
"Some Wrong Solutions with Common Mistakes:"
W1_Ql=Q_conv "Ignoring radiation"
W2_Q=Q_rad "ignoring convection"
W3_Q=Q_conv+eps*sigma*A*(Ts^4-Tsurr^4) "Using C in radiation calculations"
W4_Q=Q_total/A "not using area"
```

2-138 Heat is transferred steadily through a 0.2-m thick 8 m by 4 m wall at a rate of 2.4 kW. The inner and outer surface temperatures of the wall are measured to be 15°C to 5°C. The average thermal conductivity of the wall is

- (a) 0.002 W/m·°C (b) 0.75 W/m·°C (c) 1.0 W/m·°C (d) 1.5 W/m·°C (e) 3.0 W/m·°C

Answer (d) 1.5 W/m·°C

Solution Solved by EES Software. Solutions can be verified by copying-and-pasting the following lines on a blank EES screen. (Similar problems and their solutions can be obtained easily by modifying numerical values).

```
A=8*4 "m^2"
L=0.2 "m"
T1=15 "C"
T2=5 "C"
Q=2400 "W"
Q=k*A*(T1-T2)/L "W"
"Some Wrong Solutions with Common Mistakes:"
Q=W1_k*(T1-T2)/L "Not using area"
Q=W2_k*2*A*(T1-T2)/L "Using areas of both surfaces"
Q=W3_k*A*(T1+T2)/L "Adding temperatures instead of subtracting"
Q=W4_k*A*L*(T1-T2) "Multiplying by thickness instead of dividing by it"
```

2-139 The roof of an electrically heated house is 7 m long, 10 m wide, and 0.25 m thick. It is made of a flat layer of concrete whose thermal conductivity is 0.92 W/m.°C. During a certain winter night, the temperatures of the inner and outer surfaces of the roof are measured to be 15°C and 4°C, respectively. The average rate of heat loss through the roof that night was

- (a) 41 W (b) 177 W (c) 4894 W (d) 5567 W (e) 2834 W

Answer (e) 2834 W

Solution Solved by EES Software. Solutions can be verified by copying-and-pasting the following lines on a blank EES screen. (Similar problems and their solutions can be obtained easily by modifying numerical values).

$A=7*10$ "m^2"

$L=0.25$ "m"

$k=0.92$ "W/m.C"

$T1=15$ "C"

$T2=4$ "C"

$Q_cond=k*A*(T1-T2)/L$ "W"

"Some Wrong Solutions with Common Mistakes:"

$W1_Q=k*(T1-T2)/L$ "Not using area"

$W2_Q=k*2*A*(T1-T2)/L$ "Using areas of both surfaces"

$W3_Q=k*A*(T1+T2)/L$ "Adding temperatures instead of subtracting"

$W4_Q=k*A*L*(T1-T2)$ "Multiplying by thickness instead of dividing by it"

2-140 ... 2-147 Design and Essay Problems

